

LCD Module Technical Specification

First Edition
 Oct 24, 2003
 Final Revision

Type No. **T-51750GD065J-FW-AB**

I. Sato

Approved by (Quality Assurance Division)

H. Gondra

Checked by (ACI Engineering Division)

R. Wagnon

Prepared by (Module Coordination Group)

Table of Contents

1. Overview.....	2
2. Absolute Maximum Ratings.....	3
3. Electrical Characteristics.....	3
4. Interface Pin Connection.....	6
5. Interface Timing.....	7
6. Block Diagram.....	10
7. Optical Characteristics.....	11
8. Inverted Scan Capability.....	13
9. Mechanical Specifications.....	14
10. Reliability Test Condition.....	16
11. Inspection Standards.....	17
12. Code System of Production Lot.....	18
13. Type Number.....	18
14. Applying Precautions.....	18
15. Precautions Relating Product Handling.....	19
16. Warranty.....	20

Revision History

Rev.	Date	Page	Comment

1. Overview

T-51750GD065J-FW-AB is 6.5" color TFT-LCD (Thin Film Transistor Liquid Crystal Display) module composed of LCD panel, driver ICs, control circuit, and backlight unit.

By applying 6 bit digital data, 640 × 480, 260 K-color images are displayed on the 6.5" diagonal screen. Input power voltage is 3.3 V or 5V for LCD driving.

Inverter for backlight is not included in this module. General specifications are summarized in the following table:

ITEM	SPECIFICATION
Display Area (mm)	132.5 (H) × 99.4 (V) (6.5-inch diagonal)
Number of Dots	640 × 3 (H) × 480 (V)
Pixel Pitch (mm)	0.207 (H) × 0.207 (V)
Color Pixel Arrangement	RGB vertical stripe
Display Mode	Normally white
Number of Color	6bit, 262,144 colors
Contrast ratio	300
Optimum Viewing Angle(Contrast ratio)	6 o'clock
Brightness (cd/m ²)	400
Module Size (mm)	158.0 (W) × 120.36 (H) × 11.55 (D)
Module Mass (g)	190(Typ)
Backlight Unit	CCFL, 2-tubes, replaceable
Surface Treatment	Anti-reflection and hard-coating (over 2H)
Attached Drawing	Dimensional Outline UE-311848

Characteristic value without any note is typical value.

The LCD product described in this specification is designed and manufactured for the standard use in OA equipment and consumer products, such as computers, communication equipment, industrial robots, AV equipment and so on.

Do not use the LCD product for the equipment that require the extreme high level of reliability, such as aerospace applications, submarine cables, nuclear power control systems and medical or other equipment for life support.

OPTREX assumes no responsibility for any damage resulting from the use of the LCD product in disregard of the conditions and handling precautions in this specification.

If customers intend to use the LCD product for the above items or other no standard items, please contact our sales persons in advance.

2. Absolute Maximum Ratings

ITEM	SYMBOL	MIN.	MAX.	UNIT
Power Supply Voltage for LCD	VCC	0	5.5	V
Logic Input Voltage	VI	0	7	V
Lamp Current	IL	0	7.0	mArms
Lamp Frequency	FL	40	80	kHz
Operation Temperature *1)	T _{op}	0	60	°C
Storage Temperature *1)	T _{stg}	-25	70	°C

[Note]

*1) Top, Tstg ≤ 40°C: 90%RH max. without condensation

Top, Tstg > 40°C: Absolute humidity shall be less than the value of 90%RH at 40°C without condensation.

3. Electrical Characteristics

(1) TFT- LCD

Ambient Temperature : Ta = 25°C

ITEM	SYMBOL	MIN.	TYP.	MAX.	UNIT	Remarks
Power Supply Voltages for LCD Note A)	VCC	3.0	3.3	3.6	V	for 3.3V system
		4.5	5.0	5.5	V	for 5V system
Power Supply Currents for LCD Note B)	ICC	--	240	--	mA	for 3.3V system
		--	180	--	mA	for 5V system
Permissive input ripple Voltage	VRP	--	--	100	mVp-p	VCC=+3.3V
		--	--	100	mVp-p	VCC=+5.0V
Logic Input Voltage	High	VIH	2.4	--	V	VCC=MAX
	Low	VIL	0	--	V	VCC=MIN

(2) Backlight

Ta=25°C

ITEM	SYMBOL	MIN.	TYP.	MAX.	UNIT	Remarks
Lamp Voltage	VL	--	320	--	Vrms	IL=6.0mArms
Lamp Current	IL	--	6.0 <small>Note C)</small>	--	mArms	*1)
Lamp Frequency	FL	40	--	80	kHz	*2)
Starting Lamp Voltage	VS	--	--	520	Vrms	
Lamp Life Time	LT	30000	--	--	h	*3), IL=6.0mArms, Continuous Operation

*1) Lamp Current measurement method (The current meter is inserted in low voltage line.)

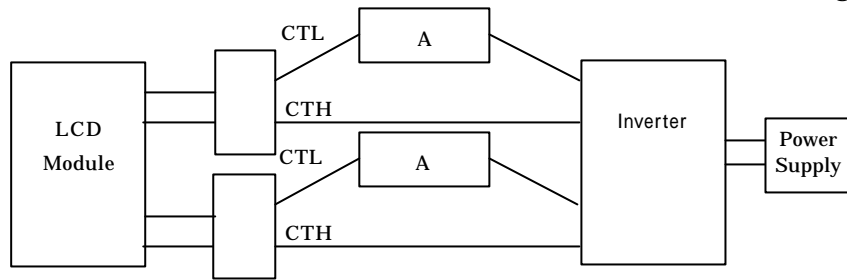

*2) Lamp frequency of inverter may produce interference with horizontal synchronous frequency, and this may cause horizontal beat on the display. Therefore, please adjust lamp frequency, and keep inverter as far from module as possible or use electronic shielding between inverter and module to avoid the interference.

*3) Lamp life time is defined as the time either when the brightness becomes 50% of the initial value, or when the starting lamp voltage does not meet the value specified in this table.

[Note]

A) Power and signals sequence:

- $t1 \leq 10 \text{ ms}$ $200 \text{ ms} < t6$
- $0 < t2 \leq 50 \text{ ms}$ $0 \leq t7$
- $0 < t3 \leq 50 \text{ ms}$
- $0 < t4 \leq 50 \text{ ms}$
- $500 \text{ ms} < t5$

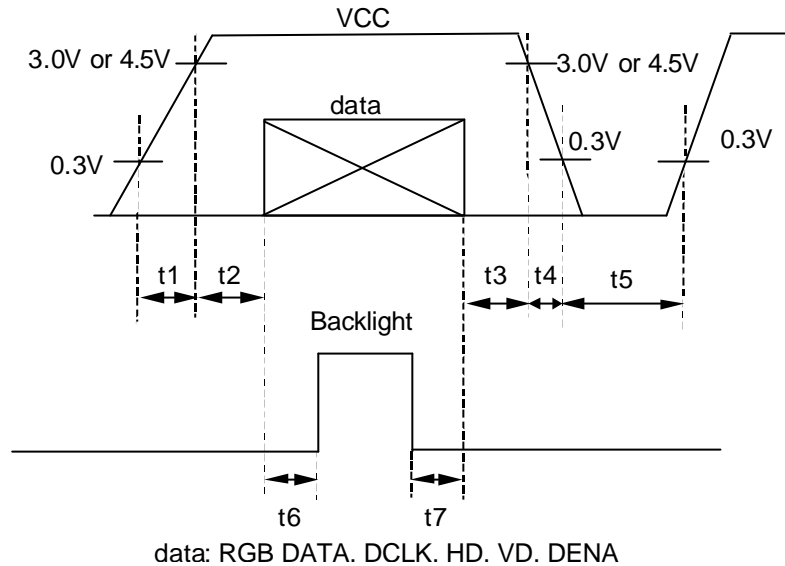

VCC-dip conditions:

- 1) When $2.4 \text{ V} \leq VCC < 3.0 \text{ V}$, $t_d \leq 10 \text{ ms}$
- 2) When $VCC < 2.4 \text{ V}$

VCC-dip conditions should also follow the power and signals sequence.

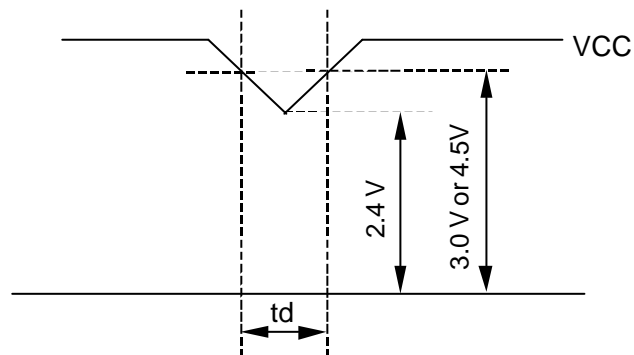

B) Typical current condition:

64- gray- bar-pattern
480 line mode

$VCC = +3.3 \text{ V}$, $f_H=31.5\text{kHz}$, $f_V=60\text{Hz}$, $f_{CLK}= 25\text{MHz}$

$VCC = +5.0 \text{ V}$, $f_H=31.5\text{kHz}$, $f_V=60\text{Hz}$, $f_{CLK}= 25\text{MHz}$

C) For typical luminance of 400 cd/m^2

4. Interface Pin Connection

CN 1 (INTERFACE SIGNAL)

Used connector: DF9B-31P-1V (Hirose)

Corresponding connector: DF9B-31S-1V (Hirose)

Pin No.	Symbol	Function
1	GND	
2	DCLK	Clock signal for sampling catch data signal
3	HD	Horizontal sync signal
4	VD	Vertical sync signal
5	GND	
6	R0	Red data signal(LSB)
7	R1	Red data signal
8	R2	Red data signal
9	R3	Red data signal
10	R4	Red data signal
11	R5	Red data signal(MSB)
12	GND	
13	G0	Green data signal(LSB)
14	G1	Green data signal
15	G2	Green data signal
16	G3	Green data signal
17	G4	Green data signal
18	G5	Green data signal(MSB)
19	GND	
20	B0	Blue data signal(LSB)
21	B1	Blue data signal
22	B2	Blue data signal
23	B3	Blue data signal
24	B4	Blue data signal
25	B5	Blue data signal(MSB)
26	GND	
27	DENA	Data enable signal(to settle the viewing area)
28	VCC	Power Supply (DC 3.3V or 5V)
29	VCC	Power Supply (DC 3.3V or 5V)
30	TEST	This pin should be open. Test signal output for only internal test use.
31	REV	Reverse scan control. L = Normal, H = Reverse

*) The shielding case is connected with GND

CN 2, CN 3 (BACKLIGHT)

Backlight-side connector: BHR-02(8.0)VS-1N(JST)

Inverter-side connector: SM02(8.0)B-BHS(JST)

Pin No.	Symbol	Function
1	CTH	VBLH (High Voltage)
3	CTL	VBLL (Low Voltage)

[Note] VBLH-VBLL = VL

5. Interface Timing

(1) Timing Specifications

ITEM		SYMBOL	MIN.	TYP.	MAX.	UNIT
DCLK	Frequency	f_{CLK}	20	25	30	MHz
	Period	t_{CLK}	33.3	40	50	ns
	Low Width	t_{WCL}	10	--	--	ns
	High Width	t_{WCH}	10	--	--	ns
DATA (R,G,B,DENA, HD, VD)	Set up time	t_{DS}	5	--	--	ns
	Hold time	t_{DH}	5	--	--	ns
DENA	Horizontal Active Time	t_{HA}	640	640	640	t_{CLK}
	Horizontal Front Porch	t_{HFP}	0	--	--	t_{CLK}
	Horizontal Back Porch	t_{HBP}	7	--	--	t_{CLK}
	Vertical Active Time	t_{VA}	480	480	480	t_H
	Vertical Front Porch	t_{VFP}	1	20	--	t_H
	Vertical Back Porch	t_{VBP}	8	20	--	t_H
HD	Frequency	f_H	27	31.5	38	kHz
	Period	t_H	26.3	31.7	37.0	μs
	Low Width	t_{WHL}	5	--	--	t_{CLK}
VD	Frequency	f_V	55	60	70	Hz
	Period	t_V	14.3	16.7	18.2	ms
	Low Width	t_{WVL}	3	--	--	t_H

[Note]

- 1) DATA is latched at fall edge of DCLK in this timing specification.
- 2) Polarities of HD and VD are negative in this specification.
- 3) DENA (Data Enable) should always be positive polarity as shown in the timing specification.
- 4) DCLK should appear during all invalid period, and HD should appear during invalid period of frame cycle.
- 5) Accepted only 640 data and 480 lines.
- 6) Both HREV and VREV should be stable during operation.

(2) Timing Chart

a. Pixel Timing Chart

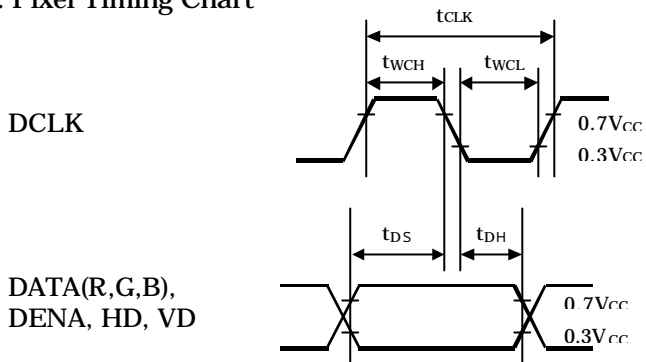

b. Horizontal Timing Chart

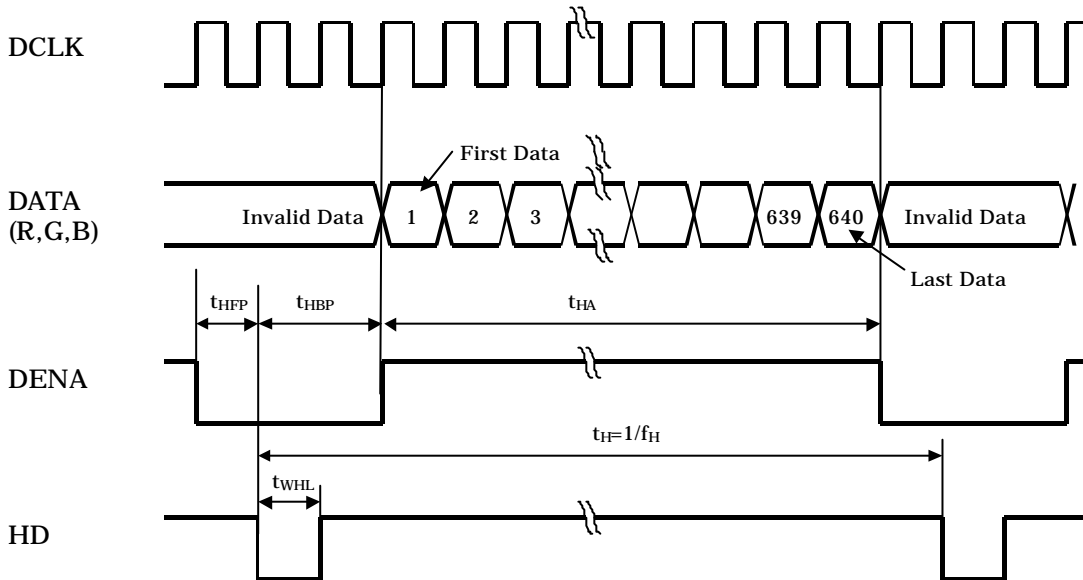

(3) Color Data Assignment

c. Vertical Timing Chart

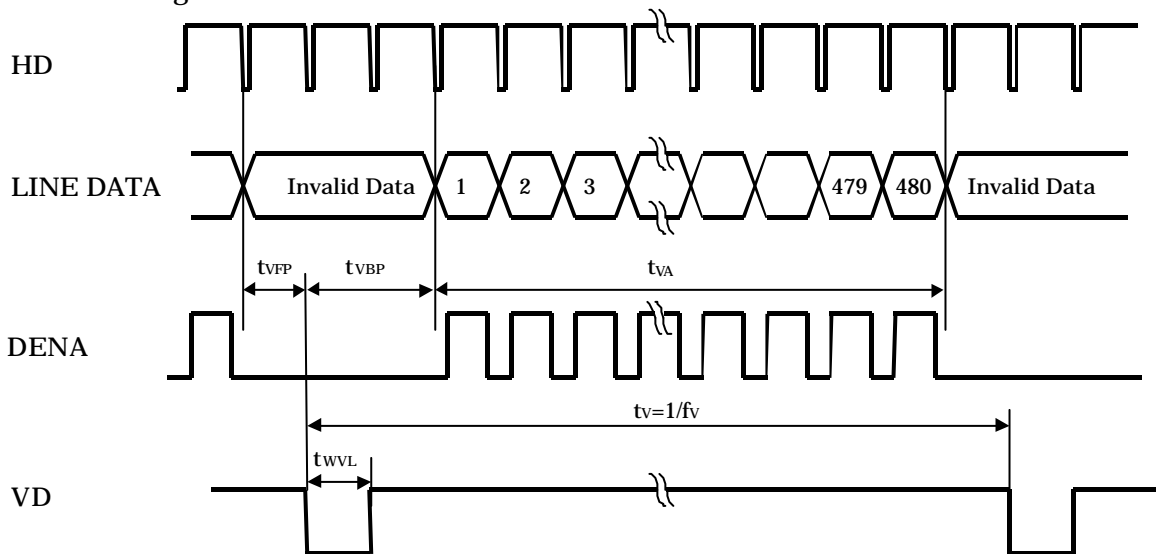

COLOR	INPUT DATA	R DATA						G DATA						B DATA					
		R5	R4	R3	R2	R1	R0	G5	G4	G3	G2	G1	G0	B5	B4	B3	B2	B1	B0
		MS B					LSB	MS B					LSB	MS B					LSB
BASIC COLOR	BLACK	0	0	0	0	0	0	0	0	0	0	0	0	0	0	0	0	0	0
	RED(63)	1	1	1	1	1	1	0	0	0	0	0	0	0	0	0	0	0	0
	GREEN(63)	0	0	0	0	0	0	1	1	1	1	1	1	0	0	0	0	0	0
	BLUE(63)	0	0	0	0	0	0	0	0	0	0	0	0	1	1	1	1	1	1
	CYAN	0	0	0	0	0	0	1	1	1	1	1	1	1	1	1	1	1	1
	MAGENTA	1	1	1	1	1	1	0	0	0	0	0	0	1	1	1	1	1	1
	YELLOW	1	1	1	1	1	1	1	1	1	1	1	1	0	0	0	0	0	0
	WHITE	1	1	1	1	1	1	1	1	1	1	1	1	1	1	1	1	1	1
RED	RED(0)	0	0	0	0	0	0	0	0	0	0	0	0	0	0	0	0	0	
	RED (1)	0	0	0	0	0	1	0	0	0	0	0	0	0	0	0	0	0	
	RED(2)	0	0	0	0	1	0	0	0	0	0	0	0	0	0	0	0	0	
	RED (62)	1	1	1	1	1	0	0	0	0	0	0	0	0	0	0	0	0	0
RED(63)	1	1	1	1	1	1	0	0	0	0	0	0	0	0	0	0	0	0	
GREEN	GREEN(0)	0	0	0	0	0	0	0	0	0	0	0	0	0	0	0	0	0	
	GREEN (1)	0	0	0	0	0	0	0	0	0	0	1	0	0	0	0	0	0	
	GREEN(2)	0	0	0	0	0	0	0	0	0	1	0	0	0	0	0	0	0	
	GREEN(62)	0	0	0	0	0	0	1	1	1	1	1	0	0	0	0	0	0	0
GREEN(63)	0	0	0	0	0	0	1	1	1	1	1	1	0	0	0	0	0	0	
BLUE	BLUE(0)	0	0	0	0	0	0	0	0	0	0	0	0	0	0	0	0	0	
	BLUE(1)	0	0	0	0	0	0	0	0	0	0	0	0	0	0	0	0	1	
	BLUE(2)	0	0	0	0	0	0	0	0	0	0	0	0	0	0	0	1	0	
	BLUE(62)	0	0	0	0	0	0	0	0	0	0	0	0	1	1	1	1	1	0
BLUE(63)	0	0	0	0	0	0	0	0	0	0	0	0	1	1	1	1	1	1	

[Note]

1) Definition of gray scale

Color (n) --- n indicates gray scale level.

Higher n means brighter level.

2) Data 1:High, 0: Low

6. Block Diagram

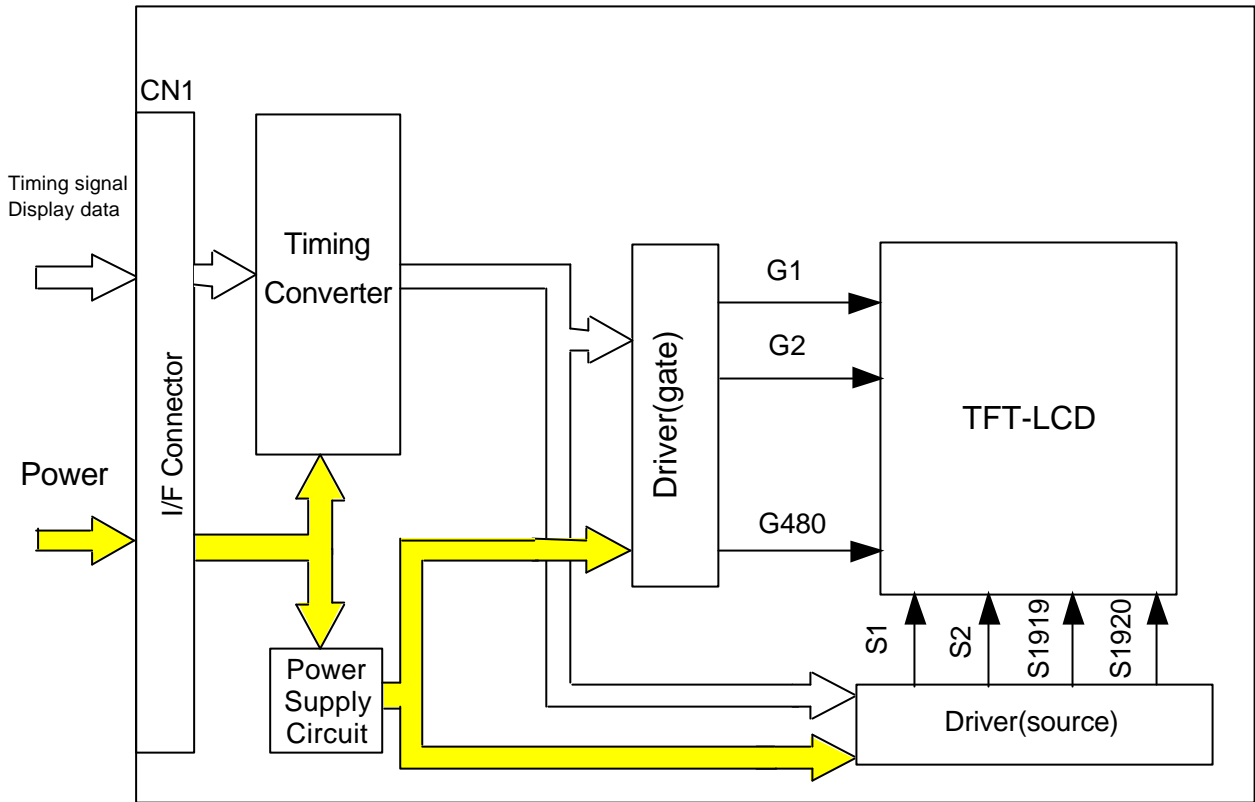

BACKLIGHT

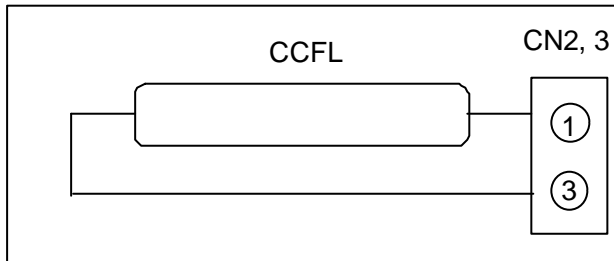

7. Optical Characteristics

Ta=25°C, VCC=3.3V, Input Signals: Typ. Values shown in Section 5

ITEM		SYMBOL	CONDITION	MIN.	TYP.	MAX.	UNIT	Remarks
Contrast Ratio		CR	Best viewing	--	300	--	--	*1)*3)
Luminance		Lw	$\theta = \phi = 0^\circ$	--	400	--	cd/m ²	*2)*3)
Response Time		tr	$\theta = \phi = 0^\circ$	--	15	--	ms	*3)*4)
		tf	$\theta = \phi = 0^\circ$	--	16	--	ms	*3)*4)
Viewing Angle	Horizontal	ϕ	CR \geq 10	--	-55~55	--	°	*3)
	Vertical	θ		--	-60~30	--	°	*3)
Image Sticking		tis	2 h	--	--	2	s	*5)
Color Coordinates	Red	Rx	$\theta = \phi = 0^\circ$	--	0.55	--	--	*3)
		Ry		--	0.34	--		
	Green	Gx		--	0.31	--		
		Gy		--	0.56	--		
	Blue	Bx		--	0.15	--		
By		--	0.17	--				
White	Wx	--	0.31	--				
	Wy	--	0.36	--				

[Note]

These items are measured using BM-5A (TOPCON) or LCD-7000 (Otsuka Electronic) under the dark room condition (no ambient light).

Condition: IL = 6.0 mArms, FL=58kHz

*1) Definition of Contrast Ratio

CR=ON (White) Luminance / OFF (Black) Luminance: average of 5 points

*2) Definition of Luminance

Lw= ON (White) Luminance: average of 5 points

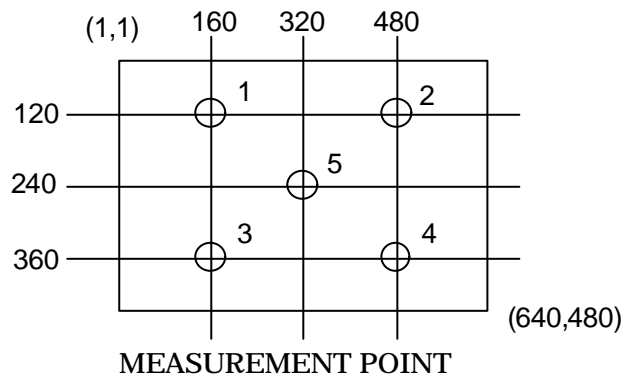

*3) Definition of Viewing Angle(θ , ϕ)

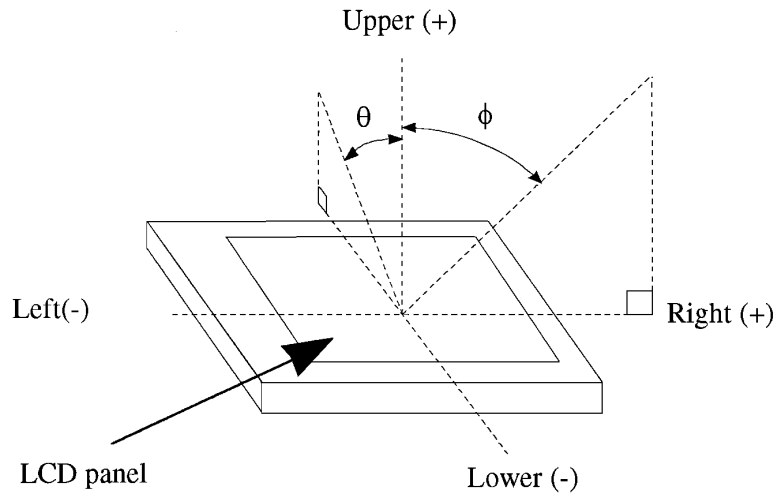

*4) Definition of Response Time

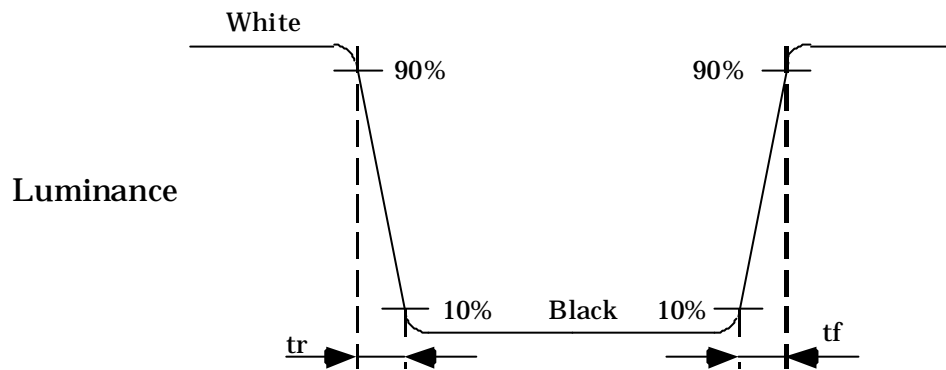

*5) Image Sticking

Continuously display the test pattern shown in the figure below for two-hours. Then display a completely white screen. The previous image shall not persist more than two seconds at 25°C.

TEST PATTERN FOR IMAGE STICKING TEST

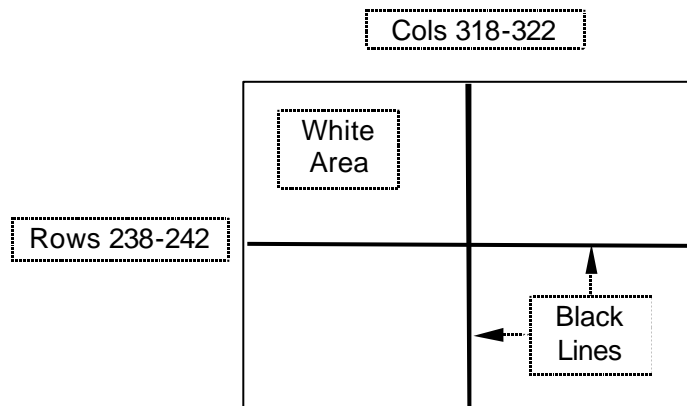

8. Inverted Scan Capability

This module has the capability of inverting scan direction by signaling from controller. Both horizontal and vertical scan direction can be selected independently. Note that scan direction cannot be changed during operation. The following figure shows the relation between the display position and the scan direction.

DISPLAY POSITION

Normal scan: REV = "L"

D(1, 1)	D(2, 1)	---	D(X, 1)	---	D(639, 1)	D(640, 1)
D(1, 2)	D(2, 2)	---	D(X, 2)	---	D(639, 2)	D(640, 2)
↓	↓	+	+	+	↓	↓
D(1, Y)	D(2, Y)	---	D(X, Y)	---	D(639, Y)	D(640, Y)
↓	↓	+	+	+	↓	↓
D(1,479)	D(2,479)	---	D(X,479)	---	D(639,479)	D(640,479)
D(1,480)	D(2,480)	---	D(X,480)	---	D(639,480)	D(640,480)

Reverse scan: REV = "H"

D(640,480)	D(639,480)	---	D(X,480)	---	D(2,480)	D(1,480)
D(640,479)	D(639,479)	---	D(X,479)	---	D(2,479)	D(1,479)
↓	↓	+	+	+	↓	↓
D(640, Y)	D(639, Y)	---	D(X, Y)	---	D(2, Y)	D(1, Y)
↓	↓	+	+	+	↓	↓
D(640, 2)	D(639, 2)	---	D(X, 2)	---	D(2, 2)	D(1, 2)
D(640, 1)	D(639, 1)	---	D(X, 1)	---	D(2, 1)	D(1, 1)

The following drawing shows the relationship between the viewing direction and the scan direction.

Normal scan

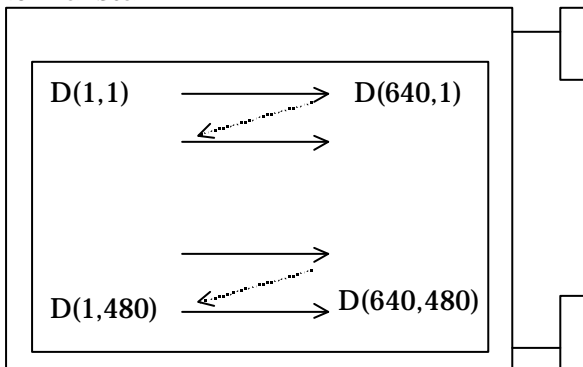

Reverse scan

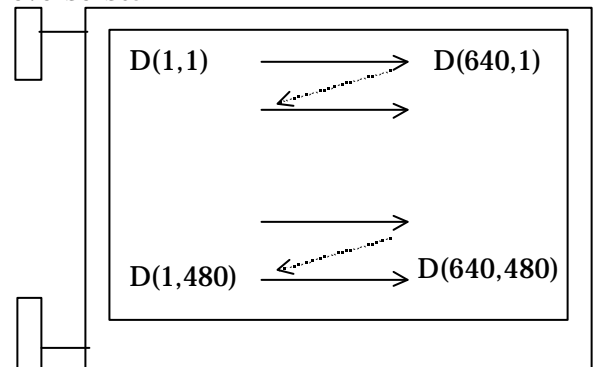

9. Mechanical Specifications

(1) Front Side

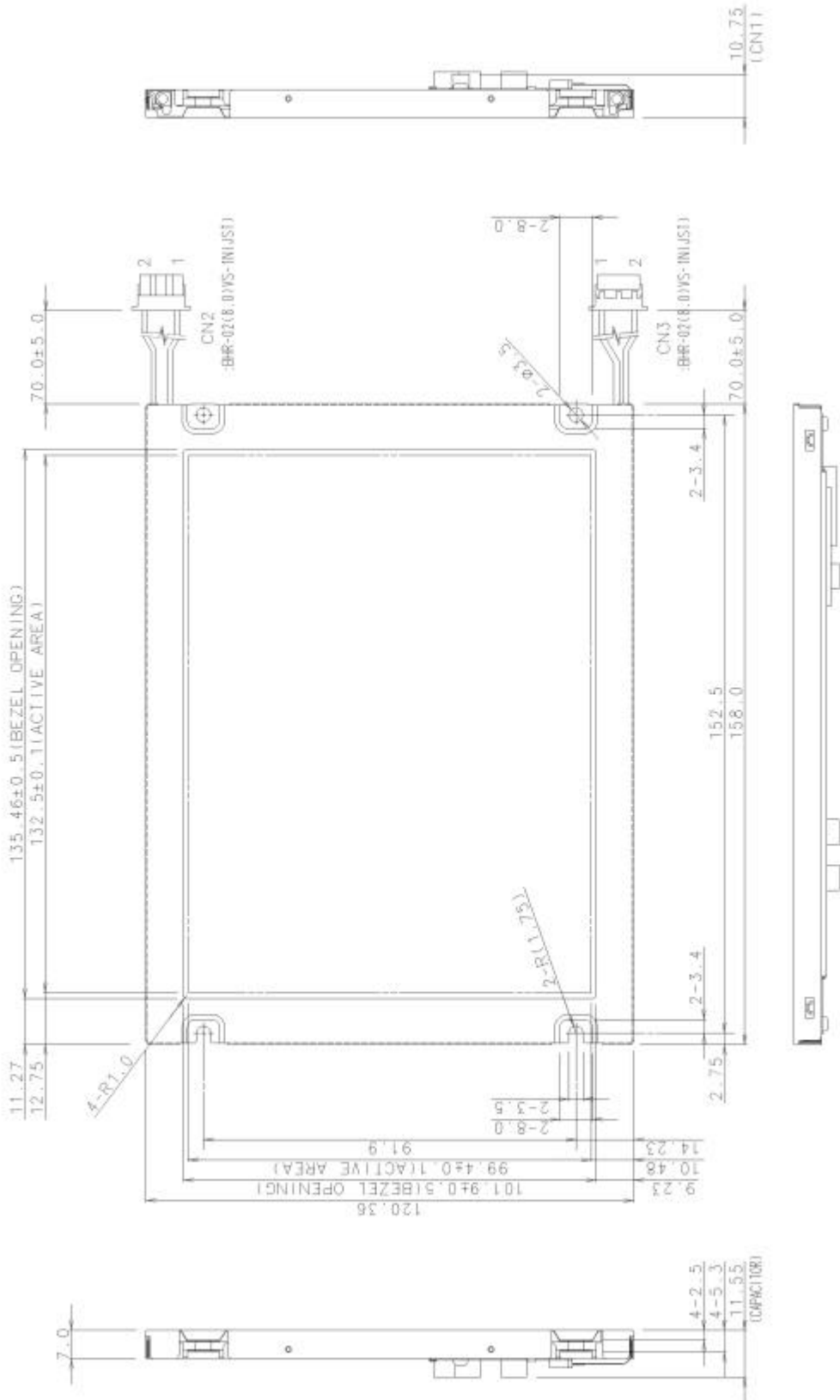

Tolerance is ±0.5mm unless noted.

(2) Rear Side

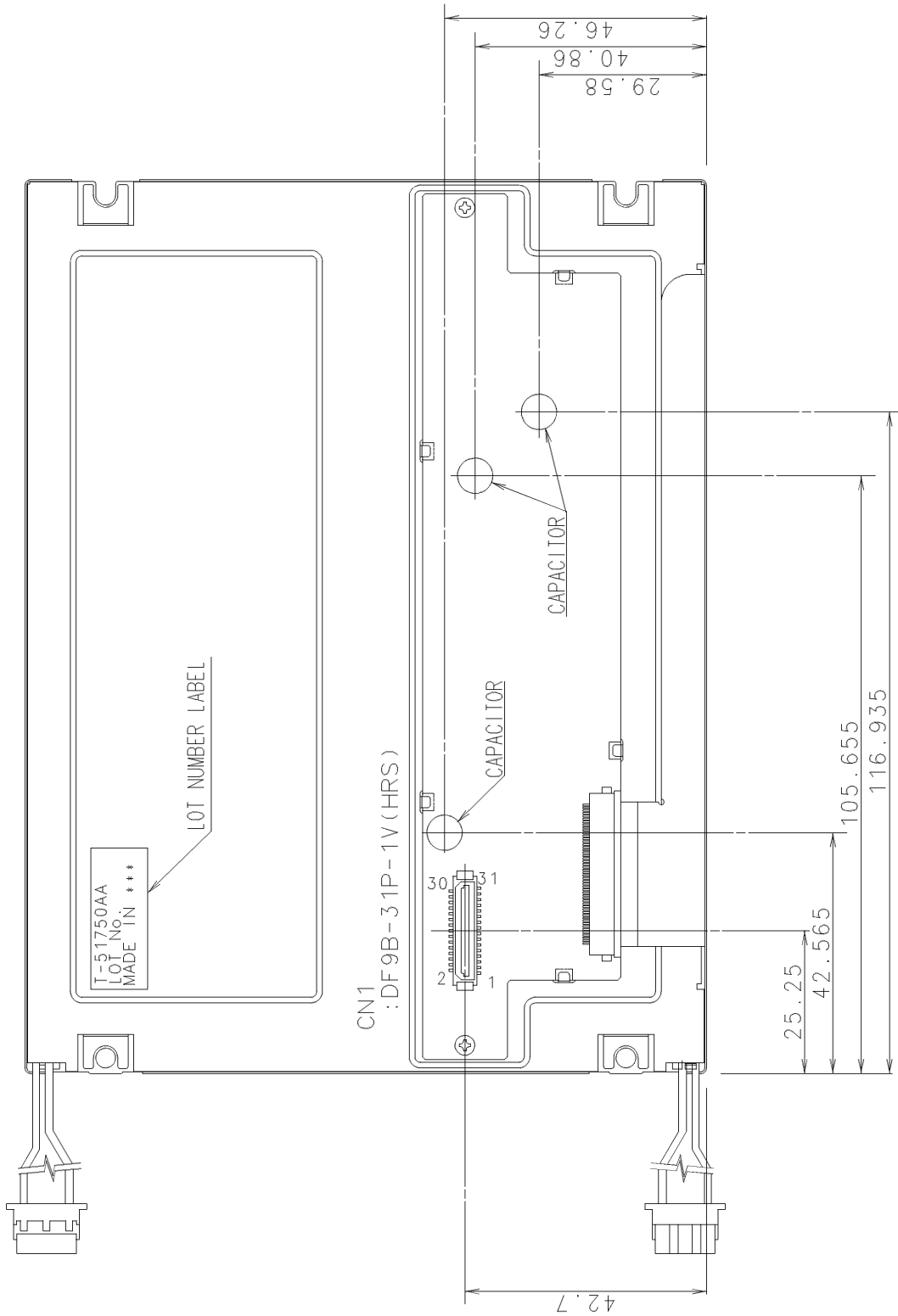

Tolerance is $\pm 0.5\text{mm}$ unless noted.

[Note]

We recommend you referring to the detailed drawing for your design.
Please contact our company sales representative when you need the detailed drawing.

T-51750GD065J-FW-AB (AB) No. 2003-0198	OPTREX CORPORATION	Page 15/20
--	--------------------	------------

10. Reliability Test Condition

(1) Temperature and Humidity

TEST ITEM	CONDITIONS
HIGH TEMPERATURE STORAGE	70°C, 96 h
LOW TEMPERATURE STORAGE	-25°C, 96h
HIGH TEMPERATURE OPERATION	60°C, 96 h
LOW TEMPERATURE OPERATION	0°C, 96h
HIGH TEMPERATURE HIGH HUMIDITY OPERATION	40°C, 90%RH, 96 h

(2) Shock & Vibration

ITEM	CONDITIONS
SHOCK (NON-OPERATION)	Shock level: 490m/s ² Waveform: half sinusoidal wave, 11ms Number of shocks: one shock input in each direction of three mutually perpendicular axis for a total of six shock inputs
VIBRATION (NON-OPERATION)	Frequency : 10- 57Hz / Vibration width(one side):0.075mm :58- 500Hz / Gravity: 9.8m/s ² Sweep time: 11minutes Test period: 3hrs for each direction of X,Y,Z

(3) Judgment standard

The judgment of the above tests should be made as follow:

Pass: Normal display image with no obvious non-uniformity and no line defect.

Partial transformation of the module parts should be ignored.

Fail: No display image, obvious non-uniformity, or line defects.