

CRYSTAL CLEAR TECHNOLOGY

Product Specification

T570B01X00

(REVISION 3)

Crystal Clear Technology sdn. bhd.

16 Jalan TP5, Taman Perindustrian Sime UEP,
47600 Subang Jaya, Selangor DE
Malaysia.

T: +603 80247099

website: www.cct.com.my



1.0 Table of Contents

No	Title	Page
1	Table of Contents	1
2	Record of revision	2
3	General Specification	3
4	Absolute Maximum Ratings	4
5	Electrical Characteristics	4
6	Reliability test condition	5
7	Interface	6
8	Optical Characteristics	7
9	LVDS Receiver DC Specifications	10
10	AC Timing Diagram	11
11	TTL Data Timing Diagram	12
12	Block Diagram	14
13	Inspection criteria	15
14	Precaution for using TFT modules	16
15	Mechanical Specification	20



2.0 Record of revision

Rev	Date	Item	Page	Comment	Originator	Checked By
1.0	05.11.15			Initial Release	SCChong	Azhar
2.0	28.01.16			Change model name T570A01N00 to T570X01X00	Azhar	Azhar
3.0	10.01.16			Change part no T570X01X00 to T570B01X00, change quality assurance to inspection criteria, add cct website at front page, change operating temperature and storage temperature, add reliability test condition, and change backlight brightness.	Adam	Azhar



3.0 General specification

Item	Contents	Unit	Note
LCD Type	5.7" TFT	-	
Display color	16M		1
Viewing Direction (Optimum View)	6	O 'Clock	
Module size	144(W) x 104.6(H) x 11.0(T)	mm	2
Active Area(W×H)	115.2 x 86.4	mm	
Number of Dots	640(RGB) × 480	dots	
Controller	HX8250x2 + HX8678	-	
Backlight	30-LEDs (white)	pcs	
Brightness	450	cd/m2	3
Interface Mode	LVDS	-	
Data Transfer	RGB	-	

Note1: Color tone is slightly changed by temperature and driving voltage.

Note2: FPC or wire are not included.

Note3: Brightness on LCD surface. Module with CTP or RTP, brightness will be about 20% (max) lower on the touch panel surface.

AVAILABLE OPTION

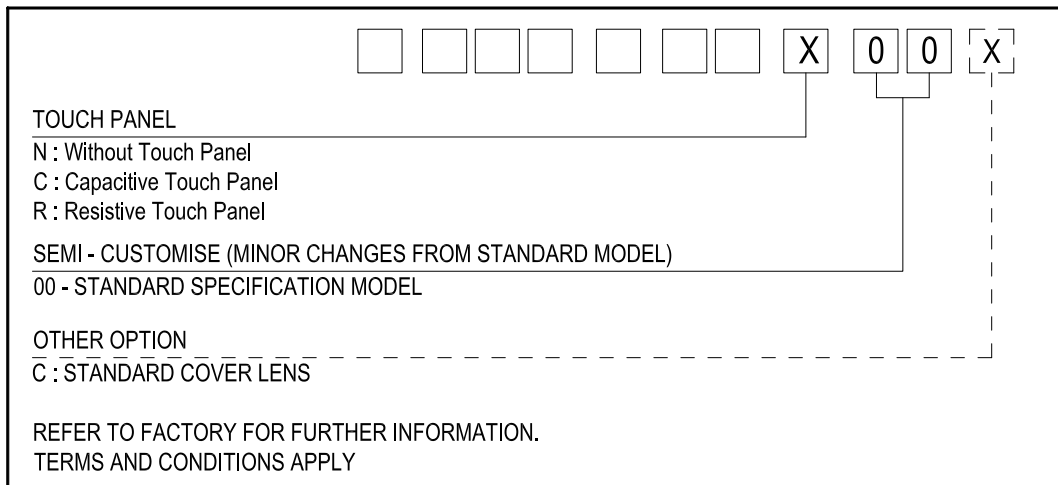

**4.0 Absolute maximum rating (at V_{ss} = 0V, ambient temperature = 25°C)**

NO	ITEM	SIMBOL	MIN	MAX	UNI T
1.	Operating Voltage Range	V _{DD}	-0.3	4.0	V
2.	Operating Temperature	T _{op}	-10°C to +60°C		°C
3.	Storage Temperature	T _{st}	-20°C to +70°C		°C

5.0 Electrical characteristics

NO	ITEM	SYMBOL	CONDITION	MIN	TYP	MAX	UNI T
1.	Operating Voltage	V _{DD}	-	-	3.3	-	V
2.	Current Supply	I _{DD}	-	-	TBD	-	uA
3.	Input Voltage (high)	V _{ih}	H level	2.0		V _{DD}	V
4.	Input Voltage (low)	V _{il}	L level	GND		0.8	V

5.1 Backlight Specification

ITEM	SYMBOL	MIN	TYP	MAX	UNIT
Brightness	B _p	-	6300	-	cd/m ²
Uniformity	ΔB _p	70	80	-	%
Forward Voltage	V _f	8.7	9.0	9.6	V

- *Note:
1. Lifetime of backlight is 40K hrs.
 2. Lifetime of backlight is defined as decay time for backlight brightness to become 50% of its original brightness.
 3. Printing colour on diffuser will be based on limit sample provided by supplier.



6.0 Reliability test condition

Item		Test Condition
Operating	High Temperature	60degC, 240 hrs
	Low Temperature	-10degC,240 hrs
Storage	High Temperature	70degC, 240hrs and recovery for 2hrs
	Low Temperature	-20degC, 240hrs and recovery for 2hrs
	High Temperature and High Humidity	50degC, 90%RH, 240hrs and recovery for 2 hrs
Thermal	Cycle	RT → 10degC → Rt → 60degC → RT 0min 30min 5min 30min 5min 50 cycles (Power off)
	Shock	RT → 10degV → 60degC 0min 30min 30min 50 cycles (Power off)

Note: RT means Room temperature

**7.0 Interface**

Display Driver		HX8250x2 + HX8678
Pin No	Symbol	Description
1	VDD	Power Supply Pin 3.3V
2	VDD	Power Supply Pin 3.3V
3	GND	Ground Pin
4	GND	Ground Pin
5	GND	Ground Pin
6	RIN0-	Negative LVDS differential data input
7	RIN0+	Positive LVDS differential data input
8	GND	Ground Pin
9	RIN1-	Negative LVDS differential data input
10	RIN1+	Positive LVDS differential data input
11	GND	Ground Pin
12	RIN2-	Negative LVDS differential data input
13	RIN2+	Positive LVDS differential data input
14	GND	Ground Pin
15	LVDS CLK-	Clock Signal (-)
16	LVDS CLK+	Clock Signal (+)
17	GND	Ground Pin
18	RIN3-	Negative LVDS differential data input
19	RIN3+	Positive LVDS differential data input
20	GND	Ground Pin



8. Optical Characteristics

Item	Symbol	Condition	Min.	Typ.	Max.	Unit	Note
Brightness	Bp	$\theta=0^\circ$ $\Phi=0^\circ$	-	450	-	Cd/m ²	1
Uniformity	ΔBp		70	80	-	%	1,2
Viewing Angle	3:00	$Cr \geq 10$	-	65	-	Deg	3
	6:00		-	55	-		
	9:00		-	65	-		
	12:00		-	45	-		
Contrast Ratio	Cr	$\theta=0^\circ$ $\Phi=0^\circ$	350	400	-	-	4
Response Time	T _r		-	16	-	ms	5
	T _f		-	12	-	ms	
NTSC Ratio	S	45	60	-	%		

Note: The parameter is slightly changed by temperature, driving voltage and materiel

Note 1: The data are measured after LEDs are turned on for 5 minutes. LCM displays full white. The brightness is the average value of 9 measured spots. Measurement equipment PR-705 ($\Phi 8\text{mm}$)

Measuring condition:

- Measuring surroundings: Dark room.

- Measuring temperature: Ta=25°C.

- Adjust operating voltage to get optimum contrast at the centre of the display.

Measured value at the centre point of LCD panel after more than 5 minutes while backlight turning on.

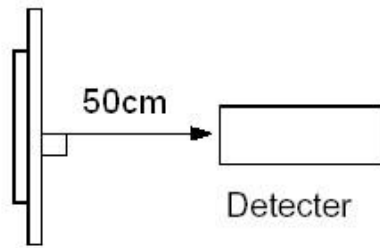

Note 2: The luminance uniformity is calculated by using following formula.

$$\Delta Bp = Bp (\text{Min.}) / Bp (\text{Max.}) \times 100 (\%)$$

$Bp (\text{Max.})$ = Maximum brightness in 9 measured spots
 $Bp (\text{Min.})$ = Minimum brightness in 9 measured spots.

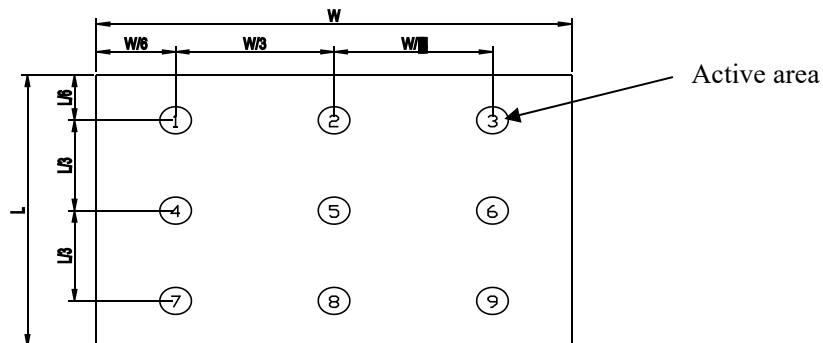

Note 3: The definition of viewing angle:

Refer to the graph below marked by θ and ϕ

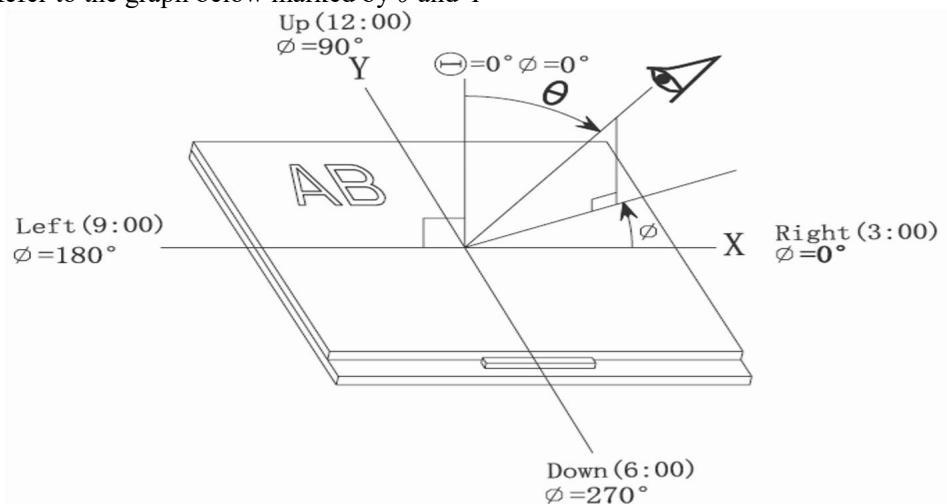

Note 4: Definition of contrast ratio.(Test LCD using DMS501)

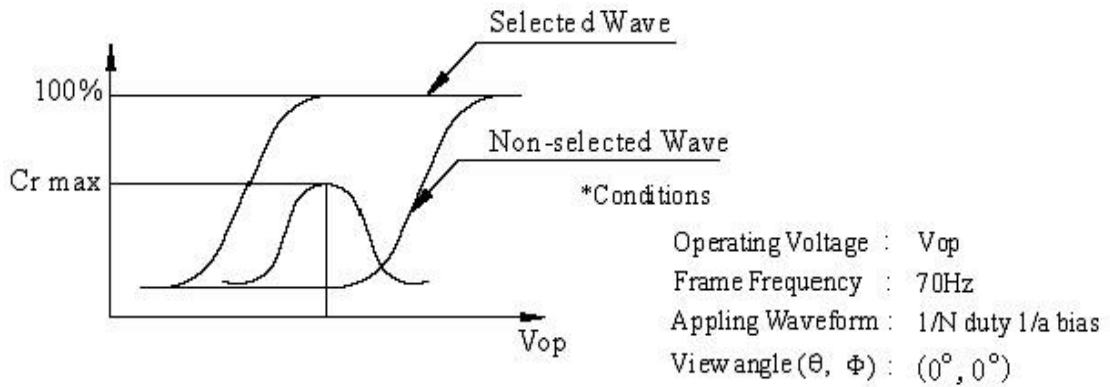

$$\text{Contrast ratio}(Cr) = \frac{\text{Brightness of selected dots}}{\text{Brightness of non-selected dots}}$$

Note 5: Definition of Response time. (Test LCD using DMS501):

The output signals of photo detector are measured when the input signals are changed from “black” to “white”(falling time) and from “white” to “black”(rising time), respectively. The response time is defined as the time interval between the 10% and 90% of amplitudes. Refer to figure as below.

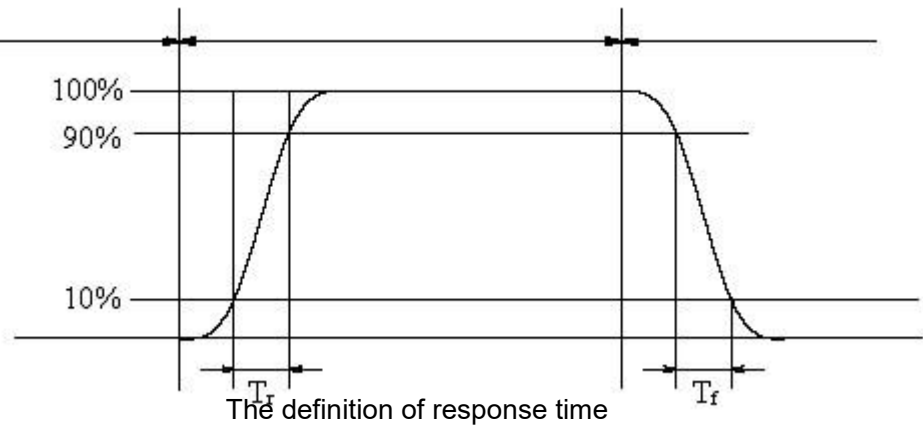

Note 6: Definition of Color of CIE Coordinate and NTSC Ratio.

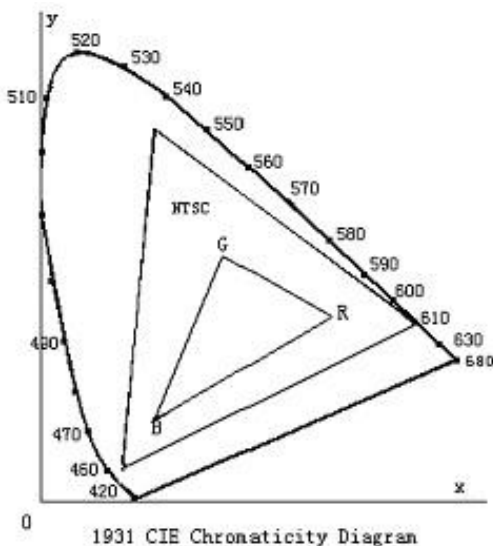

Note 7: Definition of cross talk.

$$\text{Cross talk ratio(\%)} = \frac{|\text{pattern A Brightness} - \text{pattern B Brightness}|}{\text{pattern A Brightness}} * 100$$

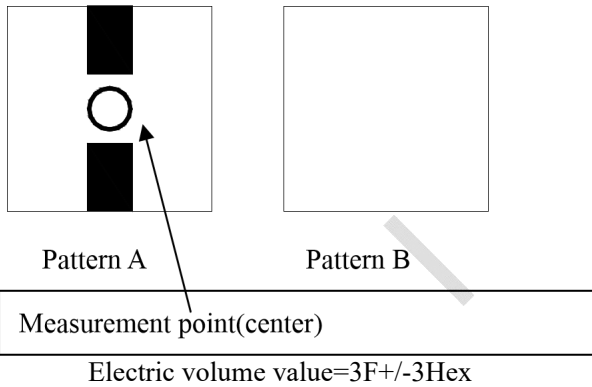

9.0 LVDS Receiver DC Specifications

Over recommended operating supply and temperature range unless otherwise specified

Symbol	Parameter	Conditions	Min	Typ*	Max	Unit
V_{TH}	Differential Input High Threshold	RL=100Ω, VIC=+1.2V	-	-	100	mV
V_{TL}	Differential Input Low Threshold		-100	-	-	mV
I_{IN}	Input Current	$V_{IN} = +2.4 / 0V$ VCC = 3.6V	-	-	±10	μA

9.1 LVDS Receiver AC Specifications

Over recommended operating supply and temperature range unless otherwise specified

Symbol	Parameter	Min	Typ	Max	Unit	
t_{RCP}	CLKOUT Transition Time	VCC = 2.5V to 2.7V	14.3	T	50.0	ns
		VCC = 2.7V to 3.0V	14.3	T	66.6	
		VCC = 3.0V to 3.6V	11.8	T	66.6	
t_{RCH}	CLKOUT High Time	-	4T/7	-	ns	
t_{RCL}	CLKOUT Low Time	-	3T/7	-	ns	
t_{RCD}	RCLK IN to CLK OUT +/- Delay	-	5T/7	-	ns	
t_{RS}	LVC MOS/TTL Data Setup to CLK OUT	0.35T - 0.3	-	-	ns	
t_{RH}	LVC MOS/TTL Data Hold from CLK OUT	0.45T - 1.6	-	-	ns	
t_{TLH}	LVC MOS/TTL Low to High Transition Time	-	2.0	3.0	ns	
t_{THL}	LVC MOS/TTL High to Low Transition Time	-	1.8	3.0	ns	
t_{RIP1}	Input Data Position0 (T=11.76ns)	-0.4	0.0	+0.4	ns	
t_{RIP0}	Input Data Position1 (T=11.76ns)	T/7-0.4	T/7	T/7+0.4	ns	
t_{RIP6}	Input Data Position2 (T=11.76ns)	2T/7-0.4	2T/7	2T/7+0.4	ns	
t_{RIP5}	Input Data Position3 (T=11.76ns)	3T/7-0.4	3T/7	3T/7+0.4	ns	
t_{RIP4}	Input Data Position4 (T=11.76ns)	4T/7-0.4	4T/7	4T/7+0.4	ns	
t_{RIP3}	Input Data Position5 (T=11.76ns)	5T/7-0.4	5T/7	5T/7+0.4	ns	
t_{RIP2}	Input Data Position6 (T=11.76ns)	6T/7-0.4	6T/7	6T/7+0.4	ns	
t_{RPLL}	Phase Lock Loop Set	-	-	10.0	ms	

*Typ values are at the conditions of VCC=3.3V and Ta = +25°C



10.0 AC Timing Diagrams

LVDS Input Data Position

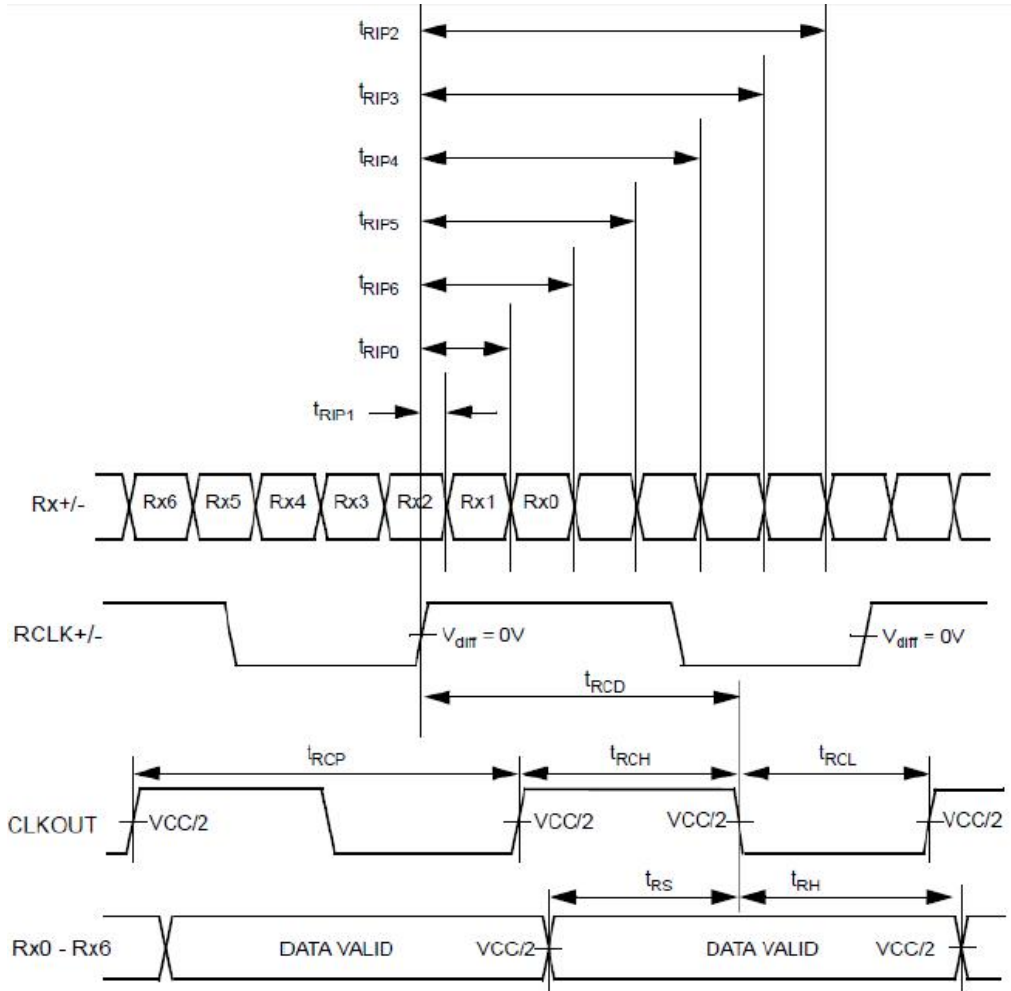

10.1 Phase Lock Loop set time

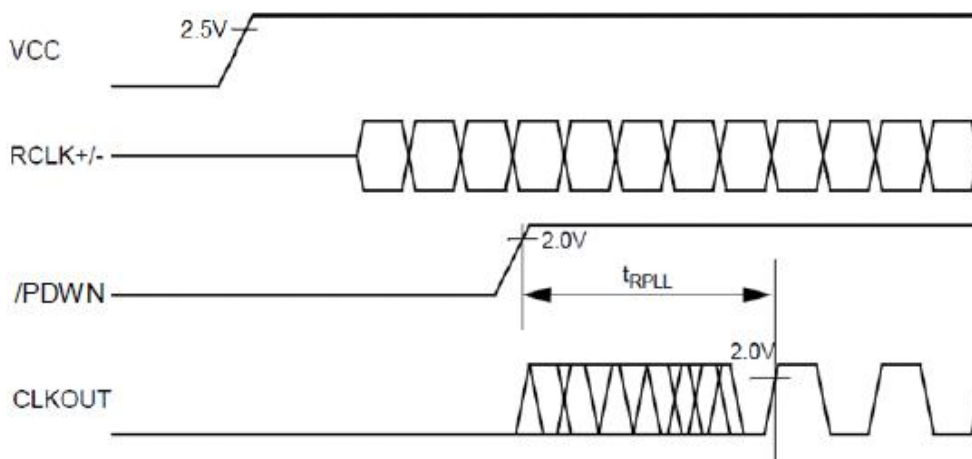



11.0 TTL Data Timing Diagram

Following are THC63LVDM83D TTL data input timing example for XGA (1024x768).

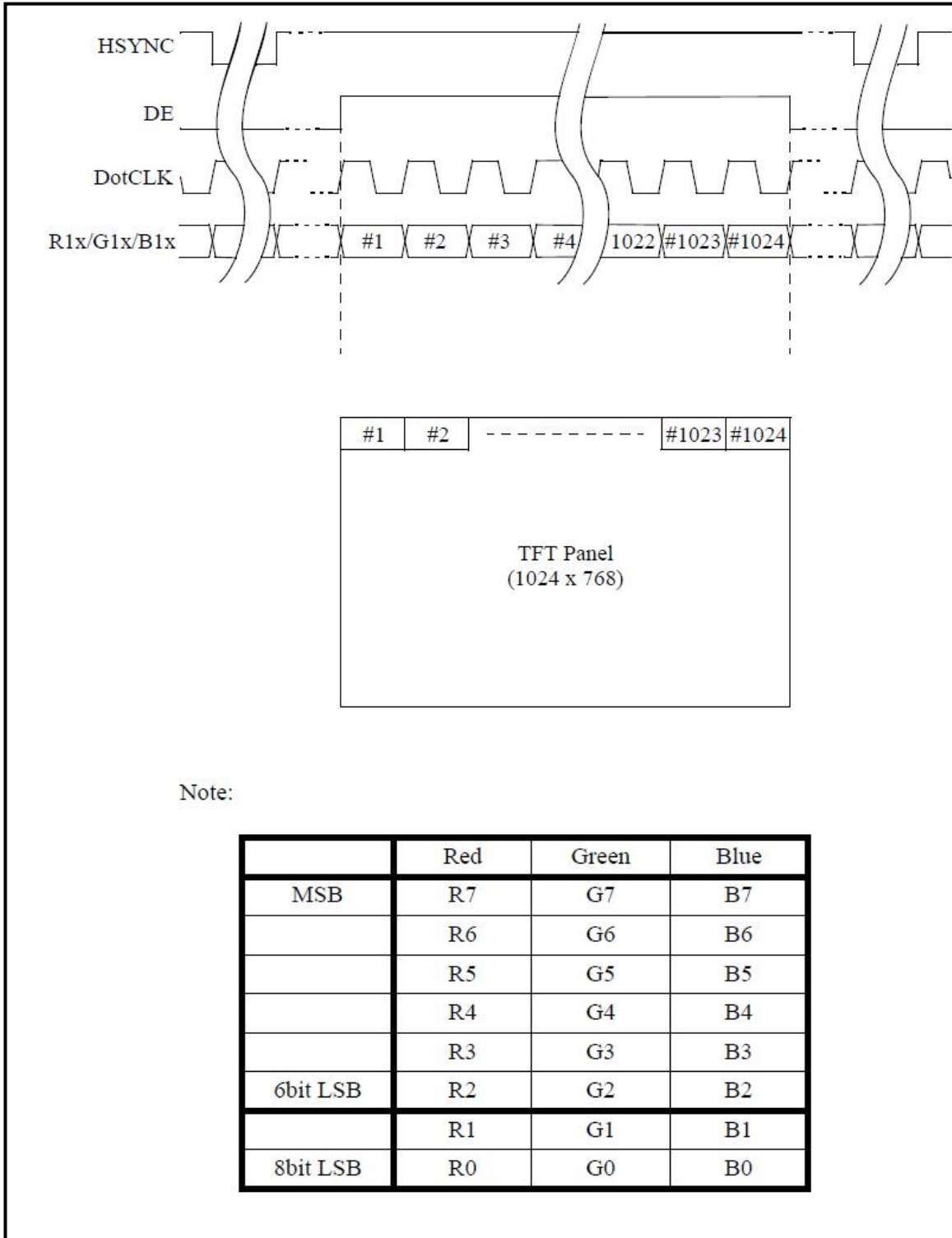



11.1 LVDS Data Timing Diagram

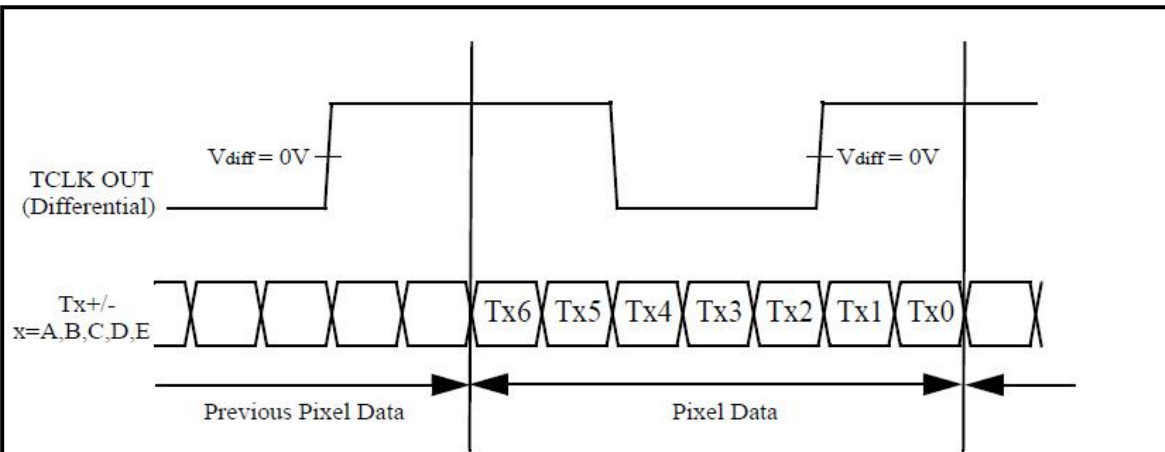

Pixel Data Mapping for VESA Format (6bit, 8bit Application)

TX Pin	6bit	8bit	RX Pin
TA0	R0	R0	RA0
TA1	R1	R1	RA1
TA2	R2	R2	RA2
TA3	R3	R3	RA3
TA4	R4	R4	RA4
TA5	R5	R5	RA5
TA6	G0	G0	RA6
TB0	G1	G1	RB0
TB1	G2	G2	RB1
TB2	G3	G3	RB2
TB3	G4	G4	RB3
TB4	G5	G5	RB4
TB5	B0	B0	RB5
TB6	B1	B1	RB6
TC0	B2	B2	RC0
TC1	B3	B3	RC1
TC2	B4	B4	RC2
TC3	B5	B5	RC3
TC4	Hsync	Hsync	RC4
TC5	Vsync	Vsync	RC5
TC6	DE	DE	RC6
TD0	-	R6	RD0
TD1	-	R7	RD1
TD2	-	G6	RD2
TD3	-	G7	RD3
TD4	-	B6	RD4
TD5	-	B7	RD5
TD6	-	N/A	RD6

Note : Use TA to TC channels and open TD channel for 6bit application.



12.0 Block Diagram

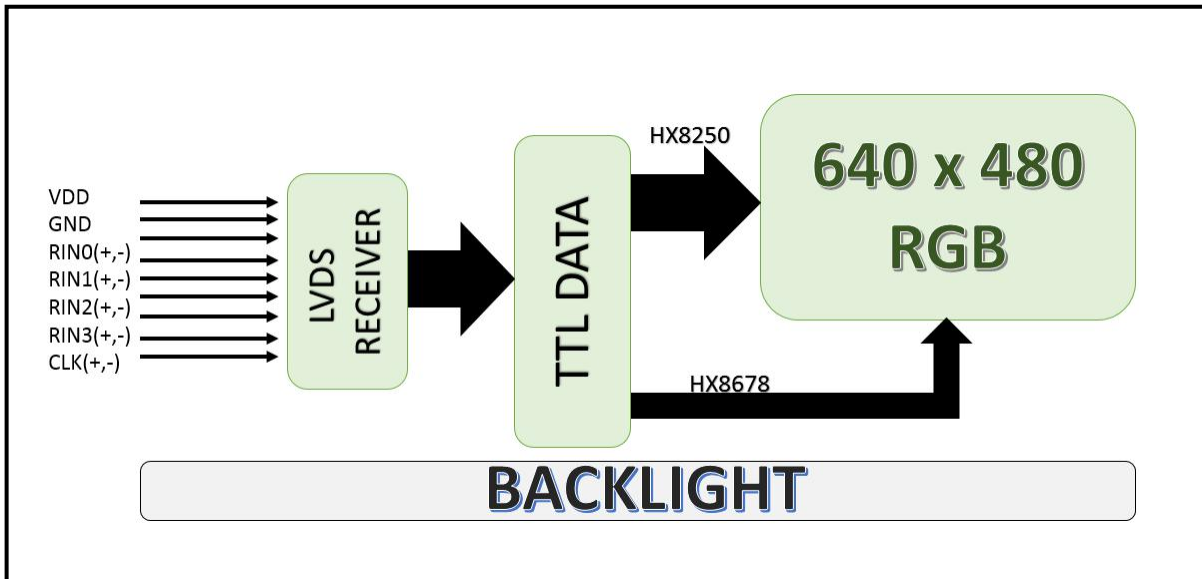

13.0 Inspection criteria

No	Defect	Definition of defect	Inspection Criteria														
1	a) Definition of dot	<p>The size of defective dot over 1/2 of whole is regards as one defective dot.</p> <p>Smaller than 1/2 Larger than 1/2</p> <p>'No dot defect' (ignore) '1 dot defect' (counted)</p>	<p>A – Viewing area B – Viewing area C – Outside Viewing area</p>														
	b) Bright Dot	Dot appear bright and unchanged in size when LCD panel is displaying black pattern	<table border="1"> <thead> <tr> <th>Defect</th> <th>A</th> <th>B</th> <th>C</th> </tr> </thead> <tbody> <tr> <td>Bright Dot</td> <td>1</td> <td>1</td> <td rowspan="3">NC</td> </tr> <tr> <td>Dark Dot</td> <td>2</td> <td>2</td> </tr> <tr> <td>Total</td> <td colspan="2">4</td> </tr> </tbody> </table> <p>NC – Not Count</p>	Defect	A	B	C	Bright Dot	1	1	NC	Dark Dot	2	2	Total	4	
	Defect	A		B	C												
	Bright Dot	1	1	NC													
Dark Dot	2	2															
Total	4																
c) Dark Dot	Dot appear dark and unchanged in size when LCD panel is displaying pure color (RED, GREEN or BLUE) pattern																
d) 2 dot adjacent	<p>1 pair = 2 dots</p> <p>Type 1 Type 2</p> <p>or</p> <p>Type 3</p>	<table border="1"> <thead> <tr> <th>Defect</th> <th>Acc. Count</th> </tr> </thead> <tbody> <tr> <td>2 Bright dot Adjacent</td> <td>0</td> </tr> <tr> <td>2 Dark dot Adjacent</td> <td>1</td> </tr> </tbody> </table>	Defect	Acc. Count	2 Bright dot Adjacent	0	2 Dark dot Adjacent	1									
Defect	Acc. Count																
2 Bright dot Adjacent	0																
2 Dark dot Adjacent	1																
2	<p>Black spot White Spot Bright spot Pin Hole Foreign Particle</p> <p>-Black/Dark/Bright Spot is points on display which appear dark/bright and usually result from contamination - These defect do not vary in size intensity (contrast) when kontras is varied.</p> <p>$D = \frac{a+b}{2}(\text{mm})$</p>	<table border="1"> <thead> <tr> <th>Defect Category</th> <th>A</th> <th>B</th> </tr> </thead> <tbody> <tr> <td>$D \leq 0.10$</td> <td>NC</td> <td rowspan="4">NC</td> </tr> <tr> <td>$0.10 \leq D \leq 0.20$</td> <td>2</td> </tr> <tr> <td>$0.20 \leq D \leq 0.30$</td> <td>1</td> </tr> <tr> <td>$D \geq 0.30$</td> <td>0</td> </tr> </tbody> </table>	Defect Category	A	B	$D \leq 0.10$	NC	NC	$0.10 \leq D \leq 0.20$	2	$0.20 \leq D \leq 0.30$	1	$D \geq 0.30$	0			
Defect Category	A	B															
$D \leq 0.10$	NC	NC															
$0.10 \leq D \leq 0.20$	2																
$0.20 \leq D \leq 0.30$	1																
$D \geq 0.30$	0																
3	<p>Black Line White line Particle between POL and Glass Scratch on Glass</p>	<table border="1"> <thead> <tr> <th>Defect Category</th> <th>A</th> <th>B</th> </tr> </thead> <tbody> <tr> <td>$W \leq 0.03$</td> <td>NC</td> <td rowspan="3">NC</td> </tr> <tr> <td>$0.03 \leq W \leq 0.08, L \leq 2.0$</td> <td>2</td> </tr> <tr> <td>$W \geq 0.08$</td> <td>0</td> </tr> </tbody> </table>	Defect Category	A	B	$W \leq 0.03$	NC	NC	$0.03 \leq W \leq 0.08, L \leq 2.0$	2	$W \geq 0.08$	0					
Defect Category	A	B															
$W \leq 0.03$	NC	NC															
$0.03 \leq W \leq 0.08, L \leq 2.0$	2																
$W \geq 0.08$	0																
4	<p>POL Bubble POL Dented</p>	<table border="1"> <thead> <tr> <th>Defect Category</th> <th>A</th> <th>B</th> </tr> </thead> <tbody> <tr> <td>$D \leq 0.20$</td> <td>NC</td> <td rowspan="4">NC</td> </tr> <tr> <td>$0.20 \leq D \leq 0.30$</td> <td>3</td> </tr> <tr> <td>$0.30 \leq D \leq 0.50$</td> <td>2</td> </tr> <tr> <td>$D \geq 0.5$</td> <td>0</td> </tr> </tbody> </table>	Defect Category	A	B	$D \leq 0.20$	NC	NC	$0.20 \leq D \leq 0.30$	3	$0.30 \leq D \leq 0.50$	2	$D \geq 0.5$	0			
Defect Category	A	B															
$D \leq 0.20$	NC	NC															
$0.20 \leq D \leq 0.30$	3																
$0.30 \leq D \leq 0.50$	2																
$D \geq 0.5$	0																
5	<p>Mura (50% Grey)</p>	<p>Judged by Limit sample</p>															



14. Precaution for Using TFT Modules

1. Handling Precautions

- a. The display panel is made of glass and polarizer. As glass is fragile. It tends to chip during handling especially on the edges. Please avoid dropping or jarring. Do not subject it to a mechanical shock of impact or by dropping it.
- b. If the display panel is damaged and the liquid crystal substance leaks out, be sure not to get any in your mouth. If the substance is in contact with your skin or clothes, wash it off using soap and water.
- c. Do not apply excessive force to the display surface or the adjoining areas since this may cause the colour tone to vary. Do not touch the display with bare hands. This will stain the display area and degrade the insulation between terminals. Scratch and dents may occur on polarizer too.
- d. The polarizer covering the display surface of the LCD module is soft and easily scratched. Handle this polarizer carefully. Do not touch, push or rub the exposed polarizers with anything harder than a HB pencil lead (glass, tweezers, etc.). Do not put or attach anything on the display area to avoid leaving marks on it. Condensation on the surface and contact with terminals due to cold will damage, stain or dirty the polarizer. After products are tested at low temperature they must be warmed up in a container before coming in to contact with room temperature air.
- e. If the display surface becomes contaminated, breathe on the surface and gently wipe it with a soft dry cloth. If it is heavily contaminated, moisten cloth with one of the following solvents
 - Isopropyl alcohol
 - Ethyl alcohol
 - Do not scrub hard to avoid damaging the display surface.
- f. Solvents other than those above-mentioned may damage the polarizer. Especially, do not use the following.
 - Water
 - Ketone
 - Aromatic solvents
 - Wipe off saliva or water drops immediately, contact with water over a long period of time may cause deformation or colour fading. Avoid contact with oil and fats.
- g. Exercise care to minimize corrosion of the electrode. Corrosion of the electrodes is accelerated by water droplets, moisture condensation or a current flow in a high-humidity environment.
- h. Install the LCD Module by using the mounting holes. When mounting the LCD module make sure it is free of twisting, warping and distortion. In particular, do not forcibly pull or bend the I/O cable or the backlight cable.
- i. Do not attempt to disassemble or process the LCD module.
- j. NC terminal should be open. Do not connect anything.
- k. If the logic circuit power is off, do not apply the input signals.
- l. Electro-Static Discharge Control. Since this module uses a CMOS LSI, the same careful attention should be paid to electrostatic discharge as for an ordinary CMOS IC. To prevent destruction of the elements by static electricity, be careful to maintain an optimum work environment.
 - Before removing LCM from its packing case or incorporating it into a set, be sure the module and your body have the same electric potential. Be sure to ground the body when handling the LCD modules.
 - Tools required for assembly, such as soldering irons, must be properly grounded. Make certain the AC power source for the soldering iron does not leak. When using an electric screwdriver to attach LCM, the screw driver



should be of ground potentiality to minimize as much as possible any transmission of electromagnetic waves produced sparks coming from the commutator of the motor.

- To reduce the amount of static electricity generated, do not conduct assembly and other work under dry conditions. To reduce the generation of static electricity be careful that the air in the work environment is not too dry. A relative humidity of 50%-60% is recommended. As far as possible make the electric potential of your work clothes and that of the work bench the ground potential.
 - The LCD module is coated with a film to protect the display surface. Exercise care when peeling off this protective film since static electricity may be generated.
- m. Since LCM has been assembled and adjusted with a high degree of precision, avoid applying excessive shocks to the module or making any alterations or modifications to it.
- Do not alter, modify or change the shape of the tab on the metal frame.
 - Do not make extra holes on the printed circuit board, modify its shape or change the positions of components to be attached.
 - Do not damage or modify the pattern writing on the printed circuit board.
 - Absolutely do not modify the zebra rubber strip (conductive rubber) or heat seal connector.
 - Except for soldering the interface, do not make any alterations or modifications with a soldering iron.
 - Do not drop, bend or twist the LCM.

2. Storage Precautions

When storing the LCD modules, the following precaution are necessary.

- a. Store them in a sealed polyethylene bag. If properly sealed, there is no need for the desiccant.
- b. Store them in a dark place. Do not expose to sunlight or fluorescent light, keep the temperature between 0 °C and 35 °C, and keep the relative humidity between 40%RH and 60%RH.
- c. The polarizer surface should not come in contact with any other objects.

3. Others

- a. Liquid crystals solidify under low temperature (below the storage temperature range) leading to defective orientation or the generation of air bubbles (black or white). Air bubbles may also be generated if the module is subject to a low temperature.
- b. If the LCD modules have been operating for a long time showing the same display patterns, the display patterns may remain on the screen as ghost images and a slight contrast irregularity may also appear. A normal operating status can be regained by suspending use for some time. It should be noted that this phenomenon does not adversely affect performance reliability.
- c. To minimize the performance degradation of the LCD modules resulting from destruction caused by static electricity etc. Exercise care to avoid holding the following sections when handling the modules.
 - Exposed area of the printed circuit board.
 - Terminal electrode sections.

4. Using LCD Modules

a. Installing LCD Modules

The hole in the printed circuit board is used to fix LCM as shown in the picture below.

Attend to the following items when installing the LCM.

- b. Cover the surface with a transparent protective plate to protect the polarizer and LC cell.

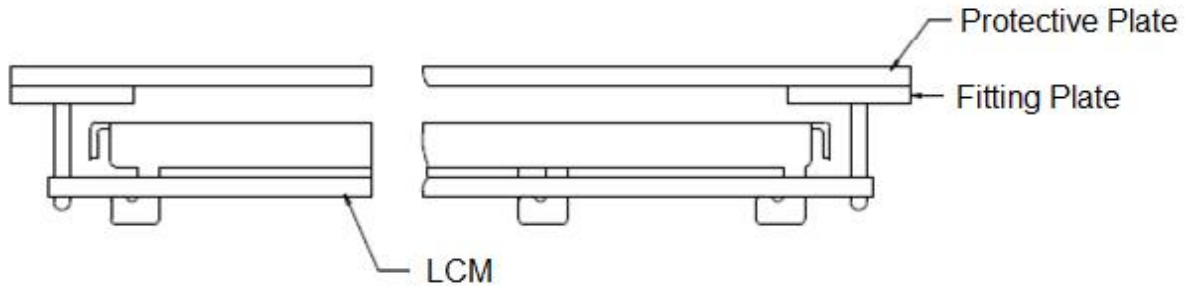

- c. When assembling the LCM into other equipment, the spacer to the bit between the LCM and the fitting plate should have enough height to avoid causing stress to the module surface, refer to the individual specifications for measurements. The measurement tolerance should be 0.1mm.
- d. Precaution for assemble the module with BTB connector:
Please note the position of the male and female connector position, don't assemble or assemble like the method which the following picture shows

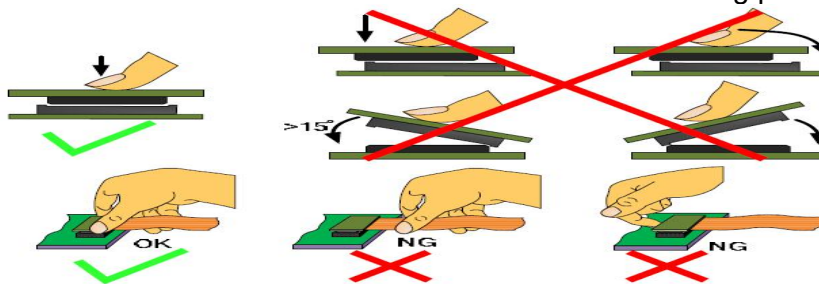

5. Precaution for soldering the LCM

	Manual soldering	Machine drag soldering	Machine press soldering
No RoHS Product	290°C ~350°C. Time: 3-5S.	330°C ~350°C. Speed: 4-8 mm/s.	300°C ~330°C. Time: 3-6S. Press: 0.8~1.2Mpa
RoHS Product	340°C ~370°C. Time: 3-5S.	350°C ~370°C. Time: 4-8 mm/s.	330°C ~360°C. Time: 3-6S. Press: 0.8~1.2Mpa

- a. If soldering flux is used, be sure to remove any remaining flux after finishing the soldering operation (This does not apply in the case of a non-halogen type of flux). It is recommended that you protect the LCD surface with a cover during soldering to prevent any damage due to flux spatters.
- b. When soldering the electroluminescent panel and PC board, the panel and board should not be detached more than three times. This maximum number is determined by the temperature and time conditions mentioned above, though there may be some variance depending on the temperature of the soldering iron.
- c. When removing the electroluminescent panel from the PC board, be sure the solder has completely melted, the soldered pad on the PC board could be damaged.

6. Precautions for Operation

- a. Viewing angle varies with the change of liquid crystal driving voltage (VLCD). Adjust VLCD to show the best contrast.



- b. It is recommended to drive LCD's within the specified voltage limit since over limit will cause shorter LCD life. An electrochemical reaction due to direct current causes LCD-deterioration. Avoid the use of direct current drive.
- c. Response time will be extremely delayed at lower temperature compared to room operating temperature range and on the other hand, at higher temperature LCD-shows dark colour in them. However those phenomena do not mean malfunction. The LCD will return to normal performance when ambient temperature revert to room condition.
- d. If the display area is pushed hard during operation, the display will become abnormal. However, it will return to normal if it is turned off and on.
- e. A slight dew depositing on terminals is a cause for electro-chemical reaction resulting in terminal open circuit.
- f. Input logic voltage before apply analogue high voltage such as LCD driving voltage when power on. Remove analogue high voltage before logic voltage when power off the module. Input each signal after the positive/negative voltage becomes stable.
- g. Please keep the temperature within the specified range for use and storage. Polarization degradation, bubble generation or polarizer peel-off may occur with high temperature and high humidity.

7. Safety

- a. It is recommended to crush damaged or unnecessary LCDs into pieces and wash them off with solvents such as acetone and ethanol, which should later be burned.
- b. If any liquid leaks out of a damaged glass cell and comes in contact with the hands, wash off thoroughly with soap and water.

8. Limited Warranty

Unless otherwise agreed between Crystal Clear Technology and customer, Crystal Clear Technology will replace or repair any of its LCD and LCM which is found to be defective electrically and visually when inspected in accordance with Crystal Clear Technology acceptance standards, for a period of one year from date of shipment. Confirmation of such date shall be based on freight documents. The warranty liability of Crystal Clear Technology is limited to repair and/or replacement on the terms set forth above. Crystal Clear Technology will not responsible for any subsequent or consequential events.

9. Return LCM under Warranty

No warranty can be granted if the precautions stated above have been disregarded.

The typical examples of violations are:

- i. Broken LCD glass
- ii. PCB eyelet's damaged or modified
- iii. PCB conductors damaged
- iv. Circuit modified in any way, including addition of components.
- v. PCB tampered with by grinding, engraving or painting varnish.
- vi. Soldering to, or modifying the bezel in any manner.

Module repairs will be invoiced to customer upon mutual agreement. Modules must be returned with sufficient description of failure or defects. Any connectors or cable installed by customer must be removed completely without damaging the PCB eyelet's, conductors and terminals.

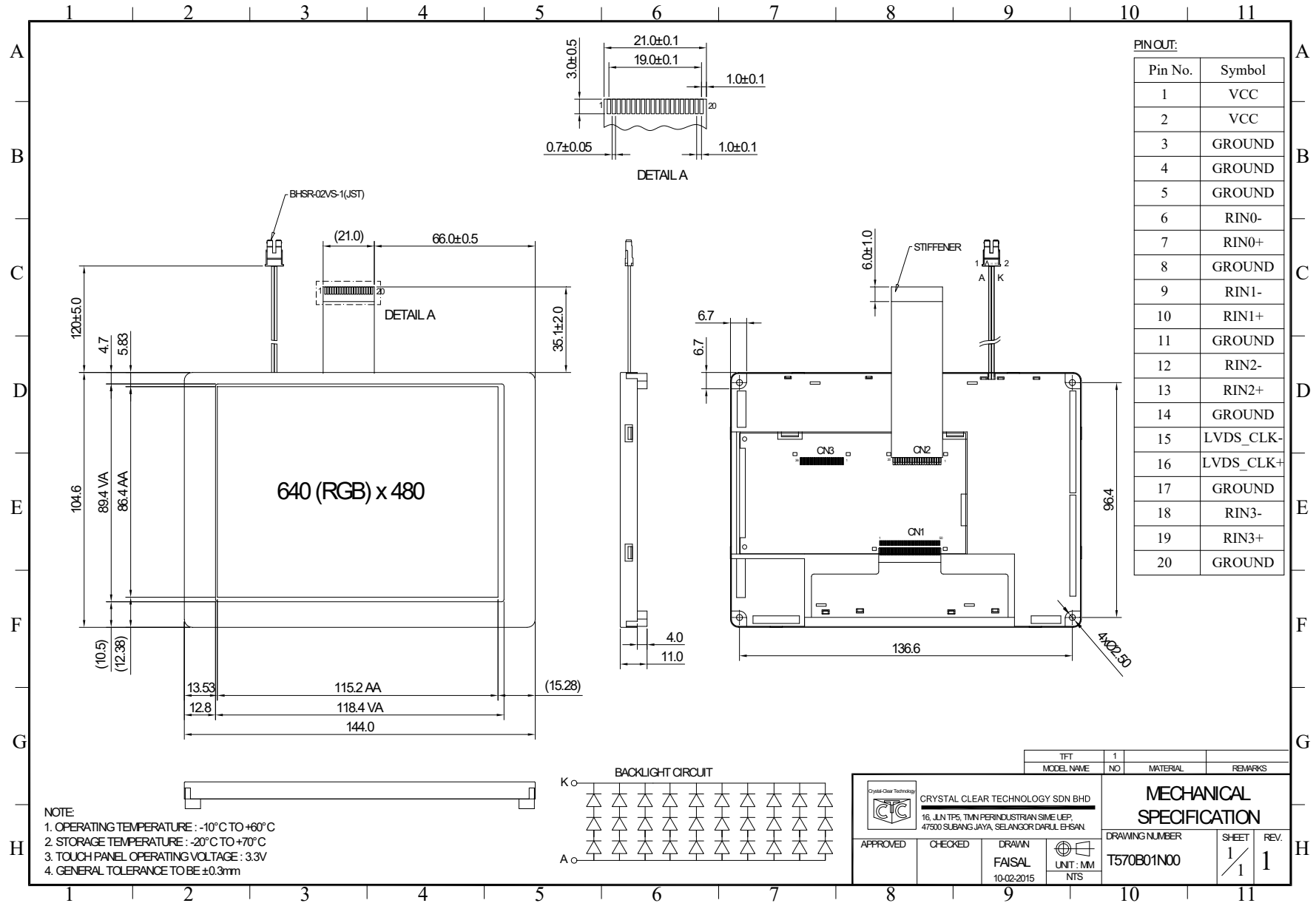



Crystal Clear Technology
16 Jalan TP5—Taman Perindustrian Sime UEP
47600 Subang Jaya—Selangor DE
Malaysia