

K-no.: 24513
6 A Current Sensor for 5V- Supply Voltage

 For electronic current measurement:
 DC, AC, pulsed, mixed ..., with a galvanic
 isolation between primary circuit
 (high power) and secondary circuit
 (electronic circuit)

Date: 11.08.2014
Customer: Standard type
Customers Part no.:
Page 1 of 2
Description

- Closed loop (compensation)
Current Sensor with magnetic field probe
- Printed circuit board mounting
- Casing and materials UL-listed

Characteristics

- Excellent accuracy
- Very low offset current
- Very low temperature dependency and offset current drift
- Very low hysteresis of offset current
- Short response time
- Wide frequency bandwidth
- Compact design
- Reduced offset ripple

Applications

Mainly used for stationary operation in industrial applications:

- AC variable speed drives and servo motor drives
- Static converters for DC motor drives
- Battery supplied applications
- Switched Mode Power Supplies (SMPS)
- Power Supplies for welding applications
- Uninterruptible Power Supplies (UPS)

Electrical data – Ratings

I_{PN}	Primary nominal r.m.s. current	6	A
V_{out}	Output voltage @ I_P	$V_{Ref} \pm (0.625 \cdot I_P / I_{PN})$	V
V_{out}	Output voltage @ $I_P=0, T_A=25^\circ C$	$V_{Ref} \pm 0.0053$	V
V_{Ref}	External Reference voltage range	0...4	V
	Internal Reference voltage	2.5 ± 0.005	V
K_N	Turns ratio	1...3 : 2000	

Accuracy – Dynamic performance data

		min.	typ.	max.	Unit
$I_{P,max}$	Max. measuring range	± 20			
X	Accuracy @ $I_{PN}, T_A=25^\circ C$			0.7	%
ϵ_L	Linearity			0.1	%
$V_{out} - V_{Ref}$	Offset voltage @ $I_P=0, T_A=25^\circ C$			± 5.3	mV
$\Delta V_O / V_{Ref} / \Delta T$	Temperature drift of V_{out} @ $I_P=0, V_{Ref}=2,5V, T_A=-40...85^\circ C$	6		30	ppm/ $^\circ C$
t_r	Response time @ 90% von I_{PN}		300		ns
$\Delta t (I_{P,max})$	Delay time at $di/dt = 100 A/\mu s$		200		ns
f	Frequency bandwidth	DC...200			kHz

General data

		min.	typ.	max.	Unit
T_A	Ambient operating temperature	-40		+85	$^\circ C$
T_S	Ambient storage temperature	-40		+85	$^\circ C$
m	Mass		12		g
V_C	Supply voltage	4.75	5	5.25	V
I_C	Current consumption		15		mA

 Constructed and manufactured and tested in accordance with EN 61800-5-1 (Pin 1 - 6 to Pin 7 – 10)
 Reinforced insulation, Insulation material group 1, Pollution degree 2

S_{clear}	Clearance (component without solder pad)	7.4			mm
S_{creep}	Creepage (component without solder pad)	8.0			mm
V_{sys}	System voltage	overvoltage category 3		RMS	300
V_{work}	Working voltage	(tabel 7 acc. to EN61800-5-1) overvoltage category 2		RMS	650
U_{PD}	Rated discharge voltage	peak value			1320

 Note: "According UL 508: Max. potential difference = 600 V_{AC} "

Date	Name	Issue	Amendment
11.08.14	KRe.	83	Marking changed from 4646X663-83 → 4646-X663-83. Electrical data: V_{out} changed. Accuracy-Dynamic: V_{out} changed. CN-14-076

Hrsg.: KB-E editor	Bearb.: DJ designer	KB-PM: Sn. check	freig.: HS released
-----------------------	------------------------	---------------------	------------------------

K-no.: 24513

6 A Current Sensor for 5V- Supply Voltage

For electronic current measurement:
DC, AC, pulsed, mixed ..., with a galvanic
isolation between primary circuit
(high power) and secondary circuit
(electronic circuit)

Date: 11.08.2014

Customer: Standard type

Customers Part no.:

Page 2 of 2

Mechanical outline (mm):

General tolerances DIN ISO 2768-c

Connections:

1...6: \varnothing 1 mm
7..10: 0,46*0,46 mm

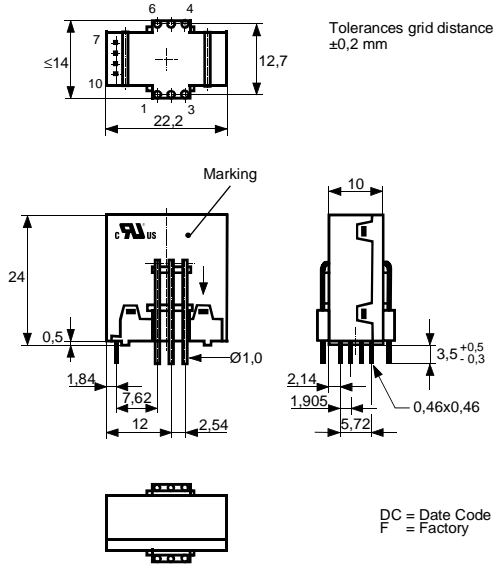

Marking:

VAC UL-sign
4646-X663-83
F DC

Schematic diagram

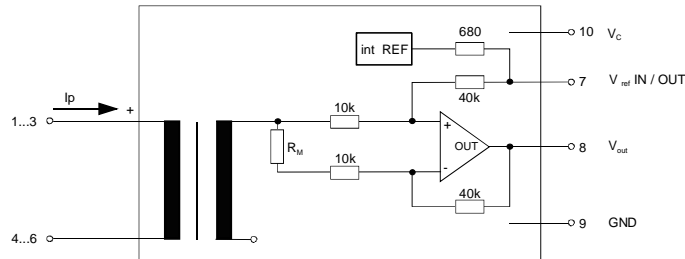

Possibilities of wiring (@ $T_A = 85^\circ\text{C}$)

primary windings	primary current RMS	primary current maximal	output voltage RMS	turns ratio	primary resistance	wiring
N_P	I_P [A]	$\hat{I}_{P,max}$ [A]	$V_{out}(I_P)$ [V]	K_N	R_P [m Ω]	
1	6	± 20	2.5 ± 0.625	1:2000	0.33	
2	3	± 10	2.5 ± 0.625	2:2000	1.5	
3	2	± 6.7	2.5 ± 0.625	3:2000	3	

Temperature of the primary conductor should not exceed 110°C.
Additional information is obtainable on request.
This specification is no declaration of warranty acc. BGB §443

Hrsg.: KB-E
editor

Bearb.: DJ
designer

KB-PM: Sn.
check

freig.: HS
released

K-No.: 24513

6 A Current Sensor for 5V- Supply Voltage

 For the electronic measurement of currents:
 DC, AC, pulsed, mixed ..., with a galvanic
 isolation between the primary circuit
 (high power) and the secondary circuit

Date: 11.08.2014

Customer:
Customers Part No.:
Page 1 **of** 2

Electrical Data

		min.	typ.	max.	Unit
V_{Ctot}	Maximum supply voltage (without function)			7	V
I_C	Supply Current with primary current		15mA + $I_p \cdot K_N + V_{out}/R_L$		mA
$I_{out,SC}$	Short circuit output current		±20		mA
R_P	Resistance / primary winding @ $T_A=25^\circ C$		1		mΩ
R_S	Secondary coil resistance @ $T_A=85^\circ C$			67	Ω
$R_{i,Ref}$	Internal resistance of Reference input		670		Ω
$R_{is}(V_{out})$	Output resistance of V_{out}			1	Ω
R_L	External recommended resistance of V_{out}	1			kΩ
C_L	External recommended capacitance of V_{out}			500	pF
$\Delta X_{Ti} / \Delta T$	Temperature drift of X @ $T_A = -40 \dots +85^\circ C$			40	ppm/K
$\Delta V_0 = \Delta(V_{out} - V_{Ref})$	Sum of any offset drift including:		5	15	mV
V_{0t}	Longtermdrift of V_0		3		mV
V_{0T}	Temperature drift von V_0 @ $T_A = -40 \dots +85^\circ C$		3		mV
V_{0H}	Hysteresis of V_{out} @ $I_p=0$ (after an overload of $10 \times I_{PN}$)			7.5	mV
$\Delta V_0 / \Delta V_C$	Supply voltage rejection ratio			1	mV/V
V_{oss}	Offsetripple (with 1 MHz- filter first order)			55	mV
V_{oss}	Offsetripple (with 100 kHz- filter first order)		9	15	mV
V_{oss}	Offsetripple (with 20 kHz- filter first order)		2.5	4	mV
C_k	Maximum possible coupling capacity (primary – secondary)		5	10	pF
	Mechanical stress according to M3209/3			30g	
	Settings: 10 – 2000 Hz, 1 min/Octave, 2 hours				

Inspection (Measurement after temperature balance of the samples at room temperature), SC = significant characteristic

$V_{out}(SC)$	(V)	M3011/6:	Output voltage vs. external reference ($I_p=6A$, 40-80Hz)	625±0.7%	mV
$V_{out}-V_{Ref}(I_p=0)$	(V)	M3226:	Offset voltage	± 5.3	mV
V_d	(V)	M3014:	Test voltage, rms, 1 s pin 1 – 6 vs. pin 7 – 10	1.5	kV
V_e	(AQL 1/S4)		Partial discharge voltage acc.M3024 (RMS) with V_{vor} (RMS)	1400 1750	V V

Type Testing (Pin 1 - 6 to Pin 7 - 10)

Designed according standard EN 50178 with insulation material group 1

V_W	HV transient test according to M3064 (1,2 μs / 50 μs-wave form)		8	kV
V_d	Testing voltage, to M3014	(5 s)	3	kV
V_e	Partial discharge voltage acc.M3024 (RMS) with V_{vor} (RMS)		1400 1750	V V

Applicable documents

 Current direction: A positive output current appears at point V_{out} , by primary current in direction of the arrow.
 Housing and bobbin material UL-listed: Flammability class 94V-0.
 Enclosures according to IEC529: IP50.

Further standards UL 508 ; file E317483, category NMTR2 / NMTR8

Datum	Name	Index	Ämendment
11.08.14	KRe	83	Electrical data: V_{ctot} changed. Inspection M3011/6 defined as SC-measure. V_{out} changed. CN-14-076
21.12.12	Le	83	Applicable documents added. CN-572

Hrsg.: KB-E editor	Bearb: DJ designer	KB-PM: Sn. check	freig.: HS released
-----------------------	-----------------------	---------------------	------------------------

Weitergabe sowie Vervielfältigung dieser Unterlage, Verwertung und Mitteilung ihres Inhalts nicht gestattet, soweit nicht ausdrücklich zugestanden. Zuwiderhandlungen verpflichten zu Schadenersatz. Alle Rechte für den Fall der Patenterteilung oder GM-Eintragung vorbehalten

 Copying of this document, disclosing it to third parties or using the contents there for any purposes without express written authorization by use illegally forbidden.
 Any offenders are liable to pay all relevant damages.

K-No.: 24513

6 A Current Sensor for 5V- Supply Voltage

 For the electronic measurement of currents:
 DC, AC, pulsed, mixed ..., with a galvanic
 Isolation between the primary circuit
 (high power) and the secondary circuit

Date: 11.08.2014

Customer:
Customers Part No.:
Page 2 **of** 2

Explanation of several of the terms used in the tablets (in alphabetical order)

t: Response time (describe the dynamic performance for the specified measurement range), measured as delay time at $I_P = 0,9 \cdot I_{PN}$ between a rectangular current and the output voltage $V_{out}(I_P)$

$\Delta t (I_{Pmax})$: Delay time (describe the dynamic performance for the rapid current pulse rate e.g short circuit current) measured between I_{Pmax} and the output voltage $V_{out}(I_{Pmax})$ with a primary current rise of $di_P/dt \geq 100 \text{ A}/\mu\text{s}$.

U_{PD} Rated discharge voltage (recurring peak voltage separated by the insulation) proved with a sinusoidal voltage V_e
 $U_{PD} = \sqrt{2} \cdot V_e / 1,5$

V_{vor} Defined voltage is the RMS value of a sinusoidal voltage with peak value of $1,875 \cdot U_{PD}$ required for partial discharge test in IEC 61800-5-1

$$V_{vor} = 1,875 \cdot U_{PD} / \sqrt{2}$$

V_{sys} System voltage RMS value of rated voltage according to IEC 61800-5-1

V_{work} Working voltage voltage according to IEC 61800-5-1 which occurs by design in a circuit or across insulation

V_o : Offset voltage between V_{out} and the rated reference voltage of $V_{ref} = 2,5V$.
 $V_o = V_{out}(0) - 2,5V$

V_{oH} : Zero variation of V_o after overloading with a DC of tenfold the rated value

V_{oT} : Long term drift of V_o after 100 temperature cycles in the range -40 bis 85 °C.

X: Permissible measurement error in the final inspection at RT, defined by

$$X = 100 \cdot \left| \frac{V_{out}(I_{PN}) - V_{out}(0)}{0,625V} - 1 \right| \%$$

$X_{ges}(I_{PN})$: Permissible measurement error including any drifts over the temperature range by the current measurement I_{PN}

$$X_{ges} = 100 \cdot \left| \frac{V_{out}(I_{PN}) - 2,5V}{0,625V} - 1 \right| \% \quad \text{or} \quad X_{ges} = 100 \cdot \left| \frac{V_{out}(I_{PN}) - V_{ref}}{0,625V} - 1 \right| \%$$

ϵ_L : Linearity fault defined by
$$\epsilon_L = 100 \cdot \left| \frac{I_P}{I_{PN}} - \frac{V_{out}(I_P) - V_{out}(0)}{V_{out}(I_{PN}) - V_{out}(0)} \right| \%$$

This "Additional information" is no declaration of warranty according BGB §443.

Hrsg.: KB-E
 editor

Bearb.: DJ
 designer

KB-PM: Sn.
 check

freig.: HS
 released