

Model Name: T645HW04 V0

Issue Date : 2010/5/20

() Preliminary Specifications

(*) Final Specifications

Customer Signature	Date	AUO	Date
Approved By		Approval By PM Director Yenting Chiu <u>Yenting Chiu 2010.6.1</u>	
Note		Reviewed By RD Director Eugene Chen <u>Eugene Chen 2010.5.28</u>	
		Reviewed By Project Leader WL Lin <u>William Lin 2010.5.26</u>	
		Prepared By PM Ryan Chung <u>Ryan Chung 2010.5.20</u>	

Contents

No		
		CONTENTS
		RECORD OF REVISIONS
1		GENERAL DESCRIPTION
2		ABSOLUTE MAXIMUM RATINGS
3		ELECTRICAL SPECIFICATION
	3-1	ELECTRICAL CHARACTERISTICS
	3-2	INTERFACE CONNECTIONS
	3-3	SIGNAL TIMING SPECIFICATION
	3-4	SIGNAL TIMING WAVEFORM
	3-5	COLOR INPUT DATA REFERENCE
	3-6	POWER SEQUENCE
4		OPTICAL SPECIFICATION
5		RELIABILITY TEST ITEMS
6		INTERNATIONAL STANDARD
	6-1	SAFETY
	6-2	EMC
7		PACKING
	7-1	DEFINITION OF LABEL
	7-2	PACKING METHODS
	7-3	PALLET AND SHIPMENT INFORMATION
8		PRECAUTION
	8-1	MOUNTING PRECAUTIONS
	8-2	OPERATING PRECAUTIONS
	8-3	ELECTROSTATIC DISCHARGE CONTROL
	8-4	PRECAUTIONS FOR STRONG LIGHT EXPOSURE
	8-5	STORAGE
	8-6	HANDLING PRECAUTIONS FOR PROTECT FILM

Record of Revision

Version	Date	Page	Description
1.0	2010/05/20		First release
1.1	2010/10/14	11	Signal Timing Specification update

1. General Description

This specification applies to the 64.5 inch Color TFT-LCD Module T645HW04 V0. This LCD module has a TFT active matrix type liquid crystal panel 1920 x 1080 pixels, and diagonal size of 64.5 inch. This module supports 1920 x 1080 mode. Each pixel is divided into Red, Green and Blue sub-pixels or dots which are arranged in vertical stripes. Gray scale or the brightness of the sub-pixel color is determined with a 10-bit gray scale signal for each dot.

The T645HW04 V0 has been designed to apply the 10-bit 4 channel LVDS interface method. It is intended to support displays where high brightness, wide viewing angle, high color saturation, and high color depth are very important.

* General Information

Items	Specification	Unit	Note
Active Screen Size	64.53	inch	
Display Area	1428.48(H) x 803.52(V)	mm	
Outline Dimension	1461.98(H) x 839.24(V)	mm	
Driver Element	a-Si TFT active matrix		
Display Colors	10 bit, 1.07B	Colors	
Number of Pixels	1920 x 1080	Pixel	
Pixel Pitch	0.744	mm	
Pixel Arrangement	RGB vertical stripe		
Display Operation Mode	Normally Black		
Surface Treatment	HCLR		

2. Absolute Maximum Ratings

The followings are maximum values which, if exceeded, may cause faulty operation or damage to the unit

Item	Symbol	Min	Max	Unit	Conditions
Logic/LCD Drive Voltage	V_{DD}	-0.3	14	[Volt]	Note 1
Input Voltage of Signal	V_{in}	-0.3	4	[Volt]	Note 1
Operating Temperature	TOP	0	+50	[°C]	Note 2
Operating Humidity	HOP	10	90	[%RH]	Note 2
Storage Temperature	TST	-20	+60	[°C]	Note 2,4
Storage Humidity	HST	10	90	[%RH]	Note 2,4
Panel Surface Temperature	PST	-	65	[°C]	Note 3

Note 1: Duration:50 msec.

Note 2 : Maximum Wet-Bulb should be 39°C and No condensation.

The relative humidity must not exceed 90% non-condensing at temperatures of 40°C or less. At temperatures greater than 40°C, the wet bulb temperature must not exceed 39°C.

Note 3: Surface temperature is measured at 50°C Dry condition

Note 4: Storage period should refer to RA criteria

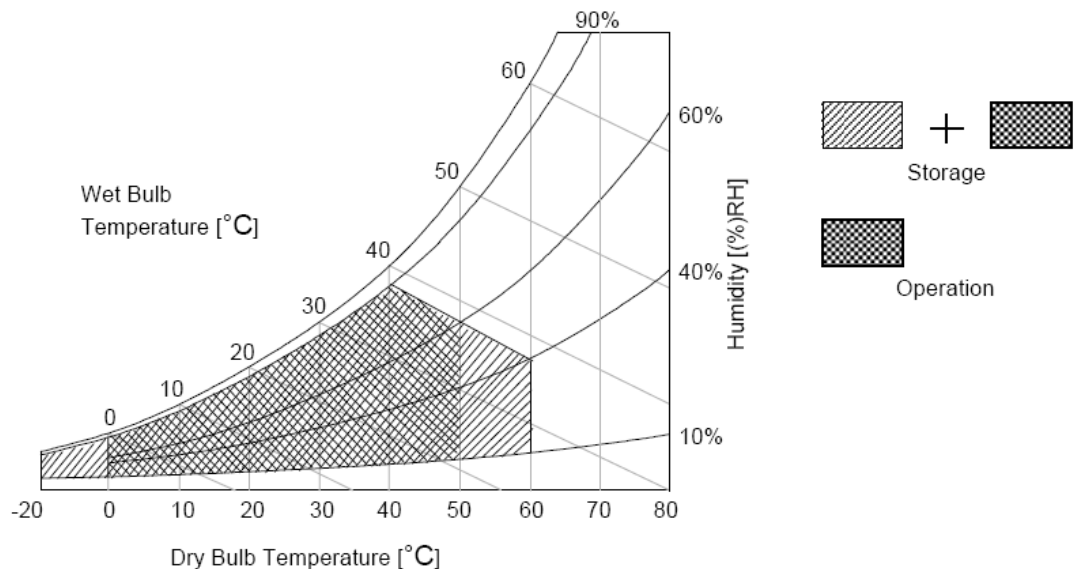

3. Electrical Specification

The T645HW04 V0 requires two power inputs. One is employed to power the LCD electronics and to drive the TFT array and liquid crystal. The second input for BLU is to power inverter.

3.1 Electrical Characteristics

Parameter		Symbol	Value			Unit	Note
			Min.	Typ.	Max		
LCD							
Power Supply Input Voltage		V_{DD}	10.8	12	13.2	V_{DC}	1
Power Supply Input Current		I_{DD}	--	1.65	2.7	A	2
Power Consumption		P_C	--	19.8	32.4	Watt	2
Inrush Current		I_{RUSH}	--	--	6	A	3
LVDS Interface	Differential Input High Threshold Voltage	V_{TH}	--	--	+100	4	4
	Differential Input Low Threshold Voltage	V_{TL}	-100	--	--	4	4
	Input Common Mode Voltage	V_{ICM}	1.10	1.25	1.40	V_{DC}	4
CMOS Interface	Input High Threshold Voltage	V_{IH} (High)	2.7	--	3.3	V_{DC}	--
	Input Low Threshold Voltage	V_{IL} (Low)	0	--	0.6	V_{DC}	--

Note :

1. The ripple voltage should be controlled under 10% of V_{CC}
2. $V_{DD} = 12.0V$, $F_V = 60Hz$, $F_{CLK} = 82MHz$, $25^\circ C$, Test Pattern : White Pattern
>> refer to "Section:3.3 Signal Timing Specification, Typical timing"
3. Measurement condition : Rising time = 400us

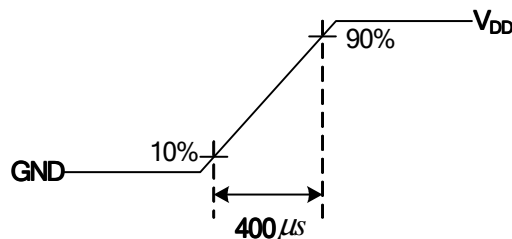

4. $V_{ICM} = 1.25V$

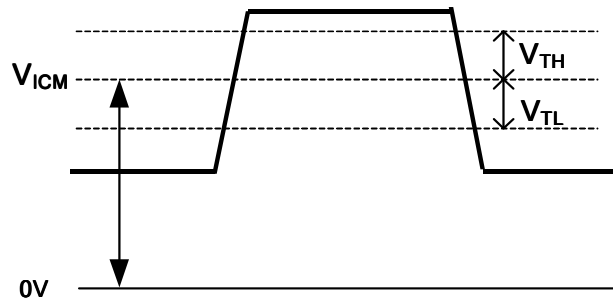

5. Input Channel Pair Skew Margin

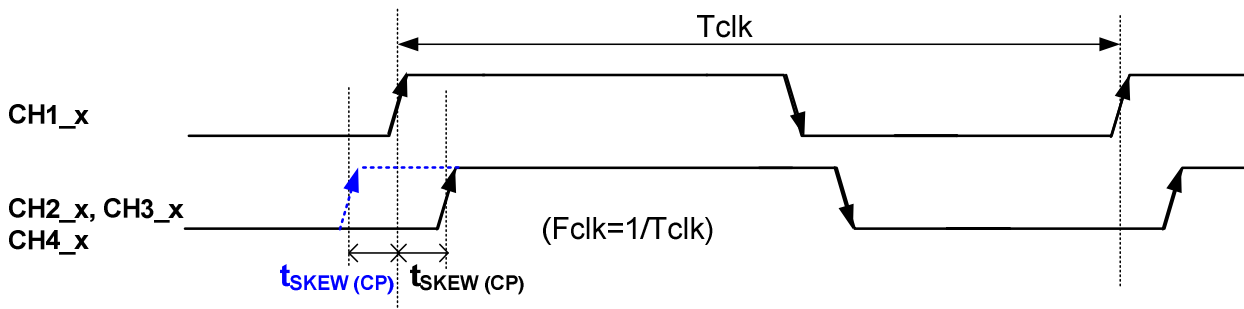

3.2 Interface Connections

- LCD connector: 82pin LVDS connector(UJU, PF050-C82B-C35), Foosung TECH. Co.(FF05001-82)

PIN	Symbol	Description	PIN	Symbol	Description
1	V _{DD}	Power Supply, +12V DC Regulated	26	LE_0+	LVDS Channel Even of Left, Signal 0+
2	V _{DD}	Power Supply, +12V DC Regulated	27	LE_1-	LVDS Channel Even of Left, Signal 1-
3	V _{DD}	Power Supply, +12V DC Regulated	28	LE_1+	LVDS Channel Even of Left, Signal 1+
4	V _{DD}	Power Supply, +12V DC Regulated	29	LE_2-	LVDS Channel Even of Left, Signal 2-
5	V _{DD}	Power Supply, +12V DC Regulated	30	LE_2+	LVDS Channel Even of Left, Signal 2+
6	NC	No connection	31	GND	Ground
7	GND	Ground	32	LE_CLK-	LVDS Channel Even of Left, Clock -
8	GND	Ground	33	LE_CLK+	LVDS Channel Even of Left, Clock +
9	GND	Ground	34	GND	Ground
10	LO_0-	LVDS Channel Odd of Left, Signal 0-	35	LE_3-	LVDS Channel Even of Left, Signal 3-
11	LO_0+	LVDS Channel Odd of Left, Signal 0+	36	LE_3+	LVDS Channel Even of Left, Signal 3+
12	LO_1-	LVDS Channel Odd of Left, Signal 1-	37	LE_4-	LVDS Channel Even of Left, Signal 4-
13	LO_1+	LVDS Channel Odd of Left, Signal 1+	38	LE_4+	LVDS Channel Even of Left, Signal 4+
14	LO_2-	LVDS Channel Odd of Left, Signal 2-	39	GND	Ground
15	LO_2+	LVDS Channel Odd of Left, Signal 2+	40	SCL_T	EEPROM Serial Clock for TCON
16	GND	Ground	41	Hsync_out	Hsync_out
17	LO_CLK-	LVDS Channel Odd of Left, Clock -	42	N240 Sync	N240 Sync
18	LO_CLK+	LVDS Channel Odd of Left, Clock +	43	WP	EEPROM Write Protection High(3.3V) for Writable, Low(GND) for Protection
19	GND	Ground	44	SDA_T	EEPROM Serial Data for TCON
20	LO_3-	LVDS Channel Odd of Left, Signal 3-	45	LVDS_SEL	Open/High(3.3V) for NS, Low(GND) for JEIDA
21	LO_3+	LVDS Channel Odd of Left, Signal 3+	46	SCL_F	EEPROM Serial Clock for FRC
22	LO_4-	LVDS Channel Odd of Left, Signal 4-	47	FRC_nReset	FRC_nReset
23	LO_4+	LVDS Channel Odd of Left, Signal 4+	48	SDA_F	EEPROM Serial Data for FRC
24	GND	Ground	49	SW_PVCC	SW_PVCC
25	LE_0-	LVDS Channel Even of Left, Signal 0-	50	MAIN_Check	MAIN_Check (for FRC)

PIN	Symbol	Description	PIN	Symbol	Description
51	Reserved	AUO Internal Use Only	76	RO_2+	LVDS Channel Odd of Right, Signal 2+
52	GND	Ground	77	RO_2-	LVDS Channel Odd of Right, Signal 2-
53	RE_4+	LVDS Channel Even of Right, Signal 4+	78	RO_1+	LVDS Channel Odd of Right, Signal 1+
54	RE_4-	LVDS Channel Even of Right, Signal 4-	79	RO_1-	LVDS Channel Odd of Right, Signal 1-
55	RE_3+	LVDS Channel Even of Right, Signal 3+	80	RO_0+	LVDS Channel Odd of Right, Signal 0+
56	RE_3-	LVDS Channel Even of Right, Signal 3-	81	RO_0-	LVDS Channel Odd of Right, Signal 0-
57	GND	Ground	82	GND	Ground
58	RE_CLK+	LVDS Channel Even of Right, Clock +			
59	RE_CLK-	LVDS Channel Even of Right, Clock -			
60	GND	Ground			
61	RE_2+	LVDS Channel Even of Right, Signal 2+			
62	RE_2-	LVDS Channel Even of Right, Signal 2-			
63	RE_1+	LVDS Channel Even of Right, Signal 1+			
64	RE_1-	LVDS Channel Even of Right, Signal 1-			
65	RE_0+	LVDS Channel Even of Right, Signal 0+			
66	RE_0-	LVDS Channel Even of Right, Signal 0-			
67	GND	Ground			
68	RO_4+	LVDS Channel Odd of Right, Signal 4+			
69	RO_4-	LVDS Channel Odd of Right, Signal 4-			
70	RO_3+	LVDS Channel Odd of Right, Signal 3+			
71	RO_3-	LVDS Channel Odd of Right, Signal 3-			
72	GND	Ground			
73	RO_CLK+	LVDS Channel Odd of Right, Clock +			
74	RO_CLK-	LVDS Channel Odd of Right, Clock -			
75	GND	Ground			

LVDS Option = High/Open→NS

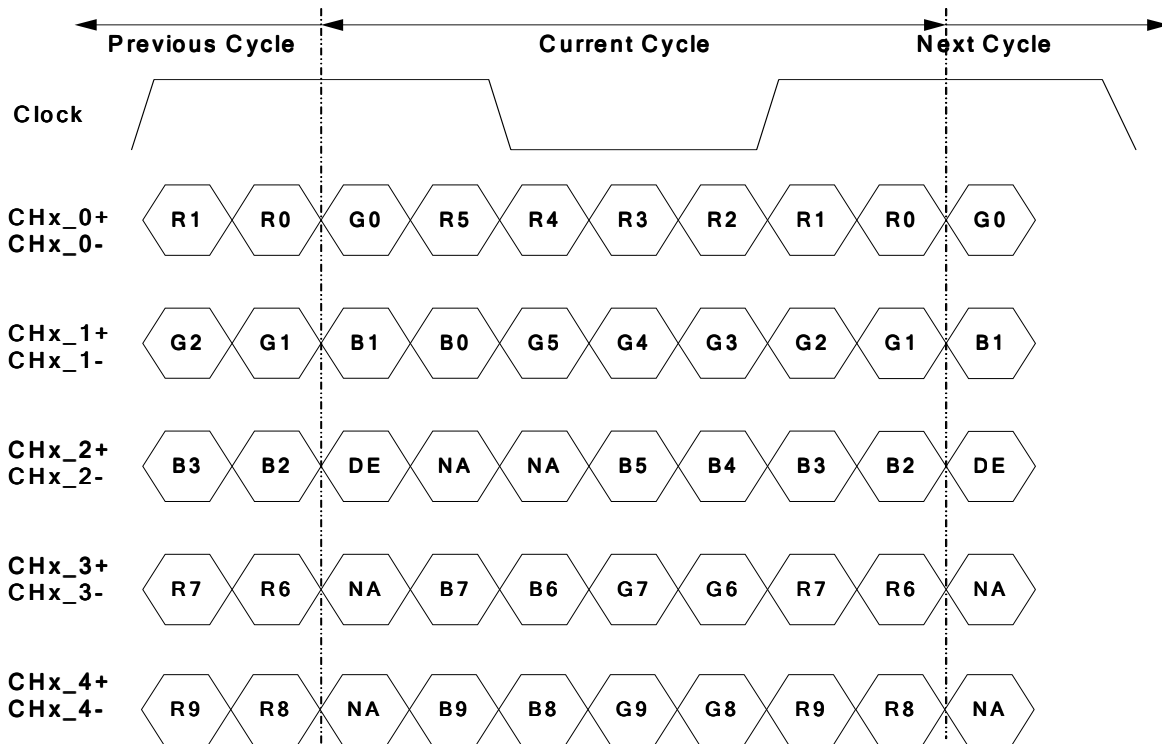

Note: x = 1, 2, 3, 4...

LVDS Option = Low→JEIDA

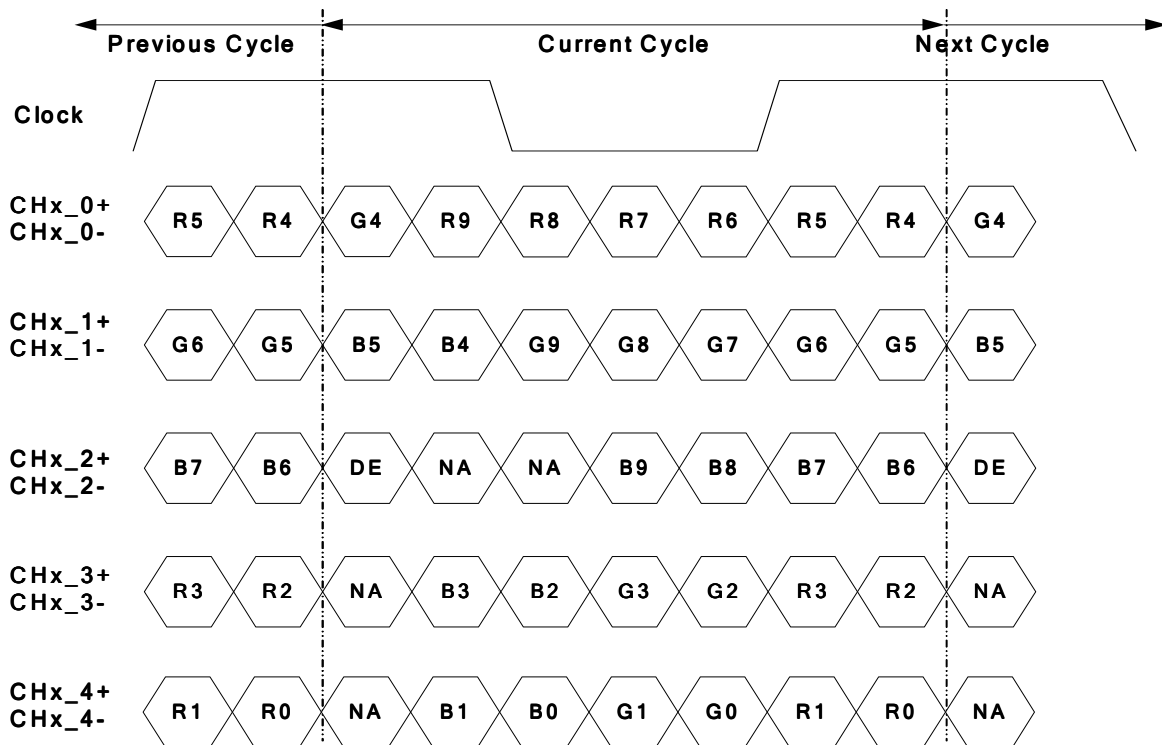

Note: x = 1, 2, 3, 4...

3.3 Signal Timing Specification

This is the signal timing required at the input of the user connector. All of the interface signal timing should be satisfied with the following specifications for its proper operation.

Signal	Item	Min.	Typ.	Max	Unit
Vertical Section	Period		1110		Th
	Active	1080			Th
	Front Porch		21		Th
	Sync Width		4		Th
	Back Porch		5		Th
Horizontal Section	Period		2140		Tclk
	Active	1920			Tclk
	Front Porch		26		Th
	Sync Width		44		Th
	Back Porch		150		Tclk
Clock	Frequency		142.524		MHz
Vertical Frequency	Frequency		60		Hz
Horizontal Frequency	Frequency		66.6		KHz

Notes:

(1) Display position is specific by the rise of DE signal only.

Horizontal display position is specified by the rising edge of 1st DCLK after the rise of 1st DE, is displayed on the left edge of the screen.

(2) Vertical display position is specified by the rise of DE after a “Low” level period equivalent to eight times of horizontal period. The 1st data corresponding to one horizontal line after the rise of 1st DE is displayed at the top line of screen.

(3) If a period of DE “High” is less than 1920 DCLK or less than 1080 lines, the rest of the screen displays black.

(4) The display position does not fit to the screen if a period of DE “High” and the effective data period do not synchronize with each other.

3.4 Signal Timing Waveforms

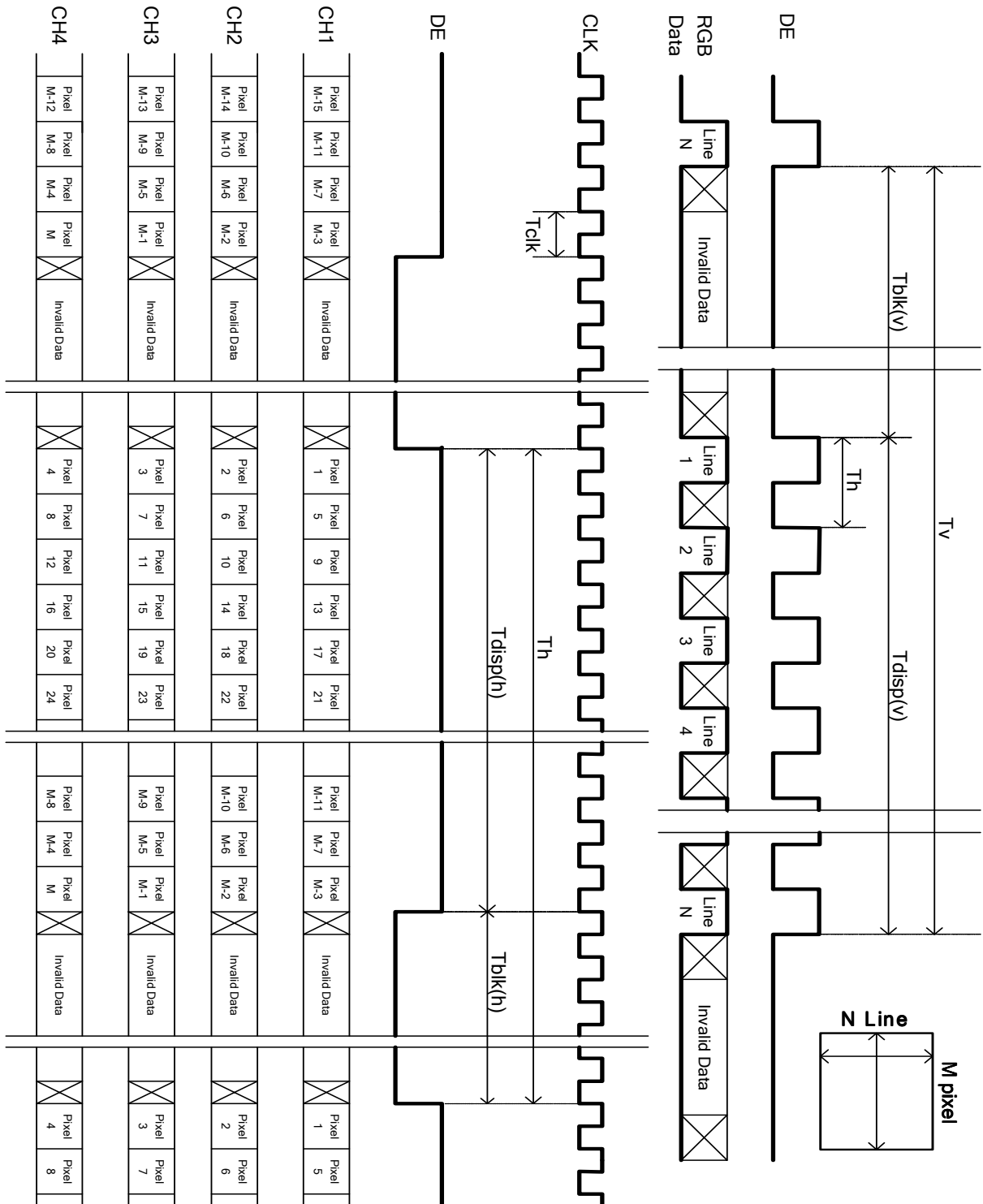

3.5 Color Input Data Reference

The brightness of each primary color (red, green and blue) is based on the 10 bit gray scale data input for the color; the higher the binary input, the brighter the color. The table below provides a reference for color versus data input.

Color Data Reference

Color		Input Color Data																													
		RED										GREEN										BLUE									
		MSB					LSB					MSB					LSB					MSB			LSB						
		R9	R8	R7	R6	R5	R4	R3	R2	R1	R0	G9	G8	G7	G6	G5	G4	G3	G2	G1	G0	B9	B8	B7	B6	B5	B4	B3	B2	B1	B0
Basic Color	Black	0	0	0	0	0	0	0	0	0	0	0	0	0	0	0	0	0	0	0	0	0	0	0	0	0	0	0	0	0	0
	Red(1023)	1	1	1	1	1	1	1	1	1	1	0	0	0	0	0	0	0	0	0	0	0	0	0	0	0	0	0	0	0	0
	Green(1023)	0	0	0	0	0	0	0	0	0	0	1	1	1	1	1	1	1	1	1	1	0	0	0	0	0	0	0	0	0	0
	Blue(1023)	0	0	0	0	0	0	0	0	0	0	0	0	0	0	0	0	0	0	0	0	1	1	1	1	1	1	1	1	1	1
	Cyan	0	0	0	0	0	0	0	0	0	0	1	1	1	1	1	1	1	1	1	1	1	1	1	1	1	1	1	1	1	1
	Magenta	1	1	1	1	1	1	1	1	1	1	0	0	0	0	0	0	0	0	0	0	1	1	1	1	1	1	1	1	1	1
	Yellow	1	1	1	1	1	1	1	1	1	1	1	1	1	1	1	1	1	1	1	1	0	0	0	0	0	0	0	0	0	0
	White	1	1	1	1	1	1	1	1	1	1	1	1	1	1	1	1	1	1	1	1	1	1	1	1	1	1	1	1	1	1
R	RED(000)	0	0	0	0	0	0	0	0	0	0	0	0	0	0	0	0	0	0	0	0	0	0	0	0	0	0	0	0	0	
	RED(001)	0	0	0	0	0	0	0	0	1	0	0	0	0	0	0	0	0	0	0	0	0	0	0	0	0	0	0	0	0	

	RED(1022)	1	1	1	1	1	1	1	1	0	0	0	0	0	0	0	0	0	0	0	0	0	0	0	0	0	0	0	0	0	
	RED(1023)	1	1	1	1	1	1	1	1	1	0	0	0	0	0	0	0	0	0	0	0	0	0	0	0	0	0	0	0	0	
G	GREEN(000)	0	0	0	0	0	0	0	0	0	0	0	0	0	0	0	0	0	0	0	0	0	0	0	0	0	0	0	0	0	
	GREEN(001)	0	0	0	0	0	0	0	0	0	0	0	0	0	0	0	0	0	0	1	0	0	0	0	0	0	0	0	0	0	

	GREEN(1022)	0	0	0	0	0	0	0	0	0	1	1	1	1	1	1	1	1	1	0	0	0	0	0	0	0	0	0	0	0	
	GREEN(1023)	0	0	0	0	0	0	0	0	0	1	1	1	1	1	1	1	1	1	1	0	0	0	0	0	0	0	0	0	0	
B	BLUE(000)	0	0	0	0	0	0	0	0	0	0	0	0	0	0	0	0	0	0	0	0	0	0	0	0	0	0	0	0	0	
	BLUE(001)	0	0	0	0	0	0	0	0	0	0	0	0	0	0	0	0	0	0	0	0	0	0	0	0	0	0	0	0	1	

	BLUE(1022)	0	0	0	0	0	0	0	0	0	0	0	0	0	0	0	0	0	0	0	1	1	1	1	1	1	1	1	1	0	
	BLUE(1023)	0	0	0	0	0	0	0	0	0	0	0	0	0	0	0	0	0	0	0	1	1	1	1	1	1	1	1	1	1	

3.6 Power Sequence for LCD

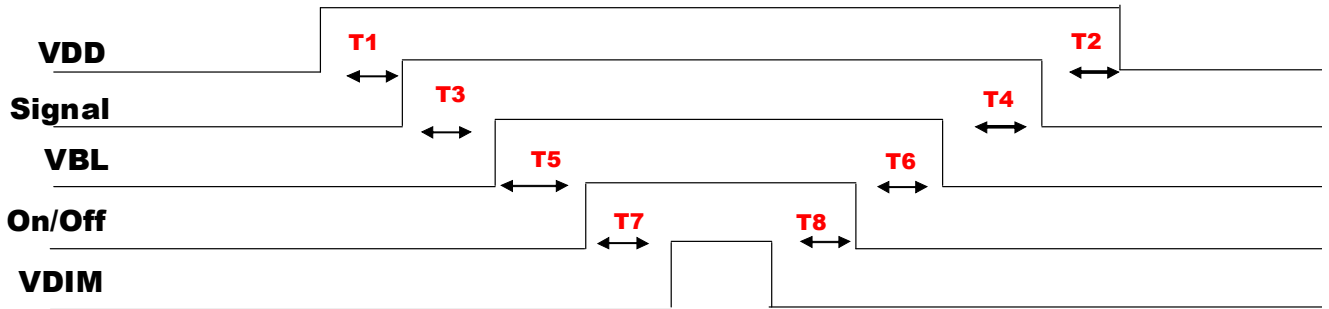

Parameter	Values			Unit
	Min.	Type.	Max.	
t1	0.5	---	80	ms
t2	0.7	---	350	ms
t3	2300	---	---	ms
t4	10 ^{*1}	---	---	ms
t5	70	---	---	ms
t6	0	---	---	ms
t7	0	---	---	
t8	0	---	---	ms

Note:

- (1) T4=0 : concern for residual pattern before BLU turn off.
- (2) T6 : voltage of VDD must decay smoothly after power-off. (customer system decide this value)

4. Optical Specification

Optical characteristics are determined after the unit has been 'ON' and stable for approximately 45 minutes in a dark environment at 25°C. The values specified are at an approximate distance 50cm from the LCD surface at a viewing angle of φ and θ equal to 0°.

Fig.1 presents additional information concerning the measurement equipment and method.

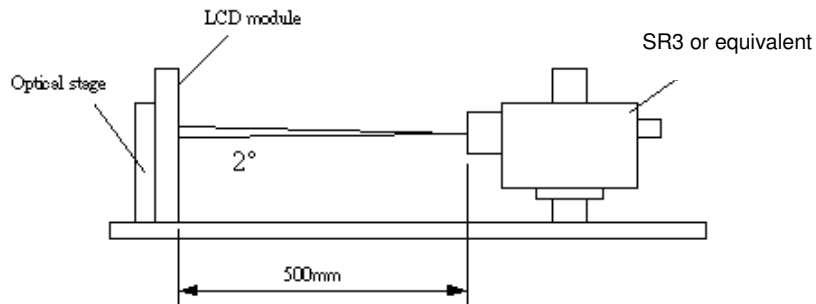

Parameter	Symbol	Values			Unit	Notes
		Min.	Typ.	Max		
Contrast Ratio	CR	4,000	5,000	--		1, 2
Surface Luminance (White)	L_{WH}	360	450	--	cd/m ²	1, 3
Luminance Variation	$\delta_{WHITE(\theta P)}$	--	--	1.3		1, 4
Response Time (G to G)	T_Y	--	5.5	--	Ms	1, 5
Color Gamut	NTSC		72		%	1
Color Coordinates						
Red	R_X	Typ.-0.03	0.64	Typ.+0.03		1
	R_Y		0.33			1
Green	G_X		0.29			1
	G_Y		0.60			1
Blue	B_X		0.15			1
	B_Y		0.06			1
White	W_X		0.28			1
	W_Y		0.29			1
Viewing Angle						
x axis, right($\varphi=0^\circ$)	θ_r	--	89	--	degree	6
x axis, left($\varphi=180^\circ$)	θ_l	--	89	--	degree	
y axis, up($\varphi=90^\circ$)	θ_u	--	89	--	degree	
y axis, down ($\varphi=270^\circ$)	θ_d	--	89	--	degree	

Note:

1. The measured optical data is based on AUO T645HW02 V1 BLU unit.

2. Contrast Ratio (CR) is defined mathematically as:

$$\text{Contrast Ratio} = \frac{\text{Surface Luminance of } L_{on5}}{\text{Surface Luminance of } L_{off5}}$$

3. Surface luminance is luminance value at point 5 across the LCD surface 50cm from the surface with all pixels displaying white. From more information see FIG 2.

4. The variation in surface luminance, δ_{WHITE} is defined (center of Screen) as:

$$\delta_{WHITE(9P)} = \text{Maximum}(L_{on1}, L_{on2}, \dots, L_{on9}) / \text{Minimum}(L_{on1}, L_{on2}, \dots, L_{on9})$$

5. Response time T_{γ} is the average time required for display transition by switching the input signal for five luminance ratio (0%,25%,50%,75%,100% brightness matrix) and is based on $F_v=60\text{Hz}$ to optimize.

Measured Response Time		Target				
		0%	25%	50%	75%	100%
Start	0%		0% to 25%	0% to 50%	0% to 75%	0% to 100%
	25%	25% to 0%		25% to 50%	25% to 75%	25% to 100%
	50%	50% to 0%	50% to 25%		50% to 75%	50% to 100%
	75%	75% to 0%	75% to 25%	75% to 50%		75% to 100%
	100%	100% to 0%	100% to 25%	100% to 50%	100% to 75%	

6. Viewing angle is the angle at which the contrast ratio is greater than 10. The angles are determined for the horizontal or x axis and the vertical or y axis with respect to the z axis which is normal to the LCD surface. For more information see FIG4.

FIG. 2 Luminance

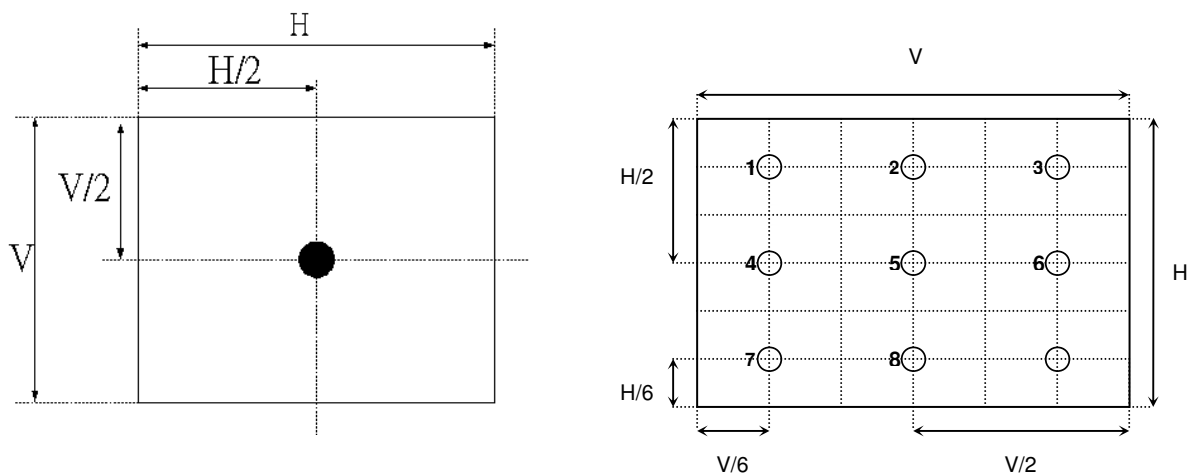
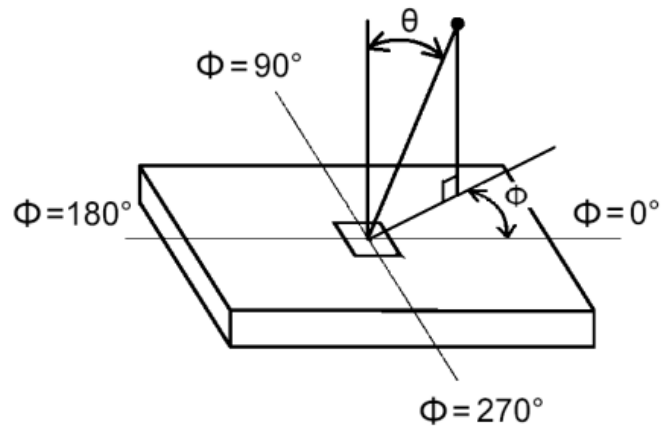
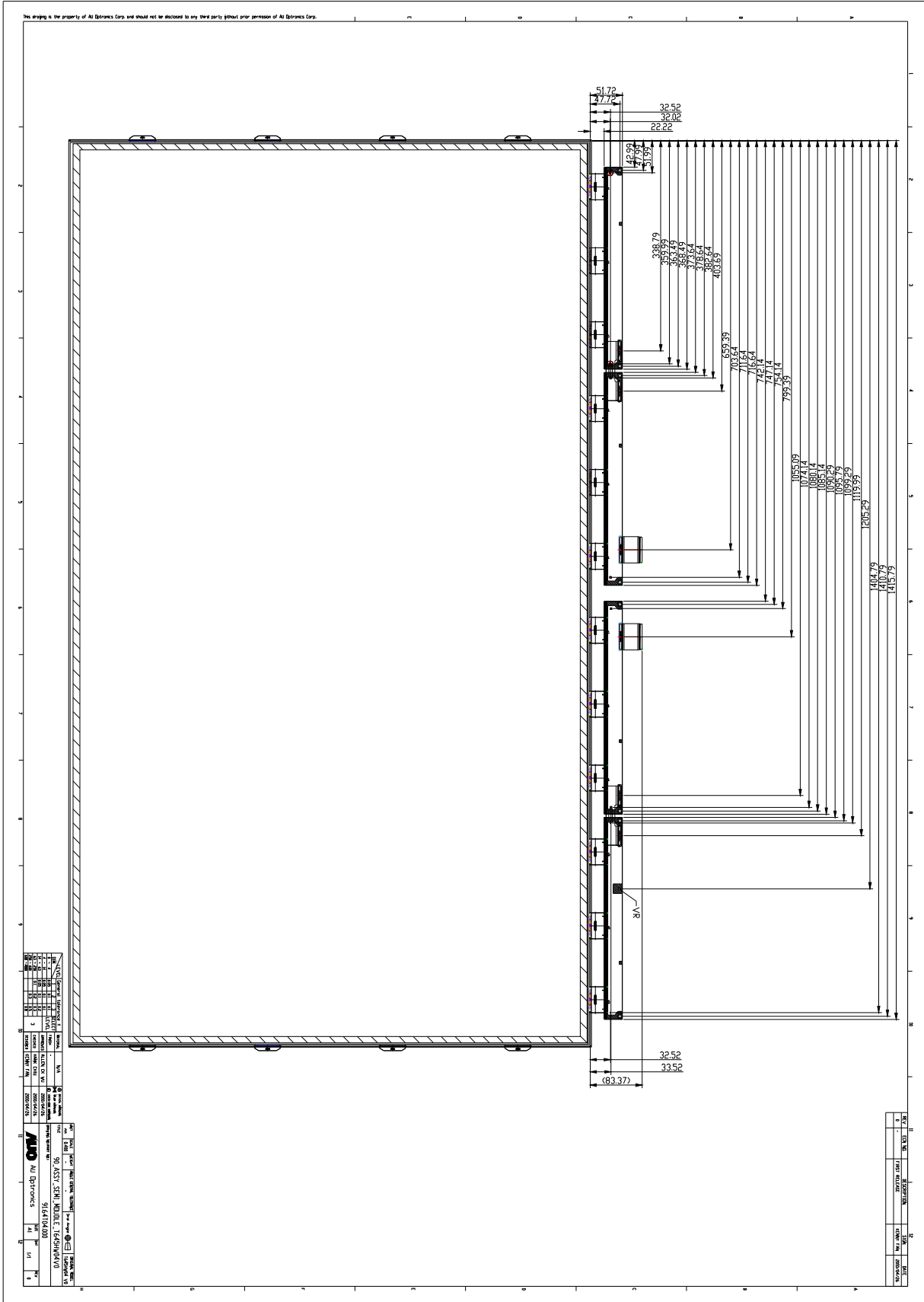

FIG.3 Viewing Angle



Front View



5. Reliability Test Items

	Test Item	Q'ty	Condition
1	High temperature storage test	3	60°C , 300hrs*
2	Low temperature storage test	3	-20°C , 300hrs*
3	High temperature operation test	3	50°C , 300hrs*
4	Low temperature operation test	3	-5°C , 300hrs*
5	Vibration test (With carton)	5	Random wave (1.5G RMS, 10-200Hz) 30mins/ Per each X,Y,Z axes
6	Drop test (With carton)	5	Height: 25.4 cm (ASTMD4169-I) 1 corner,3 edges,6 surfaces (refer ASTM D 5276)

*Reference T645HW02 V2 module for above test items.

6. International Standard

6.1 Safety

- (1) UL 60950-1, UL 60065; Standard for Safety of Information Technology Equipment Including electrical Business Equipment.
- (2) IEC 60950-1 : 2001, IEC 60065:2001 ; Standard for Safety of International Electrotechnical Commission
- (3) EN 60950 : 2001+A11, EN 60065:2002+A1:2006; European Committee for Electrotechnical Standardization (CENELEC), EUROPEAN STANDARD for Safety of Information Technology Equipment Including Electrical Business Equipment.

6.2 EMC

- (1) ANSI C63.4 “Methods of Measurement of Radio-Noise Emissions from Low-Voltage Electrical and Electrical Equipment in the Range of 9kHz to 40GHz. “American National standards Institute(ANSI), 1992
- (2) C.I.S.P.R “Limits and Methods of Measurement of Radio Interface Characteristics of Information Technology Equipment.” International Special committee on Radio Interference.
- (3) EN 55022 “Limits and Methods of Measurement of Radio Interface Characteristics of Information Technology Equipment.” European Committee for Electrotechnical Standardization. (CENELEC), 1998

7. Packing

7-1 Definition of Label :

A. Open cell shipping Label:

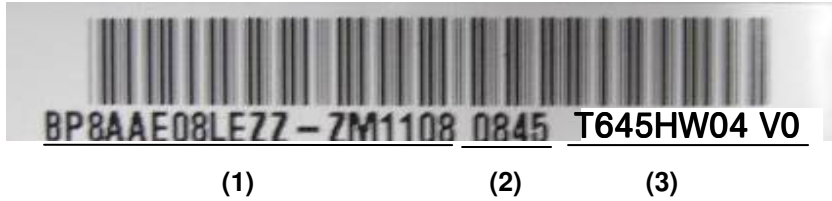

- (1) AUO internal code
- (2) Manufactured date
- (3) Model name



Green mark description

(1) For Pb Free Product, AUO will add  for identification.

(2) For RoHS compatible products, AUO will add  for identification.

Note: The green Mark will be present only when the green documents have been ready by AUO internal green team. (definition of green design follows the AUO green design checklist.)

B. Carton Label:

AU Optronics	QTY : 5		
MODEL NO: T645HW04 V0			
PART NO: 91.64T04.XXX			
CUSTOMER NO:			
CARTON NO:			
Made in XXXXXX	*XXXXXX-XXXXXXXXXX*		

7-2 Packing Methods:

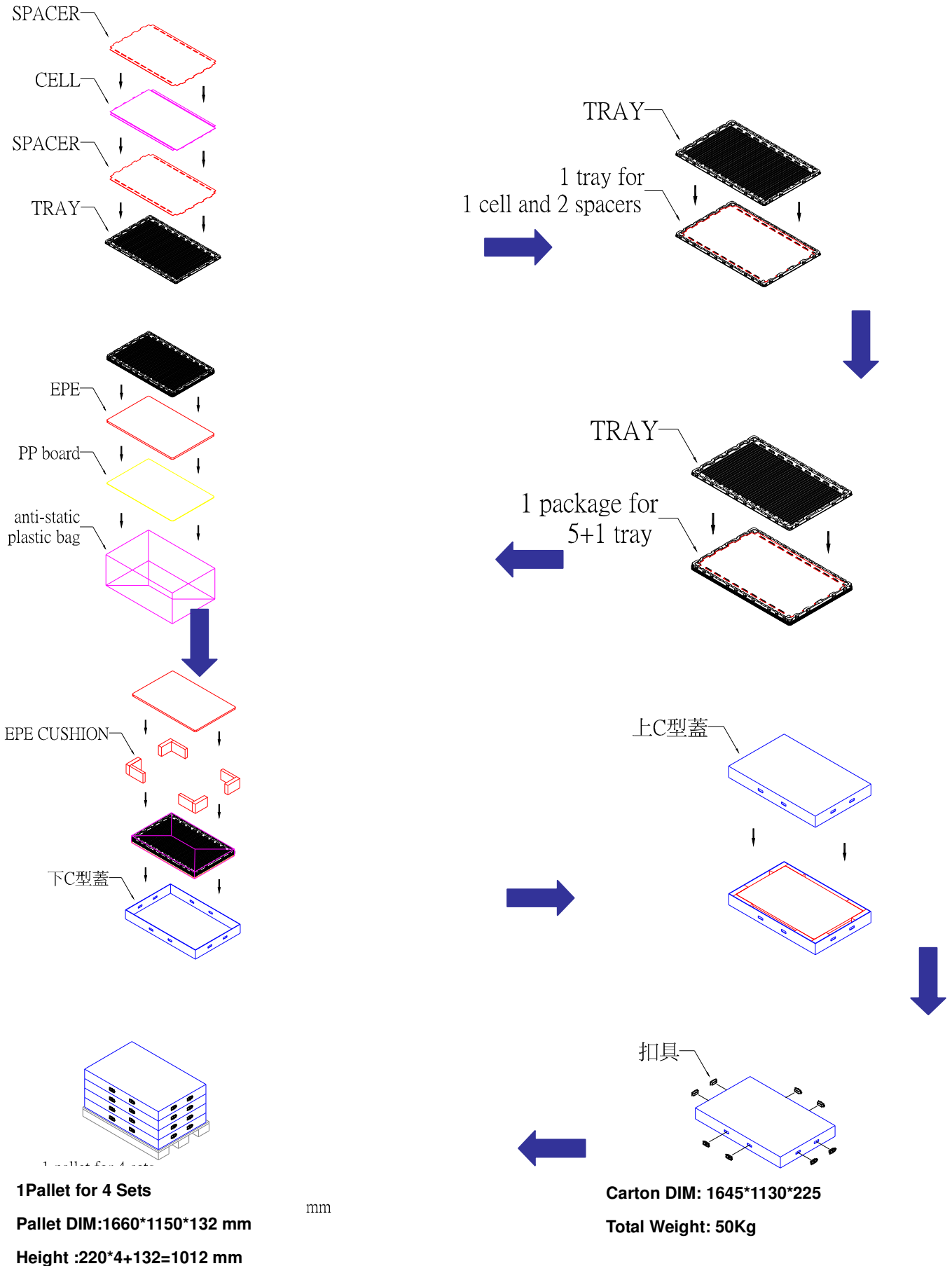

7-3 Pallet and Shipment Information

	Item	Specification			Packing Remark
		Qty.	Dimension	Weight (kg)	
1	Packing Box	5 pcs/box	1645(L)mm*1130(W)mm*225(H)mm	50	
2	Pallet	1	1660(L)mm*1150(W)mm*132(H)mm	20	
3	Boxes per Pallet	4 boxes/Pallet (By Air) ; 4 Boxes/Pallet*Double Pallet (By Sea)			
4	Panels per Pallet	20 pcs/pallet(By Air) ; 20 pcs/Pallet*Double Pallet (By Sea)			
5	Pallet after packing	20(by Air)	1660(L)mm*1150(W)mm*807(H)mm (by Air)	220 (by Air)	
		40(by Sea)	1660(L)mm*1150(W)mm*1614(H)mm (by Sea)	440(by Sea)	40ft DC

Package By Air

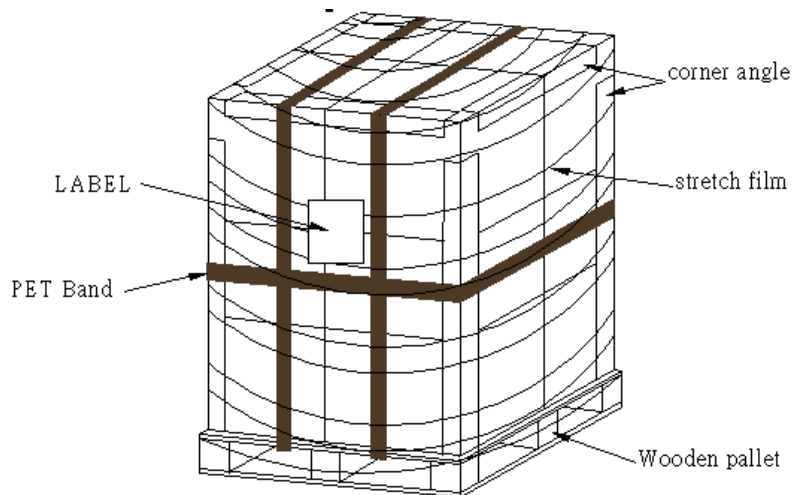

Package by Sea (double pallet)

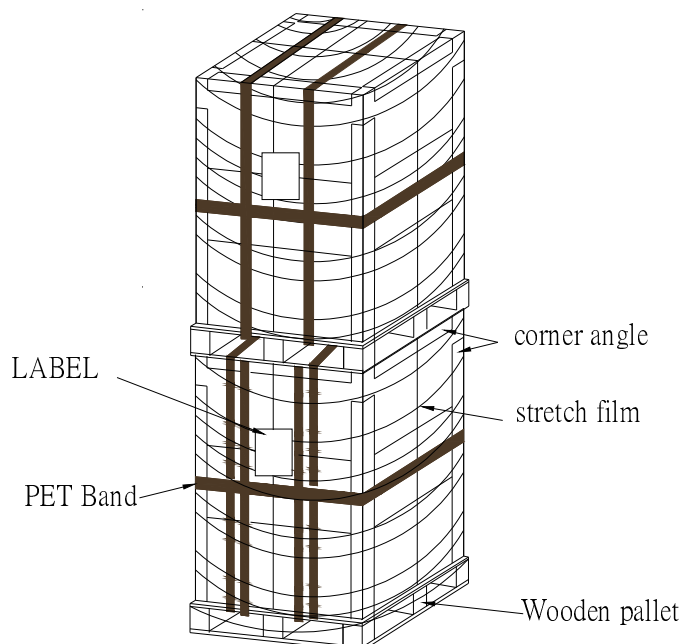

8. PRECAUTIONS

Please pay attention to the followings when you use this TFT LCD module.

8-1 MOUNTING PRECAUTIONS

- (1) You must mount a module using holes arranged in four corners or four sides.
- (2) You should consider the mounting structure so that uneven force (ex. twisted stress) is not applied to module. And the case on which a module is mounted should have sufficient strength so that external force is not transmitted directly to the module.
- (3) Please attach the surface transparent protective plate to the surface in order to protect the polarizer. Transparent protective plate should have sufficient strength in order to resist external force.
- (4) You should adopt radiation structure to satisfy the temperature specification.
- (5) Acetic acid type and chlorine type materials for the cover case are not desirable because the former generates corrosive gas of attacking the polarizer at high temperature and the latter causes circuit broken by electro-chemical reaction.
- (6) Do not touch, push or rub the exposed polarizer with glass, tweezers or anything harder than HB pencil lead. And please do not rub with dust clothes with chemical treatment. Do not touch the surface of polarizer for bare hand or greasy cloth. (Some cosmetics are detrimental to the polarizer.)
- (7) When the surface becomes dusty, please wipe gently with absorbent cotton or other soft materials like chamois soaked with petroleum benzene. Normal-hexane is recommended for cleaning the adhesives used to attach front/ rear polarizer. Do not use acetone, toluene and alcohol because they cause chemical damage to the polarizer.
- (8) Wipe off saliva or water drops as soon as possible. Their long time contact with polarizer causes deformations and color fading.
- (9) Do not open the case because inside circuits do not have sufficient strength.

8-2 OPERATING PRECAUTIONS

- (1) The device listed in the product specification sheets was designed and manufactured for TV application
- (2) The spike noise causes the mis-operation of circuits. It should be lower than following voltage:
 $V = \pm 200\text{mV}$ (Over and under shoot voltage)
- (3) Response time depends on the temperature. (In lower temperature, it becomes longer..)
- (4) Brightness of CCFL depends on the temperature. (In lower temperature, it becomes lower.) And in lower temperature, response time (required time that brightness is stable after turned on) becomes longer.
- (5) Be careful for condensation at sudden temperature change. Condensation makes damage to polarizer or electrical contacted parts. And after fading condensation, smear or spot will occur.
- (6) When fixed patterns are displayed for a long time, remnant image is likely to occur.
- (7) Module has high frequency circuits. Sufficient suppression to the electromagnetic interference shall

be done by system manufacturers. Grounding and shielding methods may be important to minimize the interface.

8-3 ELECTROSTATIC DISCHARGE CONTROL

Since a module is composed of electronic circuits, it is not strong to electrostatic discharge. Make certain that treatment persons are connected to ground through wristband etc. And don't touch interface pin directly.

8-4 PRECAUTIONS FOR STRONG LIGHT EXPOSURE

Strong light exposure causes degradation of polarizer and color filter.

8-5 STORAGE

When storing modules as spares for a long time, the following precautions are necessary.

- (1) Store them in a dark place. Do not expose the module to sunlight or fluorescent light. Keep the temperature between 5°C and 35°C at normal humidity.
- (2) The polarizer surface should not come in contact with any other object. It is recommended that they be stored in the container in which they were shipped.

8-6 HANDLING PRECAUTIONS FOR PROTECTION FILM

- (1) The protection film is attached to the bezel with a small masking tape. When the protection film is peeled off, static electricity is generated between the film and polarizer. This should be peeled off slowly and carefully by people who are electrically grounded and with well ion-blown equipment or in such a condition, etc.
- (2) When the module with protection film attached is stored for a long time, sometimes there remains a very small amount of glue still on the bezel after the protection film is peeled off.
- (3) You can remove the glue easily. When the glue remains on the bezel or its vestige is recognized, please wipe them off with absorbent cotton waste or other soft material like chamois soaked with normal-hexane.