

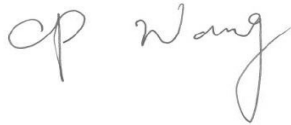



Model Name: T650QVN01.0

Issue Date : 2013/05/30

(*)Final Specifications

Customer Signature	Date	AUO	Date
Approved By		Approval By PM Director CP Wang 	
Note		Reviewed By RD Director Eugene CC Chen 	
		Reviewed By Project Leader Stanley Lo 	
		Prepared By PM Mick Chen 	

Contents

No		
		CONTENTS
0		RECORD OF REVISIONS
1		GENERAL DESCRIPTION
2		ABSOLUTE MAXIMUM RATINGS
3		ELECTRICAL SPECIFICATION
	3-1	ELECTRICAL CHARACTERISTICS
	3-2	INTERFACE CONNECTIONS
	3-3	SIGNAL TIMING SPECIFICATION
	3-4	SIGNAL TIMING WAVEFORM
	3-5	COLOR INPUT DATA REFERENCE
	3-6	POWER SEQUENCE
	3-7	BACKLIGHT SPECIFICATION
4		OPTICAL SPECIFICATION
5		MECHANICAL CHARACTERISTICS
6		RELIABILITY TEST ITEMS
7		INTERNATIONAL STANDARD
	7-1	SAFETY
	7-2	EMC
8		PACKING
	8-1	DEFINITION OF LABEL
	8-2	PACKING METHODS
	8-3	PALLET AND SHIPMENT INFORMATION
9		PRECAUTION
	9-1	MOUNTING PRECAUTIONS
	9-2	OPERATING PRECAUTIONS
	9-3	ELECTROSTATIC DISCHARGE CONTROL
	9-4	PRECAUTIONS FOR STRONG LIGHT EXPOSURE
	9-5	STORAGE
	9-6	HANDLING PRECAUTIONS FOR PROTECT FILM

1. General Description

This specification applies to the 65 inch Color TFT-LCD Module T650QVN01.0. This LCD module has a TFT active matrix type liquid crystal panel 3840x2160 pixels, and diagonal size of 65 inch. This module supports 3840x2160 mode. Each pixel is divided into Red, Green and Blue sub-pixels or dots which are arranged in vertical stripes. Gray scale or the brightness of the sub-pixel color is determined with a 10-bit gray scale signal for each dot.

The T650QVN01.0 has been designed to apply the 10-bit 16 Lanes V by one interface method. It is intended to support displays where high brightness, wide viewing angle, high color saturation, and high color depth are very important.

* General Information

Items	Specification	Unit	Note
Active Screen Size	65	inch	
Display Area	1428.48(H) x 803.52(V)	mm	
Outline Dimension	1454.3(H) x 831.5 (V) x 18(D)	mm	D: front bezel to T-con cover
Driver Element	a-Si TFT active matrix		
Bezel Opening	1434.5 (H) x 809.6 (V)	mm	
Display Colors	10 bit, 16.7M	Colors	
Number of Pixels	3840x2160	Pixel	
Pixel Pitch	0.372 (H) x 0.372(W)	mm	
Pixel Arrangement	RGB vertical stripe		
Display Operation Mode	Normally Black		
Surface Treatment	Glare		
Rotate Function	Unachievable		Note 1
Display Orientation	Signal input with "ABC"		Note 2

Note 1: Rotate Function refers to LCD display could be able to rotate.

Note 2: LCD display as below illustrated when signal input with "ABC".

Rear side

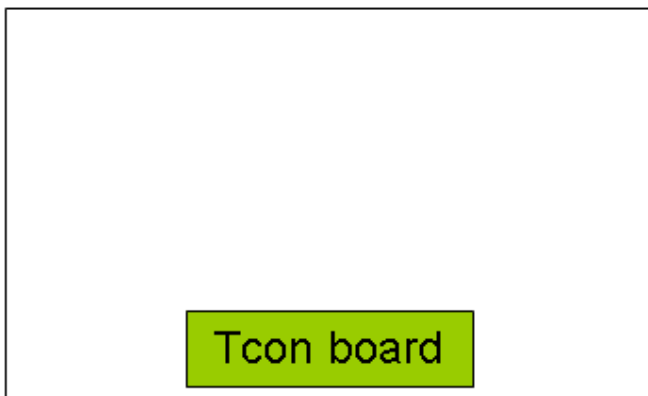

Front side

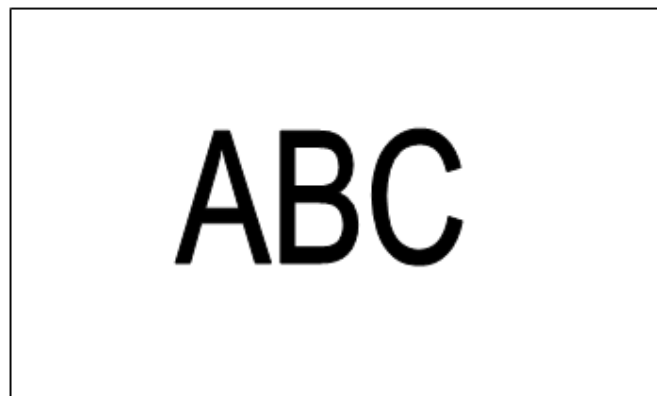

2. Absolute Maximum Ratings

The followings are maximum values which, if exceeded, may cause faulty operation or damage to the unit

Item	Symbol	Min	Max	Unit	Conditions
Logic/LCD Drive Voltage	Vcc	-0.3	14	[Volt]	Note 1
Input Voltage of Signal	Vin	-0.3	3.6	[Volt]	Note 1
Operating Temperature	TOP	0	+50	[°C]	Note 2
Operating Humidity	HOP	10	90	[%RH]	Note 2
Storage Temperature	TST	-20	+60	[°C]	Note 2
Storage Humidity	HST	10	90	[%RH]	Note 2
Panel Surface Temperature	PST		65	[°C]	Note 3

Note 1: Duration:50 msec.

Note 2 : Maximum Wet-Bulb should be 39°C and No condensation.

The relative humidity must not exceed 90% non-condensing at temperatures of 40°C or less. At temperatures greater than 40°C, the wet bulb temperature must not exceed 39°C.

Note 3: Surface temperature is measured at 50°C Dry condition

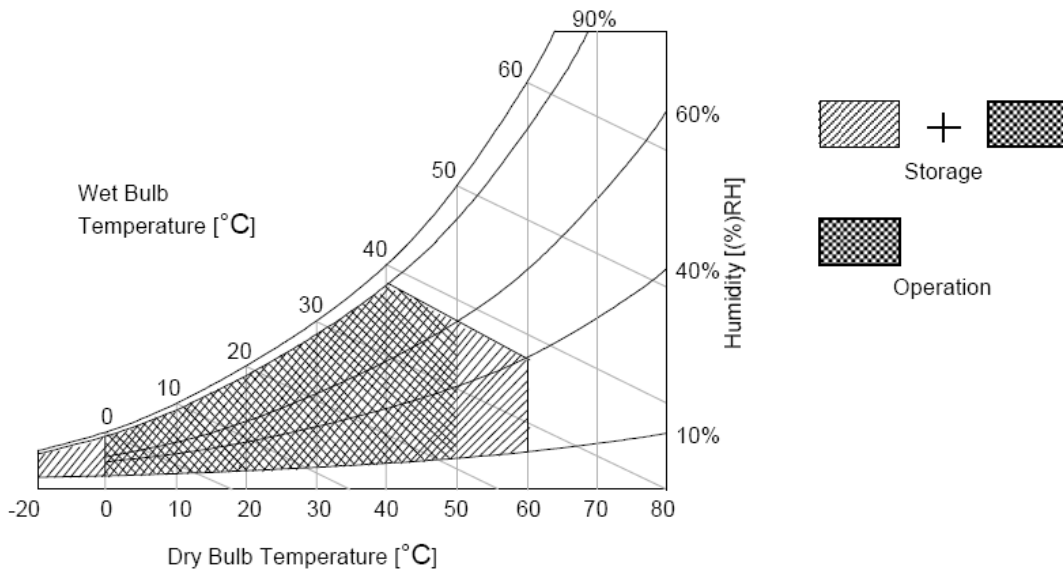

3. Electrical Specification

The T650QVN01.0 has one power inputs, which is employed to power the LCD electronics and to drive the TFT array and liquid crystal.

3.1 Electrical Characteristics

3.1.1: DC Characteristics

Parameter		Symbol	Value			Unit	Note
			Min.	Typ.	Max		
LCD							
Power Supply Input Voltage		V_{DD}	10.8	12	13.2	V_{DC}	
Power Supply Input Current		I_{DD}	--	1.06	3.71	A	1
Power Consumption		P_C	--	13.99	44.52	Watt	1
Inrush Current		I_{RUSH}	--	--	5	A	2
Permissible Ripple of Power Supply Input Voltage		V_{RP}	--	--	$V_{DD} * 5\%$	mV_{pk-pk}	3
V by One Interface	Differential Input High Threshold Voltage	V_{RTH}	+50	--	--	mV_{DC}	4
	Differential Input Low Threshold Voltage	V_{RTL}	--	--	-50	mV_{DC}	4
	Input Common Mode Voltage	V_{RCT}	0.8	0.9	1.0	V_{DC}	4
CMOS Interface	Input High Threshold Voltage	V_{IH} (HIGH)	2.4	--	3.3	V_{DC}	5
	Input Low Threshold Voltage	V_{IL} (LOW)	0	--	0.6	V_{DC}	5
Backlight Power Consumption		P_{BL}		173.6		Watt	
Life time (MTTF)			30000			Hour	6,7

3.1.2: AC Characteristics

Parameter		Symbol	Value			Unit	Note
			Min.	Typ.	Max		
V-by-one Interface	VRXINP/N input each bit Period	T_{RRIP} (UI)	413	--	505	ps	8bit 8
			310	--	379	ps	10bit 8
	CDR lock time(CDR training)	T_{RLCK0}	--	--	1.0	ms	8
	ALN Training	T_{RALN}	--	30720	--	UI	8bit 8
			--	40960	--	UI	10bit 8
	PDX active to hot plug enable	T_{RHPD0}	--	--	1.0	us	8
	Intra-pair skew	T_{INTRA}	--	--	0.3	UI	9
Inter-pair skew	T_{INTER}	--	--	5	UI	10	
I2C Interface	SCL clock frequency	F_{SCL}	0	--	400	KHZ	
	I2C clock high level	T_{SCHi}	0.6	--	--	us	
	I2C clock low level	T_{SCLo}	1.2	--	--	us	
	I2C data setup time	T_{SDS}	100	--	--	ns	
	I2C data hold time	T_{SDH}	0	--	900	ns	
	SDA and SCL rise time	T_R	--	--	1000	ns	
	SDA and SCL fall time	T_F	--	--	300	ns	

Note :

- $V_{DD} = 12.0V$, $F_v = 120Hz$, $F_{clk} = 78.125MHz$, $25\text{ }^\circ C$, Test Pattern : White Pattern
>> refer to "Section:3.3 Signal Timing Specification, Typical timing"
- Measurement condition : Rising time = 400us

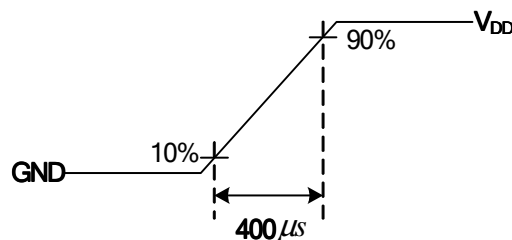

- Test Condition:
 - The measure point of V_{RP} is in LCM side after connecting the System Board and LCM.
 - Under Max. Input current spec. condition.
- $V_{ICM} = 0.82V$

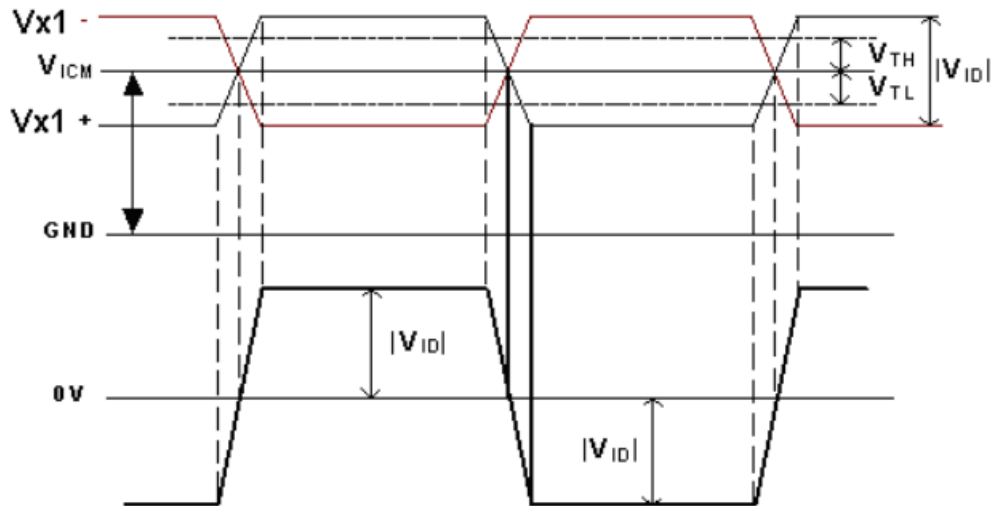

5. The measure points of V_{IH} and V_{IL} are in LCM side after connecting the System Board and LCM.
6. The relative humidity must not exceed 80% non-condensing at temperatures of 40°C or less. At temperatures greater than 40°C , the wet bulb temperature must not exceed 39°C . When operate at low temperatures, the brightness of LED will drop and the life time of LED will be reduced.
7. The lifetime (MTTF) is defined as the time which luminance of LED is 50% compared to its original value. [Operating condition: Continuous operating at $T_a = 25 \pm 2^{\circ}\text{C}$]
8. V-by-one Receiver start up timing waveform

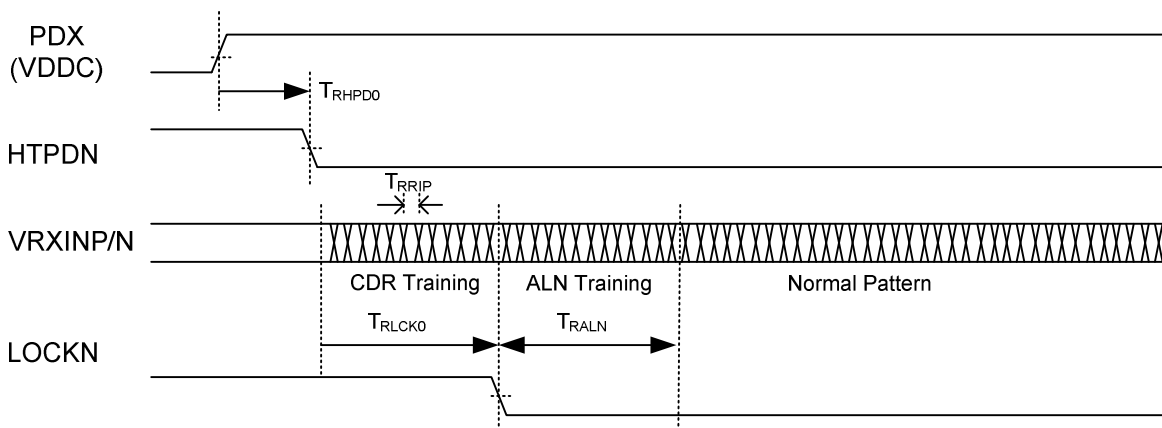

9. V-by-one Intra-pair Skew

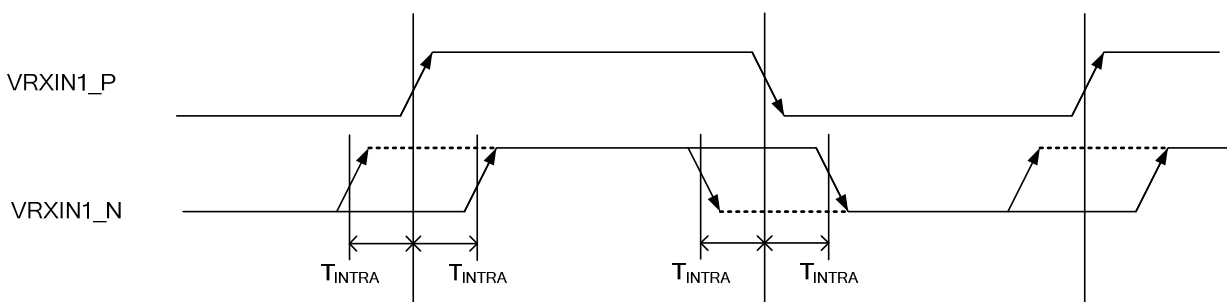

10. V-by-one Inter-pair Skew

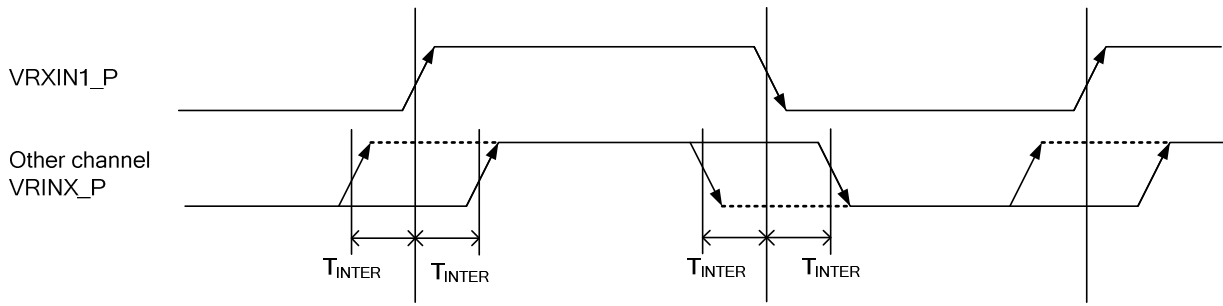

3.2 Interface Connections

- LCD connector: FI-RE51S-HF (JAE, V-by-One 51pin connector)

PIN	Symbol	Description	PIN	Symbol	Description
1	NC	AUO Internal Use Only	26	GND	CML Ground
2	NC	AUO Internal Use Only	27	Rx2n	V-by-One HS Data Lane 2
3	NC	AUO Internal Use Only	28	Rx2p	V-by-One HS Data Lane 2
4	NC	AUO Internal Use Only	29	GND	CML Ground
5	NC	AUO Internal Use Only	30	GND	CML Ground
6	NC	AUO Internal Use Only	31	Rx3n	V-by-One HS Data Lane 3
7	NC	AUO Internal Use Only	32	Rx3p	V-by-One HS Data Lane 3
8	NC	AUO Internal Use Only	33	GND	CML Ground
9	NC	AUO Internal Use Only	34	GND	CML Ground
10	NC	AUO Internal Use Only	35	Rx4n	V-by-One HS Data Lane 4
11	GND	Ground	36	Rx4p	V-by-One HS Data Lane 4
12	GND	Ground	37	GND	CML Ground
13	GND	Ground	38	GND	CML Ground
14	GND	Ground	39	Rx5n	V-by-One HS Data Lane 5
15	GND	Ground	40	Rx5p	V-by-One HS Data Lane 5
16	HTPDN	Hot plug detect	41	GND	CML Ground
17	LOCKN	Lock detect	42	GND	CML Ground
18	GND	CML Ground	43	Rx6n	V-by-One HS Data Lane 6
19	Rx0n	V-by-One HS Data Lane 0	44	Rx6p	V-by-One HS Data Lane 6
20	Rx0p	V-by-One HS Data Lane 0	45	GND	CML Ground
21	GND	CML Ground	46	GND	CML Ground
22	GND	CML Ground	47	Rx7n	V-by-One HS Data Lane 7
23	Rx1n	V-by-One HS Data Lane 1	48	Rx7p	V-by-One HS Data Lane 7
24	Rx1p	V-by-One HS Data Lane 1	49	GND	CML Ground
25	GND	CML Ground	50	NC	AUO Internal Use Only
			51	NC	AUO Internal Use Only

- LCD V-by-One connector: FI-RE41S-HF (JAE, V-by-One 41pin connector)

PIN	Symbol	Description	PIN	Symbol	Description
1	GND	Ground	21	Rx11n	V-by-One HS Data Lane 11
2	GND	Ground	22	Rx11p	V-by-One HS Data Lane 11
3	GND	Ground	23	GND	CML Ground
4	GND	Ground	24	GND	CML Ground
5	GND	Ground	25	Rx12n	V-by-One HS Data Lane 12
6	NC	AUO Internal Use Only	26	Rx12p	V-by-One HS Data Lane 12
7	NC	AUO Internal Use Only	27	GND	CML Ground
8	GND	CML Ground	28	GND	CML Ground
9	Rx8n	V-by-One HS Data Lane 8	29	Rx13n	V-by-One HS Data Lane 13
10	Rx8p	V-by-One HS Data Lane 8	30	Rx13p	V-by-One HS Data Lane 13
11	GND	CML Ground	31	GND	CML Ground
12	GND	CML Ground	32	GND	CML Ground
13	Rx9n	V-by-One HS Data Lane 9	33	Rx14n	V-by-One HS Data Lane 14
14	Rx9p	V-by-One HS Data Lane 9	34	Rx14p	V-by-One HS Data Lane 14
15	GND	CML Ground	35	GND	CML Ground
16	GND	CML Ground	36	GND	CML Ground
17	Rx10n	V-by-One HS Data Lane 10	37	Rx15n	V-by-One HS Data Lane 15
18	Rx10p	V-by-One HS Data Lane 10	38	Rx15p	V-by-One HS Data Lane 15
19	GND	CML Ground	39	GND	CML Ground
20	GND	CML Ground	40	NC	AUO Internal Use Only
			41	NC	AUO Internal Use Only

- LCD Power connector:

Power CN(12pin) : SM12B-PASS-TBT (JST)

PI N	Symbol	Description
1	PWR Power 12V IN	PWR Power 12V IN
2	PWR Power 12V IN	PWR Power 12V IN
3	PWR Power 12V IN	PWR Power 12V IN
4	PWR Power 12V IN	PWR Power 12V IN
5	PWR Power 12V IN	PWR Power 12V IN
6	NC	NC Pin
7	NC	NC Pin
8	GND	Ground
9	GND	Ground
10	GND	Ground
11	GND	Ground
12	GND	Ground

4K2K Input Data Format :
2D mode

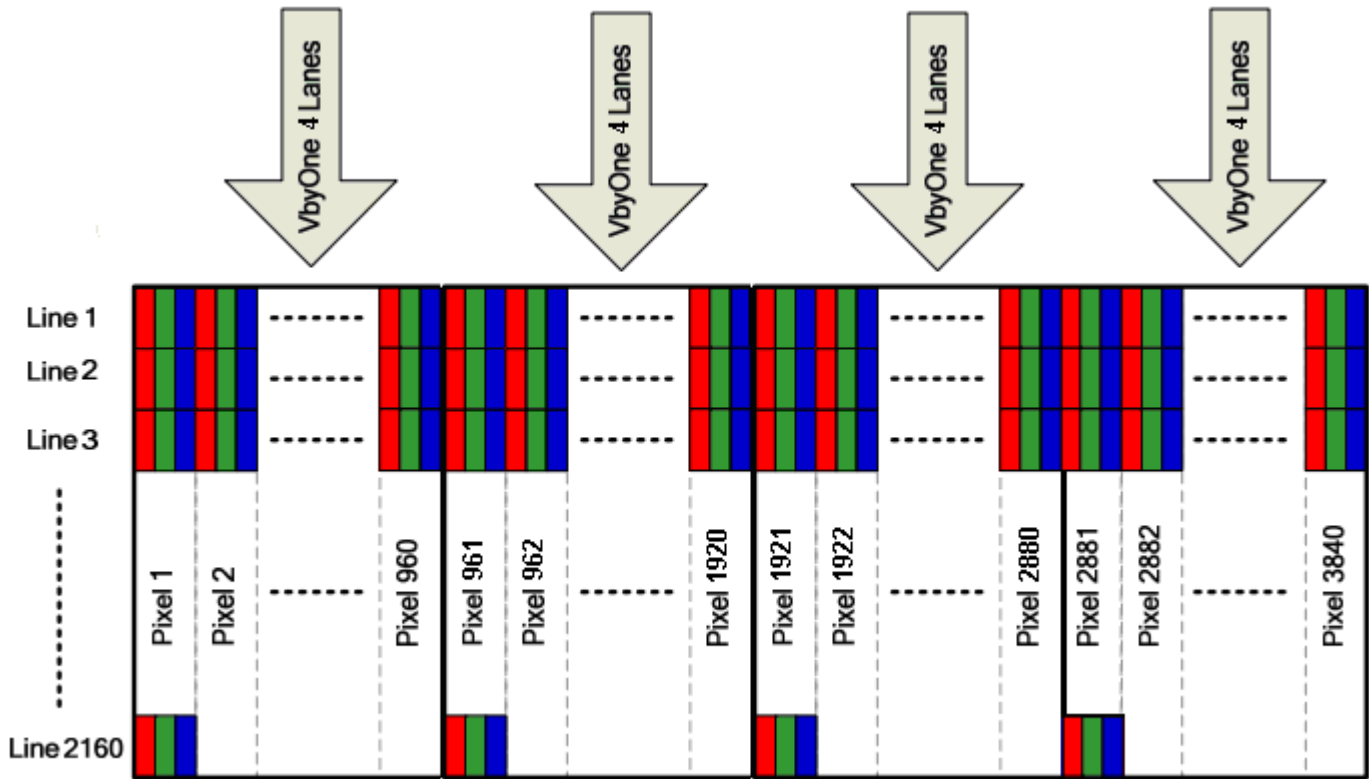

Note: Normal pixel data mapping

2D Mode Pixel Mapping:

Pixel No	Pixel 1			Pixel 2			Pixel 3			~	Pixel 3840			
Line 1	R1	G1	B1	R2	G2	B2	R3	G3	B3	R4	~	R3840	G3840	B3840
Line 2	R1	G1	B1	R2	G2	B2	R3	G3	B3	R4	~	R3840	G3840	B3840
Line 3	R1	G1	B1	R2	G2	B2	R3	G3	B3	R4	~	R3840	G3840	B3840
Line 4	R1	G1	B1	R2	G2	B2	R3	G3	B3	R4	~	R3840	G3840	B3840
Line 5	R1	G1	B1	R2	G2	B2	R3	G3	B3	R4	~	R3840	G3840	B3840
Line 6	R1	G1	B1	R2	G2	B2	R3	G3	B3	R4	~	R3840	G3840	B3840
:	:	:	:	:	:	:	:	:	:	:	~	:	:	:
Line 2158	R1	G1	B1	R2	G2	B2	R3	G3	B3	R4	~	R3840	G3840	B3840
Line 2159	R1	G1	B1	R2	G2	B2	R3	G3	B3	R4	~	R3840	G3840	B3840
Line 2160	R1	G1	B1	R2	G2	B2	R3	G3	B3	R4	~	R3840	G3840	B3840

3.3 Signal Timing Specification

This is the signal timing required at the input of the user connector. All of the interface signal timing should be satisfied with the following specifications for its proper operation.

Timing Table (DE only Mode)

Signal	Item	Symbol	Min.	Typ.	Max	Unit
Vertical Section	Period	Tv	2180	2200	2692	Th
	Active	Tdisp (v)	2160			Th
	Blanking	Tblk (v)	20	40	532	Th
Horizontal Section	Period	Th	280	290	354	Tclk
	Active	Tdisp (h)	240			Tclk
	Blanking	Tblk (h)	40	50	114	Tclk
Clock	Frequency	Fclk=1/Tclk	66	76.56	78.125	MHz
Vertical Frequency	Frequency	Fv	98	120	122	Hz
Horizontal Frequency	Frequency	Fh	240	264	278.4	KHz

Notes:

- (1) Display position is specific by the rise of DE signal only.
Horizontal display position is specified by the rising edge of 1st DCLK after the rise of 1st DE, is displayed on the left edge of the screen.
- (2) Vertical display position is specified by the rise of DE after a "Low" level period equivalent to eight times of horizontal period. The 1st data corresponding to one horizontal line after the rise of 1st DE is displayed at the top line of screen.
- (3) If a period of DE "High" is less than 3840 DCLK or less than 2160 lines, the rest of the screen displays black.
- (4) The display position does not fit to the screen if a period of DE "High" and the effective data period do not synchronize with each other.
- (5) Under 3D mode, signal should be input as following sequence: 1st line: right eye, 2nd line: left eye (when rotate function is not implemented and Tcon position is at panel upper side).



3.4 Signal Timing Waveforms

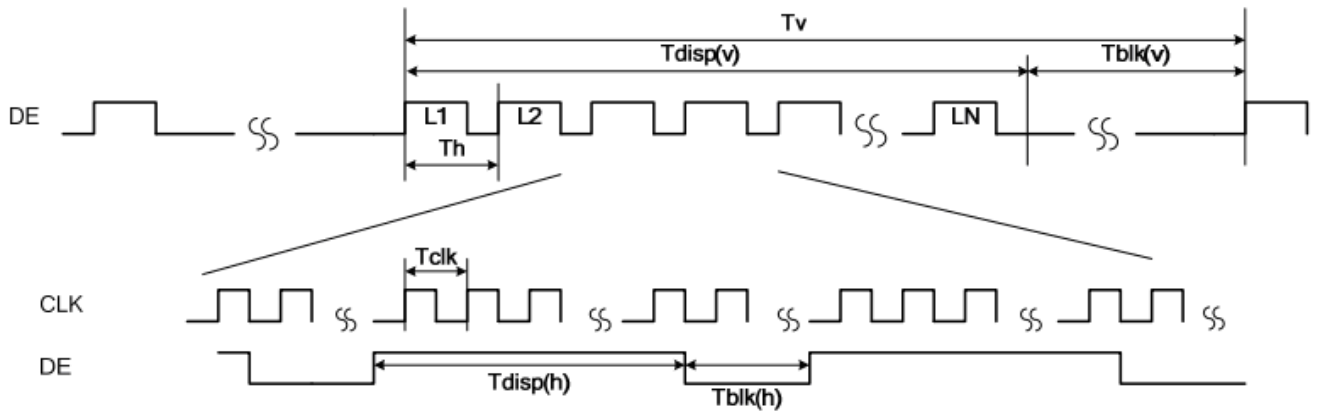

Single Lane
V-by-One Pixel Data

Lane 0		1	5	9	...	957		1	5	9	...	957	
Lane 1		2	6	10	...	958		2	6	10	...	958	
Lane 2		3	7	11	...	959		3	7	11	...	959	
Lane 3		4	8	12	...	960		4	8	12	...	960	

3.6 Power Sequence for LCD

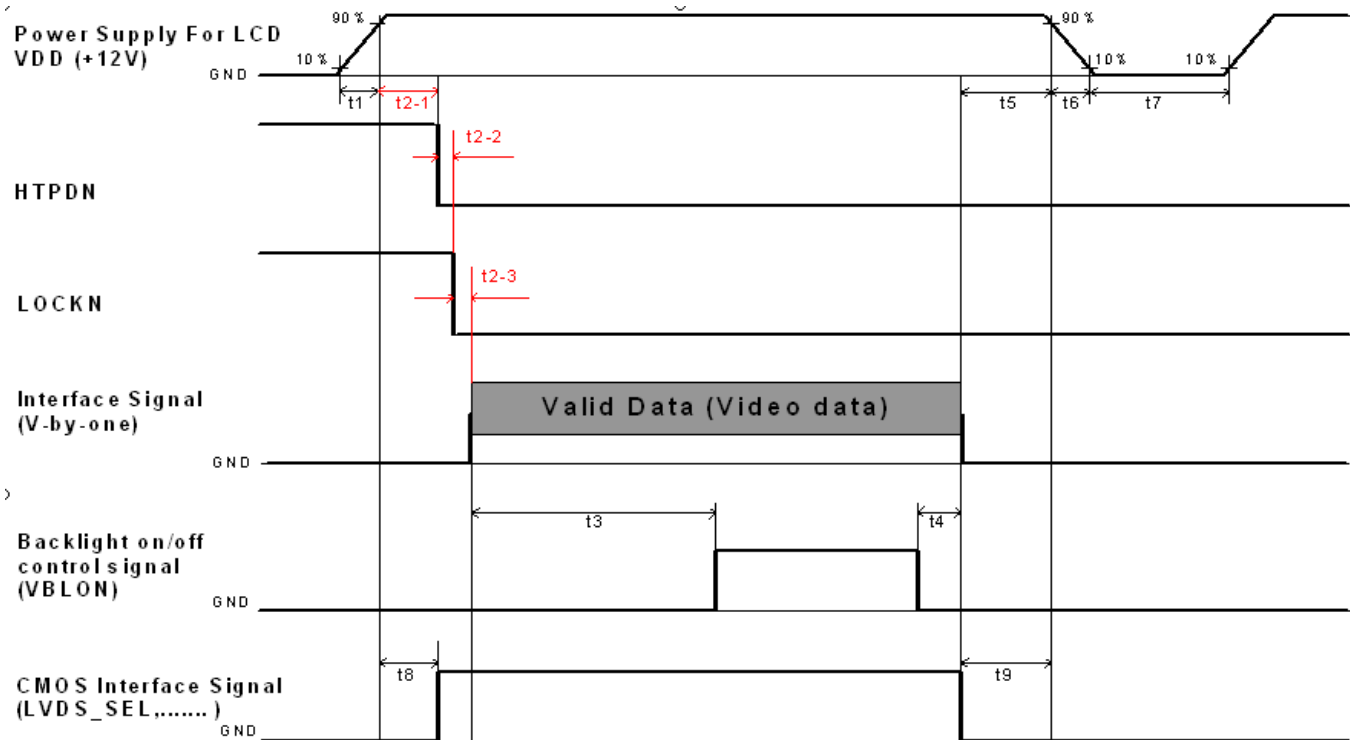

Parameter	Values			Unit
	Min.	Type.	Max.	
t1	0.4	---	30	ms
t2-1	150	---	200	ms
t2-2	---	---	---*1	ms
t2-3	---	---	1	ms
t3	450	---	---	ms
t4	0*2	---	---	ms
t5	0	---	---	ms
t6	---	---	---*3	ms
t7	500	---	---	ms
t8	10*4	---	50	ms
t9	0	---	---	ms

Note:

(1) t2-2 : V by One training time after power-on. The timing of HTPDN falling edge to LOCKN falling edge decided by customer system.

(2) t4=0 : concern for residual pattern before BLU turn off.

- (3) t6 : voltage of VDD must decay smoothly after power-off. (customer system decide this value)
- (4) When CMOS Interface signal is N.C. (no connection), opened in Transmitted end, t8 timing spec can be negligible.
- (5) t2-1: VDD rising(90%) to HTPDN falling edge
 - t2-2: CDR lock time (CDR training)
 - t2-3: ALN training
- (6) LVDS_SEL function is not available.

3.7 Backlight Specification (independent driver board)

The backlight unit contains 8 pcs light bar.

3.7.1 Light bar Driven Condition

No	Item	Symbol	Condition						Description	Specification				Note	
			Vin (volt)			PDIM (%)	Temperature (°C)			Min	Typ	Max	unit		
			Min	Typ	Max	Typ	Min	Typ							Max
1	Input voltage	Vin				100	-	25	-	DC input voltage Vin_typ ±10%	21.6	24	26.4	Volt	
2	Input current	Iin	-	24	-	100	-	25	-	Input current of 100% brightness Iin_typ ±5%		TBD	TBD	A	
3	Input inrush current	Irush	21.6	24	26.4	100	-	25	-	Input inrush current	-	-	TBD	A	
3	Input voltage protection	IVP	-	-	-	-	-	25	-	Input Protection voltage is Vintyp	17	-	20	Volt	
											Recover voltage				
4	External PWM dimming duty ratio and voltage (PDIM Pin)	Dpwm	21.6	24	26.4	-	-	25		E_PWM duty ratio of Max brightness	-	100	-	%	
		Dpwm	21.6	24	26.4	-	-	25		E_PWM duty ratio of Min brightness	-	0	-	%	*1
		Vburst	21.6	24	26.4	-	-	25		E_PWM voltage of Low (off) level	-0.3	-	0.8	Volt	
		Vburst	21.6	24	26.4	-	-	25		E_PWM voltage of High (on) level	2	-	3.3	Volt	
		Fpwm	21.6	24	26.4	-	-	25		E_PWM frequency	90	-	240	Hz	
5	On/Off control voltage	VBLON	21.6	24	26.4	-	-	25	-	VBLON voltage of Low level (Enable Off)	-0.3	-	0.8	Volt	
		VBLON	21.6	24	26.4	-	-	25	-	VBLON voltage of High level, or pin open (Enable On)	2	-	3.3	Volt	
6	Output operating voltage	Vo	21.6	24	26.4	100	-	25	-	Output operating voltage: Vo Vo= LED/String*LED Vf(min, typ,max).	58	65	70	Volt	*2
7	Output current	Iomax	21.6	24	26.4	100	-	25	-	Output current of Max brightness for one channel Iorange=Iotyp +/- 5%	109.25	115	120.75	mA	
8	Output Current ripple	Iorp	21.6	24	26.4	100	-	25	-	Output Current ripple Iop-p/Iorms	-	-	10	%	
9	Delta Vf	Iorp	21.6	24	26.4	100	-	25	-	Max delta Vf of LED string It's depended on LED binning.	-	-	1.8	V	
10	Operation temperature	Top	-	24	-	-	-	-	-	Room temp of Driving board operation	-10	25	70	°C	
11	Storage temperature	Tst	-	24	-	-	-	-	-	Driving board PCBA is put in chamber	-30	-	80	°C	

Note :

*1. IF External PWM function includes 5% dimming function. Judge condition is shown below:

- 1.) Backlight module must be lighted ON normally.
- 2.) All protection function must operate normally.
- 3.) Uniformity and flicker could NOT be guaranteed!

*2. LED/String=1pcs, LED Vf(min, typ,max)=**5.8V, 6.5V, 7V**

3.7.2 Input Pin Assignment

CN1: CI0114M1HRL-NH (Cvilux) or compatible

Pin No	Symbol	Description
1	VDDDB	Operating Voltage Supply, +24V DC regulated
2	VDDDB	Operating Voltage Supply, +24V DC regulated
3	VDDDB	Operating Voltage Supply, +24V DC regulated
4	VDDDB	Operating Voltage Supply, +24V DC regulated
5	VDDDB	Operating Voltage Supply, +24V DC regulated
6	BLGND	Ground and Current Return
7	BLGND	Ground and Current Return
8	BLGND	Ground and Current Return
9	BLGND	Ground and Current Return
10	BLGND	Ground and Current Return
11	DET	BLU status detection: Normal : 0~0.8V ; Abnormal : Open collector (Recommend Pull high R > 10K, VDD = 3.3V)
12	VBLON	BL On-Off: High/Open (2.0V~5.5V) for BL On , Low (GND) for off
13	NC	NA
14	External PWM(PDIM) (*)	External PWM (0%~100%)

(Note*)

PWM Dimming range:



IF External PWM function less than 5% dimming ratio, Judge condition as below:

- (1) Backlight module must be lighted ON normally.
- (2) All protection function must work normally.
- (3) Uniformity and flicker could NOT be guaranteed

CN2: CI0112M1HRL-NH (Cvilux) or compatible

Pin No	Symbol	Description
1	1	VDDDB
2	2	VDDDB
3	3	VDDDB
4	4	VDDDB
5	5	VDDDB
6	6	BLGND
7	7	BLGND
8	8	BLGND
9	9	BLGND
10	10	BLGND
11	NC	NA
12	NC	NA

3.7.3 Power Sequence for Backlight

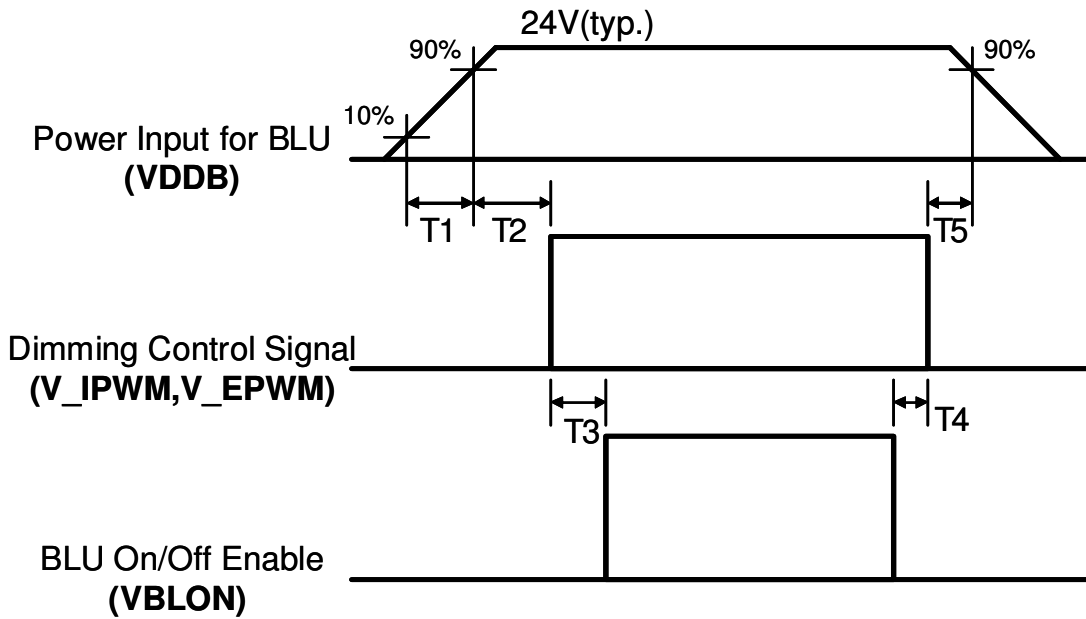

Dip condition for Inverter

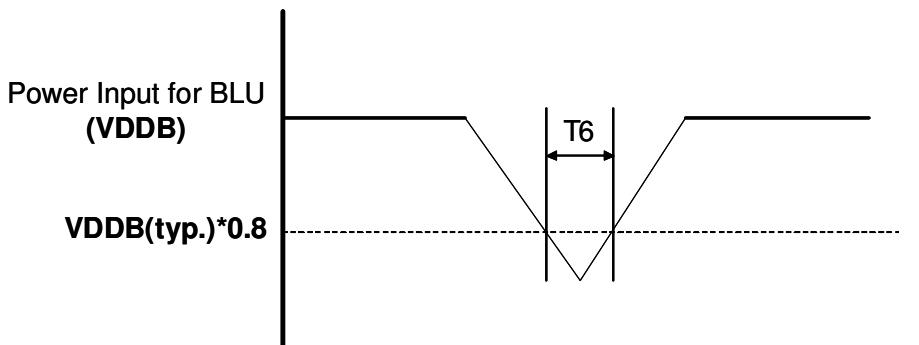

Parameter	Value			Units
	Min	Typ	Max	
T1	20	-	-	ms
T2	500	-	-	ms
T3	250	-	-	ms
T4	0	-	-	ms
T5	1	-	-	ms
T6	-	-	10	ms

4. Optical Specification

Optical characteristics are determined after the unit has been 'ON' and stable for approximately 45 minutes in a dark environment at 25°C. The values specified are at an approximate distance 50cm from the LCD surface at a viewing angle of ϕ and θ equal to 0°.

Fig.1 presents additional information concerning the measurement equipment and method.

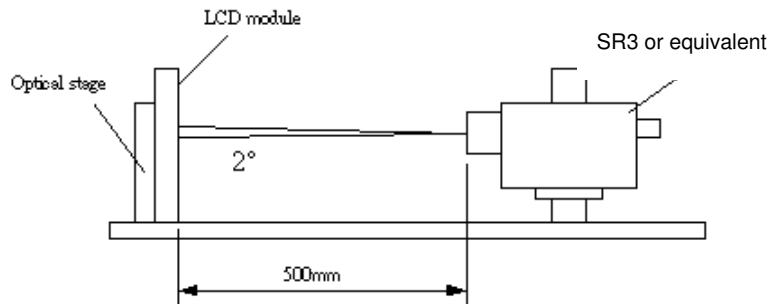

Parameter	Symbol	Values			Unit	Notes				
		Min.	Typ.	Max						
Contrast Ratio	CR	3200	4000	--		1				
Surface Luminance (White)	L_{WH}	280	350	--	cd/m ²	2				
Luminance Variation	$\delta_{WHITE(\theta P)}$	--	--	1.33		3				
Response Time (G to G)	T_{γ}	--	6.5	--	Ms	4				
Color Gamut	NTSC		72		%					
Color Coordinates										
Red	R_x	Typ.-0.03	0.630	Typ.+0.03						
	R_y		0.340							
Green	G_x		0.340							
	G_y		0.620							
Blue	B_x		0.150							
	B_y		0.040							
White	W_x		0.280							
	W_y		0.290							
Viewing Angle										
x axis, right($\phi=0^\circ$)	θ_r		--				89	--	degree	5
x axis, left($\phi=180^\circ$)	θ_l	--	89	--	degree					
y axis, up($\phi=90^\circ$)	θ_u	--	89	--	degree					
y axis, down ($\phi=270^\circ$)	θ_d	--	89	--	degree					

Note:

1. Contrast Ratio (CR) is defined mathematically as:

$$\text{Contrast Ratio} = \frac{\text{Surface Luminance of } L_{on5}}{\text{Surface Luminance of } L_{off5}}$$

2. Surface luminance is luminance value at point 5 across the LCD surface 50cm from the surface with all pixels displaying white. From more information see FIG 2. LED current I_F = typical value (without driver board), LED input $V_{DDB} = 24V$, I_{DDB} = Typical value (with driver board), $L_{WH} = L_{on5}$ where L_{on5} is the luminance with all pixels displaying white at center 5 location.

3. The variation in surface luminance, δ_{WHITE} is defined (center of Screen) as:

$$\delta_{WHITE(9P)} = \frac{\text{Maximum}(L_{on1}, L_{on2}, \dots, L_{on9})}{\text{Minimum}(L_{on1}, L_{on2}, \dots, L_{on9})}$$

4. Response time T_γ is the average time required for display transition by switching the input signal for five luminance ratio (0%,25%,50%,75%,100% brightness matrix) and is based on $F_v = 120Hz$ to optimize.

Measured Response Time		Target				
		0%	25%	50%	75%	100%
Start	0%		0% to 25%	0% to 50%	0% to 75%	0% to 100%
	25%	25% to 0%		25% to 50%	25% to 75%	25% to 100%
	50%	50% to 0%	50% to 25%		50% to 75%	50% to 100%
	75%	75% to 0%	75% to 25%	75% to 50%		75% to 100%
	100%	100% to 0%	100% to 25%	100% to 50%	100% to 75%	

T_γ is determined by 10% to 90% brightness difference of rising or falling period. (As illustrated)

The response time is defined as the following figure and shall be measured by switching the input signal for “any level of gray(bright) “ and “any level of gray(dark)”.

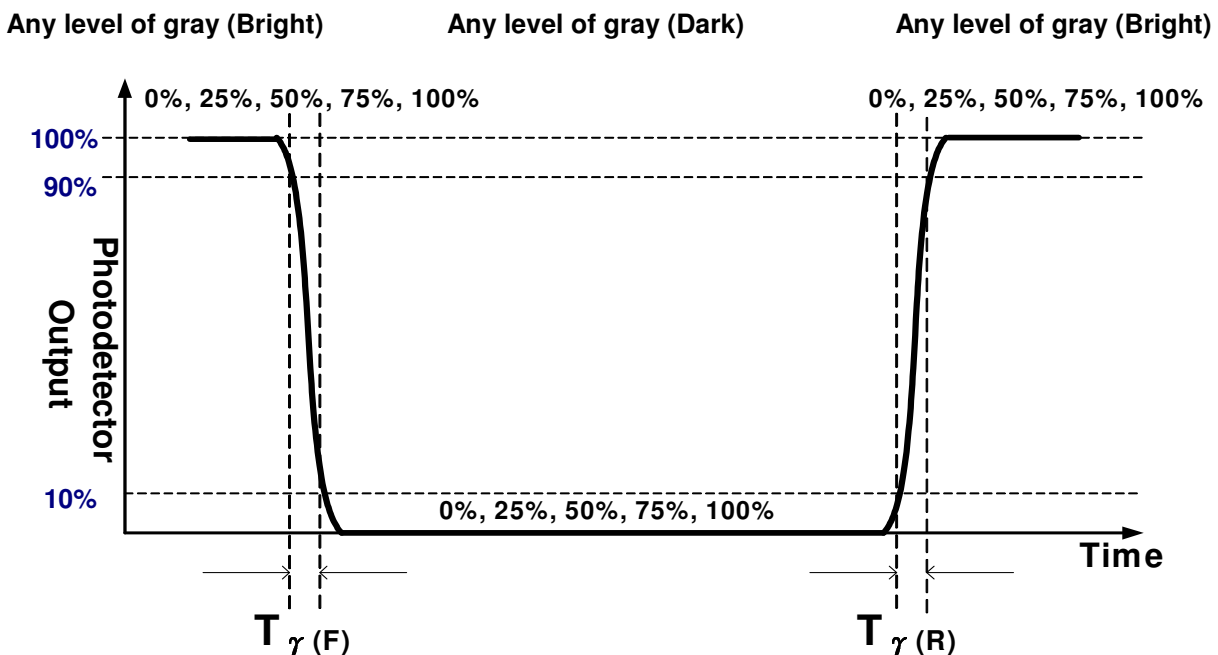
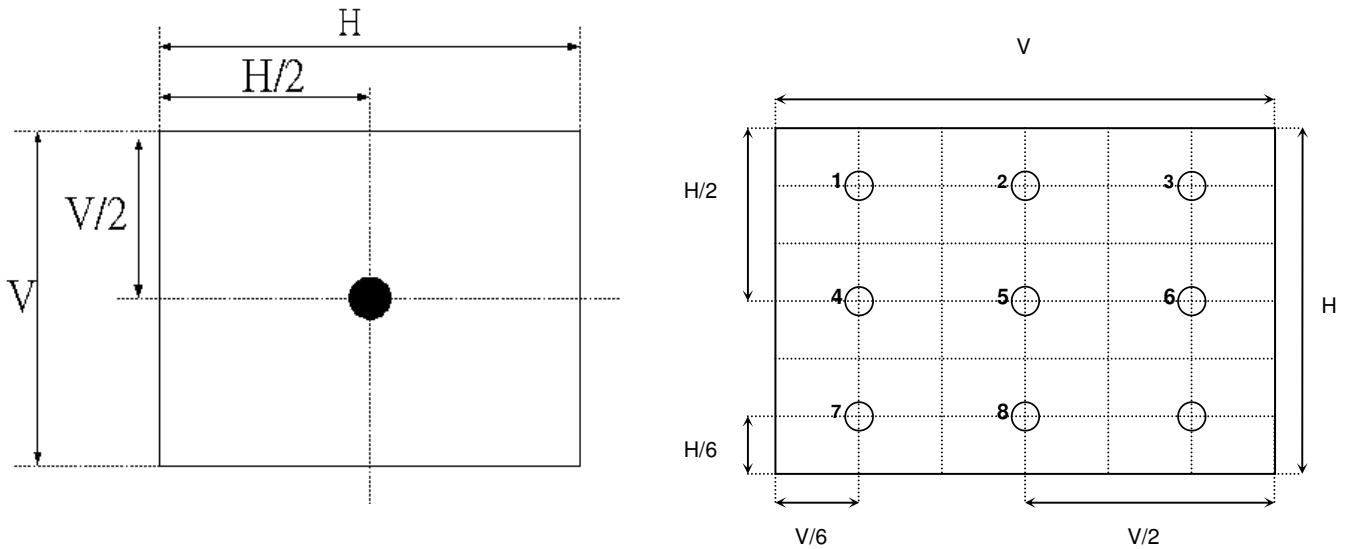
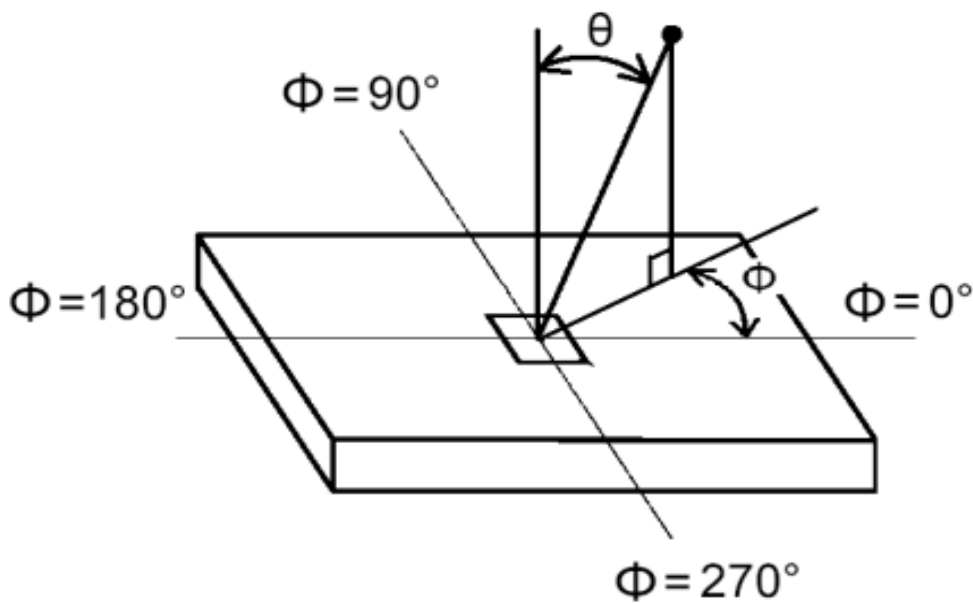

FIG. 2 Luminance



5. Viewing angle is the angle at which the contrast ratio is greater than 10. The angles are determined for the horizontal or x axis and the vertical or y axis with respect to the z axis which is normal to the LCD surface. For more information see FIG3.

FIG.3 Viewing Angle



5. Mechanical Characteristics

The contents provide general mechanical characteristics for the model T650QVN01.0. In addition the figures in the next page are detailed mechanical drawing of the LCD.

Item	Dimension	Unit	Note	
Outline Dimension	Horizontal	1454.3	mm	
	Vertical	831.5	mm	
	Depth (Dmin)	18	mm	front bezel to T-con cover
	Depth (Dmax)	29.3	mm	to T-con cover
Weight	25200	g		

Back View

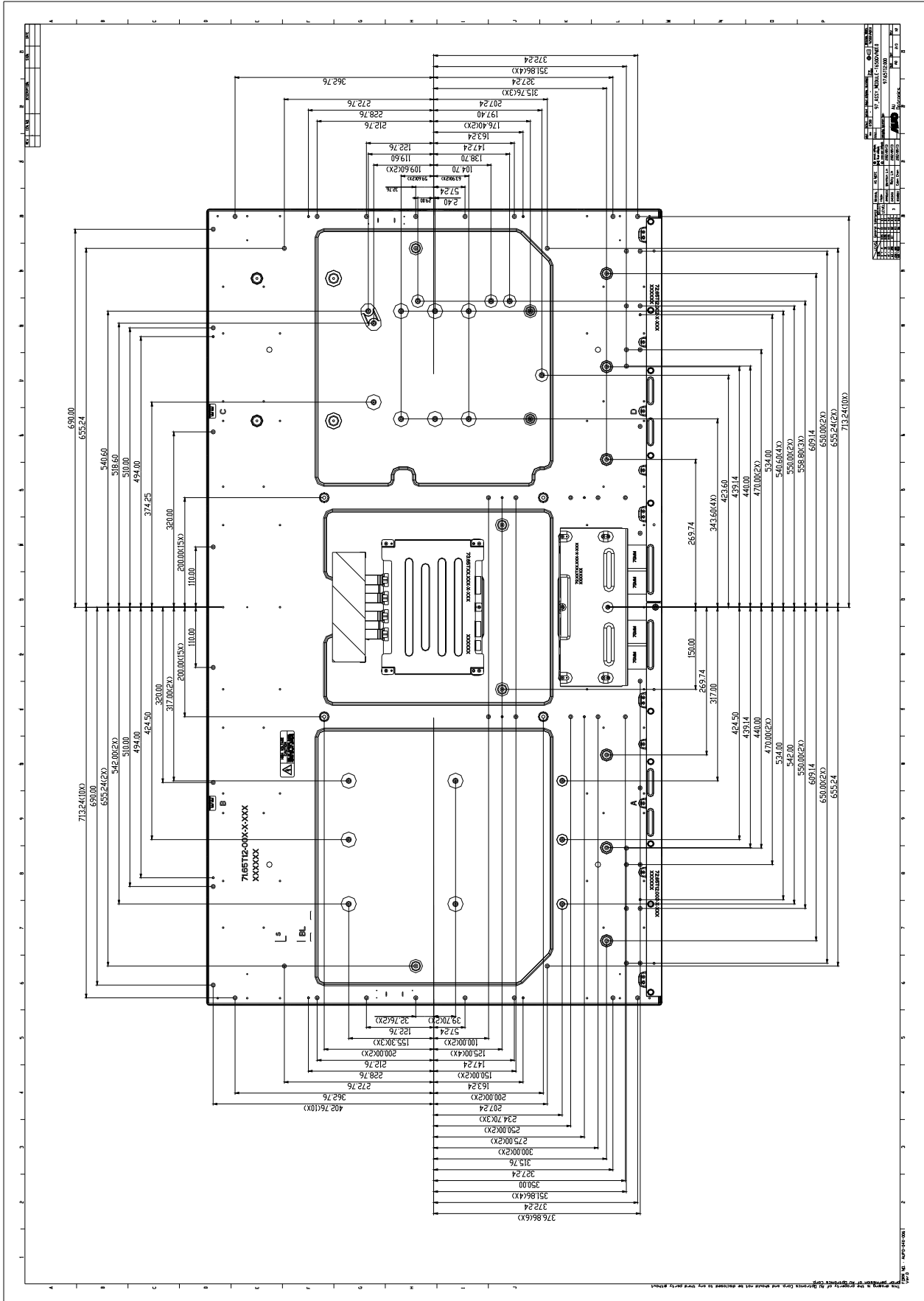

6. Reliability Test Items

	Test Item	Q'ty	Condition
1	High temperature storage test	3	60°C, 300hrs
2	Low temperature storage test	3	-20°C, 300hrs
3	Vibration test (With carton)	5/carton	Random wave (1.05Grms 10~200Hz) Duration : X,Y,Z 10min per axes
4	Drop test (With carton)	5/carton	surround four flats, 150 mm bottom flat two times, 254 mm

7. International Standard

7.1 Safety

- (1) UL 60950-1, UL 60065; Standard for Safety of Information Technology Equipment Including electrical Business Equipment.
- (2) IEC 60950-1 : 2001, IEC 60065:2001 ; Standard for Safety of International Electrotechnical Commission
- (3) EN 60950 : 2001+A11, EN 60065:2002+A1:2006; European Committee for Electrotechnical Standardization (CENELEC), EUROPEAN STANDARD for Safety of Information Technology Equipment Including Electrical Business Equipment.

7.2 EMC

- (1) ANSI C63.4 "Methods of Measurement of Radio-Noise Emissions from Low-Voltage Electrical and Electrical Equipment in the Range of 9kHz to 40GHz. "American National standards Institute(ANSI), 1992
- (2) C.I.S.P.R "Limits and Methods of Measurement of Radio Interface Characteristics of Information Technology Equipment." International Special committee on Radio Interference.
- (3) EN 55022 "Limits and Methods of Measurement of Radio Interface Characteristics of Information Technology Equipment." European Committee for Electrotechnical Standardization. (CENELEC), 1998

8. Packing

8-1 DEFINITION OF LABEL:

A. Panel Label:

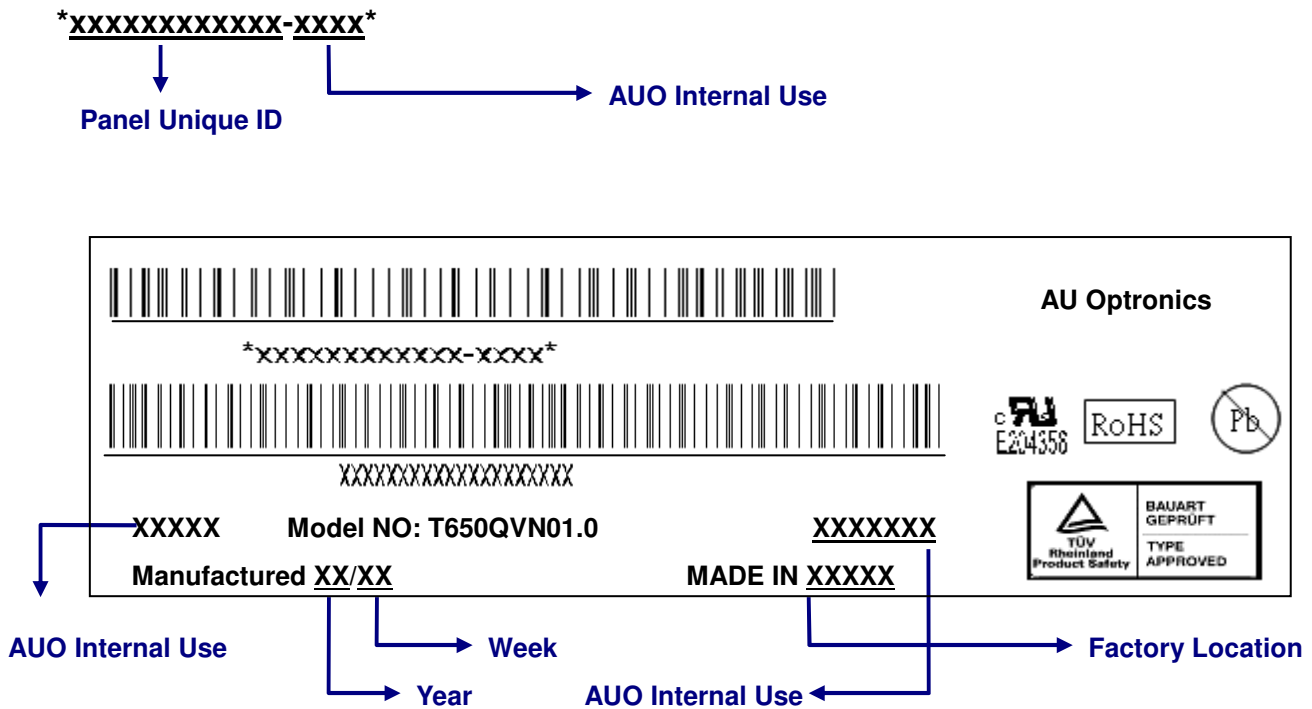

Green mark description

(1) For Pb Free Product, AUO will add  for identification.

(2) For RoHs compatible products, AUO will add  for identification.

Note: The green Mark will be present only when the green documents have been ready by AUO internal green team.
(definition of green design follows the AUO green design checklist.)

B. Carton Label:

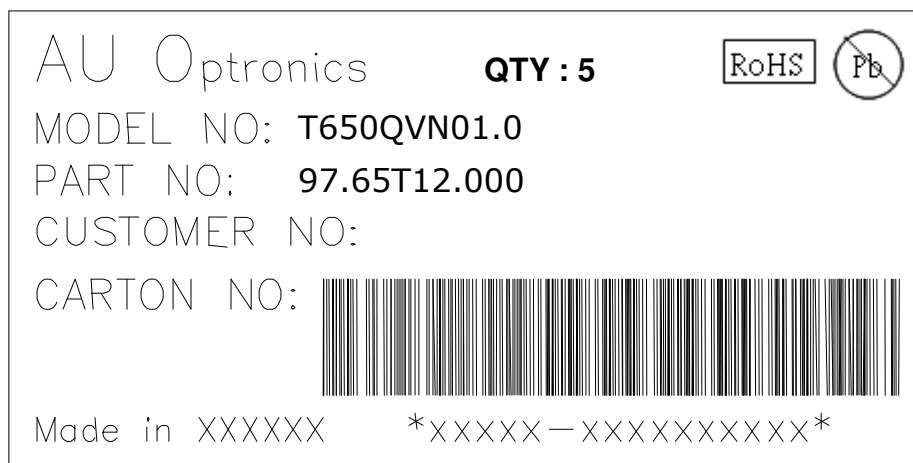

8-2 PACKING METHODS:

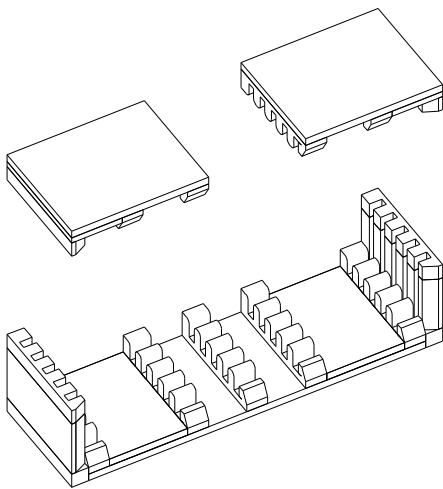
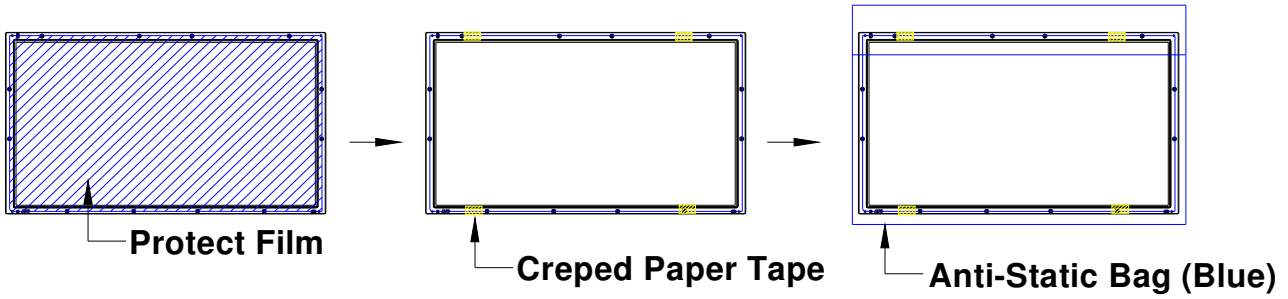

Cushion Set

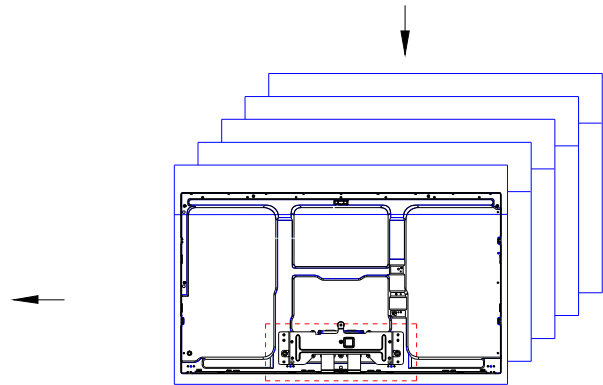

Packing Way : Panel Top Side Down

(5) Pcs Modules

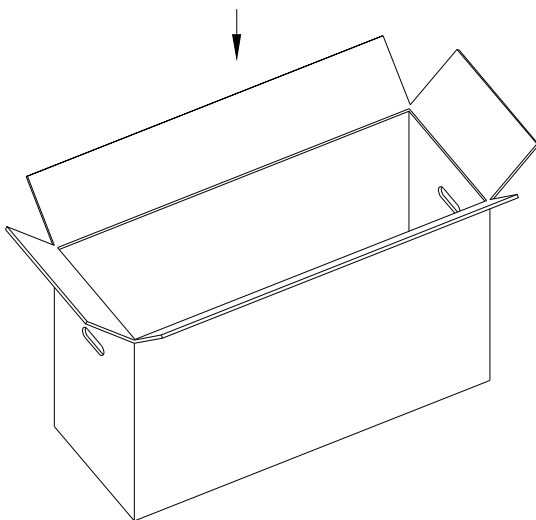

(5) Pcs / 1 Carton

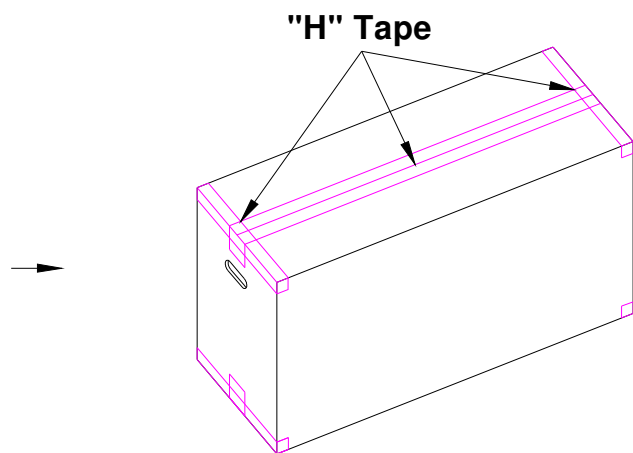

"H" Tape

8-3 Pallet and Shipment Information

	Item	Specification			Packing Remark
		Qty.	Dimension	Weight (kg)	
1	Packing BOX	5 pcs/box	1565(L)*380(W)*978(H)mm	165	
2	Pallet	1	1660(L)*1150(W)*144(H)mm	20	
3	Boxes per Pallet	5 boxes/pallet (by Air); 3 boxes/pallet (by Sea)			
4	Panels per Pallet	25 boxes/pallet (by Air); 15 boxes/pallet (by Sea)			
	Pallet after packing	15	1660(L)*1150(W)*1122(H)mm	465	
	Pallet after packing	30	1660(L)*1150(W)*2244(H)mm	930	

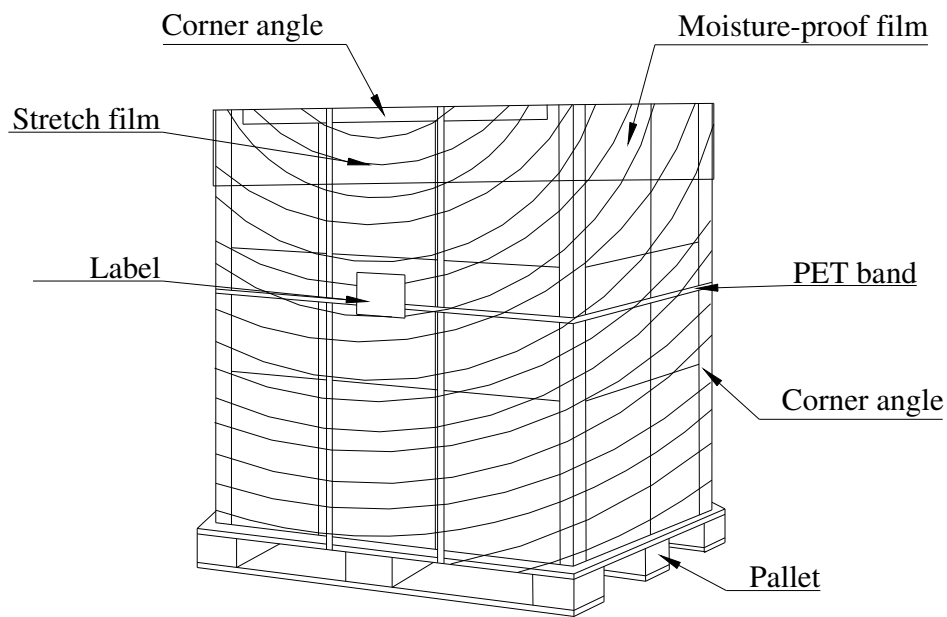

9. PRECAUTIONS

Please pay attention to the followings when you use this TFT LCD module.

9-1 MOUNTING PRECAUTIONS

- (1) You must mount a module using holes arranged in four corners or four sides.
- (2) You should consider the mounting structure so that uneven force (ex. twisted stress) is not applied to module. And the case on which a module is mounted should have sufficient strength so that external force is not transmitted directly to the module.
- (3) Please attach the surface transparent protective plate to the surface in order to protect the polarizer. Transparent protective plate should have sufficient strength in order to resist external force.
- (4) You should adopt radiation structure to satisfy the temperature specification.
- (5) Acetic acid type and chlorine type materials for the cover case are not desirable because the former generates corrosive gas of attacking the polarizer at high temperature and the latter cause circuit broken by electro-chemical reaction.
- (6) Do not touch, push or rub the exposed polarizer with glass, tweezers or anything harder than HB pencil lead. And please do not rub with dust clothes with chemical treatment. Do not touch the surface of polarizer for bare hand or greasy cloth. (Some cosmetics are detrimental to the polarizer.)
- (7) When the surface becomes dusty, please wipe gently with absorbent cotton or other soft materials like chamois soaks with petroleum benzene. Normal-hexane is recommended for cleaning the adhesives used to attach front/ rear polarizer. Do not use acetone, toluene and alcohol because they cause chemical damage to the polarizer.
- (8) Wipe off saliva or water drops as soon as possible. Their long time contact with polarizer causes deformations and color fading.
- (9) Do not open the case because inside circuits do not have sufficient strength.

9-2 OPERATING PRECAUTIONS

- (1) The device listed in the product specification sheets was designed and manufactured for TV application
- (2) The spike noise causes the mis-operation of circuits. It should be lower than following voltage:
 $V = \pm 200\text{mV}$ (Over and under shoot voltage)
- (3) Response time depends on the temperature. (In lower temperature, it becomes longer..)
- (4) Brightness of CCFL depends on the temperature. (In lower temperature, it becomes lower.) And in lower temperature, response time (required time that brightness is stable after turned on) becomes longer.
- (5) Be careful for condensation at sudden temperature change. Condensation makes damage to polarizer or electrical contacted parts. And after fading condensation, smear or spot will occur.
- (6) When fixed patterns are displayed for a long time, remnant image is likely to occur.
- (7) Module has high frequency circuits. Sufficient suppression to the electromagnetic interference shall be done by system manufacturers. Grounding and shielding methods may be important to minimize the interface.

9-3 ELECTROSTATIC DISCHARGE CONTROL

Since a module is composed of electronic circuits, it is not strong to electrostatic discharge. Make certain that treatment persons are connected to ground through wristband etc. And don't touch interface pin directly.

9-4 PRECAUTIONS FOR STRONG LIGHT EXPOSURE

Strong light exposure causes degradation of polarizer and color filter.

9-5 STORAGE

When storing modules as spares for a long time, the following precautions are necessary.

- (1) Store them in a dark place. Do not expose the module to sunlight or fluorescent light. Keep the temperature between 5°C and 35°C at normal humidity.
- (2) The polarizer surface should not come in contact with any other object. It is recommended that they be stored in the container in which they were shipped.

9-6 HANDLING PRECAUTIONS FOR PROTECTION FILM

- (1) The protection film is attached to the bezel with a small masking tape. When the protection film is peeled off, static electricity is generated between the film and polarizer. This should be peeled off slowly and carefully by people who are electrically grounded and with well ion-blown equipment or in such a condition, etc.
- (2) When the module with protection film attached is stored for a long time, sometimes there remains a very small amount of glue still on the bezel after the protection film is peeled off.
- (3) You can remove the glue easily. When the glue remains on the bezel or its vestige is recognized, please wipe them off with absorbent cotton waste or other soft material like chamois soaked with normal-hexane.