

## TOSHIBA CMOS DIGITAL INTEGRATED CIRCUIT SILICON MONOLITHIC

**T6K11****DOT MATRIX LCD DRIVER**

The T6K11 driver is designed for use in small to medium-sized dot matrix LCD panels. This driver can be interfaced to the MPU via a 4 / 8-bit (68 / 80-series) or a serial interface, and is operated asynchronously with the MPU. Since the T6K11 contains an CR circuit clock driver, it can generate the timing signals required for the LCD.

The display data can be stored in the built-in display RAM, whose cells each correspond to each dot on the dot-matrix LCD. The display data written to the RAM corresponds one for one to the LCD drive signals output by the device. Since the T6K11 has 160 outputs for the LCD drive (segment) signals that constitute display data and 65 outputs for the LCD drive (common) signals that constitute scanning signals, this single device allows you to drive an LCD panel comprised of up to 160 × 65 dots with a minimum of power requirement.

To minimize its power consumption, the T6K11 has a display change mode (power save mode) in which only a 160 × 1-dot icon can be displayed. What's more, it has various built-in analog circuits such as a D / A converter for the LCD drive power supply, a step-up circuit (×2 to ×5), and a contrast control (electronic VR) circuit. All these circuits enable the LCD panel to be driven with a single power supply.

This product is under development; hence, specifications may change without notice. When you use this product, please refer to the latest technical datasheet.

Unit : mm

T6K11	USER AREA PITCH	
	IN	OUT
(UBW, 5NS)	0.6	0.23

Please contact Toshiba or an authorized Toshiba dealer for the latest TCP specification and product lineup.

TCP (Tape Carrier Package)

000707EBE1

- TOSHIBA is continually working to improve the quality and reliability of its products. Nevertheless, semiconductor devices in general can malfunction or fail due to their inherent electrical sensitivity and vulnerability to physical stress. It is the responsibility of the buyer, when utilizing TOSHIBA products, to comply with the standards of safety in making a safe design for the entire system, and to avoid situations in which a malfunction or failure of such TOSHIBA products could cause loss of human life, bodily injury or damage to property.  
In developing your designs, please ensure that TOSHIBA products are used within specified operating ranges as set forth in the most recent TOSHIBA products specifications. Also, please keep in mind the precautions and conditions set forth in the "Handling Guide for Semiconductor Devices," or "TOSHIBA Semiconductor Reliability Handbook" etc..
- The TOSHIBA products listed in this document are intended for usage in general electronics applications (computer, personal equipment, office equipment, measuring equipment, industrial robotics, domestic appliances, etc.). These TOSHIBA products are neither intended nor warranted for usage in equipment that requires extraordinarily high quality and/or reliability or a malfunction or failure of which may cause loss of human life or bodily injury ("Unintended Usage"). Unintended Usage include atomic energy control instruments, airplane or spaceship instruments, transportation instruments, traffic signal instruments, combustion control instruments, medical instruments, all types of safety devices, etc.. Unintended Usage of TOSHIBA products listed in this document shall be made at the customer's own risk.
- Polyimide base film is hard and thin. Be careful not to injure yourself on the film or to scratch any other parts with the film. Try to design and manufacture products so that there is no chance of users touching the film after assembly, or if they do, that there is no chance of them injuring themselves. When cutting out the film, try to ensure that the film shavings do not cause accidents. After use, treat the leftover film and reel spacers as industrial waste.
- Light striking a semiconductor device generates electromotive force due to photoelectric effects. In some cases this can cause the device to malfunction.  
This is especially true for devices in which the surface (back), or side of the chip is exposed. When designing circuits, make sure that devices are protected against incident light from external sources. Exposure to light both during regular operation and during inspection must be taken into account.
- The products described in this document are subject to the foreign exchange and foreign trade laws.
- The information contained herein is presented only as a guide for the applications of our products. No responsibility is assumed by TOSHIBA CORPORATION for any infringements of intellectual property or other rights of the third parties which may result from its use. No license is granted by implication or otherwise under any intellectual property or other rights of TOSHIBA CORPORATION or others.
- The information contained herein is subject to change without notice.

## Features

- Display RAM : 160 (64 + 1) = 10,400 bits
- LCD drive outputs : 160 segment outputs  
65 common outputs (including one common output for icon)
- RAM data direct display : Turned on when bit data in RAM = 1  
Turned off when bit data in RAM = 0
- Display duty cycle : 1/2 duty during power save mode  
1/35, 1/49, 1/57, or 1/65 duty during normal mode  
(Duty cycles in normal mode are set in software by the MPU.)
- Display modes : Normal mode ..... Full display  
Power save mode ..... Icon display  
Standby mode ..... Clock stop (all internal circuits turned off)
- MPU : 8-bit (68 / 80 series) parallel or serial interface
- Oscillator : Built-in CR oscillator (resistor and capacitor completely built-in), external clock input acceptable
- Power supply circuits : D/A converter for LCD drive power supply (temperature derating = 0.20% / °C), step-up circuit (×2 to ×5), contrast control circuit
- Operating voltages : AVDD (used for analog) = DVDD to 5.5 V  
DVDD (used for digital) = 1.8 to 3.3 V
- LCD drive voltage : VCC = 16.5 V (max)
- CMOS process
- Low power consumption : ISS = 103 μA (typ.)  
Conditions: AVDD = DVDD = 3.0 V, step-up circuit used (×4 mode), LCD nonloaded, Ta = 25°C, display data = all “checker pattern,” no data access from MPU
- Package :

Product	Package
T6K11(XXX, XXX)	TCP (Tape carrier package)
JBT6K11-AS	Gold Bump Chip



## Pin Assignment

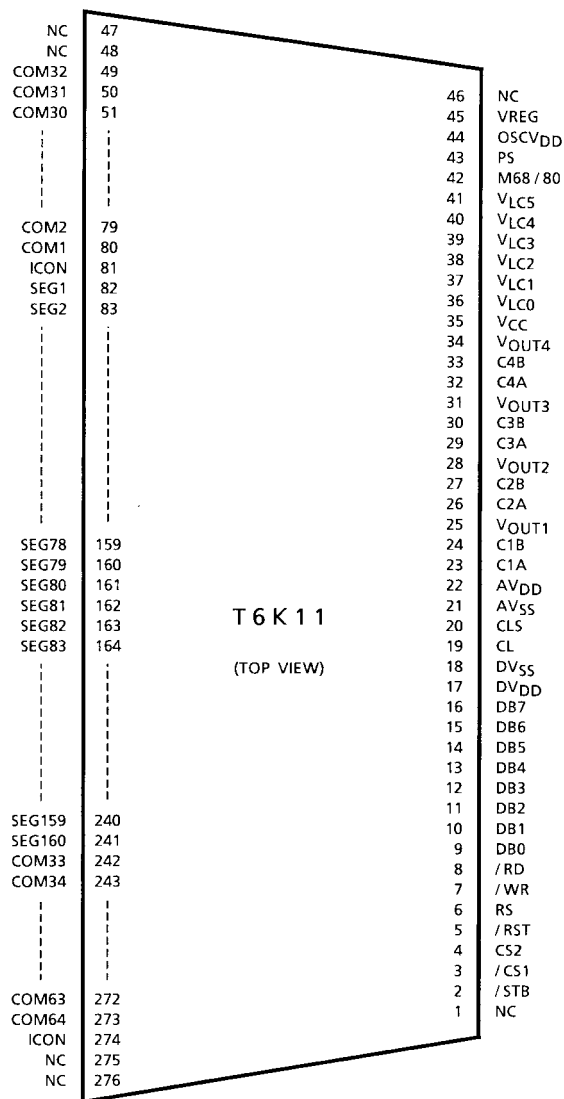

Note: The above TCP pin assignment is shown for reference purposes only.

## Pad Specification

Item	Size	Unit
Chip size	10360 × 2550	μm
Chip tip coordinates	(1) -5180 , -1275	μm
	(2) -5180 , 1275	
	(3) 5180 , 1275	
	(4) 5180 , -1275	
Bump pitch	60	μm
Bump height	14 ± 4	μm

Item	Number of pins
Input pin	116 pin (including dummy pins)
Output pin	226 pin (including dummy pins)
Fuse pin	33 pin (including dummy pins) (Note 1)
Test pin	19 pin (Note 1)

(Note 1): Fuse (No.117 to 149) and Test (No.376 to 394) are LSI test pins, leave these pins open.

Pad Layout

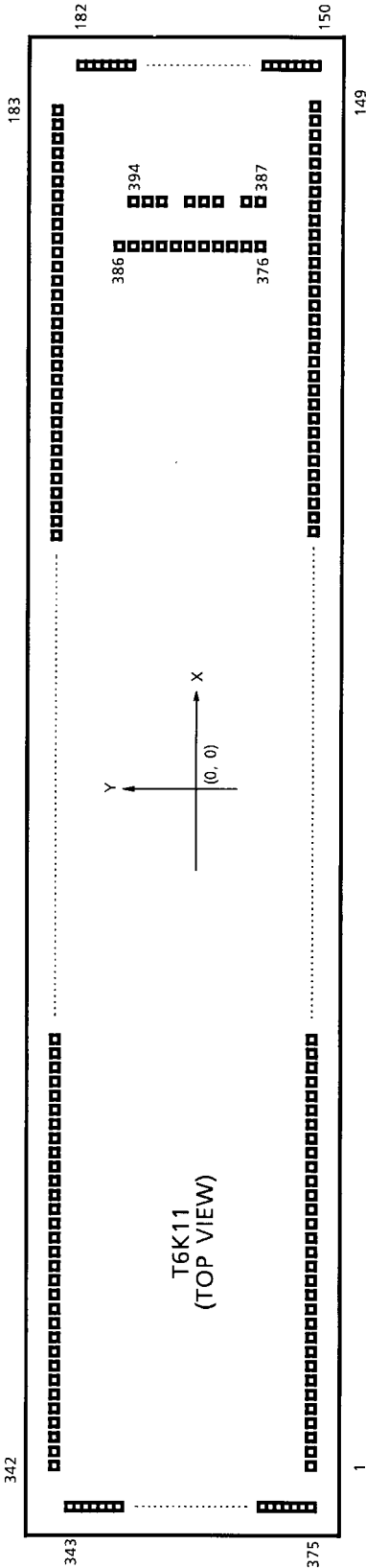

## Pad Coordinates

(Unit:  $\mu\text{m}$ )

No.	Name	X	Y	No.	Name	X	Y	No.	Name	X	Y
1	DV <sub>DD</sub>	-4753	-1090	41	AV <sub>SS</sub>	-2176	-1090	81	V <sub>LC0</sub>	384	-1090
2	/STB	-4672	-1090	42	AV <sub>SS</sub>	-2112	-1090	82	V <sub>LC0</sub>	448	-1090
3	DV <sub>SS</sub>	-4608	-1090	43	DUMMY5	-2048	-1090	83	V <sub>LC1</sub>	512	-1090
4	/CS1	-4544	-1090	44	AV <sub>DD</sub>	-1984	-1090	84	V <sub>LC1</sub>	576	-1090
5	CS2	-4480	-1090	45	AV <sub>DD</sub>	-1920	-1090	85	V <sub>LC2</sub>	640	-1090
6	DV <sub>DD</sub>	-4416	-1090	46	AV <sub>DD</sub>	-1856	-1090	86	V <sub>LC2</sub>	704	-1090
7	/RST	-4352	-1090	47	AV <sub>DD</sub>	-1792	-1090	87	DUMMY9	768	-1090
8	DUMMY1	-4288	-1090	48	DUMMY6	-1728	-1090	88	V <sub>LC3</sub>	832	-1090
9	RS	-4224	-1090	49	C1A	-1664	-1090	89	V <sub>LC3</sub>	896	-1090
10	DV <sub>SS</sub>	-4160	-1090	50	C1A	-1600	-1090	90	V <sub>LC4</sub>	960	-1090
11	/WR	-4096	-1090	51	C1B	-1536	-1090	91	V <sub>LC4</sub>	1024	-1090
12	/RD	-4032	-1090	52	C1B	-1472	-1090	92	V <sub>LC5</sub>	1088	-1090
13	DV <sub>DD</sub>	-3968	-1090	53	V <sub>OUT1</sub>	-1408	-1090	93	V <sub>LC5</sub>	1152	-1090
14	DB0	-3904	-1090	54	V <sub>OUT1</sub>	-1344	-1090	94	DUMMY10	1216	-1090
15	DB1	-3840	-1090	55	C2A	-1280	-1090	95	AV <sub>SS</sub>	1280	-1090
16	DB2	-3776	-1090	56	C2A	-1216	-1090	96	DUMMY11	1344	-1090
17	DB3	-3712	-1090	57	C2B	-1152	-1090	97	DV <sub>SS</sub>	1408	-1090
18	DB4	-3648	-1090	58	C2B	-1088	-1090	98	68/80	1472	-1090
19	DB5	-3584	-1090	59	V <sub>OUT2</sub>	-1024	-1090	99	DV <sub>DD</sub>	1536	-1090
20	DB6	-3520	-1090	60	V <sub>OUT2</sub>	-960	-1090	100	P/S	1600	-1090
21	DB7	-3456	-1090	61	C3A	-896	-1090	101	DV <sub>SS</sub>	1664	-1090
22	DUMMY2	-3392	-1090	62	C3A	-832	-1090	102	DUMMY12	1728	-1090
23	DV <sub>DD</sub>	-3328	-1090	63	C3B	-768	-1090	103	DUMMY13	1792	-1090
24	DV <sub>DD</sub>	-3264	-1090	64	C3B	-704	-1090	104	DUMMY14	1856	-1090
25	DV <sub>DD</sub>	-3200	-1090	65	V <sub>OUT3</sub>	-640	-1090	105	DUMMY15	1920	-1090
26	DV <sub>DD</sub>	-3136	-1090	66	V <sub>OUT3</sub>	-576	-1090	106	DUMMY16	1984	-1090
27	DV <sub>DD</sub>	-3072	-1090	67	C4A	-512	-1090	107	DUMMY17	2048	-1090
28	DUMMY3	-3008	-1090	68	C4A	-448	-1090	108	DUMMY18	2112	-1090
29	DV <sub>SS</sub>	-2944	-1090	69	C4B	-384	-1090	109	DUMMY19	2176	-1090
30	DV <sub>SS</sub>	-2880	-1090	70	C4B	-320	-1090	110	DUMMY20	2240	-1090
31	DV <sub>SS</sub>	-2816	-1090	71	V <sub>OUT4</sub>	-256	-1090	111	DUMMY21	2304	-1090
32	DV <sub>SS</sub>	-2752	-1090	72	V <sub>OUT4</sub>	-192	-1090	112	DUMMY22	2368	-1090
33	DV <sub>SS</sub>	-2688	-1090	73	V <sub>CC</sub>	-128	-1090	113	DUMMY23	2432	-1090
34	CL	-2624	-1090	74	V <sub>CC</sub>	-64	-1090	114	DUMMY24	2496	-1090
35	DV <sub>DD</sub>	-2560	-1090	75	V <sub>CC</sub>	0	-1090	115	OSCV <sub>DD</sub>	2560	-1090
36	CLS	-2496	-1090	76	V <sub>CC</sub>	64	-1090	116	VREG	2624	-1090
37	DV <sub>SS</sub>	-2432	-1090	77	DUMMY7	128	-1090	117	DUMMY25	2688	-1090
38	DUMMY4	-2368	-1090	78	AV <sub>SS</sub>	192	-1090	118	FUSE1	2752	-1090
39	AV <sub>SS</sub>	-2304	-1090	79	AV <sub>SS</sub>	256	-1090	119	DUMMY26	2816	-1090
40	AV <sub>SS</sub>	-2240	-1090	80	DUMMY8	320	-1090	120	FUSE2	2880	-1090

(Unit:  $\mu\text{m}$ )

No.	Name	X	Y	No.	Name	X	Y	No.	Name	X	Y
121	DUMMY27	2944	-1090	161	COM21	4988	-410	201	SEG19	3690	1083
122	FUSE3	3008	-1090	162	COM20	4988	-350	202	SEG20	3630	1083
123	DUMMY28	3072	-1090	163	COM19	4988	-290	203	SEG21	3570	1083
124	FUSE4	3136	-1090	164	COM18	4988	-230	204	SEG22	3510	1083
125	DUMMY29	3200	-1090	165	COM17	4988	-170	205	SEG23	3450	1083
126	FUSE5	3264	-1090	166	COM16	4988	-110	206	SEG24	3390	1083
127	DUMMY30	3328	-1090	167	COM15	4988	-50	207	SEG25	3330	1083
128	FUSE6	3392	-1090	168	COM14	4988	10	208	SEG26	3270	1083
129	DUMMY31	3456	-1090	169	COM13	4988	70	209	SEG27	3210	1083
130	FUSE7	3520	-1090	170	COM12	4988	130	210	SEG28	3150	1083
131	DUMMY32	3584	-1090	171	COM11	4988	190	211	SEG29	3090	1083
132	FUSE8	3648	-1090	172	COM10	4988	250	212	SEG30	3030	1083
133	DUMMY33	3712	-1090	173	COM9	4988	310	213	SEG31	2970	1083
134	FUSE9	3776	-1090	174	COM8	4988	370	214	SEG32	2910	1083
135	DUMMY34	3840	-1090	175	COM7	4988	430	215	SEG33	2850	1083
136	FUSE10	3904	-1090	176	COM6	4988	490	216	SEG34	2790	1083
137	DUMMY35	3968	-1090	177	COM5	4988	550	217	SEG35	2730	1083
138	FUSE11	4032	-1090	178	COM4	4988	610	218	SEG36	2670	1083
139	DUMMY36	4096	-1090	179	COM3	4988	670	219	SEG37	2610	1083
140	FUSE12	4160	-1090	180	COM2	4988	730	220	SEG38	2550	1083
141	DUMMY37	4224	-1090	181	COM1	4988	790	221	SEG39	2490	1083
142	FUSE13	4288	-1090	182	ICONA	4988	870	222	SEG40	2430	1083
143	DUMMY38	4352	-1090	183	SEG1	4790	1083	223	SEG41	2370	1083
144	FUSE14	4416	-1090	184	SEG2	4710	1083	224	SEG42	2310	1083
145	DUMMY39	4480	-1090	185	SEG3	4650	1083	225	SEG43	2250	1083
146	FUSE15	4544	-1090	186	SEG4	4590	1083	226	SEG44	2190	1083
147	FUSE16	4608	-1090	187	SEG5	4530	1083	227	SEG45	2130	1083
148	DUMMY40	4672	-1090	188	SEG6	4470	1083	228	SEG46	2070	1083
149	FUSE17	4753	-1090	189	SEG7	4410	1083	229	SEG47	2010	1083
150	COM32	4988	-1090	190	SEG8	4350	1083	230	SEG48	1950	1083
151	COM31	4988	-1010	191	SEG9	4290	1083	231	SEG49	1890	1083
152	COM30	4988	-950	192	SEG10	4230	1083	232	SEG50	1830	1083
153	COM29	4988	-890	193	SEG11	4170	1083	233	SEG51	1770	1083
154	COM28	4988	-830	194	SEG12	4110	1083	234	SEG52	1710	1083
155	COM27	4988	-770	195	SEG13	4050	1083	235	SEG53	1650	1083
156	COM26	4988	-710	196	SEG14	3990	1083	236	SEG54	1590	1083
157	COM25	4988	-650	197	SEG15	3930	1083	237	SEG55	1530	1083
158	COM24	4988	-590	198	SEG16	3870	1083	238	SEG56	1470	1083
159	COM23	4988	-530	199	SEG17	3810	1083	239	SEG57	1410	1083
160	COM22	4988	-470	200	SEG18	3750	1083	240	SEG58	1350	1083



(Unit:  $\mu\text{m}$ )

No.	Name	X	Y	No.	Name	X	Y	No.	Name	X	Y
241	SEG59	1290	1083	281	SEG99	-1110	1083	321	SEG139	-3510	1083
242	SEG60	1230	1083	282	SEG100	-1170	1083	322	SEG140	-3570	1083
243	SEG61	1170	1083	283	SEG101	-1230	1083	323	SEG141	-3630	1083
244	SEG62	1110	1083	284	SEG102	-1290	1083	324	SEG142	-3690	1083
245	SEG63	1050	1083	285	SEG103	-1350	1083	325	SEG143	-3750	1083
246	SEG64	990	1083	286	SEG104	-1410	1083	326	SEG144	-3810	1083
247	SEG65	930	1083	287	SEG105	-1470	1083	327	SEG145	-3870	1083
248	SEG66	870	1083	288	SEG106	-1530	1083	328	SEG146	-3930	1083
249	SEG67	810	1083	289	SEG107	-1590	1083	329	SEG147	-3990	1083
250	SEG68	750	1083	290	SEG108	-1650	1083	330	SEG148	-4050	1083
251	SEG69	690	1083	291	SEG109	-1710	1083	331	SEG149	-4110	1083
252	SEG70	630	1083	292	SEG110	-1770	1083	332	SEG150	-4170	1083
253	SEG71	570	1083	293	SEG111	-1830	1083	333	SEG151	-4230	1083
254	SEG72	510	1083	294	SEG112	-1890	1083	334	SEG152	-4290	1083
255	SEG73	450	1083	295	SEG113	-1950	1083	335	SEG153	-4350	1083
256	SEG74	390	1083	296	SEG114	-2010	1083	336	SEG154	-4410	1083
257	SEG75	330	1083	297	SEG115	-2070	1083	337	SEG155	-4470	1083
258	SEG76	270	1083	298	SEG116	-2130	1083	338	SEG156	-4530	1083
259	SEG77	210	1083	299	SEG117	-2190	1083	339	SEG157	-4590	1083
260	SEG78	150	1083	300	SEG118	-2250	1083	340	SEG158	-4650	1083
261	SEG79	90	1083	301	SEG119	-2310	1083	341	SEG159	-4710	1083
262	SEG80	30	1083	302	SEG120	-2370	1083	342	SEG160	-4790	1083
263	SEG81	-30	1083	303	SEG121	-2430	1083	343	COM33	-4988	870
264	SEG82	-90	1083	304	SEG122	-2490	1083	344	COM34	-4988	790
265	SEG83	-150	1083	305	SEG123	-2550	1083	345	COM35	-4988	730
266	SEG84	-210	1083	306	SEG124	-2610	1083	346	COM36	-4988	670
267	SEG85	-270	1083	307	SEG125	-2670	1083	347	COM37	-4988	610
268	SEG86	-330	1083	308	SEG126	-2730	1083	348	COM38	-4988	550
269	SEG87	-390	1083	309	SEG127	-2790	1083	349	COM39	-4988	490
270	SEG88	-450	1083	310	SEG128	-2850	1083	350	COM40	-4988	430
271	SEG89	-510	1083	311	SEG129	-2910	1083	351	COM41	-4988	370
272	SEG90	-570	1083	312	SEG130	-2970	1083	352	COM42	-4988	310
273	SEG91	-630	1083	313	SEG131	-3030	1083	353	COM43	-4988	250
274	SEG92	-690	1083	314	SEG132	-3090	1083	354	COM44	-4988	190
275	SEG93	-750	1083	315	SEG133	-3150	1083	355	COM45	-4988	130
276	SEG94	-810	1083	316	SEG134	-3210	1083	356	COM46	-4988	70
277	SEG95	-870	1083	317	SEG135	-3270	1083	357	COM47	-4988	10
278	SEG96	-930	1083	318	SEG136	-3330	1083	358	COM48	-4988	-50
279	SEG97	-990	1083	319	SEG137	-3390	1083	359	COM49	-4988	-110
280	SEG98	-1050	1083	320	SEG138	-3450	1083	360	COM50	-4988	-170

(Unit:  $\mu\text{m}$ )

No.	Name	X	Y	No.	Name	X	Y	No.	Name	X	Y
361	COM51	-4988	-230	373	COM63	-4988	-950	385	TEST10	3575	339
362	COM52	-4988	-290	374	COM64	-4988	-1010	386	TEST11	3575	439
363	COM53	-4988	-350	375	ICONB	-4988	-1090	387	TEST12	3795	-573
364	COM54	-4988	-410	376	TEST1	3575	-573	388	TEST13	3795	-473
365	COM55	-4988	-470	377	TEST2	3575	-473	389	TEST14	3795	-261
366	COM56	-4988	-530	378	TEST3	3575	-373	390	TEST15	3795	-161
367	COM57	-4988	-590	379	TEST4	3575	-261	391	TEST16	3795	-61
368	COM58	-4988	-650	380	TEST5	3575	-161	392	TEST17	3795	139
369	COM59	-4988	-710	381	TEST6	3575	-61	393	TEST18	3795	239
370	COM60	-4988	-770	382	TEST7	3575	39	394	TEST19	3795	339
371	COM61	-4988	-830	383	TEST8	3575	139				
372	COM62	-4988	-890	384	TEST9	3575	239				

## Pin Function

Pin Name	Pin No.	I/O	Function
SEG1~160		Output	LCD drive segment signals
COM1~64		Output	LCD drive common signals
ICON		Output	LCD drive common signal (used for icon)
DB0~DB5		I / O	Data bus When P/S = low, DB0 to DB5 are placed in the high-impedance state.
DB6 (SCK)		I / O	Data bus When P/S = low, this bus functions as the serial interface's data synchronizing clock (SCK).
DB7 (SI)		I / O	Data bus When P/S = low, this bus functions as the serial interface's data input pin (SI).
RS		Input	Register mode select signal <ul style="list-style-type: none"> <li>When RS = low, this input is recognized as a register number.</li> <li>When RS = high, this input is recognized as the data to be written to the register.</li> </ul>
/RD (E)		Input	Read select signal <ul style="list-style-type: none"> <li>When 68/80 = low (80-series MPU selected), data is output while this pin is held low. Data is latched in at the active edge.</li> <li>When 68/80 = high (68-series MPU selected), this pin is used as an enable signal input pin (E).</li> </ul>
/WR (R/W)		Input	Write select signal <ul style="list-style-type: none"> <li>When 68/80 = low (80-series MPU selected), data is latched at the rising edge of /WR.</li> <li>When 68/80 = high (68-series MPU selected), data read is selected if R/W = high or data write is selected if R/W = low.</li> </ul>
/CS1		Input	Chip select signal (1) Data/commands can be input or output while this signal is held low.
CS2		Input	Chip select signal (2) Data/commands can be input or output while this signal is held high.
/RST		Input	Reset signal The device is reset when this signal is pulled low.
P/S		Input	Parallel/serial interface select signal <ul style="list-style-type: none"> <li>The parallel interface is selected when this signal is high.</li> <li>The serial interface is selected when this signal is low.</li> </ul>
68/80		Input	68/80-series parallel MPU select signal <ul style="list-style-type: none"> <li>The 68-series parallel MPU is selected when this signal is high.</li> <li>The 80-series parallel MPU is selected when this signal is low.</li> </ul>
CLS		Input	CR oscillator circuit ON/OFF select signal <ul style="list-style-type: none"> <li>The internal CR oscillator is turned on when CLS is high.</li> <li>The internal CR oscillator is turned off when CLS is low, allowing for an external clock input to be used. In this case, use the CL pin to supply the external clock.</li> </ul>
CL		I / O	Display clock input pin <ul style="list-style-type: none"> <li>When CLS = high, this pin functions as the internal CR circuit's clock monitor pin.</li> <li>When CLS = low, this pin is used to input an external clock to the device.</li> </ul>
/STB		Input	Standby signal The device is placed in standby state when / STB is low.
C1A, C1B		—	External capacitor connecting pin for ×2 step-up
VOUT1		—	×2 step-up voltage output pin
C2A, C2B		—	External capacitor connecting pin for ×3 step-up
VOUT2		—	×3 step-up voltage output pin
C3A, C3B		—	External capacitor connecting pin for ×4 step-up
VOUT3		—	×4 step-up voltage output pin
C4A, C4B		—	External capacitor connecting pin for ×5 step-up
VOUT4		—	×5 step-up voltage output pin
VREG		—	LV regulator output pin (Note 1)
V <sub>CC</sub>		—	LCD drive power supply pin (Note 1)

Pin Name	Pin No.	I/O	Function
VLC0 to VLC4		—	LCD drive power supply pin (Note 1)
VLC5		—	LCD drive power supply pin: Connect to V <sub>SS</sub>
OSCV <sub>DD</sub>		—	CR oscillator circuit regulator output pin: Leave this pin open.
AV <sub>DD</sub> , AV <sub>SS</sub>		—	Analog circuit power supply pin
DV <sub>DD</sub> , DV <sub>SS</sub>		—	Digital circuit power supply pin
FUSE1 to 17		—	LSI Test pins: Leave these pins open.
TEST1 to 19		—	LSI Test pins: Leave these pins open.

(Note 1): Connect the capacitor between this pin and V<sub>SS</sub>.

## Function Each Block

- MPU interface unit

Depending on whether the 68/80 input and P/S input pins are high or low, the T6K11 selects an 8-bit parallel or a serial interface, allowing for data to be transferred from the MPU.

P/S	68/80	Interface Type	/CS1	CS2	RS	/WR	/RD	DB7	DB6	DB5 to 0
H	L	80-series MPU (/CS1)	/CS1	H	RS	/WR	/RD	DB7	DB6	DB5 to 0
		80-series MPU (CS2)	L	CS2	RS	/WR	/RD	DB7	DB6	DB5 to 0
	H	68-series MPU	L	H	RS	R/W	E	DB7	DB6	DB5 to 0
L	—	Serial	L	H	RS	H/L	H/L	SI	SCK	Hi-Z

Note: "H" denotes the DV<sub>DD</sub> level; "L" denotes the DV<sub>SS</sub> level.

**(a) For the 80-series MPU**

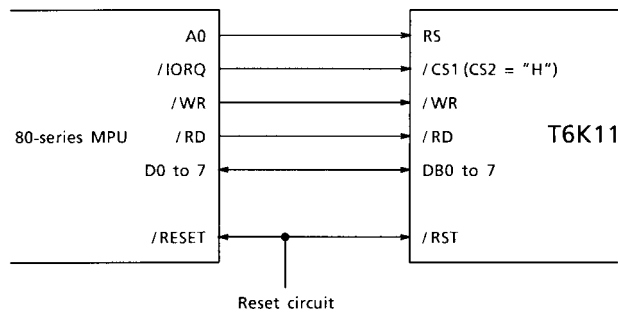

**(b) For the 68-series MPU**

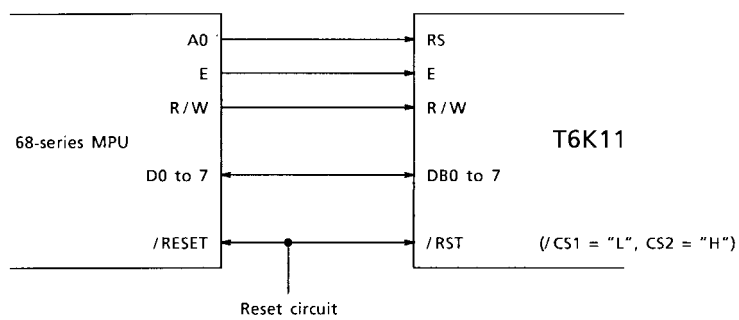

**(c) For serial interface**

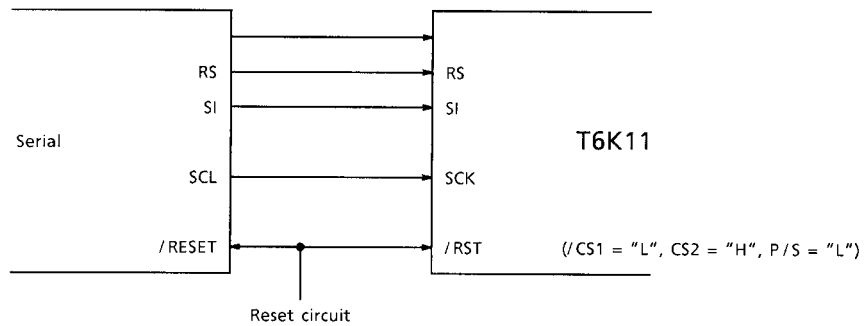

**Fig. 1**

When the serial interface is selected ( $P/S = \text{low}$ ), data and serial clock from the MPU are accepted providing that  $/CS1 = \text{low}$  and  $CS2 = \text{high}$ . The serial data input to the device is taken in from SI in order of DB7, DB6, ...DB0 at each rising edge of SCK, and are converted into parallel data at the 8th rising edge of SCK. Recognition of the received data depends on the RS pin status at the 8th rising edge of SCK. If  $RS = \text{low}$ , the data is recognized as a register number set; if  $RS = \text{high}$ , the data is recognized as write data. A serial interface timing chart is shown in Fig. 2.

Note that when using the serial interface, the device can only write data to its internal logic and registers, and cannot read data and status.

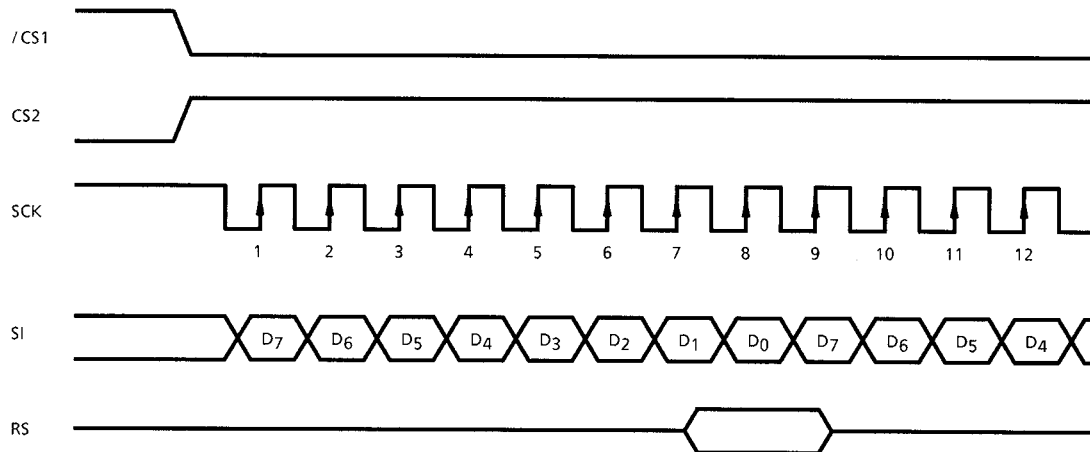

Fig. 2

- **Input / output buffer**

This buffer is used to transfer data between the T6K11 and the MPU. For a parallel interface, this buffer is used as an 8-bit data bus; for a serial interface, it is used to receive serial data and serial clock, with the serial data converted into parallel data before being taken into the internal circuit.

- **Input register**

This register holds the data from the MPU. The data held in this register is recognized as a register number or write data depending on whether RS is high or low.

- **Output register**

This register holds 8-bit data when transferring display RAM data or status information to the MPU.

- **X-address counter**

This counter is a 64-Up / Down counter used to hold the row address of the display RAM. When this counter is selected by a command, it is automatically incremented or decremented each time data is read or written to the display RAM.

- **Y-address counter**

This counter is a 20-Up / Down counter used to hold the column address of the display RAM. When this counter is selected by a command, it is automatically increased or decreased each time data is read or written to the display RAM.

- **Z counter**

This counter is a 64-Up counter used to supply the display data stored in the display RAM to the LCD drive circuit. The data held in the Z-address register is loaded into this counter as Z-address. Therefore, if this counter is set to 20, for example, it counts up from 20 to 21, 22, ...62, 63, (icon) and from 0 to 1, 2, ...18, 19, 20. The start line on the LCD screen is line 20 of the display RAM. Note, however, that the icon line (64) cannot be made the start line of the Z-address.

- **X / Y counter up / down register**

This register holds the data that selects the up-count or down-count mode for the X and Y counters.

- **X / Y counter select register**

This register holds the data that selects the X or Y counter to be used.

- **Display ON / OFF register**

This 1-bit register holds the data that determines whether the display be turned on or off. When turned OFF, outputs from the display RAM are reset. When turned ON, the display data corresponding to those in the display RAM are output to the LCD. Since the data in the display RAM does not affect display ON/OFF command control, the display RAM is not cleared anyway.

- **Z-address register**

This 6-bit register holds the data that determines the display start line. By setting Z-address in this register successively, it is possible to scroll the display up or down.

- **Oscillator**

The clocking source can be switched between the built-in CR oscillator or an external clock depending on the CLS pin status as shown in Fig. 3. When CLS = high, the CR oscillator is enabled, supplying display clock to the internal logic. When CLS = low, the CL pin is switched for input, accepting an external clock.

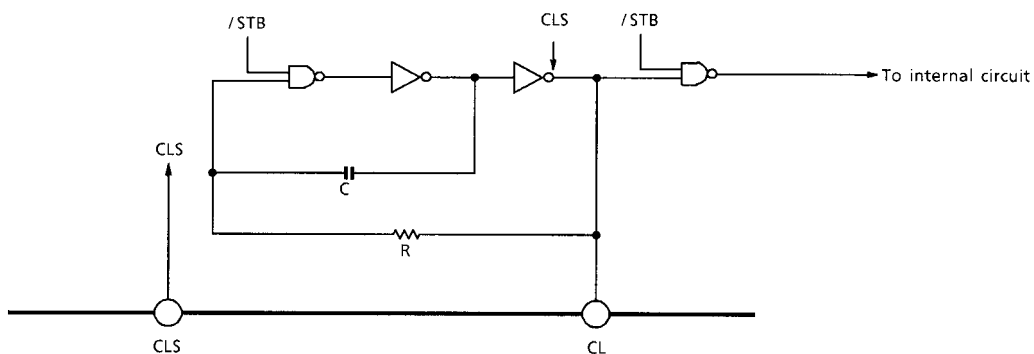

Fig. 3



- **Timing signal generation circuit**

This circuit generates the timing signals and operation clock required for display by dividing the clock frequency derived from the CR circuit or an external source.

- **Shift registers**

The T6K11 contains a 64-bit shift register necessary to shift the turn-on data required for the LCD drive common signals and a 1-bit shift register used for the icon.

- **Duty cycle control register**

This register holds the data that sets one of the four duty cycles that can be used.

- **Contrast control register**

This register holds 4-stage VLC0 control data and 64-stage contrast control data.

- **Step-up circuit ON / OFF register**

This register holds the data that determines whether the step-up circuit be turned on or off.

- **D / A converter ON / OFF register**

This register holds the data that determines whether the D/A converter be turned on or off.

- **Bias control register**

This register holds the data that sets one of the four bias values that can be used.

- **Latch circuit**

This circuit latches display data from the RAM.

- **LCD drive circuit (segment)**

The segment driver circuit consists of 160 drivers.

Each driver outputs one of the four LCD drive voltage levels depending on a combination of the display data from the latch circuit and the M signal (used for FR) as shown in Fig. 4.

The segment driver circuit is shown below.

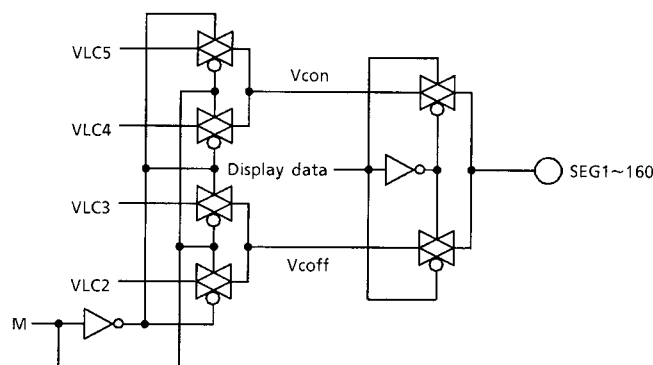
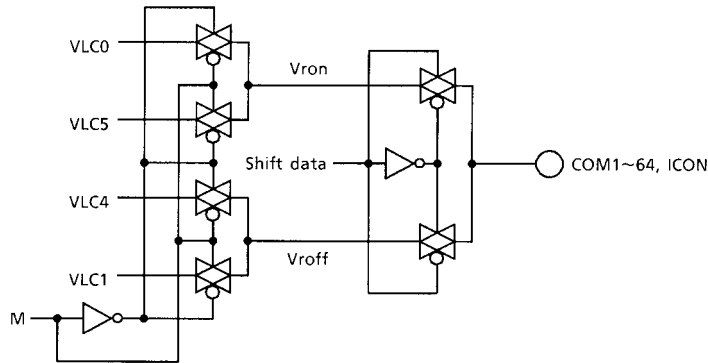

**Fig. 4**

• **LCD drive circuit (common)**

The common driver circuit consists of 65 drivers. Each driver outputs one of the four LCD drive voltage levels depending on a combination of the data from the shift register and the M signal (used for FR) as shown in Fig. 5.

The common driver circuit is shown below.



**Fig. 5**

• **Step-up circuit**

The T6K11 contains a  $\times 2/3/4/5$  step-up circuit. When /RST = low or /STB = low, VOUT = 0 V (VSS level). Normally, capacitors of more or less 2.2  $\mu\text{F}$  are used for the step-up capacitor and step-up level retaining capacitor. Since the step-up circuit power supply AVDD pin normally allows voltages to be input that are higher than possible for the digital-block power supply DVDD pin, this circuit can generate the necessary LCD drive voltage. However, because the rated LCD drive voltage is 16.5 V (max), care must be taken for the voltage condition (AVDD voltage) used in step-up circuit and the number of boost steps to ensure that the boosted voltage (the voltage output from VOUT) will not exceed the rated voltage of 16.5 V.

Note 1: Relationship of power supply voltages  
 ..... 5.5 V  $\geq$  AVDD  $\geq$  DVDD  $\geq$  2.4 V

Note 2: Relationship between step-up output voltage and LCD drive voltage  
 ..... 16.5 V  $\geq$  AVDD  $\times$  n ('n' denotes the number of boost steps.)

Example): When using a  $\times 5$  step-up circuit

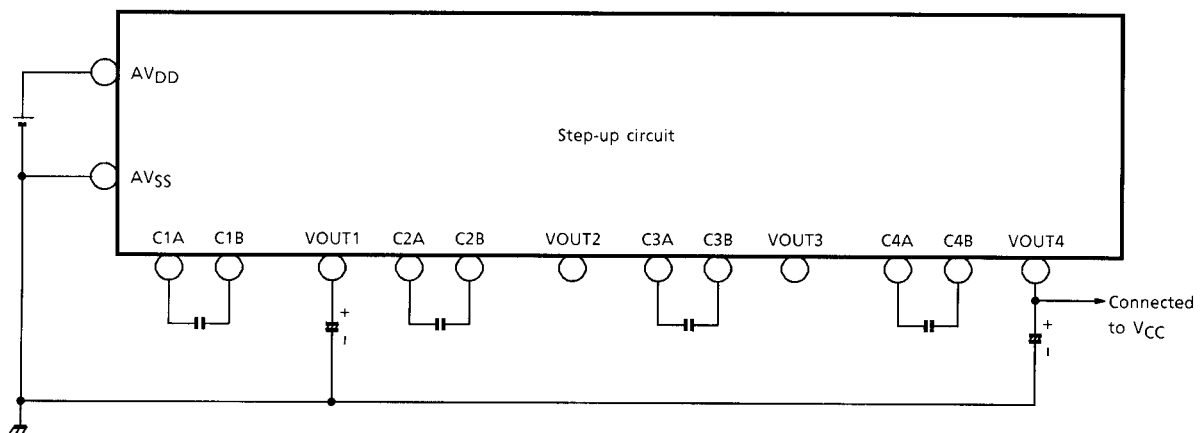

**Fig. 6**

**Recommended Pin Processing When using a Step-up Circuit**

Conditions	C1A, C1B	VOUT1	C2A, C2B	VOUT2	C3A, C3B	VOUT3	C4A, C4B	VOUT4
When using ×2 step-up circuit	Available	Available	Open	Open	Open	Open	Open	Open
When using ×3 step-up circuit	Available	Available	Available	Available	Open	Open	Open	Open
When using ×4 step-up circuit	Available	Available	Available	Open	Available	Available	Open	Open
When using ×5 step-up circuit	Available	Available	Available	Open	Available	Open	Available	Available

Note: "Available" means that a capacitor is connected to the pin.

● **Contrast control, bias control, and D / A converter**

The T6K11 contains a power supply generating circuit for LCD drive which is comprised of the D / A converter. The contrast (electronic VR) and bias required for each type of LCD panel are controlled by this circuit. Refer to Fig. 7 for a block diagram of this power supply circuit.

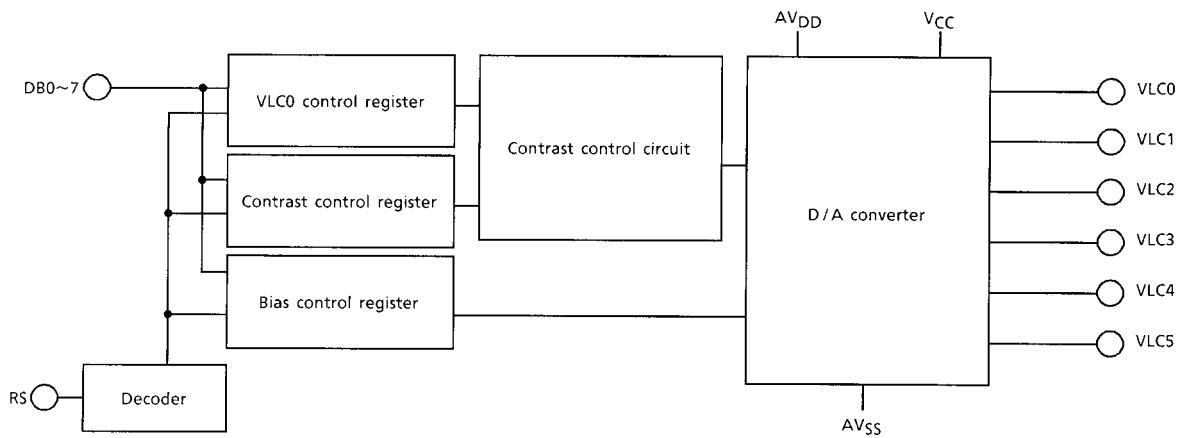
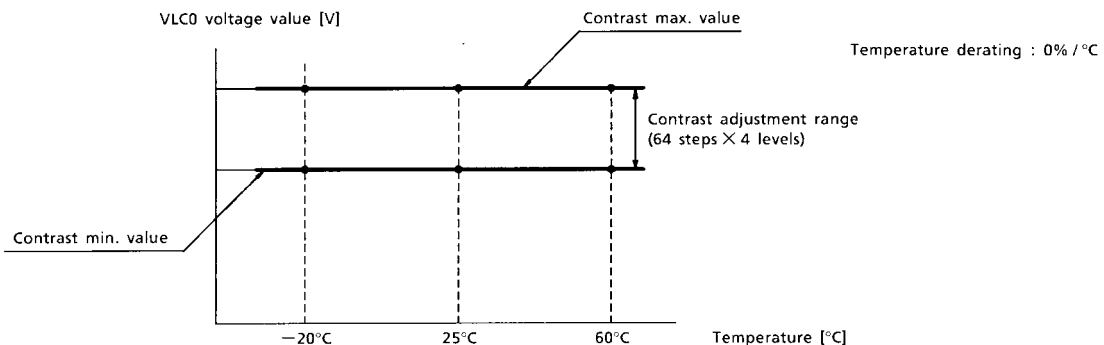

**Fig. 7**

**Resistor Ratios for Adjusting LCD Drive Voltage (VLC0)**

VLC0 Control		VLC0 Voltage Typ. Value (Max Contrast)	Number of Contrast Steps	VCC Input Voltage Min Value	Remark
DB7	DB6				
1	1	14.0 V	64 Steps	15.0 V	Ta = 25°C 1/9 bias
1	0	13.0 V		14.0 V	
0	1	12.0 V		13.0 V	
0	0	11.0 V		12.0 V	

(Note): The VLC0 voltage is derated with respect to temperature by 0%/°C of centigrade in the range of minimum to maximum values. Therefore, voltage fluctuations due to temperature may be depicted like the one shown below.



• About display RAM area

The T6K11's display RAM has a row of 160 cells in the segment direction and a row of 65 cells in the common direction, together constituting 10, 400 bits of memory capacity. The relationship between the dot matrix LCD (= display screen) and the display RAM is such that one dot on the display screen corresponds to one bit in the display RAM as shown in Fig. 8. If the data written to the display RAM is a logic 1, the corresponding dot on the display screen is turned on (black) ; if the data is a logic 0, the corresponding dot on the display screen is turned off (white). The relationship between display RAM and dot matrix LCD is shown below.

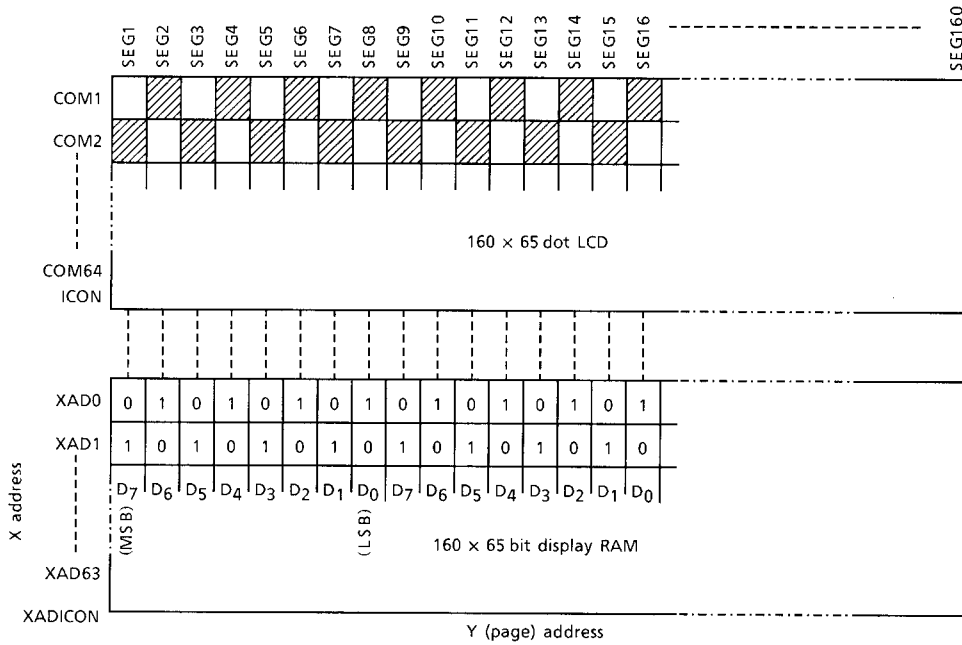

Fig. 8

Note that if a duty cycle other than 1 / 64 is selected and a Z-address other than ZAD = 00h is set, the effective display RAM area is moved. The table below shows the relationship between duty cycle and Z-address settings and the resulting RAM area.

Duty Setting	Effective Ram Area		Range of XAD when Z-Address is set to 00h	Range of XAD when Z-Address is set to 05h	Remark
	Segment Direction	Common Direction			
1 / 35 duty	160 lines	35 lines	XAD = C0~E1h, 80h	XAD = C5~E6h, 80h	
1 / 49 duty	160 lines	49 lines	XAD = C0~EFh, 80h	XAD = C5~F4h, 80h	
1 / 55 duty	160 lines	55 lines	XAD = C0~F5h, 80h	XAD = C5~FAh, 80h	
1 / 65 duty	160 lines	65 lines	XAD = C0~FFh, 80h	XAD = C5~C4h, 80h	(Note 1)

Note 1: Even when ZAD is set to any value other than 00h, the effective display RAM area is the full size, so that the range of XAD is the same as XAD = C0 to FFh and 80h shown above. Here, XADICON is expressed as 80h. For details about the specification of XADICON, refer to the command description (R4) on page 20. The Z-address is effective in the range of XAD0 to 63 and does not affect XADICON.

**Page Configuration of Display RAM**

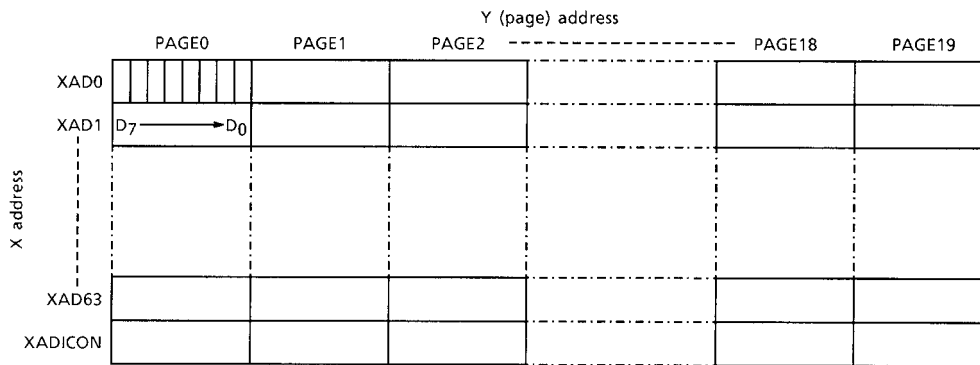

**Fig. 9**

**Command Definition**

Command	Reg No.	RS	/WR	/RD	DB7	DB6	DB5	DB4	DB3	DB2	DB1	DB0
Set Register (REG)	—	0	0	1	*	*	*	*	Register (0 to 15)			
Status Read (STRD)	—	0	1	0	*	*	*	*	RST	N / F	X / Y	U / D
Display Mode (DPE)	R0	1	0	1	*	*	*	*	CDR	SDR	D / F	DP
Counter Mode (CSE)	R1	1	0	1	*	*	*	*	*	*	X / Y	U / D
Analog Control Mode (APE)	R2	1	0	1	CDA	DC	*	*	BIAS (0 to 3)		DUTY (0 to 3)	
Alternating Signal Mode (FRS)	R3	1	0	1	*	*	FRS control (0 to 63)					
Set Y-address (SYE)	R4	1	0	1	0	*	*	Y-address (0 to 19)				
Set X-address (SXE)		1	0	1	1	N / F	X-address (0 to 63)					
Set Z-address (SZE)	R5	1	0	1	*	*	Z-address (0 to 63)					
Contrast Control (SCE)	R6	1	0	1	VLC0 control	Contrast control (0 to 63)						
Data Write (DAWR)	R7	1	0	1	Write data							
Data Read (DARD)		1	1	0	Read data							
D/A Converter Power Control (OPC)	R12	1	0	1	ON/OFF	*	fCDA	OC	Bias Current Control (0 to 15)			
Test Mode (TEST)	R8 to 11 R13 to 15	1	0	1	Test mode (Do not access these registers)							

● **Set register (REG)**

RS	/WR	/RD	DB7	DB6	DB5	DB4	DB3	DB2	DB1	DB0
0	0	1	*	*	*	*	Register (0 to 15)			

This command selects a register No. When data is input after executing this command, the data is written to the register.

● **R0: Display mode (DPE)**

RS	/WR	/RD	DB7	DB6	DB5	DB4	DB3	DB2	DB1	DB0
1	0	1	*	*	*	*	CDR	SDR	N/F	DP

This command sets a display mode. When data is input after executing this command, the contents shown below are set.

CDR: Sets the common data scanning direction.

CRD = 0: Data is scanned in the direction ICON → COM64 → COM1.

CRD = 1: Data is scanned in the direction COM1 → COM64 → ICON.

SDR: Sets the segment data direction.

SDR = 0: SEG1 → SEG160 with respect to the data direction DB7 → DB0

SDR = 1: SEG1 → SEG160 with respect to the data direction DB0 → DB7

N/F: Selects between normal display and icon display modes.

N/F = 0 : Icon display mode is selected.

N/F = 1 : Normal display mode is selected.

DP: Turns display ON or OFF.

DP = 0: Display is turned OFF.

DP = 1: Display is turned ON.

• **R<sub>1</sub>: Counter mode (CSE)**

RS	/WR	/RD	DB7	DB6	DB5	DB4	DB3	DB2	DB1	DB0
1	0	1	*	*	*	*	*	*	Y/X	U/D

This command sets a counter mode. When data is input after executing this command, the contents shown below are set.

DB1	DB0	
0	0	Y-counter/Down mode is selected.
0	1	Y-counter/Up mode is selected.
1	0	X-counter/Down mode is selected.
1	1	X-counter/Up mode is selected.

The X and Y counters count the X and Y addresses of the display RAM when reading or writing to the RAM. This command selects either X or Y counter and also determines whether the selected counter counts up or down. Only one of the four available modes can be selected.

● **R<sub>2</sub>: Set analog control mode (APE)**

RS	/WR	/RD	DB7	DB6	DB5	DB4	DB3	DB2	DB1	DB0
1	0	1	CDA	DC	*	*	BIAS (0 to 3)		DUTY (0 to 3)	

This command selects analog control and sets bias and duty cycle. When data is input after executing this command, the contents shown below are set.

CDA : Turns the D/A converter for the LCD drive power supply ON or OFF.

CDA = 0 : The D/A converter is turned OFF.

CDA = 1 : The D/A converter is turned ON.

DC : Turns the step-up circuit on or off.

DC = 0 : The step-up circuit is turned OFF.

DC = 1 : The step-up circuit is turned ON.

BIAS: Sets a power supply bias for the LCD drive.

DB3	DB2	
0	0	Set to 1/6 bias.
0	1	Set to 1/7 bias.
1	0	Set to 1/8 bias.
1	1	Set to 1/9 bias.

DUTY: Sets a display duty cycle.

DB1	DB0	
0	0	Set to 1/35 duty.
0	1	Set to 1/49 duty.
1	0	Set to 1/57 duty.
1	1	Set to 1/65 duty.

(Note): The T6K11's COM output which corresponds to the line of LCD is changed by the Duty.  
When CDR = 1, COM outputs in each Duty are shown below.

1/n duty	LCD	1 <sup>st</sup> line, 2 <sup>nd</sup> line,....., n <sup>th</sup> line, ICON
1/35 duty		COM1, COM2,.....,COM17, COM33, COM34,.....,COM49, ICON
1/49 duty		COM1, COM2,.....,COM24, COM33, COM34,.....,COM56, ICON
1/57 duty		COM1, COM2,.....,COM28, COM33, COM34,.....,COM60, ICON
1/65 duty		COM1, COM2,.....,COM32, COM33, COM34,.....,COM64, ICON



● **R<sub>3</sub>: Set alternating signal mode (APE)**

RS	/WR	/RD	DB7	DB6	DB5	DB4	DB3	DB2	DB1	DB0
1	0	1	*	*	FRS CONTROL (0 to 63)					

This command sets a number of lines at which the alternating signal (FR) should be inverted every time. When data is input after executing this command, the contents shown below are set.

FRS = 0: A 1/m (\*1) duty is selected according to the DUTY that is set in the R<sub>2</sub> register and the alternating signal (FR) is inverted at a number of lines equal to the selected duty cycle.

FRS ≠ 0: The alternating signal (FR) is inverted at a number of lines that equals the written data + 1.

\*1: This is one of 1/35 duty, 1/49 duty, 1/57 duty, or 1/65 duty.

● **R<sub>4</sub>: Set Y-address (SYE)**

RS	/WR	/RD	DB7	DB6	DB5	DB4	DB3	DB2	DB1	DB0
1	0	1	0	*	*	Y-ADDRESS (0 to 19)				

This command sets a Y-address which is comprised of 20 pages. One of these pages is selected as data is written to the display RAM. When reset, the Y-address is set to page 0.

**Set X-address (SXE)**

RS	/WR	/RD	DB7	DB6	DB5	DB4	DB3	DB2	DB1	DB0
1	0	1	1	N/F	X-ADDRESS (0 to 63)					

This command sets an X-address by selecting between display RAM and flag (icon) RAM. Address selection between display RAM and flag (icon) RAM is controlled by the data in DB7. When N/F = 1, the display RAM is selected. In this case, the low-order data (DB0 to DB5) are identified as X-address, and an X-address can be selected from addresses 0 through 63. When N/F = 0, the flag (icon) RAM address (64) is selected irrespective of the low-order data (DB0 to DB5). When reset, the X-address is set to address 0 in the display RAM.

● **R<sub>5</sub>: Set Z-address (SZE)**

RS	/WR	/RD	DB7	DB6	DB5	DB4	DB3	DB2	DB1	DB0
1	0	1	*	*	Z-ADDRESS (0 to 63)					

This command sets a Z-address. The display RAM and flag (icon) RAM are separated and only the display RAM is selected. By selecting any address in the column direction of the display RAM, it is possible to set the first line on the LCD screen. The display data can be scrolled in the vertical direction by setting the first line in this way.

For example, if the Z-address is set to 20, the first line on the LCD screen corresponds to Z-address 20 in the display RAM, and the last line on the LCD screen corresponds to Z-address 19 in the display RAM. When reset, the Z-address is set to address 0.

● **R<sub>6</sub>: Contrast control (SCE)**

RS	/WR	/RD	DB7	DB6	DB5	DB4	DB3	DB2	DB1	DB0
1	0	1	VLC0 CONTROL		CONTRAST CONTROL (0 to 63)					

This command sets VLC0 voltage adjustment resistance ratio and contrast control. These two controls adjust the density of display on the LCD screen. The density of display can be selected from 4 × 64 steps, where 00H is the lightest, and FFH the darkest. When reset, contrast control is set to 00H.

● **R<sub>7</sub>: Data write (DAWR) / data read (DARD)**

RS	/WR	/RD	DB7	DB6	DB5	DB4	DB3	DB2	DB1	DB0
1	0	1	WRITE DATA							
1	1	0	READ DATA							

These commands enable data write and read to and from the display RAM. This single command register R7 manages both data write and read to and from the display RAM. To write display data into the display RAM, set the X and Y addresses of the display RAM, then select this register (R7) and write the data to the selected addresses of the display RAM. To read data from the display RAM, set the X and Y addresses of the display RAM, then select this register (R7) and place it in the read mode (/RD = 0).

● **R<sub>12</sub>: D/A converter power control (OPC)**

RS	/WR	/RD	DB7	DB6	DB5	DB4	DB3	DB2	DB1	DB0
1	0	1	ON/OFF	*	fCDA	OC	BIAS CURRENT CONTROL (0 to 15)			

This command selects D/A converter power control and sets bias current control.

**ON/OFF:** Turns the power control circuit of the D/A converter ON or OFF.

ON/OFF = 0 : The power control circuit is turned OFF.

ON/OFF = 1 : The power control circuit is turned ON. When data is input after executing this command, the contents shown below are set.

**fCDA:** Sets an operating frequency of the D/A converter.

fCDA = 0 : Set to 1280 Hz.

fCDA = 1 : Set to 640 Hz.

**OC:** Turns the D/A converter offset voltage compensation circuit ON or OFF.

OC = 0 : The offset voltage compensation circuit is turned OFF.

OC = 1 : The offset voltage compensation circuit is turned ON.

**Bias Current Control:** This command controls the bias current of the D/A converter.

This command selects one of 16 levels.

When DB0 to DB3 are all 1, the bias current is set to maximum value.

When DB0 to DB3 are all 0, the bias current is set to minimum value.

When reset, this register contents are set to 94 H by default.

fCDA = 0, OC = 1, Bias Current Control = 0100 (bin).

If the power control circuit is turned OFF, the contents except ON/OFF (DB7) are initialized.

● **R<sub>8</sub> to R<sub>15</sub>, R<sub>13</sub> to R<sub>15</sub>: Test mode (TEST)**

RS	/WR	/RD	DB7	DB6	DB5	DB4	DB3	DB2	DB1	DB0
1	0	1	WRITE DATA							

These command registers are provided for test. Do not choose these registers.

**Functional Description**

• **About the X-address and Y-address counters**

The following explains the operation of the X-address and Y-address counters in connection with each command. A typical operation of the X-address counter is shown in Fig. 10

After a reset, the X-address (XAD) is set to 0 and the X-counter / Up mode is selected by the command CSE. Next, the X-address is set to 62 by the command SXE. Then when data is read or written to the display RAM, the X-address counter is automatically incremented as it continues counting up.

When data is read or written at XAD = 63, the X-address is recycled to 0. Now the X-address / Down mode is selected by the command CSE. Then when data is read or written to the display RAM, the X-address counter is automatically decremented as it continues counting down. When data is read or written at XAD = 0, the X-address is recycled to 63.

The command CSE is effective for either X or Y counter selected. In the example here, the X-address counter is selected by CSE, so the Y-address counter does not count.

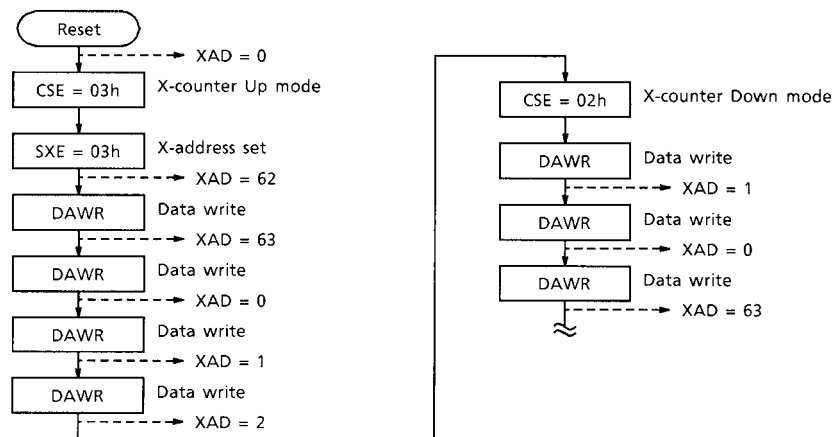

**Fig. 10**

Fig. 11 shows a typical operation of the Y (page) –address counter. After a reset, the Y (page) –address (YAD) is set to 0 and the Y (page) –counter / Up mode is selected by the command CSE. Then when data is read or written to the display RAM, the Y (page) –address counter is incremented. When data is read or written at YAD = 19, the Y (page) –address is recycled to 0. Similarly, if the Y (page) Down mode is selected by the command CSE, the Y (page) –address is automatically decremented as the counter continues counting down. When data is read or written at YAD = 0, the Y (page) –address is recycled to 19. In the example here, the Y (page) –address counter is selected by CSE, so the X–address counter does not count.

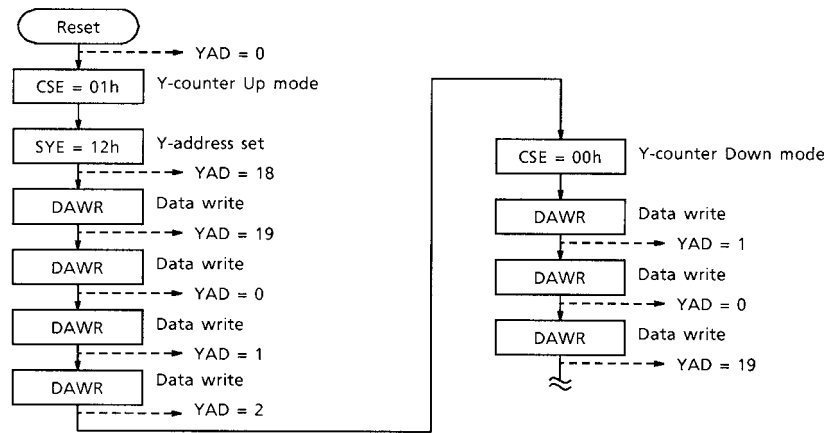

Fig. 11

• Data read

When executing Data Read, the T6K11 directly accesses the display RAM addresses to read out data. Therefore, when the Data Read command is executed after setting the X and Y addresses, data is output immediately from the display RAM.

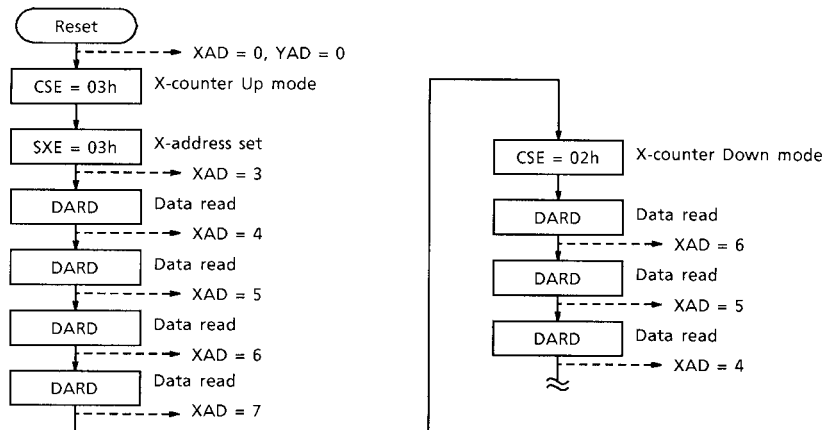
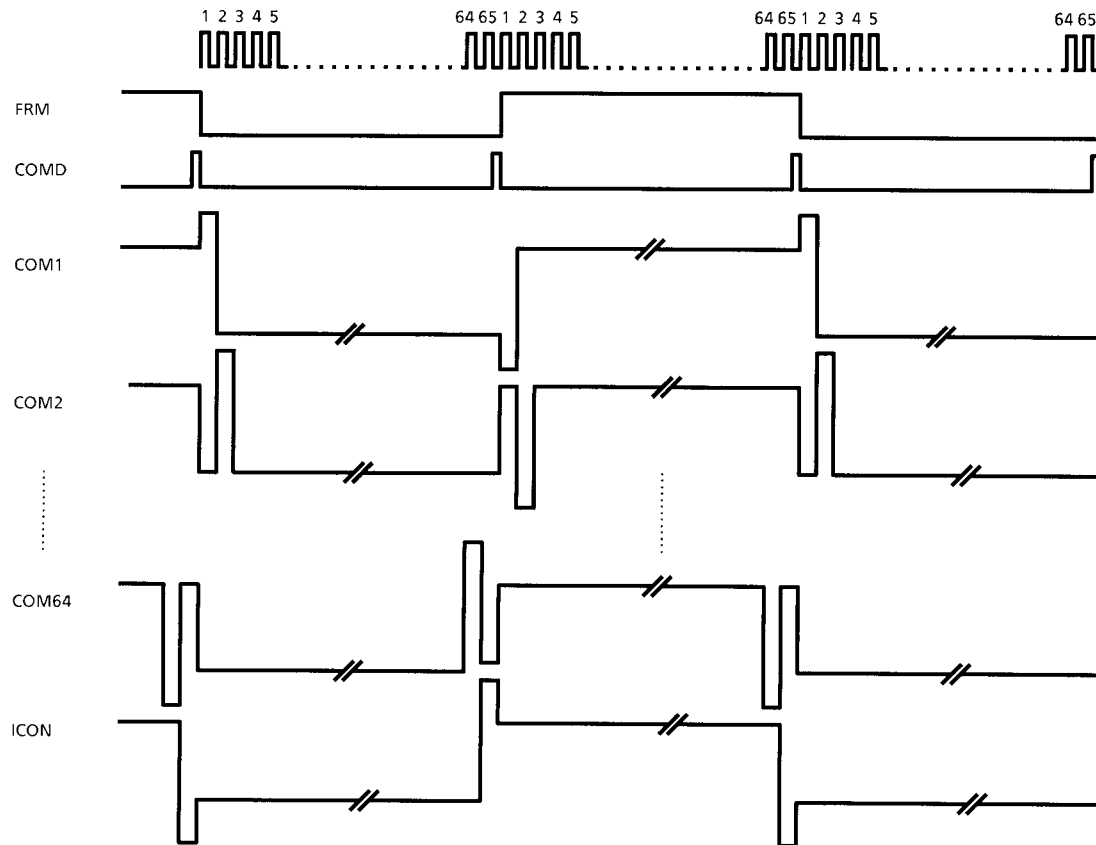

Fig. 12

• **FRS control**

The T6K11 has a command FRS that allows you to choose a number of lines at which the alternating signal (FR) is inverted every time. The T6K11's alternating signal can be inverted in the range of two lines up to the same number of lines as the duty cycle. Normally, 00H may be selected for the FRS command, so that the FR signal is inverted when the same number of lines as the duty cycle are latched every time. To obtain better display quality, FRS need to be adjusted to match the characteristics of each type of LCD panel used.

(a) For 1 / 65 duty and FRS = 00H (inverted at 64 + 1 lines)



**Fig. 13**

(b) For 1 / 35 and FRS = 10H (inverted at 16 + 1 lines)

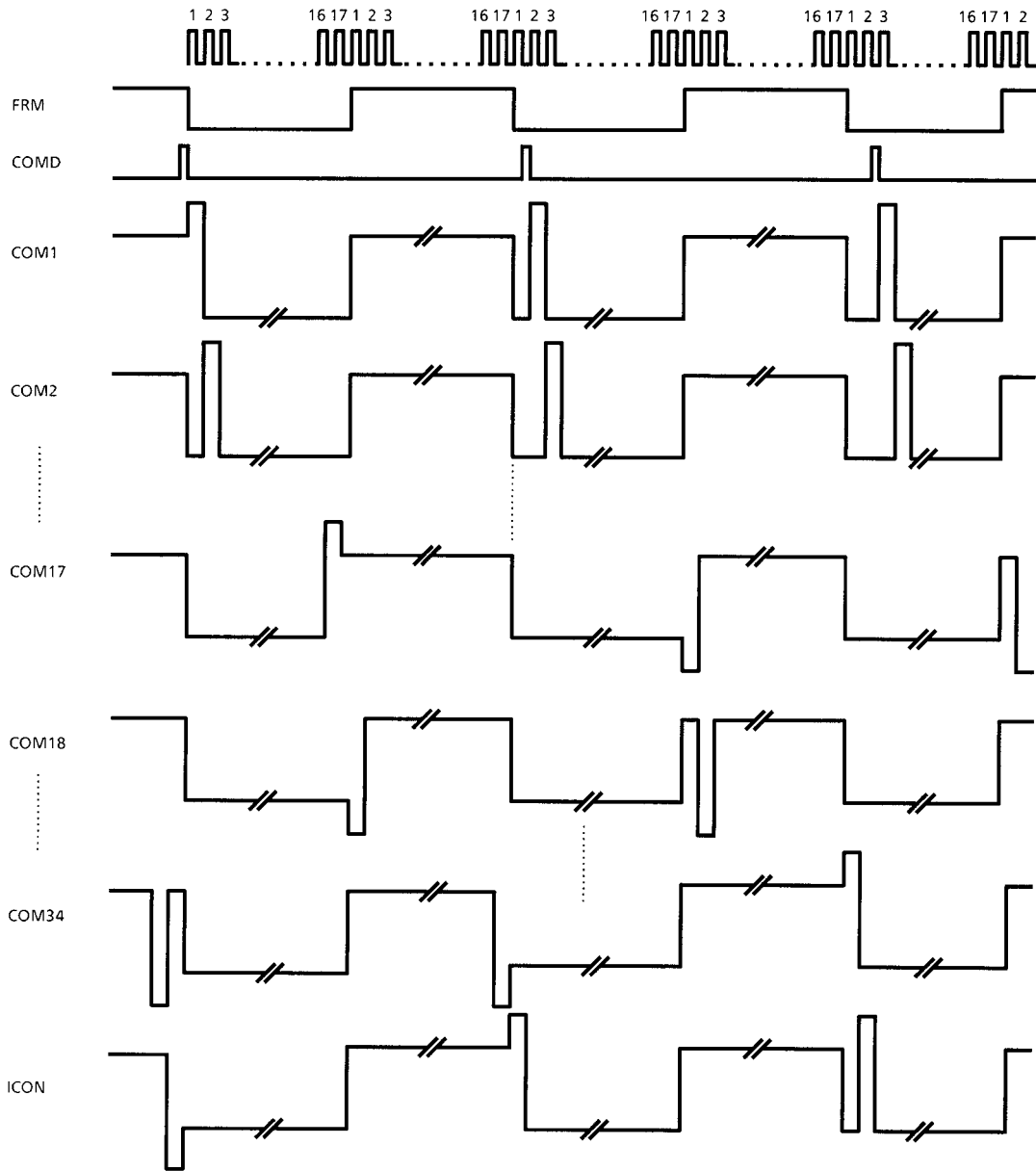

Fig. 14

● **Standby function**

The T6K11 has a /STB pin. When input to this pin is pulled low, the T6K11 enters a standby state. In this state, the CR circuit clock driver is deactivated and the device is placed in a Low Power mode to suppress current consumption. Even when the T6K11 is in standby state (the CR circuit is deactivated, so is the LCD display clock), it can be communicated from the MPU. Since data read/write operations are possible while the display is turned off, this helps to reduce current consumption.

In standby state, all of the LCD drive power supply pins VLC0 to VLC5 are tied to the VSS level.

When the standby function is used, the data in the display RAM is the display data that has been stored in it before the standby function is turned on.

Function	Oscillator	LCD Drive Power Supply	LCD Drive Output
Normal state	Operable	Operable	Operable
Standby state	Deactivated	Fixed to V <sub>SS</sub> level	Fixed to V <sub>SS</sub> level

● **Reset function**

The T6K11 has a /RST pin. When input to this pin is pulled low, the T6K11 is reset, with its internal circuits (register contents) initialized as shown below.

- (1) Display direction ..... CDR = 1, SDR = 1
- (2) Display mode ..... Normal display mode
- (3) Display ..... Turned OFF
- (4) Counter ..... Y-counter, Up mode
- (5) Analog control ..... CDA = 0, DC = 0
- (6) Bias ..... 1/9 bias
- (7) Duty cycle ..... 1/65 duty
- (8) Alternating signal (FR) ..... FRS = 00H  
(FR inverted at the same number of lines as the duty cycle)
- (9) Contrast ..... 00H (lightest)

The T6K11 does not have a facility to reset the display RAM (to clear the data in it). In the initial state (immediately after power-ON), the display RAM contains indeterminate data which are either high or low. Therefore, Toshiba recommends using the Data Write command to execute a display clearing sequence before reading or writing to the display RAM.

- Oscillation frequency**

The T6K11 contains a CR oscillator. The T6K11's frame frequency ( $f_{FR}$ ) is derived from the CR circuit's oscillation frequency ( $f_{OSC}$ ) by dividing it an appropriate value. The relationship between the oscillation frequency ( $f_{OSC}$ ) and the frame frequency ( $f_{FR}$ ) is shown below.

Duty Cycle	FRS Selection	Oscillation Frequency ( $f_{OSC}$ )	CL Frequency	$f_{FR}$ Frequency
1 / 65duty	Inverted at duty	41 kHz	$\frac{f_{OSC}}{8}$	$\frac{f_{OSC}}{8 \times 65}$
1 / 57duty	Inverted at duty	41 kHz	$\frac{f_{OSC}}{10}$	$\frac{f_{OSC}}{10 \times 57}$
1 / 49duty	Inverted at duty	41 kHz	$\frac{f_{OSC}}{12}$	$\frac{f_{OSC}}{12 \times 49}$
1 / 35duty	Inverted at duty	41 kHz	$\frac{f_{OSC}}{16}$	$\frac{f_{OSC}}{16 \times 35}$
1 / 65duty	Inverted at 17 lines	41 kHz	$\frac{f_{OSC}}{8}$	$\frac{f_{OSC}}{8 \times 17}$
1 / 2duty	Inverted at 2 lines	41 kHz	$\frac{f_{OSC}}{256}$	$\frac{f_{OSC}}{256 \times 2}$

Note: The T6K11 has its  $f_{FR}$  frequency varied by the FRS setup data. Therefore, consider the relationship between the duty cycle and the number of inversion lines when you adjust the  $f_{FR}$  frequency to suit the CD panel used.

- The relationship between bias control and contrast control**

The contrast adjustment range of VLC0 is varied according to the BIAS that is set in the R2 register and VLC0 CONTROL that is set in the R6 register.

So, it is necessary to control these registers when you adjust the VLC0 output voltage to suit the LCD panel used.

The relationship between the BIAS and the VLC0 output voltage is shown below.

Display mode	R6: VLC0 control		VLC0 output voltage (V)			
	DB7	DB6	1/6 bias	1/7 bias	1/8 bias	1/9 bias
N/F = 1	1	1	9.33	10.89	12.45	14.00
	1	0	8.67	10.11	11.55	13.00
	0	1	8.00	9.33	10.67	12.00
	0	0	7.34	8.56	9.78	11.00
N/F = 0	1	1	3.33	3.89	4.55	5.00
	1	0	3.25	3.79	4.33	4.87
	0	1	3.15	3.67	4.20	4.72
	0	0	3.04	3.55	4.05	4.56

(Note): The VLC0 output voltage values are typical values at max contrast.



• LCD drive waveform

(a) For normal display mode where duty cycle = 1/65 and FRS = 00h

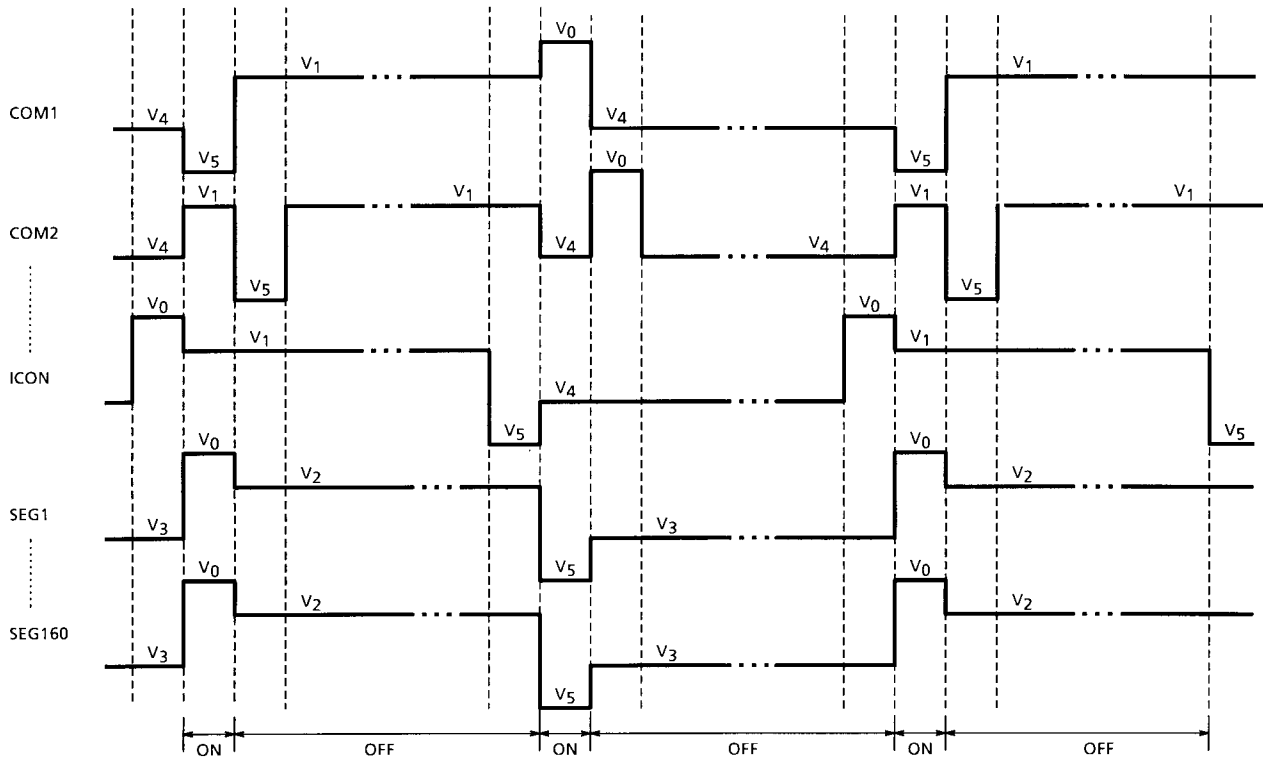

**Fig. 15**

(b) For power save mode where duty cycle = 1/2

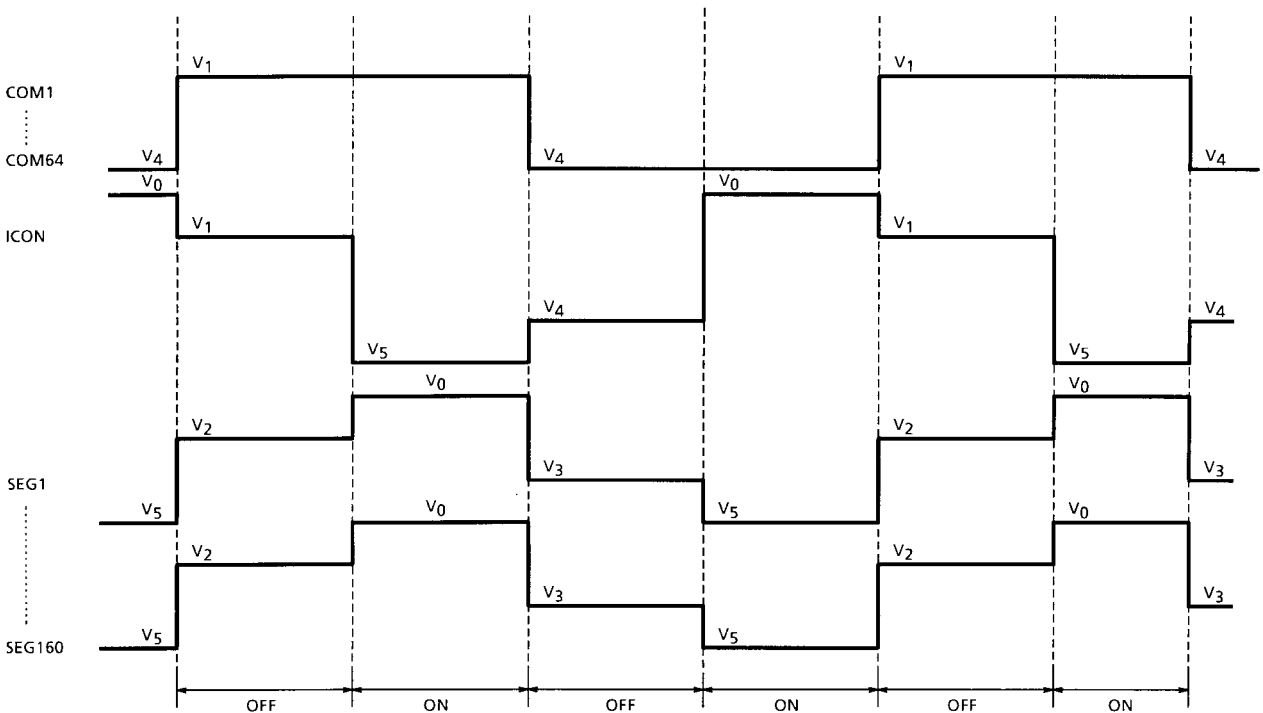

**Fig. 16**

**Maximum Ratings (Referenced to  $V_{SS} = 0$  V,  $T_a = 25^\circ\text{C}$  unless otherwise noted)**

Characteristics	Symbol	Rating	Unit	Remark
Power Supply Voltage (1)	$DV_{DD}$ , $AV_{DD}$	$-0.3 \sim V_{SS} + 7.0$	V	(Note 1)
Power Supply Voltage (2)	(Note 2)	$-0.3 \sim V_{SS} + 18.0$	V	(Note 1), (Note 3)
Input Voltage (1)	$V_{INA}$	$-0.3 \sim AV_{DD} + 0.3$	V	(Note 1), (Note 4)
Input Voltage (2)	$V_{IND}$	$-0.3 \sim DV_{DD} + 0.3$	V	(Note 1), (Note 4)
Output Voltage (1)	$V_{OA}$	$-0.3 \sim V_{SS} + 18.0$	V	(Note 1)
Output Voltage (2)	$V_{OD}$	$-0.3 \sim DV_{DD} + 0.3$	V	(Note 1)
Operating Temperature	$T_{opr}$	$-25 \sim 75$	$^\circ\text{C}$	—
Storage Temperature	$T_{stg}$	$-40 \sim 125$	$^\circ\text{C}$	—

Note 1: These values are referenced to  $AV_{SS} = DV_{DD} = 0$  V.

Note 2:  $V_{CC}$ ,  $V_{LC0}$ ,  $V_{LC1}$ ,  $V_{LC2}$ ,  $V_{LC3}$ ,  $V_{LC4}$ ,  $V_{LC5}$

Note 3: The condition  $V_{CC} \geq V_{LC0} \geq V_{LC1} \geq V_{LC2} \geq V_{LC3} \geq V_{LC4} \geq V_{LC5} \geq$  must always be met.

Note 4: The condition  $AV_{DD} \geq DV_{DD}$  must always be met.

Note 5: If the device is used exceeding its absolute maximum ratings, the device may not only break down but also loose reliability and malfunction. Therefore, Toshiba recommends that for normal operation, the device be used within the range of electrical characteristics shown in the next page.

## Electrical Characteristics

**DC Characteristics (1) referenced to  $DV_{DD} = 3.0\text{ V}$ ,  $AV_{DD} = 3.0\text{ V}$ ,  $V_{SS} = 0\text{ V}$ ,  $V_{CC} = 15.0\text{ V}$ ,  $V_{LC0} = 14.0\text{ V}$ ,  $T_a = -20\text{ to }60^\circ\text{C}$  unless otherwise noted**

Characteristics		Symbol	Test Circuit	Test Condition	Min	Typ.	Max	Unit	Relevant Pin
Operating Voltage (1)		$AV_{DD}$	—	—	$DV_{DD}$	3.0	5.5	V	$AV_{DD}$
Operating Voltage (2)		$DV_{DD}$	—	—	1.8	3.0	3.3	V	$DV_{DD}$
Operating Voltage (3)		$V_{CC}$ $V_{CL0}$	—	—	$6.0 - V_{SS}$	—	$16.5 - V_{SS}$	V	$V_{CC}$ , $V_{CL0}$
Input Voltage	High Level	$V_{IH}$	—	—	$0.80 \times DV_{DD}$	—	$DV_{DD}$	V	(Note 1)
	Low Level	$V_{IL}$	—	—	0	—	$0.20 \times DV_{DD}$	V	
Output Voltage	High Level	$V_{OH}$	—	$I_{OH} = -400\ \mu\text{A}$	$DV_{DD} - 0.2$	—	$DV_{DD}$	V	DB0 to DB7
	Low Level	$V_{OL}$	—	$I_{OL} = 400\ \mu\text{A}$	0	—	0.2	V	
Segment Driver ON-Resistance	Normal Mode	$R_{col1}$	—	(Note 2)	—	—	7.5	k $\Omega$	SEG1 to SEG160
	Power Save Mode	$R_{col2}$	—	(Note 3)	—	—	15.0	k $\Omega$	
Common Driver ON-Resistance	Normal Mode	$R_{row1}$	—	(Note 2)	—	—	1.5	k $\Omega$	COM1 to COM64 ICON
	Power Save Mode	$R_{row2}$	—	(Note 3)	—	—	5.0	k $\Omega$	
Input Leakage Current		$I_{IL}$	—	$V_{IND} = DV_{DD}$ to GND	-1	—	1	$\mu\text{A}$	(Note 1)
Output Leakage Current		$I_{OL}$	—	$V_{OD} = DV_{DD}$ to GND	-1	—	1	$\mu\text{A}$	DB0 to DB7

Note 1: This applies to pins DB0 through DB7, RS, /MR, /RD, /CS1, CS2, /RST, /STB, P/S, 68/80, and CLS.

Note 2: Referenced to  $AV_{DD} = 3.0\text{ V}$ ,  $DV_{DD} = 3.0\text{ V}$ ,  $V_{LC0} = 11.0\text{ V}$ ,  $V_{CC} = 16.5\text{ V}$ , 1/9 bias, current load  $I_{load} = 100\ \mu\text{A}$ ,  $T_a = 25^\circ\text{C}$ .

Note 3: Referenced to  $AV_{DD} = 3.0\text{ V}$ ,  $DV_{DD} = 3.0\text{ V}$ ,  $V_{LC0} = 4.0\text{ V}$ ,  $V_{CC} = 6.0\text{ V}$ , 1/9 bias, current load  $I_{load} = 100\ \mu\text{A}$ ,  $T_a = 25^\circ\text{C}$ .

**DC Characteristics (2) referenced to  $DV_{DD} = 3.0\text{ V}$ ,  $AV_{DD} = 3.0\text{ V}$ ,  $V_{SS} = 0\text{ V}$ ,  $V_{CC} = 15.0\text{ V}$ ,  $V_{LC0} = 14.0\text{ V}$ ,  $T_a = -20\text{ to }60^\circ\text{C}$  unless otherwise noted**

Characteristics	Symbol	Test Circuit	Test Condition	Min	Typ.	Max	Unit	Relevant Pin
Operating Frequency (Input Frequency)	CLIN	—	—	—	41	—	kHz	CL
Output Frequency	CLO	—	—	39	41	43	kHz	CL
External Clock Frequency	Fex	—	—	39	41	43	kHz	CL
External Clock Duty Cycle	Fduty	—	—	45	50	55	%	CL
External Clock Rise / Fall Time	Tr / Tf	—	—	—	—	10	ns	CL

**DC Characteristics (3) referenced to  $DV_{DD} = 3.0\text{ V}$ ,  $AV_{DD} = 3.0\text{ V}$ ,  $V_{SS} = 0\text{ V}$ ,  $T_a = -20\text{ to }60^\circ\text{C}$  unless otherwise noted**

Characteristics	Symbol	Test Circuit	Test Condition	Min	Typ.	Max	Unit	Relevant Pin
Output Voltage Characteristic (Using $\times 2$ Step-up Circuit)	$V_{O1}$	(1)	(Note 4)	5.50	5.60	—	V	VOUT1
Output Voltage Characteristic (Using $\times 3$ Step-up Circuit)	$V_{O2}$	(2)	(Note 5)	8.33	8.55	—	V	VOUT2
Output Voltage Characteristic (Using $\times 4$ Step-up Circuit)	$V_{O3}$	(3)	(Note 6)	11.25	11.50	—	V	VOUT3
Output Voltage Characteristic (Using $\times 5$ Step-up Circuit)	$V_{O4}$	(4)	(Note 7)	14.15	14.40	—	V	VOUT4

Note 4: Referenced to  $DV_{DD} = AV_{DD} = 3.0\text{ V}$ ,  $I_{load} = 200\text{ }\mu\text{A}$ ,  $V_{CC} = 6.0\text{ V}$  (supplied from external source),  $C_{nA} - C_{nB} = 1.0\text{ }\mu\text{F}$ ,  $V_{OUTn} - V_{SS} = 1.0\text{ }\mu\text{F}$ ,  $CL = 41.0\text{ kHz}$ .

Note 5: Referenced to  $DV_{DD} = AV_{DD} = 3.0\text{ V}$ ,  $I_{load} = 200\text{ }\mu\text{A}$ ,  $V_{CC} = 9.0\text{ V}$  (supplied from external source),  $C_{nA} - C_{nB} = 1.0\text{ }\mu\text{F}$ ,  $V_{OUTn} - V_{SS} = 1.0\text{ }\mu\text{F}$ ,  $CL = 41.0\text{ kHz}$ .

Note 6: Referenced to  $DV_{DD} = AV_{DD} = 3.0\text{ V}$ ,  $I_{load} = 200\text{ }\mu\text{A}$ ,  $V_{CC} = 12.0\text{ V}$  (supplied from external source),  $C_{nA} - C_{nB} = 1.0\text{ }\mu\text{F}$ ,  $V_{OUTn} - V_{SS} = 1.0\text{ }\mu\text{F}$ ,  $CL = 41.0\text{ kHz}$ .

Note 7: Referenced to  $DV_{DD} = AV_{DD} = 3.0\text{ V}$ ,  $I_{load} = 200\text{ }\mu\text{A}$ ,  $V_{CC} = 15.0\text{ V}$  (supplied from external source),  $C_{nA} - C_{nB} = 1.0\text{ }\mu\text{F}$ ,  $V_{OUTn} - V_{SS} = 1.0\text{ }\mu\text{F}$ ,  $CL = 41.0\text{ kHz}$ .

**DC Characteristics (4) referenced to  $DV_{DD} = 3.0\text{ V}$ ,  $AV_{DD} = 3.0\text{ V}$ ,  $V_{SS} = 0\text{ V}$ ,  $T_a = -20\text{ to }60^\circ\text{C}$  unless otherwise noted**

Characteristics	Symbol	Test Circuit	Test Condition	Min	Typ.	Max	Unit	Relevant Pin
Current Consumption (1)	ISS1	—	(Note 8)	—	235	315	$\mu\text{A}$	$V_{SS}$
Current Consumption (2)	ISS1	—	(Note 9)	—	250	360	$\mu\text{A}$	$V_{SS}$
Current Consumption (3)	ISS3	—	(Note 10)	—	470	500	$\mu\text{A}$	$V_{SS}$
Current Consumption (4)	ISS4	—	(Note 11)	—	40	45	$\mu\text{A}$	$V_{SS}$
Current Consumption (5)	ISSSTB	—	(Note 12)	—	—	1	$\mu\text{A}$	$V_{SS}$

Note 8: Referenced to  $AV_{DD} = DV_{DD} = 3.0\text{ V}$ ,  $AV_{SS} = DV_{SS} = 0\text{ V}$ ,  $V_{CC} = V_{OUT4}$  (using  $\times 5$  step-up), internal CR oscillator turned on (CL = 41 kHz), 1/9 bias, 1/65 duty, D/A converter turned on, LCD nonloaded, display pattern: all "white," no data access, normal display mode, contrast control: R5 = BFH, VLC0 = 13.0 V,  $T_a = 25^\circ\text{C}$ , FRS = 0H.

Note 9: Referenced to  $AV_{DD} = DV_{DD} = 3.0\text{ V}$ ,  $AV_{SS} = DV_{SS} = 0\text{ V}$ ,  $V_{CC} = V_{OUT4}$  (using  $\times 5$  step-up), internal CR oscillator turned on (CL = 41 kHz), 1/9 bias, 1/65 duty, D/A converter turned on, LCD nonloaded, display pattern: "checker," no data access, normal display mode, contrast control: R5 = BFH, VLC0 = 13.0 V,  $T_a = 25^\circ\text{C}$ , FRS = 0H.

Note 10: Referenced to  $AV_{DD} = DV_{DD} = 3.0\text{ V}$ ,  $AV_{SS} = DV_{SS} = 0\text{ V}$ ,  $V_{CC} = V_{OUT4}$  (using  $\times 5$  step-up), internal CR oscillator turned on (CL = 41 kHz), 1/9 bias, 1/65 duty, D/A converter turned on, LCD nonloaded, display pattern: "checker," data access performed ( $f_{CE} = 1\text{ MHz}$ ), normal display mode, contrast control: R5 = BFH, VLC0 = 13.0 V,  $T_a = 25^\circ\text{C}$ , FRS = 0H.

Note 11: Referenced to  $AV_{DD} = DV_{DD} = 3.0\text{ V}$ ,  $AV_{SS} = DV_{SS} = 0\text{ V}$ ,  $V_{CC} = V_{OUT4}$  (using  $\times 5$  step-up), internal CR oscillator turned on (CL = 41 kHz), 1/9 bias, 1/2 duty, D/A converter turned on, LCD nonloaded, display pattern: "checker," no data access, power save mode.

Note 12: Referenced to  $AV_{DD} = DV_{DD} = 3.0\text{ V}$ ,  $AV_{SS} = DV_{SS} = 0\text{ V}$ ,  $V_{CC} = 16.5\text{ V}$ , LCD nonloaded, no data access.

**DC Characteristics (5) referenced to  $DV_{DD} = 3.0\text{ V}$ ,  $AV_{DD} = 3.0\text{ V}$ ,  $V_{SS} = 0\text{ V}$ ,  $T_a = 25^\circ\text{C}$  unless otherwise noted**

Characteristics	Symbol	Test Circuit	Test Condition	Min	Typ.	Max	Unit	Relevant Pin
VLC0 Output Voltage	V0out	—	$T_a = 25^\circ\text{C}$ (Note 13)	13.8	14.0	14.2	V	VLC0
		—	$T_a = 25^\circ\text{C}$ (Note 14)	12.8	13.0	13.2	V	VLC0
		—	$T_a = 25^\circ\text{C}$ (Note 15)	11.8	12.0	12.2	V	VLC0
		—	$T_a = 25^\circ\text{C}$ (Note 16)	10.8	11.0	11.2	V	VLC0
VLC0 Output Voltage Inclination	V0INC	—	$T_a = -20\text{ to }60^\circ\text{C}$ (Note 13)	-0.05	V0out	0.05	$\%/^\circ\text{C}$	VLC0

Note 13:  $AV_{DD} = DV_{DD} = 3.0\text{ V}$ ,  $AV_{SS} = DV_{SS} = 0\text{ V}$ , 1/65 duty, 1/9 bias,  $V_{CC} = 15.0\text{ V}$  (supplied from external source), CONTRAST CONTROL (R5) = FFh, D/A converter turned on, LCD nonloaded, normal display mode.

Note 14:  $AV_{DD} = DV_{DD} = 3.0\text{ V}$ ,  $AV_{SS} = DV_{SS} = 0\text{ V}$ , 1/65 duty, 1/9 bias,  $V_{CC} = 14.0\text{ V}$  (supplied from external source), CONTRAST CONTROL (R5) = BFh, D/A converter turned on, LCD nonloaded, normal display mode.

Note 15:  $AV_{DD} = DV_{DD} = 3.0\text{ V}$ ,  $AV_{SS} = DV_{SS} = 0\text{ V}$ , 1/65 duty, 1/9 bias,  $V_{CC} = 13.0\text{ V}$  (supplied from external source), CONTRAST CONTROL (R5) = 7Fh, D/A converter turned on, LCD nonloaded, normal display mode.

Note 16:  $AV_{DD} = DV_{DD} = 3.0\text{ V}$ ,  $AV_{SS} = DV_{SS} = 0\text{ V}$ , 1/65 duty, 1/9 bias,  $V_{CC} = 12.0\text{ V}$  (supplied from external source), CONTRAST CONTROL (R5) = 3Fh, D/A converter turned on, LCD nonloaded, normal display mode.

**DC Characteristics (6) referenced to  $DV_{DD} = 3.0\text{ V}$ ,  $AV_{DD} = 3.0\text{ V}$ ,  $V_{SS} = 0\text{ V}$ ,  
 $T_a = -20$  to  $60^\circ\text{C}$  unless otherwise noted**

Characteristics	Symbol	Test Circuit	Test Condition	Min	Typ.	Max	Unit	Relevant Pin
D/A Converter Output Voltage Offset (1)	Vopoff1	—	(Note 17, 21, 22)	-200	—	200	mV	(Note 20)
	Vopoff2	—	(Note 18, 21, 22)	-200	—	200	mV	(Note 20)
D/A Converter Output Voltage Offset (2)	Voffset1	—	$I_{Load} = \pm 20\ \mu\text{A}$	—	$\pm 50$	$\pm 80$	mV	VLC0, VLC2, VLC3
	Voffset2	—	$I_{Load} = \pm 3\ \mu\text{A}$	—	$\pm 30$	$\pm 50$	mV	VLC1, VLC4
D/A Converter Output Voltage Offset (3)	Vopoffs	—	(Note 19, 21, 22)	-200	—	200	mV	(Note 20)

Note 17: Referenced to  $AV_{DD} = DV_{DD} = 3.0\text{ V}$ ,  $AV_{SS} = DV_{SS} = 0\text{ V}$ , 1/65 duty, 1/9 bias,  $V_{CC} = 15.0\text{ V}$  (supplied from external source), contrast control = Max, D/A converter: ON, step-up circuit: OFF, LCD nonloaded, normal display mode.

VLC0 pin:  $14.0 - \text{VLC0} = \text{Vopoff1}$   
 VLC1 pin:  $(\text{VLC0} \times 8/9) - \text{VLC1} = \text{Vopoff1}$   
 VLC2 pin:  $(\text{VLC0} \times 7/9) - \text{VLC2} = \text{Vopoff1}$   
 VLC3 pin:  $(\text{VLC0} \times 2/9) - \text{VLC3} = \text{Vopoff1}$   
 VLC4 pin:  $(\text{VLC0} \times 1/9) - \text{VLC4} = \text{Vopoff1}$

Note 18: Referenced to  $AV_{DD} = DV_{DD} = 3.0\text{ V}$ ,  $AV_{SS} = DV_{SS} = 0\text{ V}$ , 1/2 duty, 1/9 bias,  $V_{CC} = 6.0\text{ V}$  (supplied from external source), contrast control = Max, D/A converter: ON, step-up circuit: OFF, LCD nonloaded, power save mode.

VLC0 pin:  $5.0 - \text{VLC0} = \text{Vopoff2}$   
 VLC1 pin:  $(\text{VLC0} \times 8/9) - \text{VLC1} = \text{Vopoff2}$   
 VLC2 pin:  $(\text{VLC0} \times 7/9) - \text{VLC2} = \text{Vopoff2}$   
 VLC3 pin:  $(\text{VLC0} \times 2/9) - \text{VLC3} = \text{Vopoff2}$   
 VLC4 pin:  $(\text{VLC0} \times 1/9) - \text{VLC4} = \text{Vopoff2}$

Note 19: Referenced to  $AV_{DD} = DV_{DD} = 3.0\text{ V}$ ,  $AV_{SS} = DV_{SS} = 0\text{ V}$ , 1/65 duty, 1/9 bias,  $V_{CC} = 15.0\text{ V}$  (supplied from external source), contrast control = Max, D/A converter: ON, step-up circuit: OFF, LCD nonloaded, normal display mode.

$\text{Vopoffs} = ((\text{VLC1} - \text{VLC2}) - (\text{VLC0} - \text{VLC1})) + ((\text{VLC3} - \text{VLC4}) - (\text{VLC4} - \text{VLC5}))$

Note 20: VLC0, VLC1, VLC2, VLC3 and VLC4.

Note 21: VLC0, VLC2, VLC3:  $I_{Load} = \pm 30\ \mu\text{A}$

Note 22: VLC1, VLC4:  $I_{Load} = \pm 3\ \mu\text{A}$

## Test Circuits

### (1) Test circuit for cases when ×2 step-up circuit is used

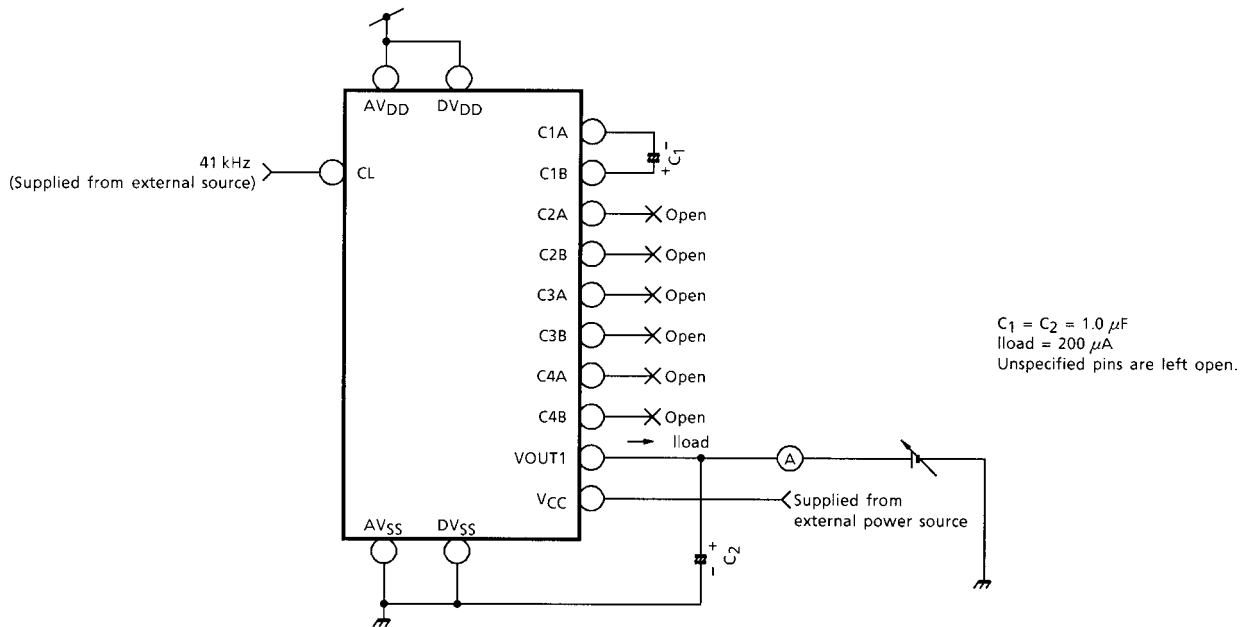

### (2) Test circuit for cases when ×3 step-up circuit is used

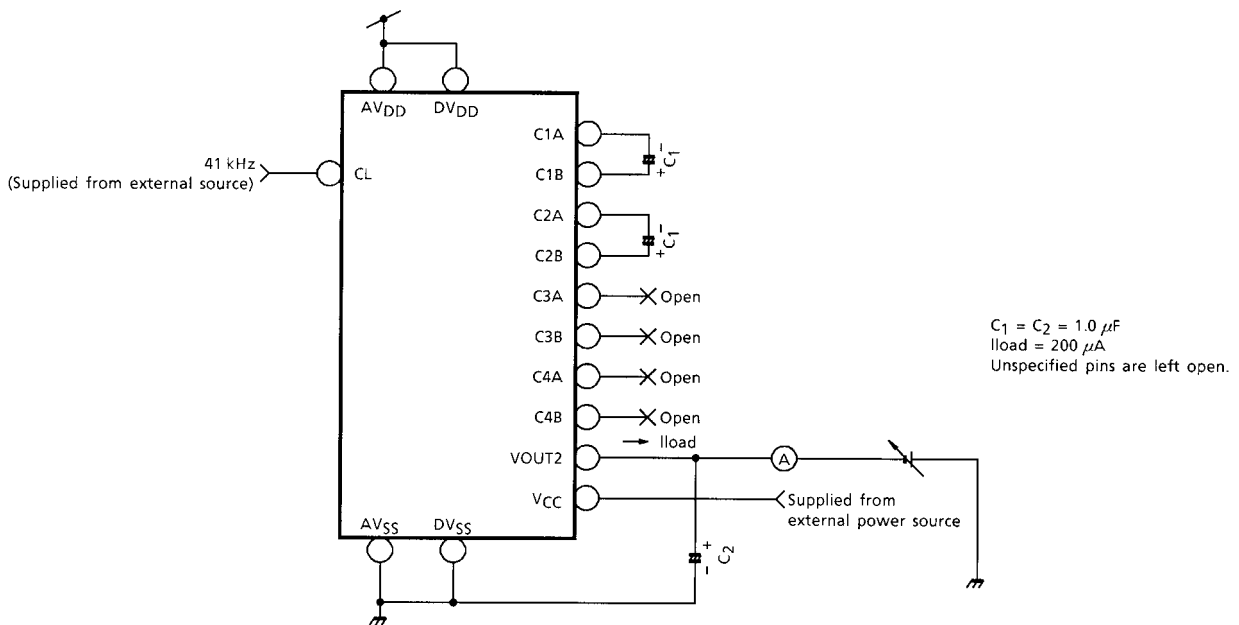

**(3) Test circuit for cases when ×4 step-up circuit is used**

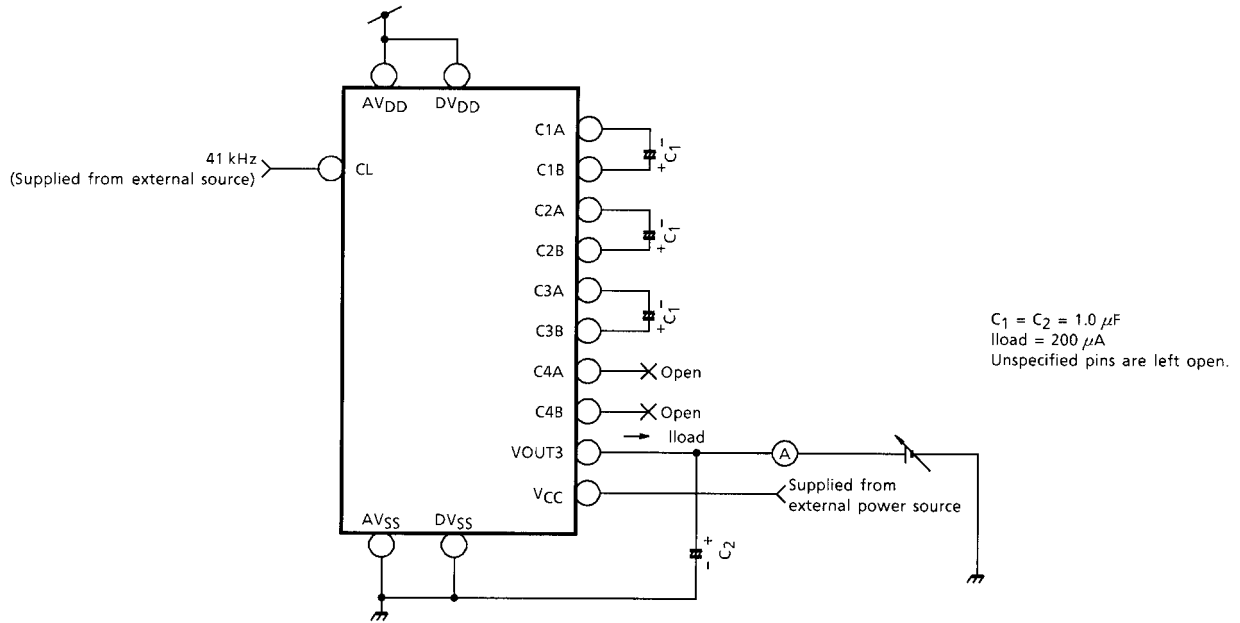

**(4) Test circuit for cases when ×5 step-up circuit is used**

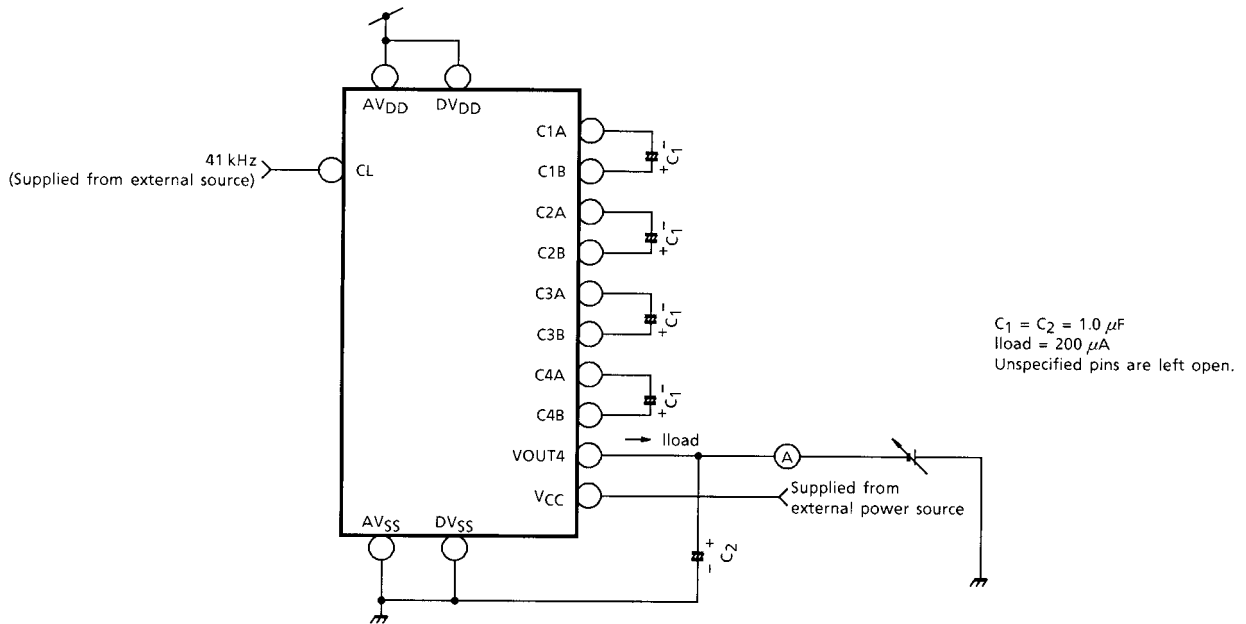



**AC Characteristics (1)**

- 80-series parallel interface read / write characteristics

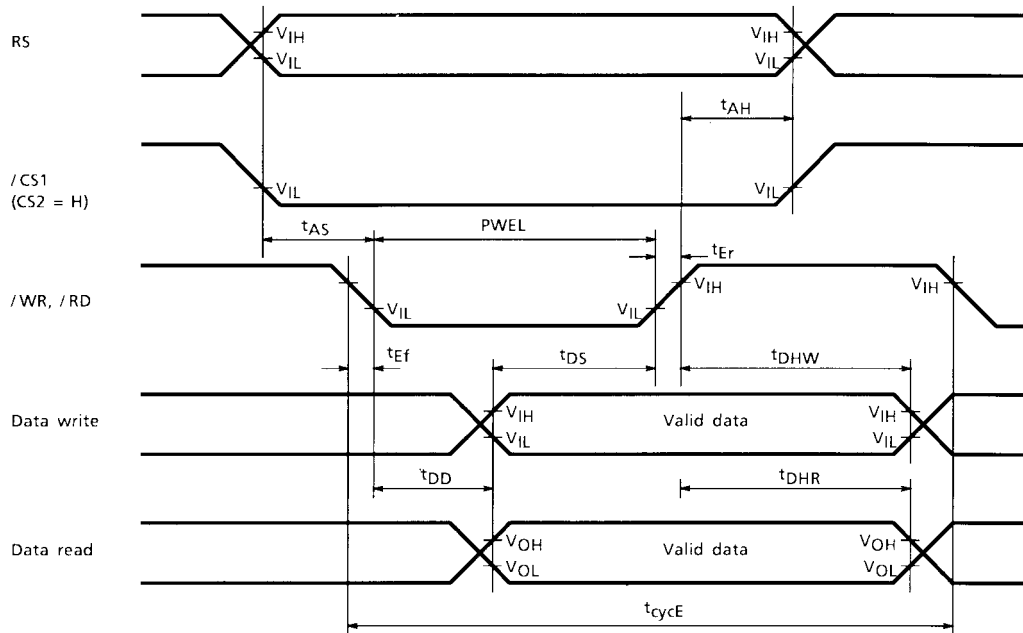

**Test Condition**

( Referenced to  $V_{SS} = 0\text{ V}$ ,  $DV_{DD} = AV_{DD} = 2.4\text{ to }2.7\text{ V}$ ,  
 $V_{CC} = AV_{DD}$ ,  $T_a = -20\text{ to }60^\circ\text{C}$  unless otherwise noted )

Characteristics	Symbol	Min	Max	Unit
Enable Cycle Time	$t_{cycE}$	1000	—	ns
Enable Pulse Width	$PWEL$	500	—	ns
Enable Rise / Fall Time	$t_{Er}, t_{Ef}$	—	20	ns
Address Setup Time	$t_{AS}$	25	—	ns
Address Hold Time	$t_{AH}$	25	—	ns
Data Setup Time	$t_{DS}$	130	—	ns
Write Data Hold Time	$t_{DHW}$	70	—	ns
Data Delay Time	$t_{DD}$	—	400	ns
Read Data Hold Time	$t_{DHR}$	50	—	ns

( Referenced to  $V_{SS} = 0\text{ V}$ ,  $DV_{DD} = AV_{DD} = 2.7\text{ to }3.3\text{ V}$ ,  
 $V_{CC} = AV_{DD}$ ,  $T_a = -20\text{ to }60^\circ\text{C}$  unless otherwise noted )

Characteristics	Symbol	Min	Max	Unit
Enable Cycle Time	$t_{\text{cycE}}$	500	—	ns
Enable Pulse Width	PWEL	300	—	ns
Enable Rise/Fall Time	$t_{\text{Er}}$ , $t_{\text{Ef}}$	—	15	ns
Address Setup Time	$t_{\text{AS}}$	20	—	ns
Address Hold Time	$t_{\text{AH}}$	20	—	ns
Data Setup Time	$t_{\text{DS}}$	60	—	ns
Write Data Hold Time	$t_{\text{DHW}}$	50	—	ns
Data Delay Time	$t_{\text{DD}}$	—	200	ns
Read Data Hold Time	$t_{\text{DHR}}$	20	—	ns

**AC Characteristics (2)**

- 68-series parallel interface read / write characteristics

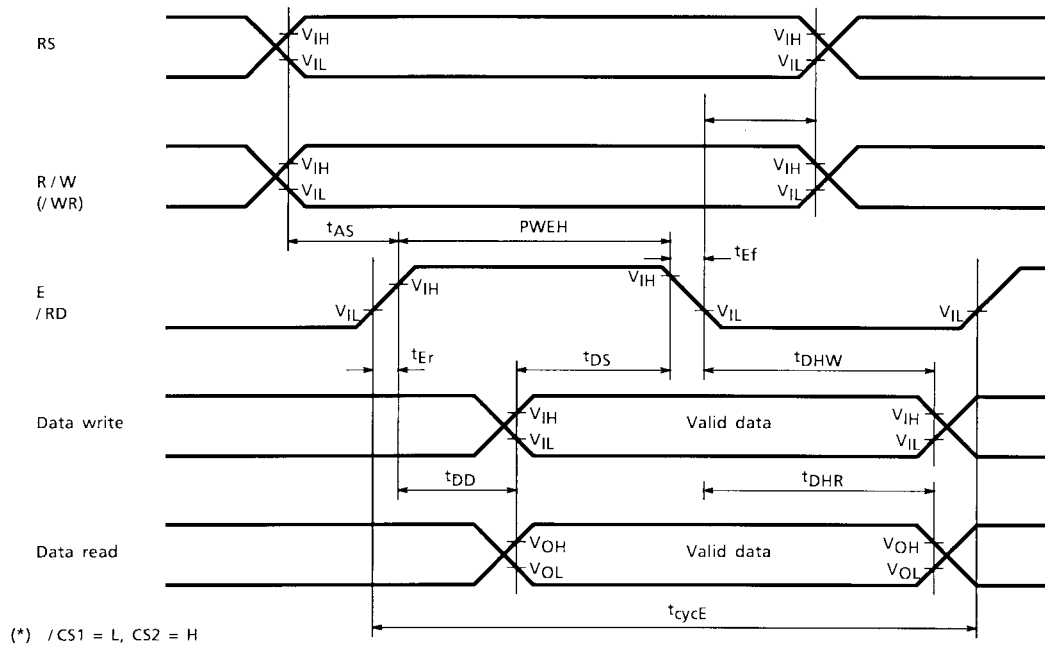

**Test Condition**

( Referenced to  $V_{SS} = 0\text{ V}$ ,  $DV_{DD} = AV_{DD} = 2.4\text{ to }2.7\text{ V}$ ,  
 $V_{CC} = AV_{DD}$ ,  $T_a = -20\text{ to }60^\circ\text{C}$  unless otherwise noted )

Characteristics	Symbol	Min	Max	Unit
Enable Cycle Time	$t_{cycE}$	1000	—	ns
Enable Pulse Width	$PWEL$	500	—	ns
Enable Rise / Fall Time	$t_{Er}$ , $t_{Ef}$	—	20	ns
Address Setup Time	$t_{AS}$	25	—	ns
Address Hold Time	$t_{AH}$	25	—	ns
Data Setup Time	$t_{DS}$	130	—	ns
Write Data Hold Time	$t_{DHW}$	70	—	ns
Data Delay Time	$t_{DD}$	—	400	ns
Read Data Hold Time	$t_{DHR}$	50	—	ns

( Referenced to  $V_{SS} = 0\text{ V}$ ,  $V_{DD} = 2.7\text{ to }3.3\text{ V}$ ,  $V_{CC} = AV_{DD}$ , )  
Ta = -20 to 60°C unless otherwise noted

Characteristics	Symbol	Min	Max	Unit
Enable Cycle Time	$t_{cycE}$	500	—	ns
Enable Pulse Width	PWEL	300	—	ns
Enable Rise/Fall Time	$t_{Er}$ , $t_{Ef}$	—	15	ns
Address Setup Time	$t_{AS}$	20	—	ns
Address Hold Time	$t_{AH}$	20	—	ns
Data Setup Time	$t_{DS}$	60	—	ns
Write Data Hold Time	$t_{DHW}$	50	—	ns
Data Delay Time	$t_{DD}$	—	200	ns
Read Data Hold Time	$t_{DHR}$	20	—	ns

**AC Characteristics (3)**

- Serial interface read / write characteristics

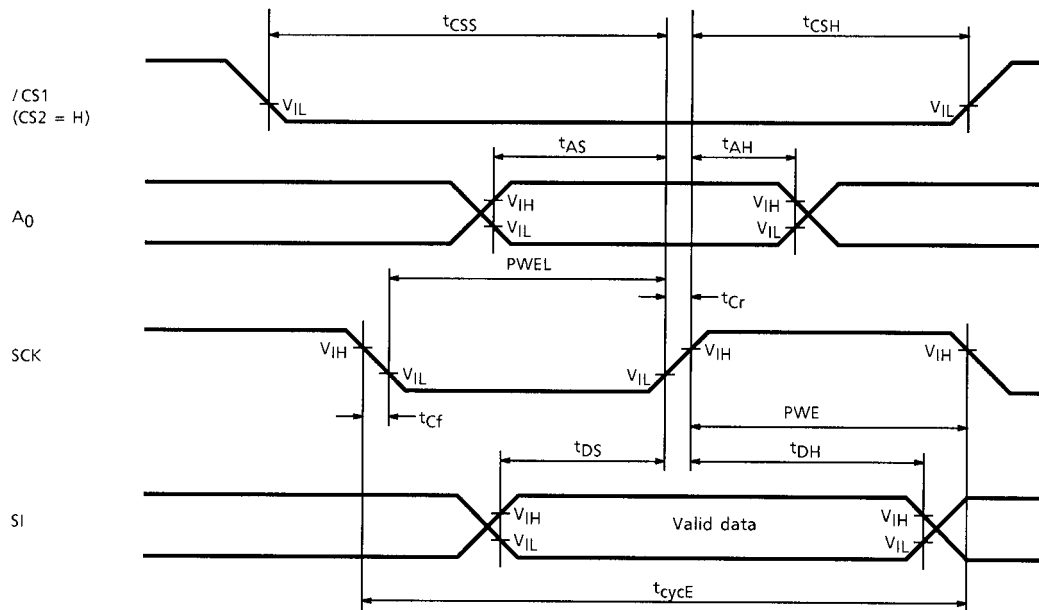

**Test Condition**

( Referenced to  $V_{SS} = 0\text{ V}$ ,  $DV_{DD} = AV_{DD} = 2.4\text{ to }2.7\text{ V}$ ,  
 $V_{CC} = AV_{DD}$ ,  $T_a = -20\text{ to }60^\circ\text{C}$  unless otherwise noted )

Characteristics	Symbol	Min	Max	Unit
Clock Cycle Time	$t_{cycC}$	1000	—	ns
Clock Pulse Width	PWCL, PWCH	500	—	ns
Clock Rise/Fall Time	$t_{Cr}$ , $t_{Cf}$	—	20	ns
CS Setup Time	$t_{CSS}$	300	—	ns
CS Hold Time	$t_{CSH}$	300	—	ns
Address Setup Time	$t_{AS}$	300	—	ns
Address Hold Time	$t_{AH}$	300	—	ns
Data Setup Time	$t_{DS}$	—	250	ns
Data Hold Time	$t_{DH}$	250	—	ns

( Referenced to  $V_{SS} = 0\text{ V}$ ,  $DV_{DD} = AV_{DD} = 2.7\text{ to }3.3\text{ V}$ ,  
 $V_{CC} = AV_{DD}$ ,  $T_a = -20\text{ to }60^\circ\text{C}$  unless otherwise noted )

Characteristics	Symbol	Min	Max	Unit
Clock Cycle Time	$t_{cycC}$	400	—	ns
Clock Pulse Width	PWCL, PWCH	150	—	ns
Clock Rise/Fall Time	$t_{Cr}$ , $t_{Cf}$	—	15	ns
CS Setup Time	$t_{CSS}$	250	—	ns
CS Hold Time	$t_{CSH}$	250	—	ns
Address Setup Time	$t_{AS}$	250	—	ns
Address Hold Time	$t_{AH}$	250	—	ns
Data Setup Time	$t_{DS}$	—	150	ns
Data Hold Time	$t_{DH}$	150	—	ns

## Example of Application Circuit

T6K11

- Internal CR oscillator used
- ×5 step-up circuit used
- 8-bit parallel MPU interface used

