

T54LS247/248

T74LS247/248

# LOW POWER SCHOTTKY INTEGRATED CIRCUITS

67C 16345 D T-51-17

PRELIMINARY DATA

## BCD-TO-SEVEN SEGMENT DECODER/DRIVES

### DESCRIPTION

The T54LS/T74LS247/248 are BCD-to-seven segment Decoder/Drivers. They compose the and with the tails. The LS247 has active low outputs for direct drive of indicators, while the LS248 has active - high outputs for driving lamp buffers. Both types feature a lamp test input and full ripple-blanking input/output controls. An automatic leading and/or trailing edge zero-blanking control (RBI and RBO) is incorporated. An over-riding blanking input (BI) may be used to control the lamp intensity. Display pattern for BCD input counts above 9 are unique symbols to authenticate input conditions.

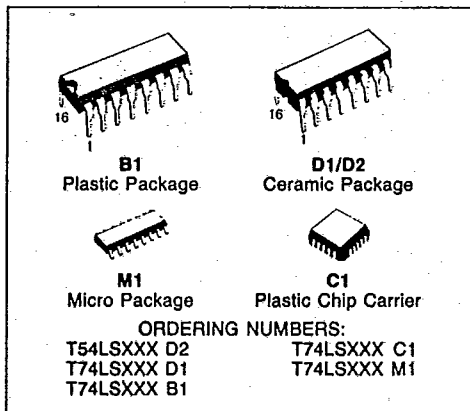

### LS247

- OPEN-COLLECTR OUTPUTS DRIVE INDICATORS DIRECTLY
- LAMP-TEST PROVISION
- LEADING/TRAILING ZERO SUPPRESSION

### LS248

- INTERNAL PULL-UPS ELIMINATE NEED FOR EXTERNAL RESISTORS
- LAMP-TEST PROVISION
- LEADING/TRAILING ZERO SUPPRESSION

### PIN NAMES

A,B,C,D	Inputs
a,b,c,d,e,f,g	Outputs
LT	Lamp Test
RBO	Rubout Outputs
RBI	Rubout Inputs
BI	Blanking Inputs

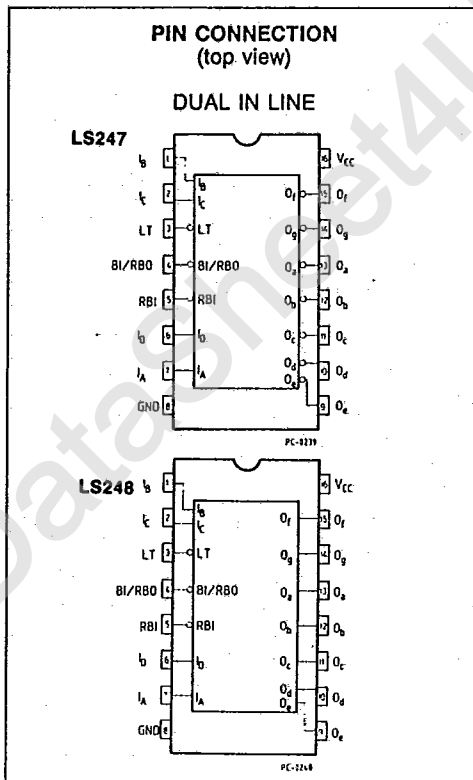

www.DataSheet4U.com

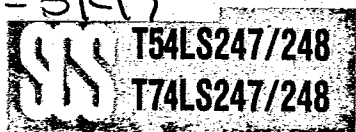

**CHIP CARRIER**

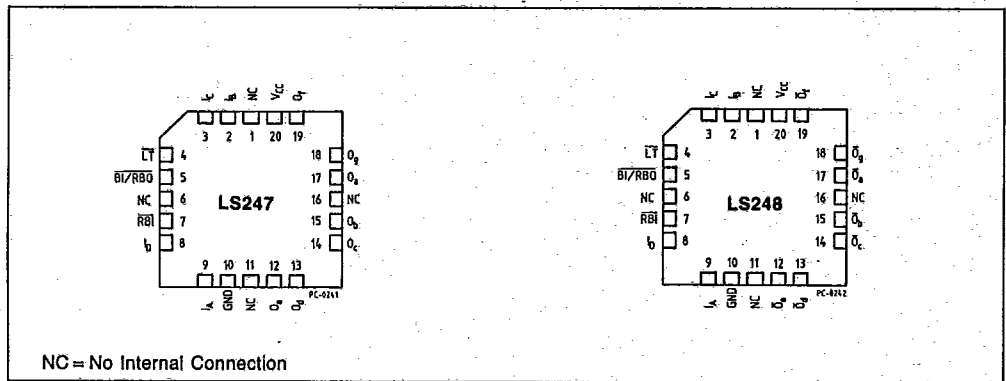

**ALL CIRCUIT TYPES FEATURE LAMP INTENSITY MODULATION CAPABILITY**

TYPE	DRIVER OUTPUTS				TYPICAL POWER DISSIPATION
	ACTIVE LEVEL	OUTPUT CONFIGURATION	SINK CURRENT	MAX VOLTAGE	
T54LS247 T54LS248	low high	open-collector 2-kΩ pull-up	12 mA 2.0 mA	15 V 5.5 V	35 mW 125 mW
T74LS247 T74LS248	low high	open-collector 2-kΩ pull-up	24 mA 6.0 mA	15 V 5.5 V	35 mW 125 mW

**ABSOLUTE MAXIMUM RATINGS**

Symbol	Parameter	Value	Unit
V <sub>CC</sub>	Supply Voltage	-0.5 to 7	V
V <sub>I</sub>	Input Voltage, Applied to Input	-0.5 to 15	V
V <sub>O</sub>	Output Voltage, Applied to Output	0 to 10	V
I <sub>I</sub>	Input Current, Into Inputs	-30 to 5	mA
I <sub>O</sub>	Output Current, Into Outputs	50	mA

Stresses in excess of those listed under "Absolute Maximum Ratings" may cause permanent damage to the device. This is a stress rating only and functional operation of the device at these or any other conditions in excess of those indicated in the operational sections of this specification is not implied. Exposure to absolute maximum rating conditions for extended periods may affect device reliability.

**GUARANTEED OPERATING RANGES**

Part Numbers	Supply Voltage			Temperature
	Min	Typ	Max	
T54LS247/248D2	4.5 V	5.0 V	5.5 V	-55°C to +125°C
T74LS247/248XX	4.75 V	5.0 V	5.25 V	0°C to +70°C

XX = package type.



LOGIC DIAGRAMS

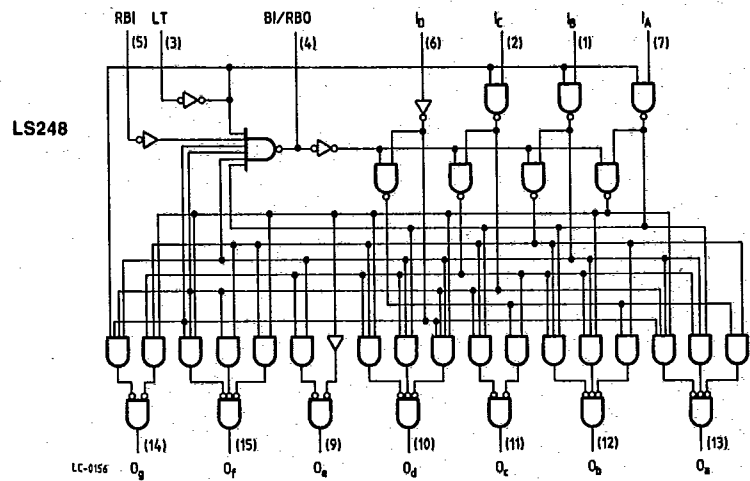
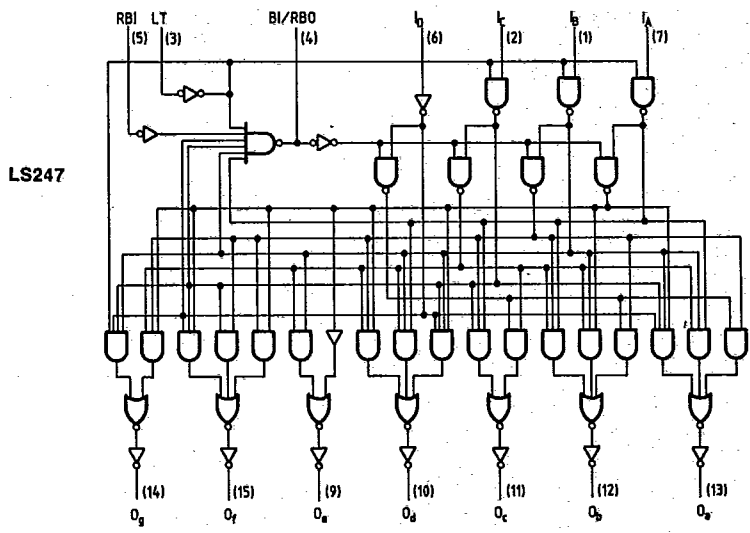

VCC = Pin 16  
 GND = Pin 8  
 () = Pin numbers

0	1	5	3	4	2	6	7	8	9	10	11	15	13	14	12	F
---	---	---	---	---	---	---	---	---	---	----	----	----	----	----	----	---

NUMERICAL DESIGNATIONS AND RESULTANT DISPLAY

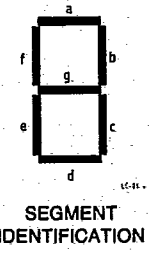

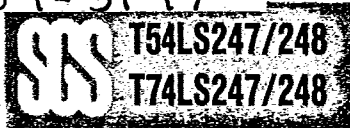

**LS247 TRUTH TABLE**

DECIMAL OR FUNCTION	INPUTS					BI/RBO*	OUTPUTS							NOTE
	LT	RBI	D	C	B		A	a	b	c	d	e	f	
0	H	H	L	L	L	L	H	ON	ON	ON	ON	ON	ON	OFF
1	H	X	L	L	L	H	H	OFF	ON	ON	OFF	OFF	OFF	OFF
2	H	X	L	L	H	L	H	ON	ON	OFF	ON	ON	OFF	ON
3	H	X	L	L	H	H	H	ON	ON	ON	ON	OFF	OFF	ON
4	H	X	L	H	L	L	H	OFF	ON	ON	OFF	OFF	ON	ON
5	H	X	L	H	L	H	H	ON	OFF	ON	ON	OFF	ON	ON
6	H	X	L	H	H	L	H	ON	OFF	ON	ON	ON	ON	ON
7	H	X	L	H	H	H	H	ON	ON	ON	OFF	OFF	OFF	OFF
8	H	X	H	L	L	L	H	ON	ON	ON	ON	ON	ON	ON
9	H	X	H	L	L	H	H	ON	ON	ON	ON	OFF	ON	ON
10	H	X	H	L	H	L	H	OFF	OFF	OFF	ON	ON	OFF	ON
11	H	X	H	L	H	H	H	OFF	OFF	ON	ON	OFF	OFF	ON
12	H	X	H	H	L	L	H	OFF	ON	OFF	OFF	OFF	ON	ON
13	H	X	H	H	L	H	H	ON	OFF	OFF	ON	OFF	ON	ON
14	H	X	H	H	H	L	H	OFF	OFF	OFF	ON	ON	ON	ON
15	H	X	H	H	H	H	H	OFF	OFF	OFF	OFF	OFF	OFF	OFF
BI	X	X	X	X	X	X	L	OFF	OFF	OFF	OFF	OFF	OFF	OFF
RBI	H	L	L	L	L	L	L	OFF	OFF	OFF	OFF	OFF	OFF	OFF
LT	L	X	X	X	X	X	H	ON	ON	ON	ON	ON	ON	ON

**LS248 TRUTH TABLE**

DECIMAL OR FUNCTION	INPUTS					BI/RBO*	OUTPUTS							NOTE
	LT	RBI	D	C	B		A	a	b	c	d	e	f	
0	H	H	L	L	L	L	H	H	H	H	H	H	H	L
1	H	X	L	L	L	H	H	L	H	H	L	L	L	L
2	H	X	L	L	H	L	H	H	H	L	H	L	H	H
3	H	X	L	L	H	H	H	H	H	H	L	L	L	H
4	H	X	L	H	L	L	H	L	H	H	L	L	H	H
5	H	X	L	H	L	H	H	H	L	H	H	L	H	H
6	H	X	L	H	H	L	H	H	L	H	H	H	H	H
7	H	X	L	H	H	H	H	H	H	H	L	L	L	L
8	H	X	H	L	L	L	H	H	H	H	H	H	H	H
9	H	X	H	L	L	H	H	H	H	H	H	L	H	H
10	H	X	H	L	H	L	H	L	L	L	H	H	L	H
11	H	X	H	L	H	H	H	L	L	H	H	L	L	H
12	H	X	H	H	L	L	H	L	H	L	L	L	H	H
13	H	X	H	H	L	H	H	H	L	L	L	H	H	H
14	H	X	H	H	H	L	H	L	L	L	H	H	H	H
15	H	X	H	H	H	H	H	L	L	L	L	L	L	L
BI	X	X	X	X	X	X	L	L	L	L	L	L	L	L
RBI	H	L	L	L	L	L	L	L	L	L	L	L	L	L
LT	L	X	X	X	X	X	H	H	H	H	H	H	H	H

H=HIGH Level, L=LOW Voltage Level, X=Don't Care  
 NOTES: 1. The Blanking input (BI) must be open or held at a high logic level when output functions 0 through 15 are desired. The ripple-blanking input (RBI) must be open or high if blanking of a decimal zero is not desired.  
 2. When a low logic level is applied directly to the blanking input (BI), all segment outputs are off regardless of the level of any other input.  
 3. When ripple-blanking input (RBI) and inputs A, B, C, and D are at a low level with the lamp test input high, all segment outputs go off and the ripple-blanking output (RBO) goes to a low level (response condition).  
 4. When the blanking input/ripple blanking output (BI/RBO) is open or held high and a low is applied to the lamp-test input, all segment outputs are on.  
 \* BI/RBO is wire-AND logic serving as blanking input (BI) and/or ripple-blanking output (RBO).

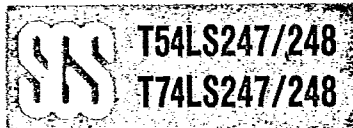

## DC CHARACTERISTICS OVER OPERATING TEMPERATURE RANGE (T54LS/T74LS247)

Symbol	Parameter		Limits			Test Conditions (Note 1)	Units
			Min.	Typ.	Max.		
$V_{IH}$	Input HIGH Voltage		2.0			Guaranteed Input HIGH Voltage for all Inputs	V
$V_{IL}$	Input LOW Voltage	54			0.7	Guaranteed Input LOW Voltage for all Inputs	V
		74			0.8		
$V_{CD}$	Input Clamp Diode Voltage			-0.65	-1.5	$V_{CC} = \text{MIN}, I_{IN} = -18\text{mA}$	V
$V_{OH}$	Output HIGH Voltage BI/RBO	54	2.4	4.2		$V_{CC} = \text{MIN}, I_{OH} = -50\mu\text{A}, V_{IN} = V_{IH}$ or $V_{IL}$ per Truth Table	V
		74	2.4	4.2			
$V_{OL}$	Output LOW Voltage BI/RBO	54,74		0.25	0.4	$I_{OL} = 4.0\text{mA}$ $V_{CC} = \text{MIN}, V_{IN} = V_{IL}$ or $V_{IH}$ per Truth Table	V
		74		0.35	0.5		
$I_{O(off)}$	Off-State Output Current a-g	54,74			250	$V_{CC} = \text{MAX}, V_{IH} = 2.0\text{V}$ $V_{O(off)} = 15\text{V}, V_{IL} = \text{MAX}$	$\mu\text{A}$
$V_{O(on)}$	On-State Output Voltage a-g	54,74		0.25	0.4	$I_{O(on)} = 12\text{mA}$ $V_{CC} = \text{MIN}, V_{IH} = 2.0\text{V}$ $I_{OL} = 24\text{mA}$ $V_{IL}$ per Truth Table	V
		74		0.35	0.5		
$I_{IH}$	Input HIGH Current				20	$V_{CC} = \text{MAX}, V_{IN} = 2.7\text{V}$ $V_{CC} = \text{MAX}, V_{IN} = 7.0\text{V}$	$\mu\text{A}$ mA
					0.1		
$I_{IL}$	Input LOW Current Any Input, except BI/RBO BI/RBO				-0.4	$V_{CC} = \text{MAX}, V_{IN} = 0.4\text{V}$	mA
					-1.2		
$I_{OS}$	Output Short Circuit Current BI/RBO (Note 2)		-0.3		-2.0	$V_{CC} = \text{MAX}$	mA
$I_{CC}$	Power Supply Current			7.0	13	$V_{CC} = \text{MAX}$	mA

AC CHARACTERISTICS:  $T_A = 25^\circ\text{C}$  (T54LS/T74LS247)

Symbol	Parameter		Limits			Test Conditions	Units
			Min.	Typ.	Max.		
$t_{PLH}$	Turn-Off Time from A Input				100	$C_L = 15\text{pF}, R_L = 665\Omega$	ns
$t_{PHL}$	Turn-On Time from A Input				100		
$t_{PLH}$	Turn-Off Time from RBI Input				100		ns
$t_{PHL}$	Turn-On Time from RBI Input				100		

## Notes:

- 1) For conditions shown as MIN or MAX, use the appropriate value specified under guaranteed operating ranges.
- 2) Not more than one output should be shorted at a time.
- 3) Typical values are at  $V_{CC} = 5.0\text{V}, T_A = 25^\circ\text{C}$

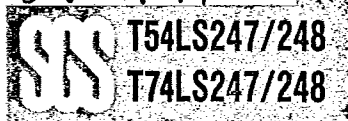

## DC CHARACTERISTICS OVER OPERATING TEMPERATURE RANGE (T54LS/T74LS248)

Symbol	Parameter	Limits			Test Conditions (Note 1)	Units
		Min.	Typ.	Max.		
$V_{IH}$	Input HIGH Voltage	2.0			Guaranteed input HIGH Voltage for all Inputs	V
$V_{IL}$	Input LOW Voltage	54		0.7	Guaranteed input LOW Voltage for all Inputs	V
		74		0.8		
$V_{CD}$	Input Clamp Diode Voltage		-0.65	-1.5	$V_{CC} = \text{MIN}, I_{IN} = -18\text{mA}$	V
$V_{OH}$	Output HIGH Voltage BI/RBO	54	2.4	4.2	$V_{CC} = \text{MIN}, I_{OH} = \text{MAX}^*, V_{IN} = V_{IH}$ or $V_{IL}$ per Truth Table	V
		74	2.4	4.2		
$I_O$	Output Current a-g	54,74	-1.3	-20	$V_{CC} = \text{MIN}, V_O = 0.85\text{V}$ Input Conditions as for $V_{OH}$	
$V_{OL}$	Output LOW Voltage a-g	54,74		0.25	$I_{OL} = 2.0\text{mA}$	V
		74		0.35	$I_{OL} = 3.2\text{mA}$	
	BI/RBO	54,74		0.25	$I_{OL} = 1.6\text{mA}$	$V_{IL} = \text{per Truth Table}$
		74		0.35	$I_{OL} = 3.2\text{mA}$	
$I_{IH}$	Input HIGH Current			20 0.1	$V_{CC} = \text{MAX}, V_{IN} = 2.7\text{V}$ $V_{CC} = \text{MAX}, V_{IN} = 7.0\text{V}$	$\mu\text{A}$
$I_{IL}$	Input LOW Current Any Input, except BI/RBO BI/RBO			-0.4 -1.2	$V_{CC} = \text{MAX}, V_{IN} = 0.4\text{V}$	mA
$I_{OS}$	Output Short Circuit Current BI/RBO (Note 2)	-0.3		-2.0	$V_{CC} = \text{MAX}$	mA
$I_{CC}$	Power Supply Current		25	38	$V_{CC} = \text{MAX}$	mA

\*  $I_{OH} = -50\mu\text{A}$  for BI/RBO,  $I_{OH} = -100\mu\text{A}$  for a-g

AC CHARACTERISTICS:  $T_A = 25^\circ\text{C}$ ,  $V_{CC} = 5.0\text{V}$  (T54LS/T74LS248)

Symbol	Parameter	Limit Max	Test Condition	Units
$t_{PHL}$	Propagation Delay Time, High-to-Low-Level Output from A Input	100	$C_L = 15\text{pF}$ $R_L = 4.0\text{k}\Omega$	
$t_{PLH}$	Propagation Delay Time, Low-to-High-Level Output from A Input	100		
$t_{PHL}$	Propagation Delay Time, High-to-Low-Level Output from RBI Input	100	$C_L = 15\text{pF}$ $R_L = 6.0\text{k}\Omega$	
$t_{PLH}$	Propagation Delay Time, Low-to-High-Level Output from RBI Input	100		

## Notes:

- 1) For conditions shown as MIN or MAX, use the appropriate value specified under guaranteed operating ranges.
- 2) Not more than one output should be shorted at a time.
- 3) Typical values are at  $V_{CC} = 5.0\text{V}$ ,  $T_A = 25^\circ\text{C}$

### 14-LEAD PLASTIC DIP

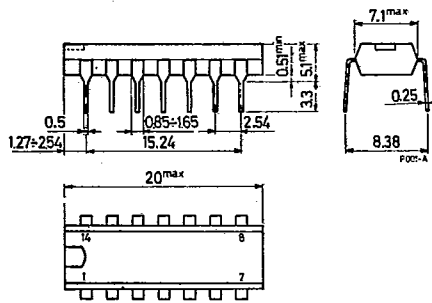
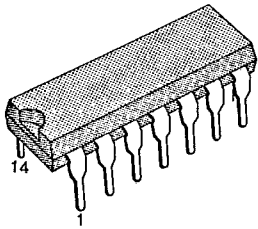

### 14-LEAD CERAMIC DIP

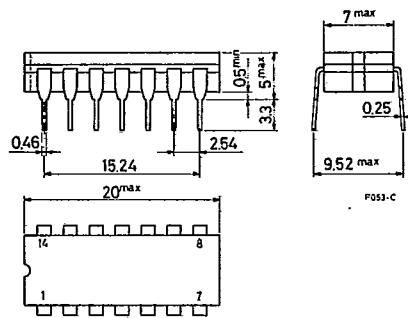
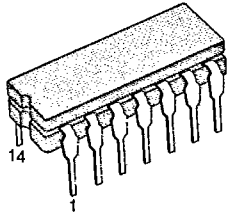

### 16-LEAD PLASTIC DIP

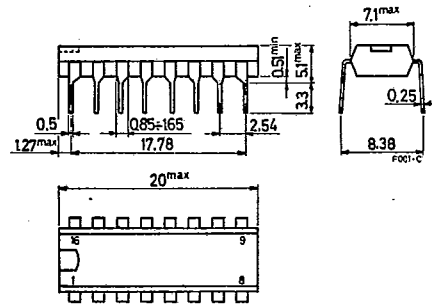
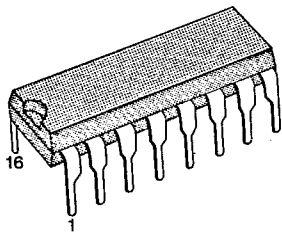

# Packages

67C 16545

D

T-90-20

## 16-LEAD CERAMIC DIP

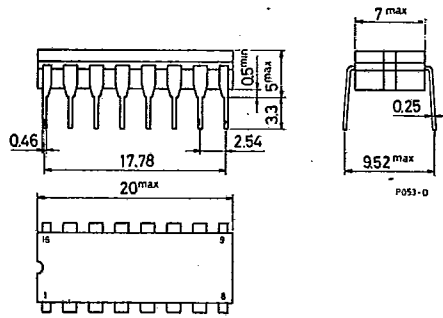
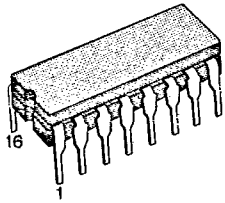

## 20-LEAD PLASTIC DIP

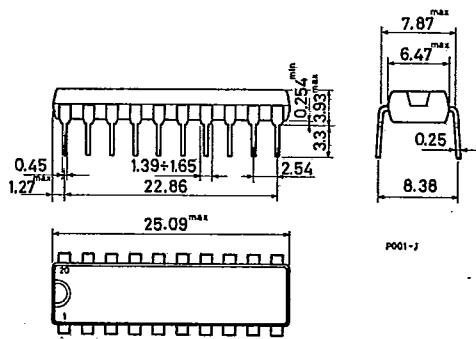
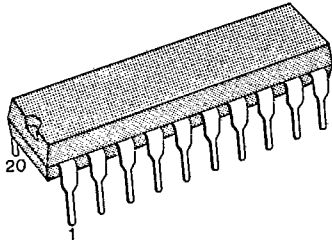

## 20-LEAD CERAMIC DIP

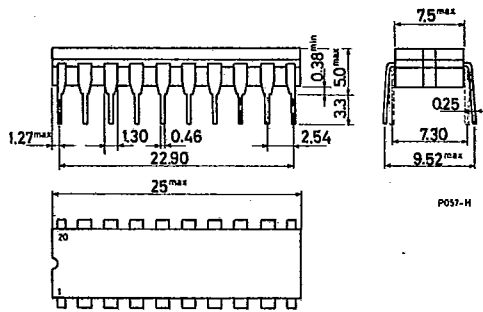
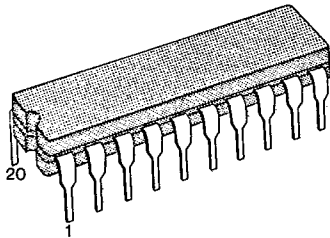



24-LEAD PLASTIC DIP

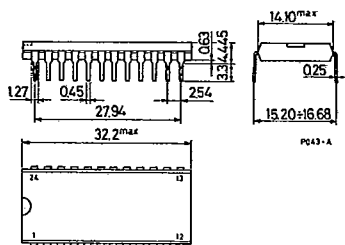
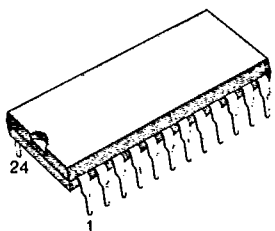

24-LEAD CERAMIC DIP

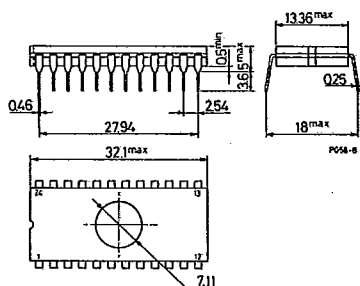
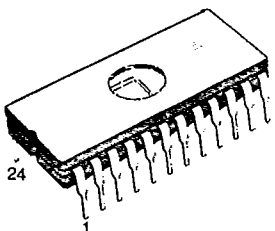

CHIP CARRIER 20 LEAD PLASTIC

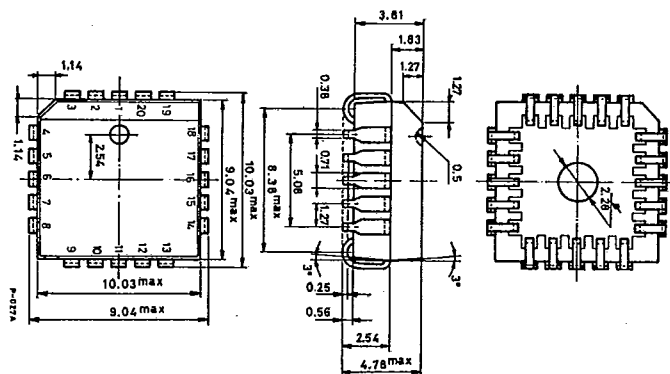
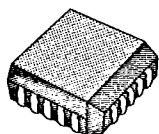

# Packages

67C 16547

D

T-90-20

## 14-LEAD PLASTIC DIP MICROPACKAGE

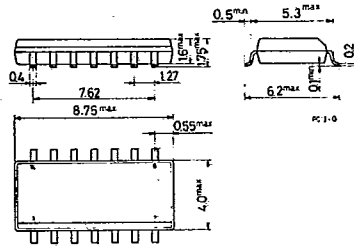
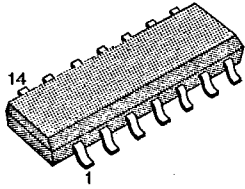

## 16-LEAD PLASTIC DIP MICROPACKAGE

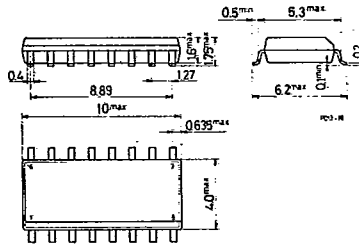
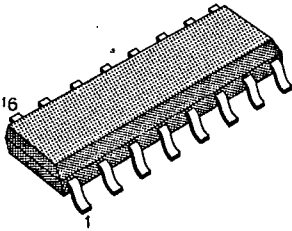

NOTE: FOR 20-LEAD PLASTIC DIP MICROPACKAGE CONTACT SGS

# Surface Mounted

67C 16548

D

T-90-20

One possible solution to the important problem of PWB minimization, is that of using surface mounted components. Integrated circuits in SO (Small Outline) packages are made up of standard chips mounted in very small plastic packages. The advantages given by using these devices are:

### PWB Reduction

This is by far the most important advantage since the reduction of PWB size varies from 40 to 60% in comparison with standard board types. (See page 584 for package dimensions.)

### Assembly Cost Reduction

SO Devices require no preliminary operation prior to mounting and can therefore be easily utilized in fully automatic equipment.

### Increasing Reliability

The following characteristics lead to a higher level of reliability with respect to their standard packaged counter parts:

- The mounting system is fully automatic
- PWB number and the interconnections between them are reduced when the same number of devices are used.
- The high density of components on the board makes it thermally much more stable.

### Noise Reduction and Improved Frequency Response

The reduction of the length of the connecting wires between the leads and the silicon guarantees a more homogeneous propagation delay between the external pins, with respect to the standard type.

### Assembly Without Board Holes

The devices are placed on the board and soldered. This technology permits a higher level of tolerance in the positioning (automatic) of the device. For the standard DIP types this must be done with great accuracy due to the insertion of the leads into their holes.

