

QUAD 2-INPUT NAND BUFFER

DESCRIPTION

The T74LS37 is a high speed QUAD 2-INPUT NAND BUFFER fabricated in LOW POWER SCHOTTKY technology.

SCHEMATIC

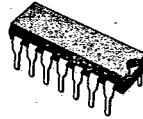
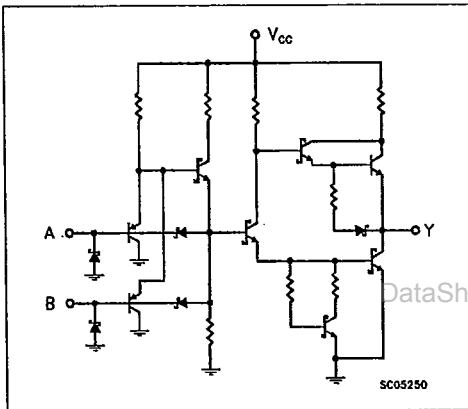

B1
(Plastic Package)

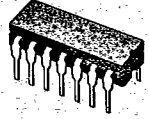

D1
(Ceramic Package)



M1
(Micro Package)



C1
(Plastic Chip Carrier)

ORDER CODES :

T74LS37 D1
T74LS37 B1

T74LS37 C1
T74LS37 M1

PIN CONNECTION (top view)

DUAL IN LINE

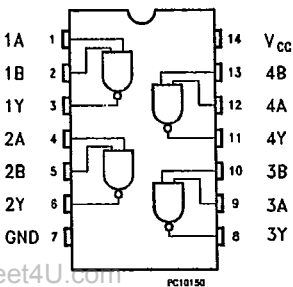

CHIP CARRIER

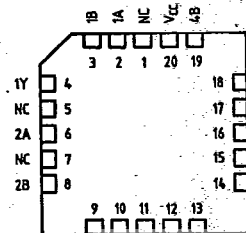

NC = No Internal Connection



| A | B | Y |
|---|---|---|
| L | X | H |
| X | L | H |
| H | H | L |

L = LOW Voltage Level
H = HIGH Voltage Level
X = Don't Care

ABSOLUTE MAXIMUM RATINGS

| Symbol | Parameter | Value | Unit |
|-----------------|-----------------------------------|--------------|------|
| V _{CC} | Supply Voltage | - 0.5 to 7 | V |
| V _I | Input Voltage, Applied to Input | - 0.5 to 15 | V |
| V _O | Output Voltage, Applied to Output | - 0.5 to 5.5 | V |
| I _I | Input Current, Into Inputs | - 30 to 5 | mA |
| I _O | Output Current, Into Outputs | 60 | mA |

Stresses in excess of those listed under "Absolute Maximum Ratings" may cause permanent damage to the device. This is a stress rating only and functional operation of the device at these or any other conditions in excess of those indicated in the operational sections of this specification is not implied. Exposure to absolute maximum rating conditions for extended periods may affect device reliability.

GUARANTEED OPERATING RANGE

| Part Numbers | Supply Voltage | | | Temperature |
|--------------|----------------|-------|--------|-----------------|
| | Min. | Typ. | Max. | |
| T74LS37XX | 4.75 V | 5.0 V | 5.25 V | 0 °C to + 70 °C |

XX = package type.

DC CHARACTERISTICS OVER OPERATING TEMPERATURE RANGE

| Symbol | Parameter | Limits | | | Test Condition (note 1) | Unit | |
|------------------|--|--------|----------|-----------|--|--|---|
| | | Min. | Typ. (*) | Max. | | | |
| V _{IH} | Input HIGH Voltage | 2.0 | | | Guaranteed Input HIGH Voltage | V | |
| V _{IL} | Input LOW Voltage | | | 0.8 | Guaranteed Input LOW Voltage | V | |
| V _{CO} | Input Clamp Diode Voltage | | - 0.65 | - 1.5 | V _{CC} = MIN, I _{IN} = - 18 mA | V | |
| V _{OH} | Output HIGH Voltage | 2.7 | 3.4 | | V _{CC} = MIN, I _{OH} = - 1.2 mA, V _{IN} = V _{IL} | V | |
| V _{OL} | Output LOW Voltage | | 0.25 | 0.4 | I _{OL} = 12 mA | V _{CC} = MIN V _{IN} = 2.0 V | V |
| | | | 0.35 | 0.5 | I _{OL} = 24 mA | | V |
| I _{IH} | Input HIGH Current | | 1.0 | 20 0.1 | V _{CC} = MAX, V _{IN} = 2.7 V V _{CC} = MAX, V _{IN} = 7.0 V | µA mA | |
| I _{IL} | Input LOW Current | | | - 0.4 | V _{CC} = MAX, V _{IN} = 0.4 V | mA | |
| I _{OS} | Output Short Circuit Current (note 2) | - 30 | | - 130 | V _{CC} = MAX, V _{OUT} = 0 V | mA | |
| I _{CCH} | Supply Current HIGH | | 0.9 | 2.0 | V _{CC} = MAX, V _{IN} = 0 V | mA | |
| I _{CCL} | Supply Current LOW | | 6.0 | 12 | V _{CO} = MAX, Inputs Open | mA | |

Notes : 1. For conditions shown as MIN or MAX, use the appropriate value specified under guaranteed operating ranges.
2. Not more than one output should be shorted at a time.
(*) Typical values are at V_{CC} = 5.0 V, T_A = 25 °C.

AC CHARACTERISTICS: $T_A = 25^\circ\text{C}$ (for AC test circuits and waveforms see databook introduction)

| Symbol | Parameter | Limits | | | Test Conditions | Unit |
|-----------|---------------------------------|--------|------|------|--|------|
| | | Min. | Typ. | Max. | | |
| t_{PLH} | Turn Off Delay, Input to Output | | 12 | 24 | $V_{CC} = 5.0\text{ V}$ $C_L = 45\text{ pF}, R_L = 667\ \Omega$ | ns |
| t_{PHL} | Turn On Delay, Input to Output | | 12 | 24 | | ns |