



DUAL 4-INPUT NAND BUFFER

DESCRIPTION

The T54LS40/T74LS40 is a high speed DUAL 4-INPUT NAND BUFFER fabricated in LOW POWER SCHOTTKY technology.

B1
Plastic Package

D1/D2
Ceramic Package

M1
Micro Package

C1
Plastic Chip Carrier

ORDERING NUMBERS:
 T54LS40 D2 T74LS40 C1
 T74LS40 D1 T74LS40 M1
 T74LS40 B1

PIN CONNECTION (top view)

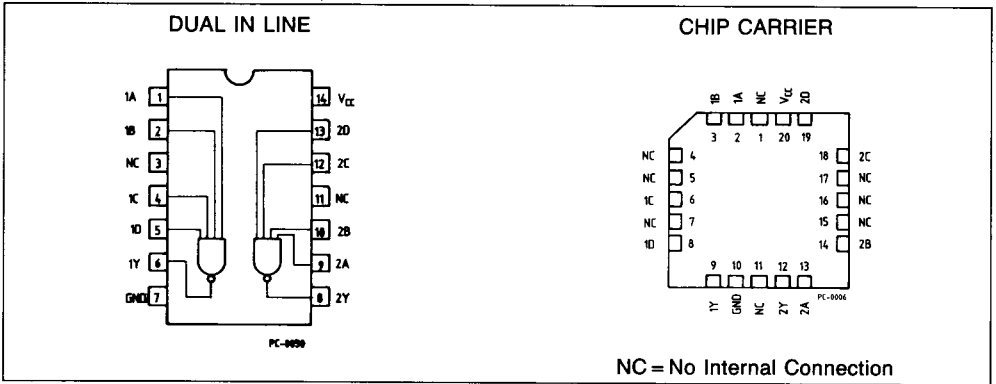

SCHEMATIC

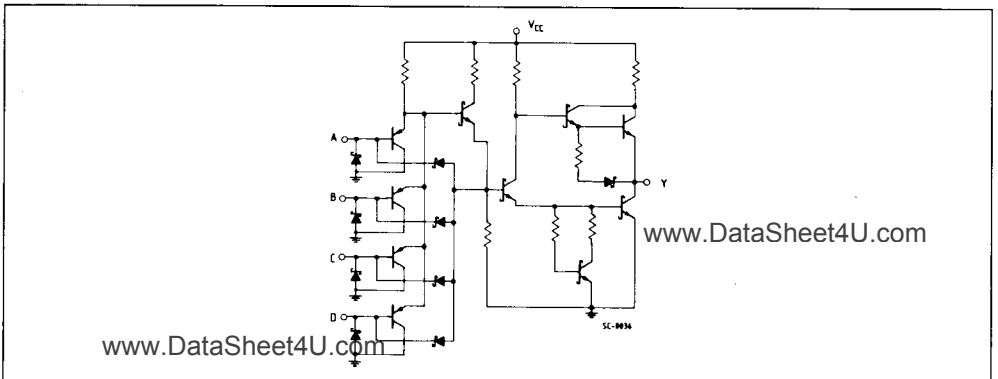



T54LS40
T74LS40

LOGIC DIAGRAM AND TRUTH TABLE



A	B	C	D	Y
L	X	X	X	H
X	L	X	X	H
X	X	L	X	H
X	X	X	L	H
H	H	H	H	L

L = LOW Voltage Level
H = HIGH Voltage Level
X = Don't Care

ABSOLUTE MAXIMUM RATINGS

Symbol	Parameter	Value	Unit
V_{CC}	Supply Voltage	-0.5 to 7	V
V_I	Input Voltage, Applied to Input	-0.5 to 15	V
V_O	Output Voltage, Applied to Output	-0.5 to 10	V
I_I	Input Current, Into Inputs	-30 to 5	mA
I_O	Output Current, Into Outputs	60	mA

Stresses in excess of those listed under "Absolute Maximum Ratings" may cause permanent damage to the device. This is a stress rating only and functional operation of the device at these or any other conditions in excess of those indicated in the operational sections of this specification is not implied. Exposure to absolute maximum rating conditions for extended periods may affect device reliability.

GUARANTEED OPERATING RANGES

Part Numbers	Supply Voltage			Temperature
	Min	Typ	Max	
T54LS40D2	4.5 V	5.0 V	5.5 V	-55°C to +125°C
T74LS40XX	4.75 V	5.0 V	5.25 V	0°C to +70°C

XX = package type.

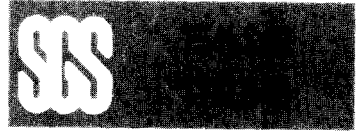

DC CHARACTERISTICS OVER OPERATING TEMPERATURE RANGE

Symbol	Parameter		Limits			Test Conditions (Note 1)	Units	
			Min.	Typ.	Max.			
V _{IH}	Input HIGH Voltage		2.0			Guaranteed input HIGH Voltage	V	
V _{IL}	Input LOW Voltage	54			0.7	Guaranteed input LOW Voltage	V	
		74			0.8			
V _{CD}	Input Clamp Diode Voltage			-0.65	-1.5	V _{CC} = MIN, I _{IN} = -18mA	V	
V _{OH}	Output HIGH Voltage	54	2.5	3.4		V _{CC} = MIN, I _{OH} = -1.2mA, V _{IN} = V _{IL}	V	
		74	2.7	3.4				
V _{OL}	Output LOW Voltage	54,74		0.25	0.4	I _{OL} = 12mA I _{OL} = 24mA	V _{CC} = MIN, V _{IN} = 2.0V	V
		74		0.35	0.5			
I _{IH}	Input HIGH Current			1.0	20 0.1	V _{CC} = MAX, V _{IN} = 2.7V V _{CC} = MAX, V _{IN} = 7.0V	μA mA	
I _{IL}	Input LOW Current				-0.4	V _{CC} = MAX, V _{IN} = 0.4V	mA	
I _{OS}	Output Short Circuit Current (Note 2)		-30		-130	V _{CC} = MAX, V _{OUT} = 0V	mA	
I _{CCH}	Supply Current HIGH			0.45	1.0	V _{CC} = MAX, V _{IN} = 0V	mA	
I _{CCL}	Supply Current LOW			3.0	6.0	V _{CC} = MAX, Inputs Open	mA	

AC CHARACTERISTICS: T_A = 25°C (See page 576 for AC test circuit and waveforms)

Symbol	Parameter		Limits			Test Conditions	Units
			Min.	Typ.	Max.		
t _{PLH}	Turn Off Delay, Input to Output			12	24	V _{CC} = 5.0V C _L = 45pF, R _L = 667Ω	ns
t _{PHL}	Turn On Delay, Input to Output			12	24		ns

Notes:

- 1) For conditions shown as MIN or MAX, use the appropriate value specified under guaranteed operating ranges.
- 2) Not more than one output should be shorted at a time.
- 3) Typical values are at V_{CC} = 5.0V, T_A = 25°C.