

ONE-OF-TEN DECODER

- MULTI-FUNCTION CAPABILITY
- MUTUALLY EXCLUSIVE OUTPUTS
- DEMULTIPLEXING CAPABILITY
- INPUT CLAMP DIODES LIMIT HIGH SPEED
- TERMINATION EFFECTS
- FULLY TTL AND CMOS COMPATIBLE

DESCRIPTION

The LSTTL/MSI T74LS42 is a Multipurpose Decoder designed to accept four BCD inputs and provide ten mutually exclusive outputs. The LS42 is fabricated with the Schottky barrier diodes for high speed and is completely compatible with all TTL families.

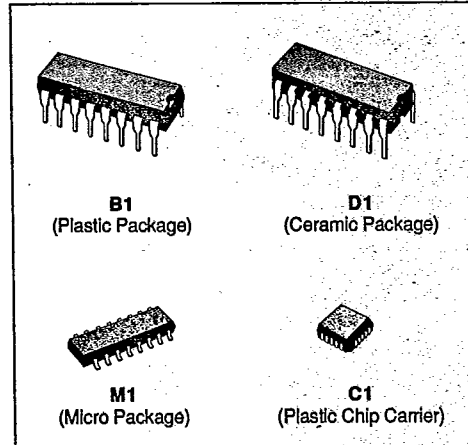

B1
(Plastic Package)

D1
(Ceramic Package)

M1
(Micro Package)

C1
(Plastic Chip Carrier)

ORDER CODES :
T74LS42 D1 T74LS42 C1
T74LS42 B1 T74LS42 M1

PIN NAMES

A ₀ to A ₃ 0 to 9	ADDRESS INPUTS OUTPUTS, ACTIVE LOW
--	---------------------------------------

PIN CONNECTION (top view)

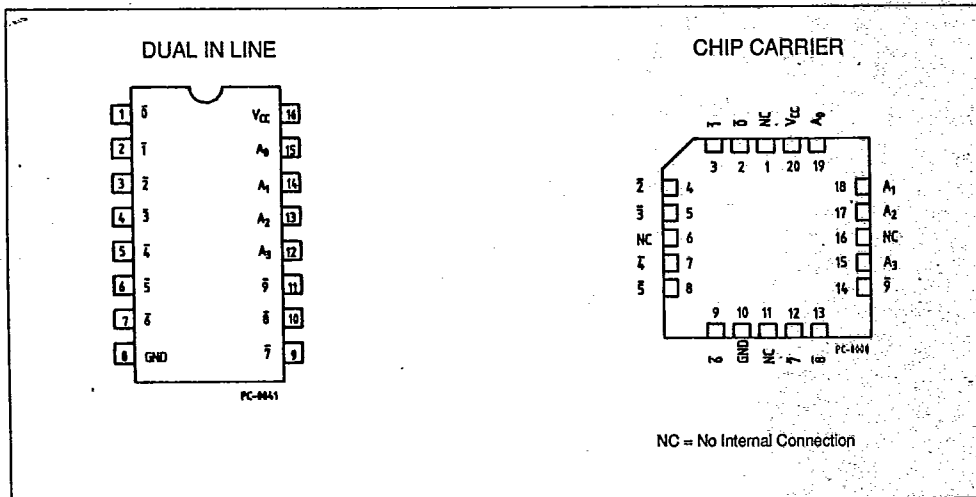

TRUTH TABLE

A ₀	A ₁	A ₂	A ₃	0	1	2	3	4	5	6	7	8	9
L	L	L	L	L	H	H	H	H	H	H	H	H	H
H	L	L	L	H	L	H	H	H	H	H	H	H	H
L	H	L	L	H	H	L	H	H	H	H	H	H	H
H	H	L	L	H	H	H	L	H	H	H	H	H	H
L	L	H	L	H	H	H	H	L	H	H	H	H	H
H	L	H	L	H	H	H	H	H	L	H	H	H	H
L	H	H	L	H	H	H	H	H	H	L	H	H	H
H	H	H	L	H	H	H	H	H	H	H	L	H	H
L	L	L	H	H	H	H	H	H	H	H	H	L	H
H	L	L	H	H	H	H	H	H	H	H	H	H	L
L	H	L	H	H	H	H	H	H	H	H	H	H	H
H	H	L	H	H	H	H	H	H	H	H	H	H	H
L	L	H	H	H	H	H	H	H	H	H	H	H	H
H	L	H	H	H	H	H	H	H	H	H	H	H	H
L	H	H	H	H	H	H	H	H	H	H	H	H	H
H	H	H	H	H	H	H	H	H	H	H	H	H	H

T-66-21-57

H = HIGH Voltage Level
L = LOW Voltage Level

LOGIC SYMBOL AND LOGIC DIAGRAM

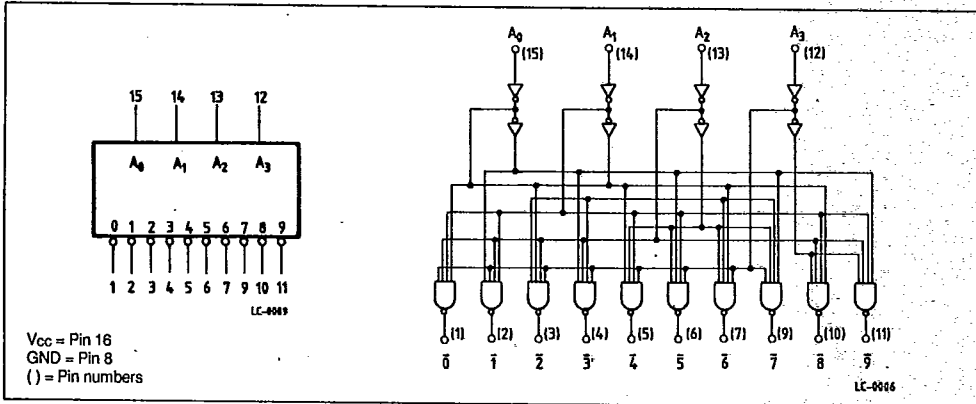

ABSOLUTE MAXIMUM RATINGS

Symbol	Parameter	Value	Unit
V _{CC}	Supply Voltage	- 0.5 to 7	V
V _I	Input Voltage, Applied to Input	- 0.5 to 15	V
V _O	Output Voltage, Applied to Output	- 0.5 to 10	V
I _I	Input Current, into Inputs	- 30 to 5	mA
I _O	Output Current, into Outputs	50	mA

Stresses in excess of those listed under "Absolute Maximum Ratings" may cause permanent damage to the device. This is a stress rating only and functional operation of the device at these or any other conditions in excess of those indicated in the operational sections of this specification is not implied. Exposure to absolute maximum rating conditions for extended periods may affect device reliability.

S G S-THOMSON 42E D ■ 7929237 0033280 6 ■ SGTH

GUARANTEED OPERATING RANGE

T-66-21-57

Part Numbers	Supply Voltage			Temperature
	Min.	Typ.	Max.	
T74LS42X	4.75 V	5.0 V	5.25 V	0 °C to + 70 °C

XX = package type.

FUNCTIONAL DESCRIPTION

The LS42 decoder accepts four active HIGH BCD inputs and provides ten mutually exclusive active LOW outputs, as shown by logic symbol or diagram. The active LOW outputs facilitate addressing other MSI units with active LOW input enables.

The logic design of the LS42 ensures that all outputs are HIGH when binary codes greater than nine are applied to the inputs.

The most significant input A_3 produces a useful inhibit function when the LS42 is used as a one-of-eight decoder. The A_3 input can also be used as the Data input in an 8-output demultiplexer application.

DC CHARACTERISTICS OVER OPERATING TEMPERATURE RANGE

Symbol	Parameter	Limits			Test Condition (note 1)	Unit	
		Min.	Typ. (*)	Max.			
V_{IH}	Input HIGH Voltage	2.0			Guaranteed Input HIGH Threshold Voltage for all inputs	V	
V_{IL}	Input LOW Voltage			0.8	Guaranteed Input LOW Threshold Voltage for all inputs	V	
V_{CD}	Input Clamp Diode Voltage		- 0.65	- 1.5	$V_{CC} = \text{MIN}, I_{IN} = -18 \text{ mA}$	V	
V_{OH}	Output HIGH Voltage	2.7	3.4		$V_{CC} = \text{MIN}, I_{OH} = -400 \mu\text{A}$ $V_{IN} = V_{IH} \text{ or } V_{IL} \text{ per Truth Table}$	V	
V_{OL}	Output LOW Voltage		0.25	0.4	$I_{OL} = 4.0 \text{ mA}$	$V_{CC} = \text{MIN}$ $V_{IN} = V_{IH} \text{ or } V_{IL}$ per Truth Table	V
			0.35	0.5	$I_{OL} = 8.0 \text{ mA}$		V
I_{IH}	Input HIGH Current			20 0.1	$V_{CC} = \text{MAX}, V_{IN} = 2.7 \text{ V}$ $V_{CC} = \text{MAX}, V_{IN} = 7.0 \text{ V}$	μA mA	
I_{IL}	Input LOW Current			- 0.4	$V_{CC} = \text{MAX}, V_{IN} = 0.4 \text{ V}$	mA	
I_{OS}	Output Short Circuit Current (note 2)	- 20		- 100	$V_{CC} = \text{MAX}, V_{OUT} = 0 \text{ V}$	mA	
I_{CC}	Power Supply Current		7.0	13	$V_{CC} = \text{MAX},$	mA	

Notes : 1. For conditions shown as MIN or MAX, use the appropriate value specified under guaranteed operating ranges.

2. Not more than one output should be shorted at a time.

(*) Typical values are at $V_{CC} = 5.0 \text{ V}, T_A = 25 \text{ }^\circ\text{C}$.

AC CHARACTERISTICS: $T_A = 25^\circ\text{C}$ (for AC test circuits and waveforms see databook introduction)

Symbol	Parameter	Limits			Test Conditions	Unit
		Min.	Typ.	Max.		
t_{PLH}	Propagation Delay (2 levels)		15	25	$V_{CC} = 5.0 \text{ V}$	ns
t_{PHL}	Fig. 2		20	25		ns
t_{PLH}	Propagation Delay (3 levels)		20	30	$C_L = 15 \text{ pF}$	ns
t_{PHL}	Fig. 1		20	30		ns

AC WAVEFORMS

Figure 1.

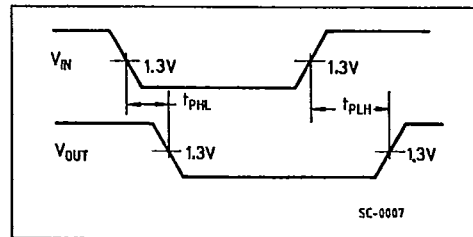

Figure 2.

T-66-21-57

