

TENTATIVE TOSHIBA BIPOLAR LINEAR INTEGRATED CIRCUIT SILICON MONOLITHIC

TA1248F

I/Q DEMODULATION IC FOR DIGITAL SATELLITE RECEIVER

FEATURES

- Supply voltage : 5V
- Second IF AGC amp
- dB-linear signal level amp
- Sync, quasi-sync detect PLL
- 90° phase shifter
- Baseband output amp
- HQFP30-P-1010 ideal for surface mounting

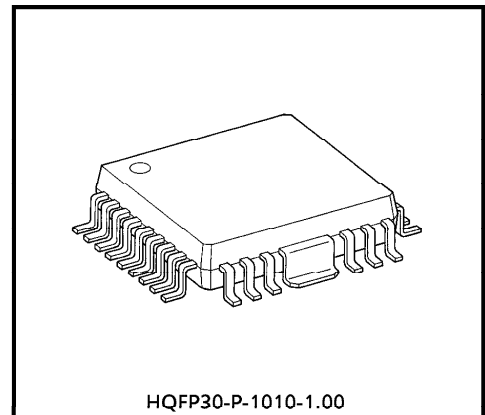

Weight : 0.61g (Typ.)

(Note) These devices are easy to be damaged by high static voltage or electric fields.
In regards to this, please handle with care.

961001EBA1

- TOSHIBA is continually working to improve the quality and the reliability of its products. Nevertheless, semiconductor devices in general can malfunction or fail due to their inherent electrical sensitivity and vulnerability to physical stress. It is the responsibility of the buyer, when utilizing TOSHIBA products, to observe standards of safety, and to avoid situations in which a malfunction or failure of a TOSHIBA product could cause loss of human life, bodily injury or damage to property. In developing your designs, please ensure that TOSHIBA products are used within specified operating ranges as set forth in the most recent products specifications. Also, please keep in mind the precautions and conditions set forth in the TOSHIBA Semiconductor Reliability Handbook.
- The products described in this document are subject to foreign exchange and foreign trade control laws.
- The information contained herein is presented only as a guide for the applications of our products. No responsibility is assumed by TOSHIBA CORPORATION for any infringements of intellectual property or other rights of the third parties which may result from its use. No license is granted by implication or otherwise under any intellectual property or other rights of TOSHIBA CORPORATION or others.
- The information contained herein is subject to change without notice.

BLOCK DIAGRAM

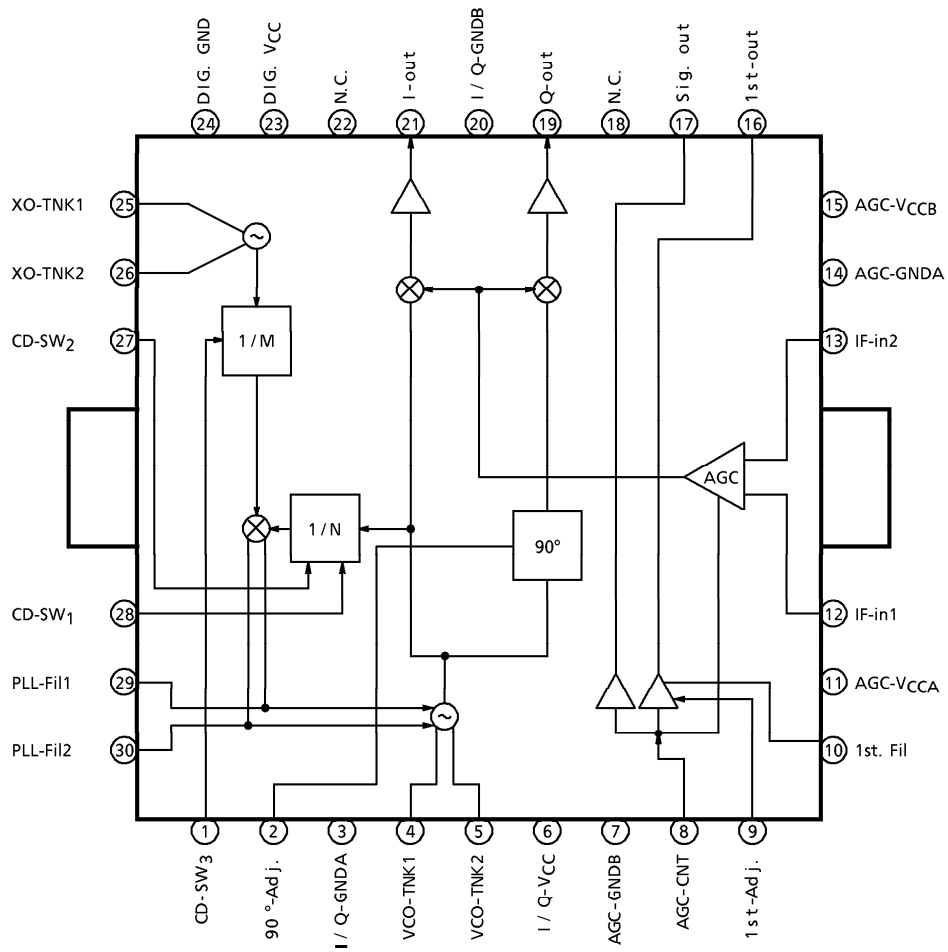







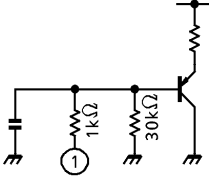
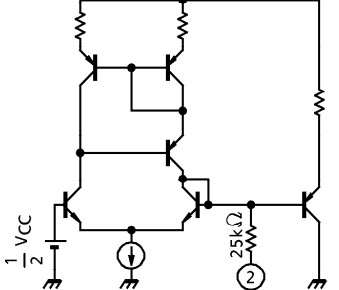
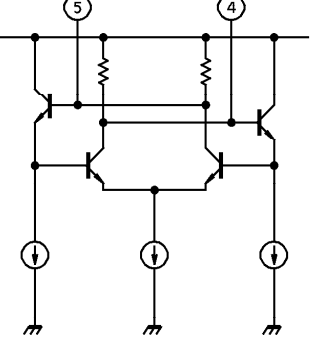
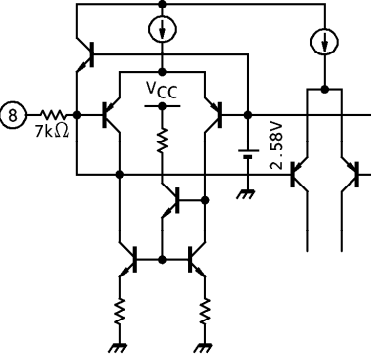

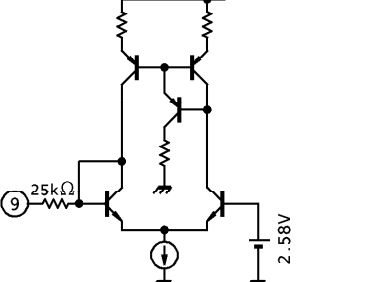
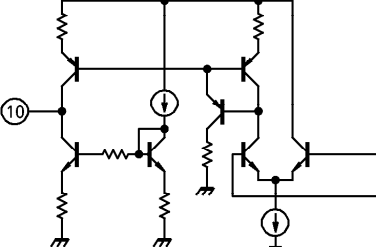
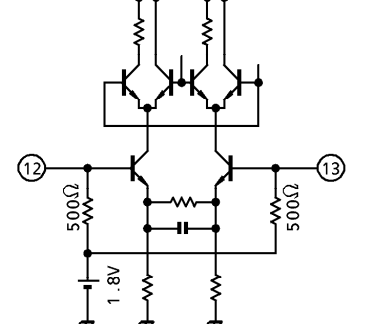
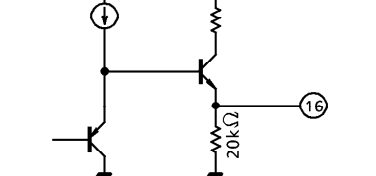
(Note 1) M : XO divider ratio (1/1, 1/2)

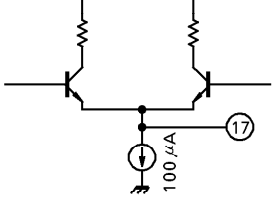
(Note 2) N : VCO divider ratio (1/32, 1/64, 1/128, 1/256)

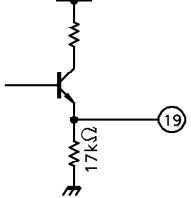
TERMINAL FUNCTIONS

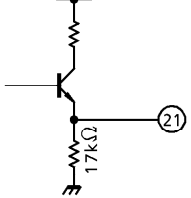
PIN No.	PIN NAME	FUNCTION	INTERFACE CIRCUIT						
1	XO divider ratio switch	Switches XO divider ratio. <table border="1" data-bbox="560 422 776 554"> <thead> <tr> <th>SW-3</th> <th>DIVIDER RATIO</th> </tr> </thead> <tbody> <tr> <td>0</td> <td>1/1</td> </tr> <tr> <td>1</td> <td>1/2</td> </tr> </tbody> </table> (Note) 0 : GND 1 : V _{CC} or open	SW-3	DIVIDER RATIO	0	1/1	1	1/2	
SW-3	DIVIDER RATIO								
0	1/1								
1	1/2								
2	90° phase shifter adjust pin	Fine-adjusts phase difference between I and Q outputs. IC internal bias is $\frac{1}{2}V_{CC}$.							
3	I/Q GND-A	I/Q block GND pin A	—						
4 5	VCO tank	VCO which uses internal impedance of diode corresponding to control voltage from PLL block. To compensate for internal temperature drift, use a capacitor with UJ characteristic for external tank circuit.							
6	I/Q V _{CC}	I/Q block power supply pin	—						
7	AGC GND-B	AGC block GND pin B	—						
8	AGC control pin	Gain changes according to applied voltage.							

PIN No.	PIN NAME	FUNCTIONS	INTERFACE CIRCUIT
9	First AGC delay point adjust pin	Because control signal is generated to previous stage second converter block of AGC circuit at excess input to IC, sets input level threshold.	
10	First AGC filter	Outputs the result of comparing AGC voltage with first AGC delay point voltage. The comparator is configured with an active load type high gain amp. The active low pass filter is constructed by the capacitance connected to this pin.	
11	AGC V _{CC} -A	AGC block power supply pin A	—
12 13	IF input pins	IF input pins. For unbalanced input, ground one of these pins via a capacitor.	
14	AGC GND-A	AGC block GND pin A	—
15	AGC V _{CC} -B	AGC block power supply pin B	—
16	First AGC output pin	Outputs control voltage via an emitter follower.	

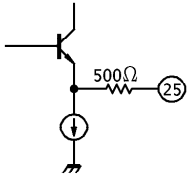
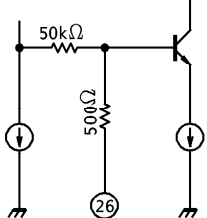
PIN No.	PIN NAME	FUNCTIONS	INTERFACE CIRCUIT
17	Signal level output pin	Outputs AGC voltage after conversion.	
18	N. C.	Leave this pin open.	
19	Q signal output	Q signal output pin	
20	I/Q GND-B	I/Q block GND pin B	
21	I signal output	I signal output pin	
22	N. C.	Leave this pin open.	
23	90° phase shifter V _{CC}	Power supply of 90° phase shifter block	
24	90° phase shifter GND	GND pin of 90° phase shifter block	
25	Crystal oscillator	Crystal oscillator used as reference for PLL operation. For external input, input from pin 26.	
26			

PIN No.	PIN NAME	FUNCTIONS	INTERFACE CIRCUIT															
27	VCO divider ratio switch 2	VCO divider switch pin <table border="1" style="display: inline-table; vertical-align: middle;"> <thead> <tr> <th>SW-1</th> <th>SW-2</th> <th>DIVIDER RATIO</th> </tr> </thead> <tbody> <tr> <td>0</td> <td>0</td> <td>1 / 32</td> </tr> <tr> <td>0</td> <td>1</td> <td>1 / 64</td> </tr> <tr> <td>1</td> <td>0</td> <td>1 / 128</td> </tr> <tr> <td>1</td> <td>1</td> <td>1 / 256</td> </tr> </tbody> </table> (Note) 0 : GND 1 : V _{CC} or open	SW-1	SW-2	DIVIDER RATIO	0	0	1 / 32	0	1	1 / 64	1	0	1 / 128	1	1	1 / 256	
SW-1	SW-2		DIVIDER RATIO															
0	0		1 / 32															
0	1		1 / 64															
1	0	1 / 128																
1	1	1 / 256																
28	VCO divider ratio switch 1																	
29	Loop filter	Low-pass filter for PLL block connecting pin																
30																		

MAXIMUM RATINGS (Ta = 25°C)

CHARACTERISTIC	SYMBOL	RATING	UNIT
Power Supply Voltage	V _{CC} MAX	6.0	V
Power Dissipation	P _D MAX	1080	mW
Operating Temperature	T _{opr}	-20~75	°C
Storage Temperature	T _{stg}	-55~150	°C

(Note) When using the device at above Ta = 25°C, decrease the power dissipation by 8.7mW for each increase of 1°C.

RECOMMENDED OPERATING CONDITION

PIN No.	PIN NAME	MIN.	TYP.	MAX.	UNIT
6	I/Q V _{CC}	4.5	5.0	5.5	V
11	AGC V _{CCA}	4.5	5.0	5.5	V
15	AGC V _{CCB}	4.5	5.0	5.5	V
23	DIG. V _{CC}	4.5	5.0	5.5	V

ELECTRICAL CHARACTERISTICS

DC CHARACTERISTICS (Unless otherwise specified, $V_{CC} = 5.0V$, $T_a = 25^\circ C$)

CHARACTERISTIC		SYMBOL	TEST CIRCUIT	TEST CONDITION	MIN.	TYP.	MAX.	UNIT
Power Supply And Current		I_{CC}	1	—	85	108	145	mA
Terminal Voltage	Pin 2	V_2	1	—	2.3	2.5	2.7	V
	Pin 4	V_4		(Note)	4.6	4.75	4.9	
	Pin 5	V_5		(Note)	4.6	4.75	4.9	
	Pin 8	V_8		—	2.3	2.5	2.7	
	Pin 9	V_9		—	2.3	2.5	2.7	
	Pin 10	V_{10}		—	4.4	4.65	4.9	
	Pin 12	V_{12}		—	1.5	1.8	2.1	
	Pin 13	V_{13}		—	1.5	1.8	2.1	
	Pin 16	V_{16}		—	3.8	4	4.2	
	Pin 17	V_{17}		—	1.3	1.65	2.0	
	Pin 19	V_{19}		—	1.2	1.7	2.2	
	Pin 21	V_{21}		—	1.2	1.7	2.2	
	Pin 25	V_{25}		—	2.4	2.7	3	
	Pin 26	V_{26}		—	1.9	2.1	2.3	
	Pin 29	V_{29}		—	2.0	2.3	2.6	
Pin 30	V_{30}	—	2.0	2.3	2.6			

(Note) When testing pins 4 and 5, connect pins 4 and 5, and pins 29 and 30.

AC CHARACTERISTICS (Unless otherwise specified, $V_{CC} = 5.0V$, $T_a = 25^\circ C$)

CHARACTERISTIC	SYMBOL	TEST CIR-CUIT	TEST CONDITION	MIN.	TYP.	MAX.	UNIT
IF Input Frequency Range	f_{in}	2	—	350	—	650	MHz
IF Input Level Range	v_{in}	—	For IF balanced input	- 56	—	- 21	dBmW
Gain Control Voltage (Max.)	V_{cmax}	2	(Note 1)	1.8	—	—	V
Gain Control Voltage (Min.)	V_{cmin}	2	(Note 2)	—	—	3.3	V
Gain Control Sensitivity	S gain	2	(Note 3)	—	—	65	dB / V
First AGC Delay Point	1st 25	2	(Note 4)	—	2.8	—	V
First AGC Maximum Delay Point	1st max	2	(Note 5)	—	3.2	—	V
First AGC Minimum Delay Point	1st min	2	(Note 6)	—	1.9	—	V
First AGC Delay Point Stability	1st A	2	(Note 7)	—	—	100	mV
First AGC Control Sensitivity	S 1st	2	(Note 8)	—	—	200	V / V
First AGC Maximum Output Voltage	1st V_{max}	2	(Note 9)	3.5	4	—	V
First AGC Minimum Output Voltage	1st V_{min}	2	(Note 10)	—	0.2	0.5	V
Signal Level Sensitivity	S sig	2	(Note 11)	—	1.67	—	V / V
Signal Level Maximum Output Voltage	SigV max	2	(Note 12)	3.5	—	—	V
Signal Level Minimum Output Voltage	SigV min	2	(Note 13)	—	—	1	V
Signal Level Output Stability	SigV A	2	(Note 14)	—	—	100	mV
VCO Lock Range	f_L	2	(Note 15)	± 1.5	—	—	MHz
VCO Capture Range	f_C	2	(Note 16)	± 3.5	—	—	MHz
Side band Rejection Level	f_S / I	2	(Note 17)	—	—	- 40	dBc
Phase Noise ($\Delta f = 100Hz$) ($\Delta f = 1kHz$) ($\Delta f = 10kHz$) ($\Delta f = 100kHz$) ($\Delta f = 1MHz$)	PN100	2	(Note 18)	—	—	- 60	dBc / Hz
	PN1k			—	—	- 70	dBc / Hz
	PN10k			—	—	- 80	dBc / Hz
	PN100k			—	—	- 90	dBc / Hz
	PN1M			—	—	- 100	dBc / Hz
I / Q Gain Balance	B gain	2	(Note 19)	—	—	± 1	dB
I / Q Phase Balance	B deg	2	(Note 20)	—	—	± 2	$^\circ$
Output Response	$f_{resp.}$	2	(Note 21)	—	—	± 1	dB
Output L_O Leakage	L L_O	2	(Note 22)	—	—	- 50	dBc
Tertiary Mutual Modulation Distortion	IM3	2	(Note 23)	—	—	- 30	dBc

TEST CONDITIONS

- (Note 1) Gain control voltage (Max.)
(1) Input $f=404.78\text{MHz}$, -50dBmW CW in pin 12.
(2) Monitor pin 19 using an oscilloscope.
(3) Supply DC voltage to pin 8 so that the output amplitude becomes $1V_{p-p}$.
(4) Measure the DC voltage at (3) above.
- (Note 2) Gain control voltage (Min.)
(1) Input $f=404.78\text{MHz}$, -20dBmW CW in pin 12.
(2) Monitor pin 19 using an oscilloscope.
(3) Supply DC voltage to pin 8 so that the output amplitude becomes $1V_{p-p}$.
(4) Measure the DC voltage at (3) above.
- (Note 3) Gain control sensitivity
(1) Input $f=404.78\text{MHz}$, -20dBmW CW in pin 12.
(2) Monitor pin 19 using an oscilloscope.
(3) Supply DC voltage to pin 8 so that the output amplitude becomes $1V_{p-p}$.
(4) Measure the DC voltage at (3) above.
(5) Input $f=404.78\text{MHz}$, -30dBmW CW in pin 12.
(6) Monitor pin 19 using an oscilloscope.
(7) Supply DC voltage to pin 8 so that the output amplitude becomes $1V_{p-p}$.
(8) Measure the DC voltage at (3) above.
(9) Calculate the sensitivity. $10 / [\text{Measured value at (4) above} - \text{measured value at (8) above}]$
- (Note 4) First AGC delay point
(1) Supply 2.5V DC to pin 9.
(2) Monitor pin 16 using a voltmeter.
(3) Supply between 1.8 and 3.3V DC to pin 8.
(4) Measure the pin 8 voltage when the pin 16 voltage drops to 3.5V or below.
- (Note 5) First AGC maximum delay point
(1) Supply 2.0V DC to pin 9.
(2) Monitor pin 16 using a voltmeter.
(3) Supply between 1.8 and 3.3V DC to pin 8.
(4) Measure the pin 8 voltage when the pin 16 voltage drops to 3.5V or below.
- (Note 6) First AGC minimum delay point
(1) Supply 3.7V DC to pin 9.
(2) Monitor pin 16 using a voltmeter.
(3) Supply between 1.8 and 3.3V DC to pin 8.
(4) Measure the pin 8 voltage when the pin 16 voltage drops to 3.5V or below.

- (Note 7) First AGC delay point stability
- (1) Supply 2.5V DC to pin 9.
 - (2) Monitor pin 16 using a voltmeter.
 - (3) Supply 2.5V DC to pin 8.
 - (4) Measure the pin 16 voltage.
 - (5) At -25°C or $+75^{\circ}\text{C}$ and $V_{CC}=4.5\text{V}$ or 5.5V , repeat from (1) to (4) above.
 - (6) Calculate the output stability. [Measured maximum value at (5) above – measured minimum value at (5) above]
- (Note 8) First AGC control sensitivity
- (1) Supply 2.5V DC to pin 9.
 - (2) Monitor pin 16 using a voltmeter.
 - (3) Supply 1.8 to 3.3V DC to pin 8.
 - (4) Measure the pin 8 and 16 voltages when the pin 16 voltage drops to 3.5V or below.
 - (5) Measure the pin 8 and 16 voltages when the pin 16 voltage drops to 1.0V or below.
 - (6) Calculate the output stability. $-\text{[Pin 16 at (4) above} - \text{pin 16 at (5) above]} / \text{[Pin 8 at (4) above} - \text{pin 8 at (5) above]}$
- (Note 9) First AGC maximum output voltage
- (1) Supply 2.5V DC to pin 9.
 - (2) Monitor pin 16 using a voltmeter.
 - (3) Supply 1.8V DC to pin 8.
 - (4) Measure the pin 16 voltage.
- (Note 10) First AGC minimum output voltage
- (1) Supply 2.5V DC to pin 9.
 - (2) Monitor pin 16 using a voltmeter.
 - (3) Supply 3.3V DC to pin 8.
 - (4) Measure the pin 16 voltage.
- (Note 11) Signal level sensitivity
- (1) Supply 2.5V DC to pin 9.
 - (2) Monitor pin 17 using a voltmeter.
 - (3) Supply 2.2V DC to pin 8.
 - (4) Measure the pin 17 voltage.
 - (5) Supply 2.6V DC to pin 8.
 - (6) Measure the pin 17 voltage.
 - (7) Calculate the sensitivity. $\text{[Measured value at (6) above} - \text{measured value at (4) above]} / 0.4$

- (Note 12) Signal level maximum output voltage
- (1) Supply 2.5V DC to pin 9.
 - (2) Monitor pin 17 using a voltmeter.
 - (3) Supply 3.3V DC to pin 8.
 - (4) Measure the pin 17 voltage.
- (Note 13) Signal level minimum output voltage
- (1) Supply 2.5V DC to pin 9.
 - (2) Monitor pin 17 using a voltmeter.
 - (3) Supply 1.8V DC to pin 8.
 - (4) Measure the pin 17 voltage.
- (Note 14) Signal level output stability
- (1) Supply 2.5V DC to pin 9.
 - (2) Monitor pin 17 using a voltmeter.
 - (3) Supply 2.5V DC to pin 8.
 - (4) Measure the pin 17 voltage.
 - (5) At -25°C or $+75^{\circ}\text{C}$ and $V_{CC} = 4.5\text{V}$ or 5.5V , repeat from (1) to (4) above.
 - (6) Calculate the output stability. [Measured maximum value at (5) above – measured minimum value at (5) above]
- (Note 15) VCO lock range
- (1) All of SW-1, SW-2 and SW-3 connect to GND.
 - (2) After connecting pins 29 and 30, adjust VCO L so that the desired oscillation frequency, f , is obtained.
 - (3) After disconnecting the crystal oscillator between pins 25 and 26, input frequency : $f/32$, amplitude : $1V_{p-p}$ sine wave signal f_{ref} to pin 26.
 - (4) Change the f_{ref} frequency in plus and minus directions and observe frequencies $[\pm\Delta f_{rck}]$ at the upper and lower limits where PLL lock is off.
 - (4) VCO lock range : $32 \times (\pm\Delta f_{rck})$
- (Note 16) VCO capture range
- (1) All of SW-1, SW-2 and SW-3 connect to GND.
 - (2) After connecting pins 29 and 30, adjust VCO L so that the desired oscillation frequency, f , is obtained.
 - (3) After disconnecting the crystal oscillator between pins 25 and 26, input frequency : $f/32$, amplitude : $1V_{p-p}$ sine wave signal f_{ref} to pin 26.
 - (4) Change, in the plus and minus directions, from a frequency sufficiently large compared with $[f_{ref} \pm \Delta f_{rck}]$ (PLL lock is off) to f_{ref} , the frequency of the signal input to pin 26. Observe frequencies $[\pm\Delta f_{pul}]$ at the upper and lower limits where PLL is locked.
 - (5) VCO capture range : $32 \times (\pm\Delta f_{pul})$

(Note 17) Side band rejection level

- (1) All of SW-1, SW-2 and SW-3 connect to GND.
- (2) Provide, with monitor coil (L), the VCO tank which is connected to pins 4 and 5.
- (3) After connecting pins 29 and 30, adjust VCO L so that the desired oscillation frequency, f , is obtained.
- (4) Observe oscillation strength P_{VCO} of the VCO spectrum using a spectrum analyzer.
- (5) Observe spectrum P_{sp} located at the frequency obtained by integer – multiplying the PLL compare reference frequency (12.587MHz).
- (6) Calculate $(P_{VCO} - P_{sp})$.

(Note 18) Phase noise

- (1) All of SW-1, SW-2 and SW-3 connect to GND.
- (2) Provide, with monitor coil (L), the VCO tank which is connected to pins 4 and 5.
- (3) After connecting pins 29 and 30, adjust VCO L so that the desired oscillation frequency, f , is obtained.
- (4) Observe oscillation strength P_{VCO} of the VCO oscillator spectrum using a spectrum analyzer.
- (5) Observe spectrum P_{noise} at a frequency which is Δf away from the oscillation frequency.
- (6) Calculate $(P_{VCO} - P_{noise}) / \Delta f$.

(Note 19) I/Q gain balance

- (1) Input $f = 417.78\text{MHz}$, -20dBmW CW to pin 12.
- (2) Monitor pin 19 using an oscilloscope.
- (3) Supply DC voltage to pin 8 so that the pin 19 output amplitude becomes $1V_{p-p}$.
- (4) Measure the amplitude ratio of pin 21 and pin 19.
- (5) Set the input level to -50dBmW and repeat (2) to (4) above.

(Note 20) I/Q phase balance

- (1) Input $f = 417.78\text{MHz}$, -20dBmW CW to pin 12.
- (2) Monitor pin 19 using an oscilloscope.
- (3) Supply DC voltage to pin 8 so that the pin 19 output amplitude becomes $1V_{p-p}$.
- (4) Measure the phase difference of pin 21 and pin 19.
- (5) Set the input level to -50dBmW and repeat (2) to (4) above.

- (Note 21) Output response
- (1) Input $f = 382.78\text{MHz}$, -20dBmW CW to pin 12.
 - (2) Monitor pin 19 using an oscilloscope.
 - (3) Supply DC voltage to pin 8 so that the pin 19 output amplitude becomes $1V_{p-p}$.
 - (4) While varying the input frequency from 382.78 to 422.78MHz, observe the output amplitude of pin 19.
 - (5) Calculate the gain deviation. $20\log$ [Measured value at (4) above / 1.0]
- (Note 22) Output L_O leakage
- (1) Input $f = 382.78\text{MHz}$, -54dBmW CW to pin 12.
 - (2) Monitor pin 19 using an oscilloscope.
 - (3) Supply DC voltage to pin 8 so that the pin 19 output amplitude becomes $1V_{p-p}$.
 - (4) Measure the pin 19 level using a spectrum analyzer.
 - (5) Measure the L_O signal (402.78MHz) level using the spectrum analyzer.
 - (6) Calculate the relative value against the pin 19 level. [Measured value at (4) above – measured value at (5) above]
- (Note 23) Tertiary mutual modulation distortion
- (1) Input the following two CW signals to pin 12.
 $f_1 = 404.78\text{MHz}$, -20dBmW
 $f_2 = 405.28\text{MHz}$, -20dBmW
 - (2) Monitor pin 19 using an oscilloscope.
 - (3) Supply DC voltage to pin 8 so that the pin 19 output amplitude becomes $1V_{p-p}$.
 - (4) Measure the pin 19 level using a spectrum analyzer.
 - (5) Measure the IM3 (spurious) level using the spectrum analyzer.
 - (6) Calculate the IM3 relative value. [Measured value at (5) above – measured value at (4) above]

TEST CIRCUIT 1
DC CHARACTERISTICS

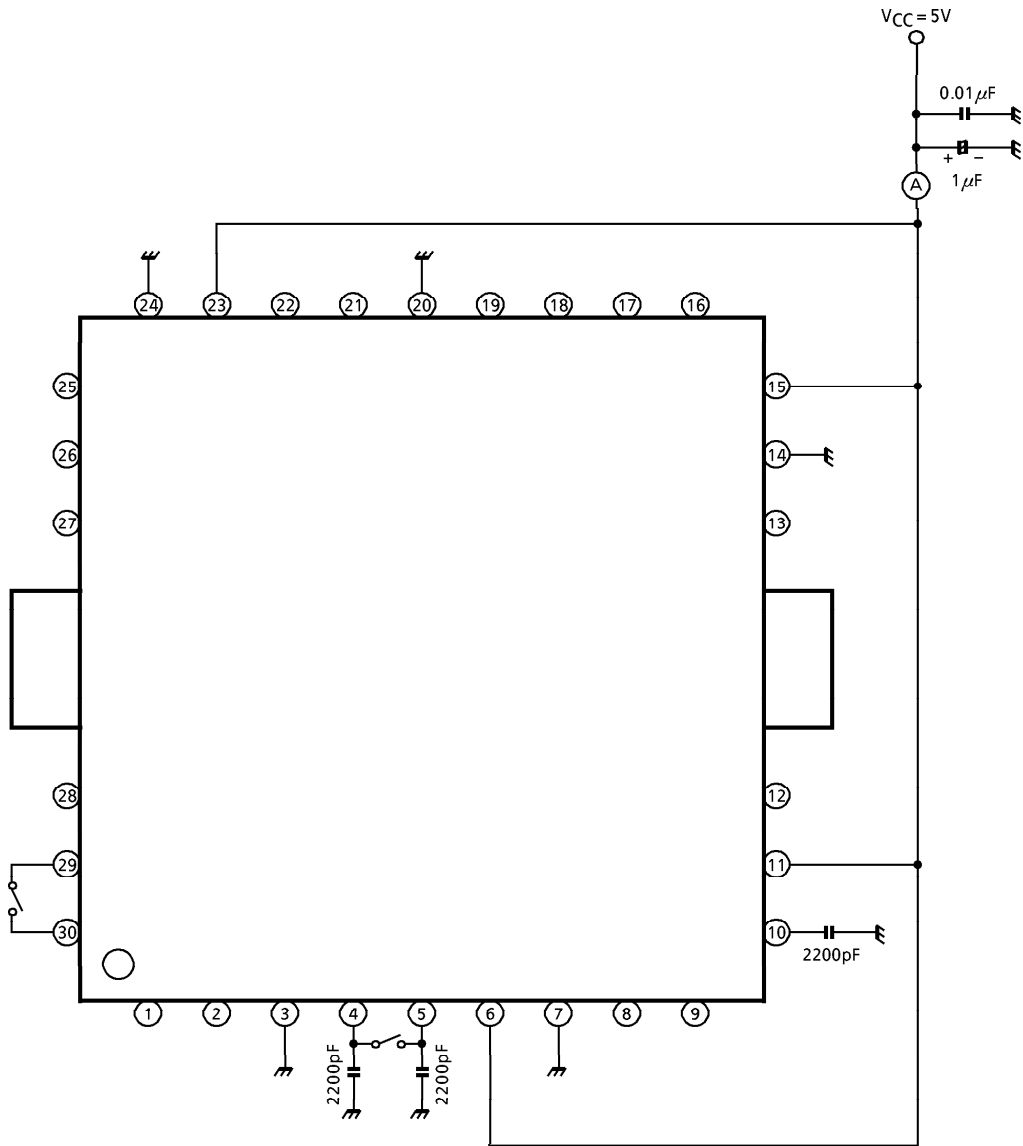

TEST CIRCUIT 2
AC CHARACTERISTICS
 (402.78MHz IF)

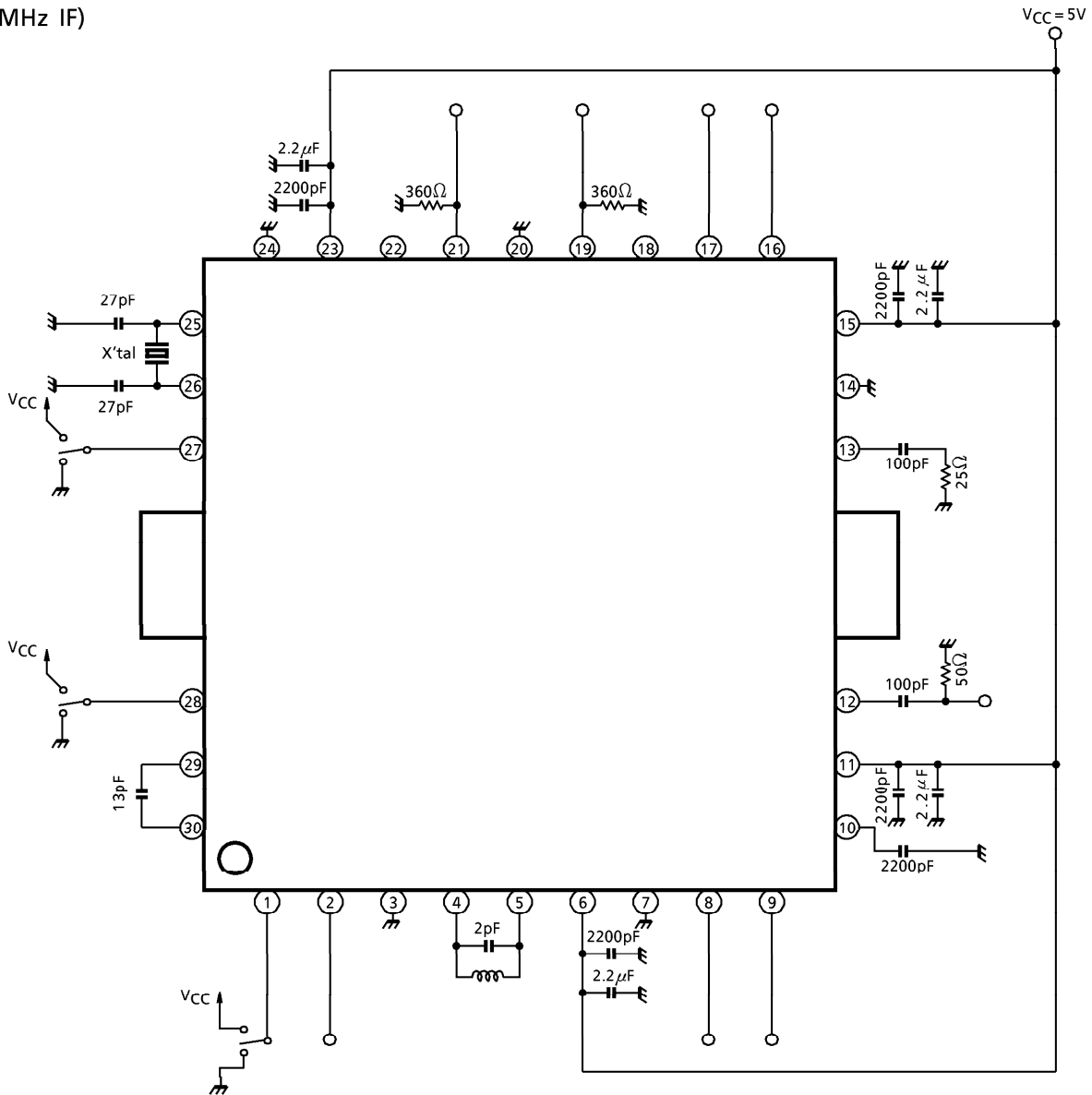

Crystal oscillator specifications

FREQUENCY [MHz]	FREQUENCY DEVIATION [ppm]	LOAD CAPACITANCE [pF]	EQUIVALENT SERIES RESISTANCE [Ω]	PARALLEL CAPACITANCE [pF]	TEMPERATURE
12,586875	± 30	10.0 ± 0.5	below 40	2.6 ± 0.5	- 25 ~ + 80°C

(*) Resonance condition : parallel

OUTLINE DRAWING
HQFP30-P-1010-1.00

Unit : mm

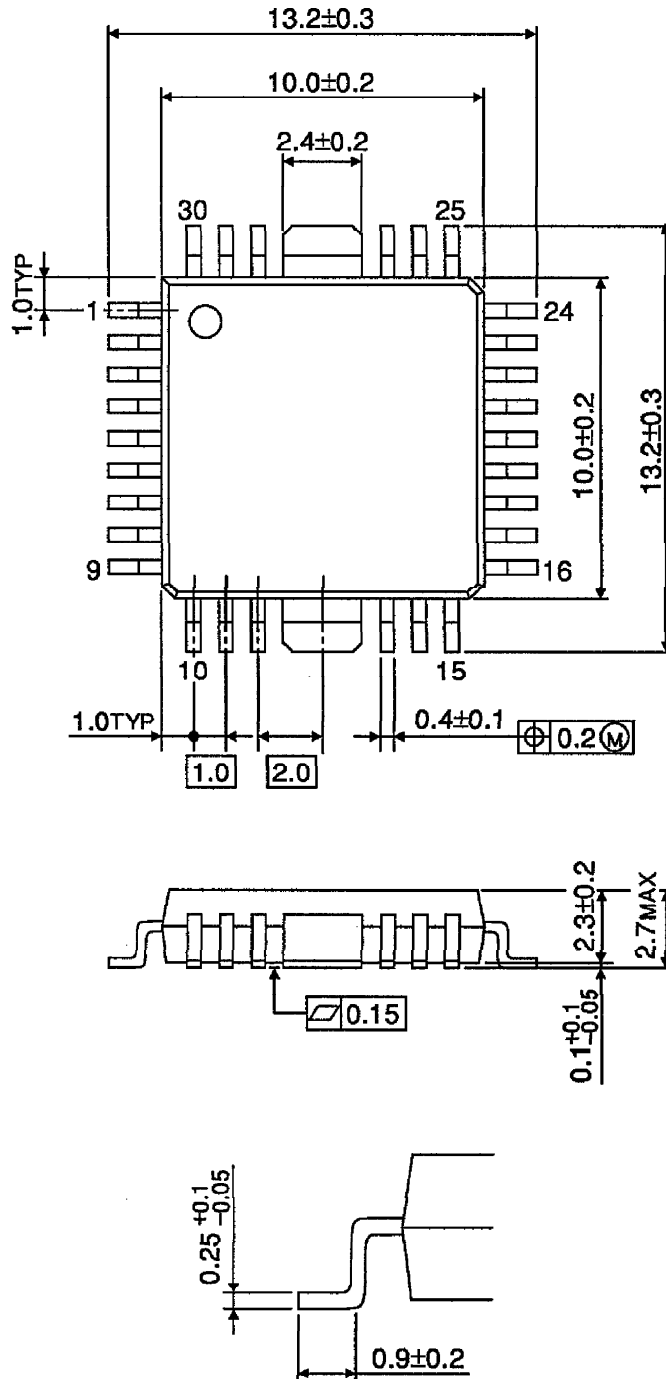

Weight : 0.61g (Typ.)