

TOSHIBA BIPOLAR LINEAR INTEGRATED CIRCUITS SILICON MONOLITHIC

**TA1249F****2-CHANNEL RECORDING AMPLIFIER & PRE-AMPLIFIER FOR VCR**

The TA1249F is a 2-channel recording amplifier and pre-amplifier for use in VCR. Since the recording amplifier uses a differential mechanism, it is particularly effective in reducing high-frequency even-ordered distortion. The pre-amplifier also has a differential mechanism and thus also reduces noise.

**FEATURES**

- Differential drive type recording amplifier
- Differential input type pre-amplifier
- Built-in envelope detector for auto-tracking
- Built-in recording mute circuit
- Board patterns can easily be shared, due to the high pin compatibility with the TA1250F 4-channel recording amplifier and pre-amplifier, and the TA1273F 6-channel recording amplifier and pre-amplifier.

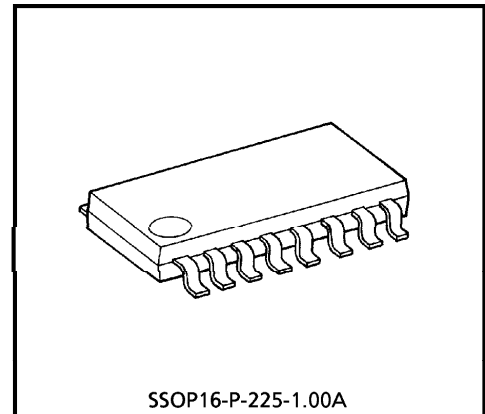

SSOP16-P-225-1.00A

Weight : 0.14g (Typ.)

980508EBA1

- TOSHIBA is continually working to improve the quality and the reliability of its products. Nevertheless, semiconductor devices in general can malfunction or fail due to their inherent electrical sensitivity and vulnerability to physical stress. It is the responsibility of the buyer, when utilizing TOSHIBA products, to observe standards of safety, and to avoid situations in which a malfunction or failure of a TOSHIBA product could cause loss of human life, bodily injury or damage to property. In developing your designs, please ensure that TOSHIBA products are used within specified operating ranges as set forth in the most recent products specifications. Also, please keep in mind the precautions and conditions set forth in the TOSHIBA Semiconductor Reliability Handbook.
- The products described in this document are subject to foreign exchange and foreign trade laws.
- The information contained herein is presented only as a guide for the applications of our products. No responsibility is assumed by TOSHIBA CORPORATION for any infringements of intellectual property or other rights of the third parties which may result from its use. No license is granted by implication or otherwise under any intellectual property or other rights of TOSHIBA CORPORATION or others.
- The information contained herein is subject to change without notice.

BLOCK DIAGRAM

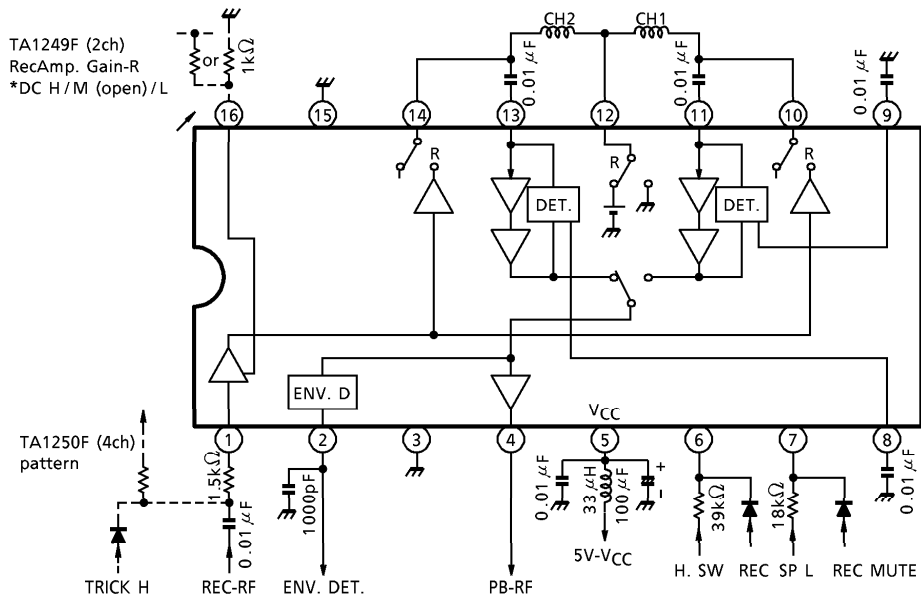

**PIN DESCRIPTIONS** ( $V_{CC} = 5.0V$ ,  $T_a = 25^\circ C$ )

PIN No.	FUNCTION	TYPICAL DC VOLTAGE	INTERFACE CIRCUIT	NOTES
1	Rec RF IN	0.9V		Current input type
2	ENV DET OUT	—		Pull-up used in Hi-Fi mode (Over 4.9V : Hi-Fi mode)
3	GND	(0V)	—	—
4	PB RF OUT	2V		Video : 0.3mV <sub>p-p</sub> input ↓ 60dB 300mV <sub>p-p</sub> output Hi-Fi : 0.15mV <sub>p-p</sub> input ↓ 67dB 336mV <sub>p-p</sub>
5	V <sub>CC</sub>	(5V)	—	—
6	H.SW / Rec H switching	2.5V		REC mode when TP6 is greater than 4.1V H.SW is current input type
7	SP / EP / Rec Mute switching	1.7V		V7 voltage L : SP H : EP TP7 voltage H : Red Mute
8	Filter 2	1.8V		DC return filter
9	Filter 1			
10	Rec OUT1	Open collector		—
14	Rec OUT2			

PIN No.	FUNCTION	TYPICAL DC VOLTAGE	INTERFACE CIRCUIT	NOTES
11	PB IN1	PB : 0.9V		—
13	PB IN2			
12	Head COMMON	Rec : 4.3V PB : 0.1V		—
15	Head GND	(0V)	—	—
16	Rec current gain switching	2.5V		Open : 2.5V Gain switching : H / M / V → 5V / 2.5V (OPEN) / 0V

**CONTROL TABLES**

HEAD switching

During PB	V <sub>6</sub> voltage	SP mode	EP mode	Hi-Fi mode
	H	2ch	2ch	2ch
	L	1ch	1ch	1ch

(Note) The above settings are controlled by the input and output currents.  
Pin 6 (TP6) has function of Rec H too.

MODE switching

V <sub>7</sub> voltage	Mode
L	SP
H (OPEN)	EP

(Note) Pin 7 has function of Rec Mute too. When pin 7 (TP7) is raised to H (V<sub>CC</sub>), then Rec Mute mode is set.

Switching of Rec current gain is performed at pin 16.

Pin 16 voltage	Gain
H	3.5dB
M (OPEN)	0dB
L	-6dB

(Note) Uses M-level voltage at pin 16 as reference.

## EXAMPLES OF REC CURRENT SETTING

- When used in video mode

Input : 500mV<sub>p-p</sub>, 4MHz

PIN 1 INPUT RESISTANCE	REC CURRENT GAIN	REC CURRENT (SINGLE-CHANNEL OUTPUT)
1k $\Omega$	M	17.7mA
	L	8.89mA
1.5k $\Omega$	H	17.8mA
	M	11.8mA
	L	5.93mA

- When used in Hi-Fi mode

Input : 700mV<sub>p-p</sub>, 2MHz

PIN 1 INPUT RESISTANCE	REC CURRENT GAIN	REC CURRENT (SINGLE-CHANNEL OUTPUT)
2k $\Omega$	H	24.8mA
	M	16.6mA
	L	8.3mA
3k $\Omega$	H	16.5mA
	M	11.0mA

## MAXIMUM RATINGS (Ta = 25°C)

CHARACTERISTIC	SYMBOL	RATING	UNIT
Power Supply Voltage	V <sub>CC</sub>	7	V
Power Dissipation 1	P <sub>D1</sub> (Note 1)	378	mW
Power Dissipation 2	P <sub>D2</sub> (Note 2)	780	mW
Input Voltage	V <sub>IN</sub>	GND - 0.3~V <sub>CC</sub> + 0.3	V
Operating Temperature	T <sub>opr</sub>	-20~75	°C
Storage Temperature	T <sub>stg</sub>	-55~150	°C

(Note 1) Derated linearly above Ta = 25°C in the proportion of 3mW/°C.

(Note 2) On the board mounting (Glass epoxy 50×50×1.6mm, Area of copper : 40%)  
Derated linearly above Ta = 25°C in the proportion of 6.3mW/°C.

## RECOMMENDED POWER SUPPLY VOLTAGE RANGE

Power supply voltage : 4.5~5.5V, 5V (typical)

**ELECTRICAL CHARACTERISTICS** ( $V_{CC} = 5V$ ,  $T_a = 25^\circ C$ )

VIDEO SYSTEM  
PB mode

CHARACTERISTIC	SYMBOL	TEST CIR-CUIT	TEST CONDITION	MIN.	TYP.	MAX.	UNIT
Power Supply Current	Iccp	—	—	21	27	33	mA
Voltage Gain	G1	—	Input (V11, V13) : f = 1MHz, 0.3mV <sub>p-p</sub>	57	60	63	dB
	G2	—					
Voltage Gain Difference	ΔG	—	G1 – G2	-0.5	0	0.5	dB
frequency Characteristic	GF1	—	Input (V11, V13) : 0.3mV <sub>p-p</sub> Output ratio 8M / 1M	-1.5	0.5	2.5	dB
	GF2	—					
secondary Harmonic Distortion	HD1	—	Input (V11, V13) : 0.3mV <sub>p-p</sub> Power ratio 8M / 4M	—	-50	-45	dB
	HD2	—					
Maximum Output Voltage	V <sub>om1</sub>	—	Input (V11, V13) : f = 1MHz ; level when thirdly harmonic distortion of output reaches -30dB.	2.0	2.2	—	V <sub>p-p</sub>
	V <sub>om2</sub>						
Crosstalk	CR1	—	Input (V11, V13) : f = 4MHz, 0.3mV <sub>p-p</sub> Level difference between channels	—	-38	-35	dB
	CR2						
Output DC Offset	ΔVODC	—	CH1 – CH2	-15	0	15	mV
Eguated Input Noise	N1	—	Measurement point 4MHz RBW : 10kHz	—	0.1	—	μV <sub>rms</sub>
	N2						
ENV-Det (SP Mode)	VENVS1	—	Input (V11, V13) : f = 4MHz, 50μV <sub>p-p</sub>	0.4	0.7	1.0	V
	VENVS2	—	Input (V11, V13) : f = 4MHz, 1mV <sub>p-p</sub>	2.95	3.35	3.75	
ENV-Det (EP Mode)	VENVE1	—	Input (V11, V13) : f = 4MHz, 50μV <sub>p-p</sub>	0.8	1.1	1.4	V
	VENVE2	—	Input (V11, V13) : f = 4MHz, 1mV <sub>p-p</sub>	3.4	3.8	4.2	

Rec mode (Input resistance : 1.5kΩ)

CHARACTERISTIC	SYMBOL	TEST CIR-CUIT	TEST CONDITION	MIN.	TYP.	MAX.	UNIT
Power Supply Current	Iccr	—	—	52	63	79	mA
Current Gain	GrH1	—	Input : f = 1MHz, 500mV <sub>p-p</sub> Pin 16 pull-up (Rec Gain : High)	33.8	34.3	34.8	dB
	GrH2						
	GrM1	—	Input : f = 1MHz, 500mV <sub>p-p</sub> Pin 16 open (Rec Gain : Middle)	30.3	30.8	31.3	
	GrM2						
	GrL1	—	Input : f = 1MHz, 500mV <sub>p-p</sub> Pin 16 pull-down (Rec Gain : Low)	24.4	24.9	25.4	
GrL2							
Frequency Characteristic	Grf1	—	Input : 500mV <sub>p-p</sub> , pin 16 open Output ratio 8M / 1M	-1.5	0	1.5	dB
	Grf2						
Secondary Harmonic Distortion	HDR1	—	f = 4MHz, 500mV <sub>p-p</sub> , Output ratio 8M / 4M	—	-50	-45	dB
	HDR2						

CONTROL SYSTEM

CHARACTERISTIC	SYMBOL	TEST CIR-CUIT	TEST CONDITION	MIN.	TYP.	MAX.	UNIT
Rec Mute	Mute1	—	Mute ON (TP7)	4.2		5.0	V
	Mute2	—	Mute OFF (TP7)	0.0		3.4	
Rec / PB	R / P1	—	Rec mode (TP6)	4.0		5.0	V
	R / P2	—	PB mode (TP6)	0.0		2.8	
SP / EP	EPS1	—	SP mode (V7)	0.0		0.6	V
	EPS2	—	EP mode (V7)	1.5		5.0	
1CH / 2CH	SWP1	—	1CH (V6)	0.0		1.5	V
	SWP2	—	2CH (V6)	3.5		5.0	
Pin 16 Gain Change	GH	—	High	4.0		5.0	V
	GL	—	Low	0.0		1.0	
Video / Hi-Fi	VH1	—	Video mode (TP2)	0.0		4.3	V
	VH2	—	Hi-Fi mode (TP2)	4.9		5.0	

Hi-Fi SYSTEM (Input resistance : 2K $\Omega$ )

CHARACTERISTIC	SYMBOL	TEST CIR-CUIT	TEST CONDITION	MIN.	TYP.	MAX.	UNIT
Power Supply Current (PB)	Icchp	—	—	22	28	36	mA
Power Supply Current (Rec)	Icchr	—	—	63	77	96	mA
Voltage Gain (PB)	GHP1	—	Input (V11, V13) : 1MHz, 0.15mV <sub>p-p</sub>	64	67	70	dB
	GHP2						
Current Gain (Rec)	GHRH1	—	Input : f = 1.5MHz, 700mV <sub>p-p</sub> Rec Gain : High	36.8	37.3	37.8	dB
	GHRH2						
	GHRM1	—	Input : f = 1.5MHz, 700mV <sub>p-p</sub> Rec Gain : Middle	33.3	33.8	34.3	
	GHRM2						
	GHRL1	—	Input : f = 1.5MHz, 700mV <sub>p-p</sub> Rec Gain : Low	27.4	27.9	28.4	
	GHRL2						
Frequency Characteristic (PB)	GHf1	—	Input (V11, V13) : 0.15mV <sub>p-p</sub> Output ratio 3M / 1M	-0.3	0.2	0.7	dB
	GHf2						
Frequency Characteristic (Rec)	GHrf1	—	Input : 700mV <sub>p-p</sub> Output ratio 3M / 1M	-0.6	0	0.4	dB
	GHrf2						
Secondary Harmonic Distortion (PB)	HDrf1	—	Input (V11, V13) : 2MHz, 0.15mV <sub>p-p</sub> Ratio 4M / 2M	—	-60	-45	dB
	HDrf2						
Secondary Harmonic Distortion (Rec)	HDRf1	—	Input : 2MHz, 700mV <sub>p-p</sub> Ratio 4M / 2M	—	-50	-45	dB
	HDRf2						
Intermodulation Distortion	CMD1	—	Input : 700mV <sub>p-p</sub> (R) + 221 mV <sub>p-p</sub> (L) L : f = 1.3MHz, R : f = 1.7MHz, L/R ratio : -10dB	—	-45	-40	dB
	CMD2						
Crosstalk	CRH1	—	Input (V11, V13) : f = 2MHz, 0.15mV <sub>p-p</sub> Level difference between channels	—	-38	-36	dB
	CRH2						

TEST CIRCUIT

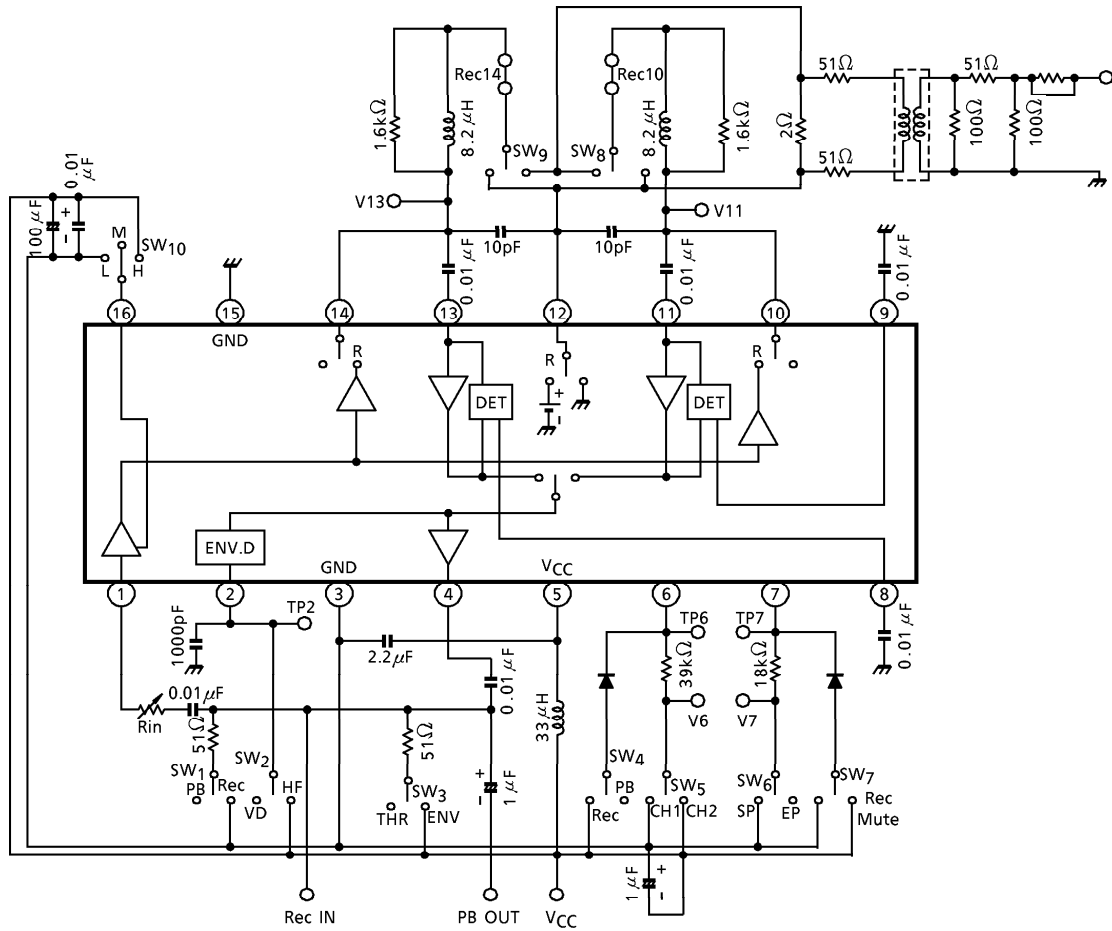



**OUTLINE DRAWING**  
SSOP16-P-225-1.00A

Unit : mm

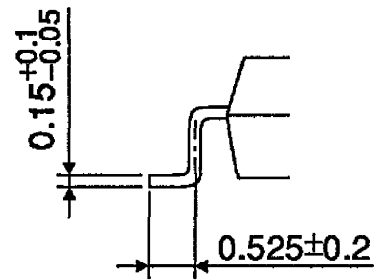
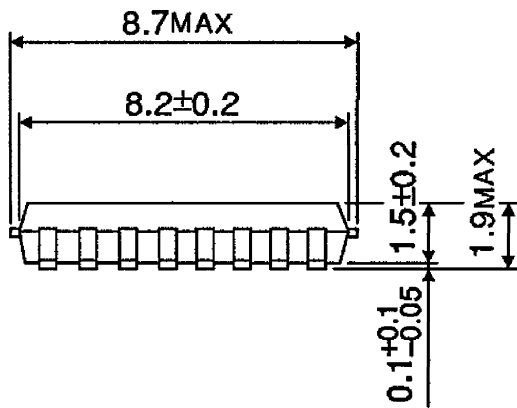
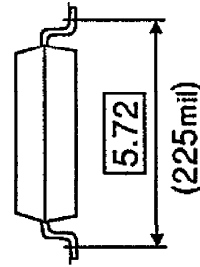
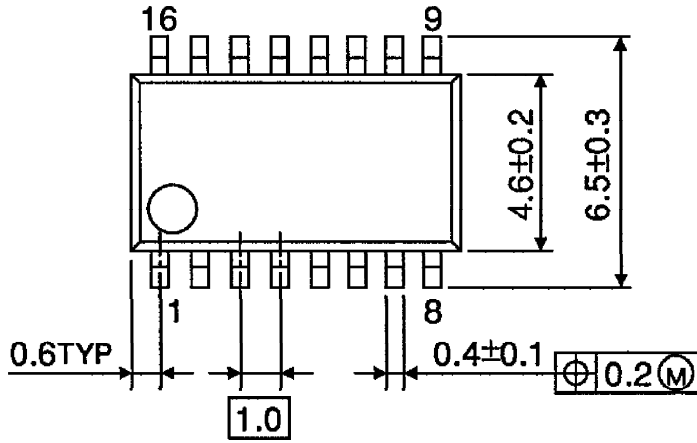

Weight : 0.14g (Typ.)