

TOSHIBA BIPOLAR LINEAR INTEGRATED CIRCUIT SILICON MONOLITHIC

# TA1272AF

FOR LCD TVS, PIF AND SIF SYSTEM

## FEATURES

PIF circuit

- High input sensitivity
- 3-stage variable-gain PIF amplifier
- Output with black noise inverter
- Output without black noise inverter
- High-speed response peak AGC with dual time constant
- Reverse RF AGC output
- Built-in AFT detection circuit with AFT mute

SIF circuit

- 4-stage SIF amplifier
- Quadrature-type detection circuit

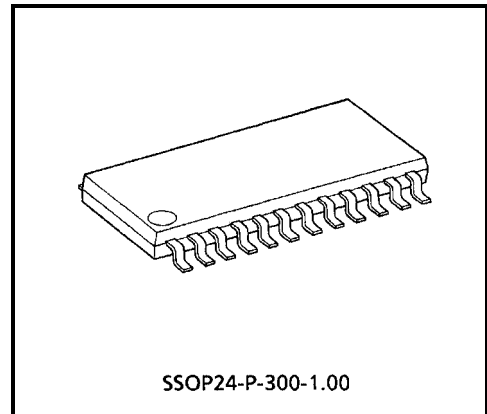

Weight: 0.32g (Typ.)

## RF AGC CURVE

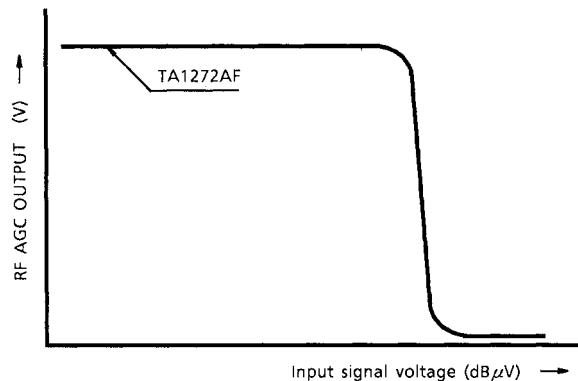

000707EBA1

• TOSHIBA is continually working to improve the quality and reliability of its products. Nevertheless, semiconductor devices in general can malfunction or fail due to their inherent electrical sensitivity and vulnerability to physical stress. It is the responsibility of the buyer, when utilizing TOSHIBA products, to comply with the standards of safety in making a safe design for the entire system, and to avoid situations in which a malfunction or failure of such TOSHIBA products could cause loss of human life, bodily injury or damage to property.

In developing your designs, please ensure that TOSHIBA products are used within specified operating ranges as set forth in the most recent TOSHIBA products specifications. Also, please keep in mind the precautions and conditions set forth in the "Handling Guide for Semiconductor Devices," or "TOSHIBA Semiconductor Reliability Handbook" etc..

• The TOSHIBA products listed in this document are intended for usage in general electronics applications (computer, personal equipment, office equipment, measuring equipment, industrial robotics, domestic appliances, etc.). These TOSHIBA products are neither intended nor warranted for usage in equipment that requires extraordinarily high quality and/or reliability or a malfunction or failure of which may cause loss of human life or bodily injury ("Unintended Usage"). Unintended Usage include atomic energy control instruments, airplane or spaceship instruments, transportation instruments, traffic signal instruments, combustion control instruments, medical instruments, all types of safety devices, etc.. Unintended Usage of TOSHIBA products listed in this document shall be made at the customer's own risk.

• The products described in this document are subject to the foreign exchange and foreign trade laws.

• The information contained herein is presented only as a guide for the applications of our products. No responsibility is assumed by TOSHIBA CORPORATION for any infringements of intellectual property or other rights of the third parties which may result from its use. No license is granted by implication or otherwise under any intellectual property or other rights of TOSHIBA CORPORATION or others.

• The information contained herein is subject to change without notice.

## BLOCK DIAGRAM

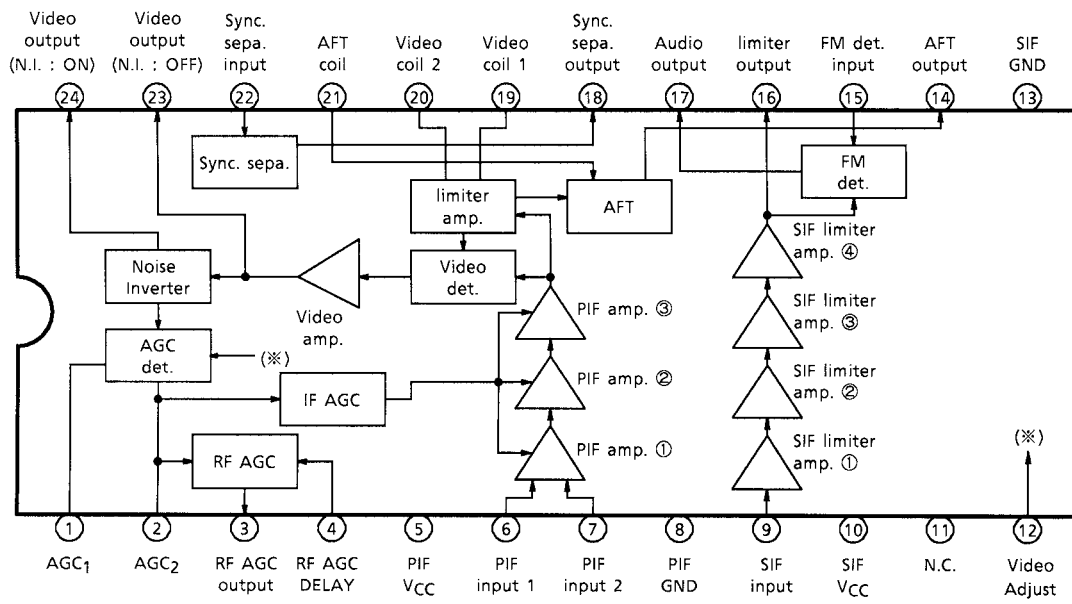

**TERMINAL FUNCTION**

PIN No.	PIN NAME	FUNCTION	INTERFACE
1 2	PIF AGC <sub>1</sub> PIF AGC <sub>2</sub>	This IC is adopted dual time constant AGC circuit to improve AGC responsibility. To mute picture, connect 1.6 kΩ between pin 1 and GND.	
3	RF AGC Output	RF AGC output terminal (open-collector output)	
4	RF AGC Delay	Changing comparator reference voltage adjusts RF AGC delay point.	
5	PIF V <sub>CC</sub>	Connect bypass capacitor between this terminal and PIF GND with shortest wiring.	—
6 7	PIF Input 1 PIF Input 2	PIF input terminal. Input impedance 5 kΩ (Typ.)	
8	PIF GND	Connect bypass capacitor between this terminal and PIF V <sub>CC</sub> with shortest wiring.	—

PIN No.	PIN NAME	FUNCTION	INTERFACE
9	SIF Input	Connect BPF between this terminal and pin 23.	
10	SIF V <sub>CC</sub>	Connect bypass capacitor between this terminal and SIF GND with shortest wiring.	—
11	N.C.	—	—
12	Video Adjust	Video signal output voltage adjustment terminal. Changing this terminal voltage, it is possible to adjust video signal output voltage to 1.0 V <sub>p-p</sub> . (In case of use on adjustment free, connect resistor (330 kΩ) (*) to GND.) To prevent noise, connecting capacitor (0.01 μF) to GND is recommended. (*resistance tolerance : ±5%)	
13	SIF GND	Connect bypass capacitor between this terminal and SIF V <sub>CC</sub> with shortest wiring.	—
14	AFT Output	AFT detector output terminal based on double balanced multiplier. AFT output is muted when AFT coil terminal is connected to GND.	

PIN No.	PIN NAME	FUNCTION	INTERFACE
15	FM Det. Input	Quadrature input terminal for FM detection circuit. Connect FM coil between this terminal and pin 16. Audio output is muted when this terminal is connected to GND.	
17	Audio Output	Audio signal output terminal.	
16	Limiter Output	Limiter output terminal. Connect FM coil between this terminal and pin 15.	
18 22	Sync. Sepa.	Sync. sepa. output and input terminal.	
19 20	Video Coil 1 Video Coil 2	Connect video detection coil.	

PIN No.	PIN NAME	FUNCTION	INTERFACE
21	AFT Coil	Connect AFT detection coil. AFT output is defeated when this terminal connected to GND.	
23 24	Video Output 1 Video Output 2	Video signal output terminal. Pin 23 is the output without noise inverter, and can thus be used for diversity circuit, for example. Pin 24 is the output with noise inverter.	

## MAXIMUM RATINGS (Ta = 25°C)

CHARACTERISTIC	SYMBOL	RATING	UNIT
Power Supply Voltage	V <sub>CC</sub>	8	V
Power Dissipation	P <sub>D</sub> (Note)	500	mW
Operating Temperature	T <sub>opr</sub>	-20~65	°C
Storage Temperature	T <sub>stg</sub>	-55~150	°C

Note: When using the device at above Ta = 25°C, decrease the power dissipation by 4 mW for each increase of 1°C.

## RECOMMENDED POWER SUPPLY

PIN No.	PIN NAME	MIN	TYP.	MAX	UNIT
5	PIF V <sub>CC</sub>	3.5	4.5	5.5	V
9	SIF V <sub>CC</sub>	3.5	4.5	5.5	V

## ELECTRIC CHARACTERISTICS (Unless otherwise specified, V<sub>CC</sub> = 4.5 V, Ta = 25°C)

### DC CHARACTERISTICS

PIN No.	PIN NAME	FUNCTION	MIN.	TYP.	MAX.	UNIT
1	AGC <sub>1</sub>	1st AGC filter	—	4.2	—	V
2	AGC <sub>2</sub>	2nd AGC filter	—	4.2	—	
3	RF AGC	RF AGC output	—	—	—	
4	RF AGC delay	RF AGC delay	—	—	—	
5	PIF V <sub>CC</sub>	PIF V <sub>CC</sub>	—	4.5	—	
6	PIF input 1	IF input	2.5	2.9	3.2	
7	PIF input 2	IF input	2.5	2.9	3.2	
8	PIF GND	PIF GND	—	0	—	
9	SIF input	SIF input	4.3	4.45	4.6	
10	SIF V <sub>CC</sub>	SIF V <sub>CC</sub>	—	4.5	—	
11	N.C.	—	—	—	—	
12	Video Adjust	Video Adjust	0.55	0.85	1.15	
13	SIF GND	SIF GND	—	0	—	
14	AFT output	AFT output	1.3	1.8	3.2	
15	FM det. input	FM det. output	3.5	3.7	3.9	
16	Limiter output	SIF limiter output	2.55	2.75	2.95	
17	Audio output	Audio signal output	1.7	2.1	2.5	
18	Sync. sepa. output	Sync. sepa. signal output	—	—	—	
19	Video coil 1	PIF carrier output	4.05	4.15	4.25	
20	Video coil 2	PIF carrier output	4.05	4.15	4.25	
21	AFT coil	Connecting AFT coil	4.35	4.45	4.55	
22	Sync. sepa. input	Sync. sepa. signal output	—	—	—	
23	Video output 1	Video signal output (noise inverter : OFF)	1.40	1.85	2.30	
24	Video output 2	Video signal output (noise inverter : ON)	1.40	1.85	2.30	

## AC CHARACTERISTICS (Unless otherwise specified, $V_{CC} = 4.5\text{ V}$ , $T_a = 25^\circ\text{C}$ ) PIF circuit

CHARACTERISTIC	SYMBOL	TEST CIRCUIT	CONDITION	MIN.	TYP.	MAX.	UNIT
Power Supply Current at No Signal	$I_{PIF}$	1	—	—	11	16	mA
Output Signal Voltage	$V_D$	2	(Note 1)	0.8	1.0	1.2	$V_{p-p}$
PIF Input Signal Voltage Sensitivity	$V_{i\text{ MIN}}$	2	(Note 2)	—	43	50	$\text{dB}\mu\text{V}$
Maximum input Signal Voltage	$V_{i\text{ MAX}}$	2	(Note 3)	95	114	—	$\text{dB}\mu\text{V}$
-3 dB Video Band Width	BW	2	(Note 4)	5	6.5	—	MHz
Dependence of Output Signal Voltage On Power Supply Voltage	$V_D / V_{CC}$	2	(Note 5)	—	$\pm 5$	—	% / V
Deferential Gain	DG	3	(Note 6)	—	5	10	%
Deferential Phase	DP			—	4	8	$^\circ$
Signal-Noise Ratio	S / N	2	(Note 7)	40	45	—	dB
Intermodulation	IM	4	(Note 8)	30	35	—	dB
Suppression of Picture Career	CR	2	(Note 9)	45	50	—	dB
Sync. Voltage Level	$V_p$	2	White 100%	0.5	0.75	1.0	V
Output Voltage at No Signal	$V_z$	2	(Note 10)	1.6	2.0	2.4	V
Black Noise Inverter Level	$V_{BTH}$	2	(Note 11) Video output 2	0.4	0.6	0.8	V
Black Noise Clamp Level	$V_{BCL}$			1.0	1.2	1.4	
AFT Control Steepness	$\Delta f / \Delta V$	2	Load : 75 k $\Omega$ / 75 k $\Omega$	10	20	30	kHz / V
AFT maximum Output Voltage	$V_{MAX}$			4.0	4.3	4.5	V
AFT minimum Output Voltage	$V_{MIN}$			—	0.3	0.5	
AFT Mute Voltage	$V_{MUTE}$			2.1	2.25	2.4	



## SIF circuit

CHARACTERISTIC	SYMBOL	TEST CIR-CUIT	CONDITION	MIN	TYP.	MAX	UNIT
Power Supply Current at No Signal	I <sub>SIF</sub>	1	—	—	6	11	mA
Output Signal Voltage	V <sub>OD</sub>	2	(Note 12)	120	150	180	mV <sub>rms</sub>
SIF Input Signal Voltage Sensitivity	V <sub>LIM</sub>	2	(Note 13)	30	35	40	dB $\mu$ V
Total Harmonic Distortion	THD (DET)	2	(Note 14)	—	0.4	1.0	%
AM Rejection	AMR	5	(Note 15)	30	45	—	dB
Signal-Noise Ratio	S / N DET	2	(Note 16)	50	65	—	dB
-3 dB Bandwidth	BW-3 dB	2	(Note 17)	180	230	—	kHz
Dependence of Output Signal Voltage On Power Supply Voltage	V <sub>OD</sub> / V <sub>CC</sub>	2	(Note 18)	—	10	15	% / V

## Sync. sepa. circuit

CHARACTERISTIC	SYMBOL	TEST CIR-CUIT	CONDITION	MIN	TYP.	MAX	UNIT
Sync. Sepa. input Voltage	V <sub>SYNC.IN</sub>	2	—	1.8	2.1	3.0	V
Sync. Sepa. Minimum Output Voltage	V <sub>SYNC.MIN</sub>	2	Load : 47 k $\Omega$	0	0.2	0.4	V
Sync. Sepa. Maximum Output Voltage	V <sub>SYNC.MAX</sub>	2		4.3	4.5	—	V

## TEST CONDITION

<PIF circuit>

- Note 1: Output signal voltage  
PIF input :  $f_0 = 58.75$  MHz, 87.5%AM, 84 dB $\mu$ V, White 100%  
Measure output video signal voltage.
- Note 2: PIF input signal voltage sensitivity  
PIF input :  $f_0 = 58.75$  MHz,  $f_m = 15.75$  kHz, 30%AM, 84 dB $\mu$ V  
Measure output video signal voltage (that voltage is 0 dB) Lower input signal voltage gradually, measure input PIF signal voltage when output video signal voltage is -3 dB.
- Note 3: Maximum input signal voltage  
PIF input :  $f_0 = 58.75$  MHz,  $f_m = 15.75$  kHz, 30%AM, 84 dB $\mu$ V  
Measure output video signal voltage (that voltage is 0 dB) Raise input signal voltage gradually, measure input PIF signal voltage when output video signal voltage is +3 dB
- Note 4: -3 dB video band width  
(1) PIF input :  
 $f_0 = 58.75$  MHz, 84 dB $\mu$ V, CW  
Measure IF AGC voltage and supply that voltage from external source.  
(2) Input following composite signals to the PIF input :  

SG : 1	$58.75$ MHz, 84 dB $\mu$ V (frequency : fixed)
SG : 2	$58.65 \sim 45$ MHz, 64 dB $\mu$ V (frequency : variable)

 Monitor spectrum of output signal at pin 24. Change frequency of SG : 2, measure frequency of SG : 2, when video output signal is -3 dB.  
Difference between that frequency and 58.75 MHz is -3 dB band width.
- Note 5: Dependence of output signal voltage on power supply voltage  
PIF input :  $f_0 = 58.75$  MHz, 87.5%AM, 84 dB $\mu$ V, standard TV signal (V / S = 10 : 4 Ramp)  
Measure the output video signal voltage when power supply voltage are 3.5 V and 5.5 V. ( $4.5 \pm 1.0$  V)  
Compare those voltage and the output video signal voltage when power supply voltage is 4.5 V.
- Note 6: Deferential gain / Deferential phase  
PIF input :  $f_0 = 58.75$  MHz, 87.5%AM, 84 dB $\mu$ V, standard TV signal (V / S = 10 : 4 Ramp) IF AGC : free  
Measure deferential gain and deferential phase.
- Note 7: Signal-noise ratio  
(1) PIF input :  $f_0 = 58.75$  MHz,  $f_m = 15.75$  kHz, 30%AM, 84 dB $\mu$ V  
Measure IF AGC voltage and supply that voltage from external source.  
(2) Measure output video signal voltage. :  $V_1$   
(3) PIF input :  $f_0 = 58.75$  MHz, 84 dB $\mu$ V, CW  
Measure output video signal voltage. :  $V_2$   
Signal-noise ratio is calculated by following equality.  
Signal-noise ratio =  $20 \log (V_1 \times 6 / V_2)$  [dB]
- Note 8: Intermodulation  
(1) PIF input :  $f_0 = 58.75$  MHz, 84 dB $\mu$ V, CW  
Supply DC voltage to IF AGC from external source to fix IF AGC voltage.  
(2) PIF input : following composite signals  

$f_0 = 58.75$ MHz, 84 dB $\mu$ V, CW	} Input
$f_c = 55.17$ MHz, 74 dB $\mu$ V, CW	
$f_s = 54.25$ MHz, 74 dB $\mu$ V, CW	

 Measure the difference of signal level at pin 24 920 kHz component and 3.58 MHz component (Chroma sub-carrier).
- Note 9: Suppression of picture career  
(1) PIF input :  $f_0 = 58.75$  MHz,  $f_m = 15.75$  kHz, 78%AM, 84 dB $\mu$ V  
Measure IF AGC voltage and supply that voltage from external source.  
(2) Measure output video signal voltage. :  $V_1$   
(3) PIF input :  $f_0 = 58.75$  MHz, 84 dB $\mu$ V, CW  
Measure signal level of 58.75 MHz component at pin 24. :  $V_2$   
Signal-noise ratio is calculated by following equality.  
Suppression of picture career =  $20 \times \log (V_1 / V_2)$  [dB]

- Note 10: Output voltage at no signal  
PIF input : no input IF AGC : GND  
Measure output video signal DC voltage.
- Note 11: Black noise inverter level / Black noise clamp level  
PIF input :  $f_0 = 58.75$  MHz,  $f_m = 15.75$  kHz, 78%AM, 84 dB $\mu$ V  
Supply 0V to IF AGC from external source. Raise that voltage gradually, measure black noise inverter level.
- <SIF circuit>
- Note 12: Output signal voltage  
SIF input :  $f_0 = 4.5$  MHz,  $f_m = 400$  Hz, 25 kHz / devi, 84 dB $\mu$ V  
Measure output audio signal voltage.
- Note 13: SIF input signal voltage sensitivity  
SIF input :  $f_0 = 4.5$  MHz,  $f_m = 400$  Hz, 25 kHz / devi, 84 dB $\mu$ V  
Measure output audio signal voltage (that voltage is 0 dB). Lower input SIF signal voltage gradually, measure input SIF signal voltage when output audio signal voltage is -3 dB.
- Note 14: Total harmonic distortion  
SIF input :  $f_0 = 4.5$  MHz,  $f_m = 400$  Hz, 7.5 kHz / devi, 84 dB $\mu$ V
- Note 15: AM Rejection  
SIF input :  
(1) FM :  $f_0 = 4.5$  MHz,  $f_m = 400$  Hz, 25 kHz / devi, 84 dB $\mu$ V  
(2) AM :  $f_0 = 4.5$  MHz,  $f_m = 400$  Hz, 30%AM, 84 dB $\mu$ V  
Measure difference of output audio signal voltage between (1) and (2).
- Note 16: Signal-noise ratio  
SIF input :  $f_0 = 4.5$  MHz,  $f_m = 400$  Hz, 25 kHz / devi, 84 dB $\mu$ V  
Measure audio signal output voltage. :  $V_1$  [mV $_{rms}$ ]  
SIF input :  $f_0 = 4.5$  MHz,  $f_m = 400$  Hz, 25 kHz / devi, 84 dB $\mu$ V  
Measure audio signal output voltage. :  $V_2$  [mV $_{rms}$ ]  
Signal-noise ratio is calculated by following equality.  
Signal-noise ratio =  $20 \log (V_1 / V_2)$  [dB]
- Note 17: -3 dB bandwidth  
SIF input :  $f_0 = 4.5$  MHz,  $f_m = 400$  Hz, 25 kHz / devi, 84 dB $\mu$ V  
Measure audio signal output voltage. (that voltage is 0 dB) Then change input signal frequency, measure bandwidth that audio signal output voltage within -3 dB.
- Note 18: Dependence of output signal voltage on power supply voltage  
SIF input :  $f_0 = 4.5$  MHz,  $f_m = 400$  Hz, 25 kHz / devi, 84 dB $\mu$ V  
Measure the audio signal output voltage when power supply voltage are 3.5 V and 5.5 V. (4.5  $\pm$  1.0 V)  
Compare those voltage and audio signal output voltage when power supply voltage is 4.5 V.

## TEST CIRCUIT 1 (DC CHARACTERISTIC)

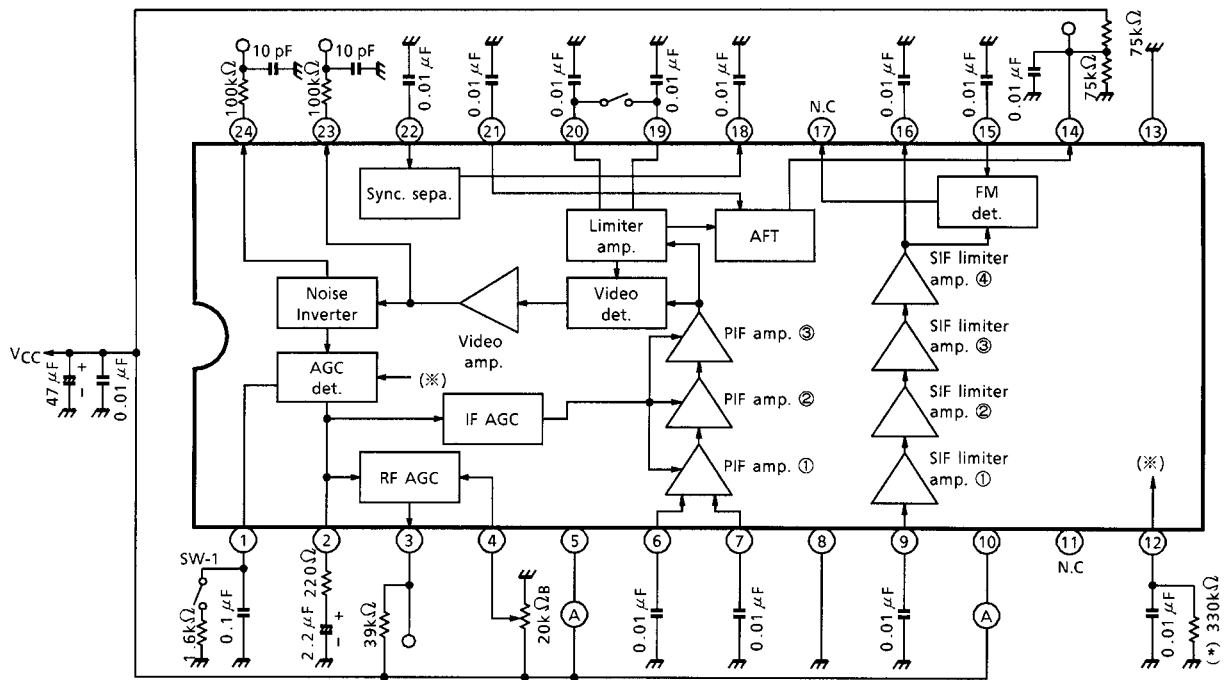

**TEST CIRCUIT 2 (AC CHARACTERISTIC)**

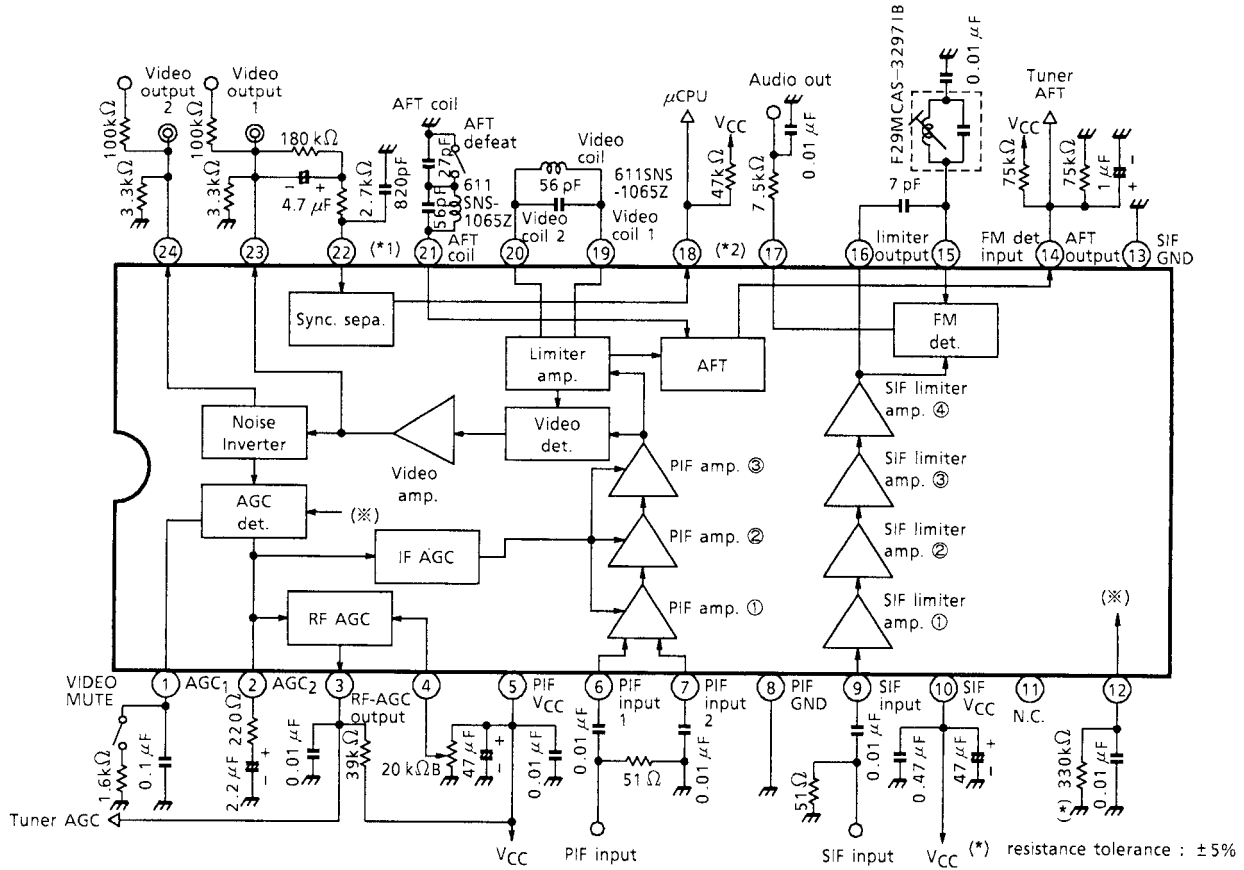

(\*1) Sync. sepa. input  
 (\*2) Sync. sepa. output

**TEST CIRCUIT 3 (DG, DP)**

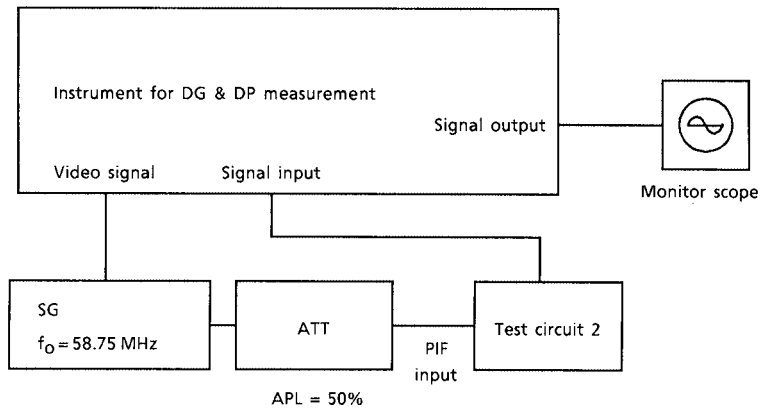

**TEST CIRCUIT 4 (INTERMODULATION)**

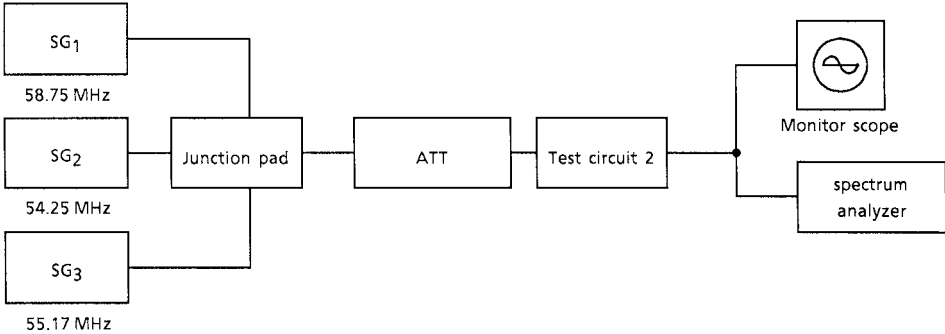

**TEST CIRCUIT 5 (AMR)**

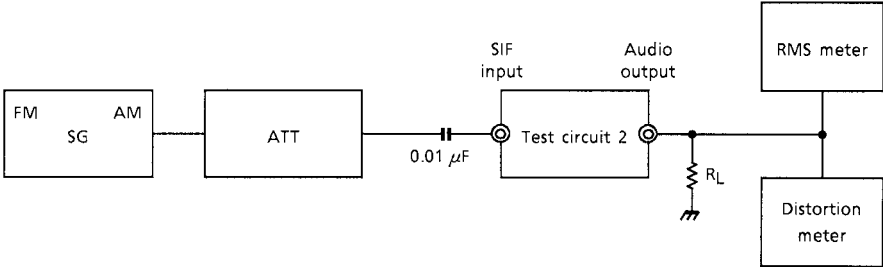

## COIL ADJUSTMENT

- Video coil  
 Measure video signal output DC voltage.  
 IF AGC : Fix voltage for external voltage source /  
 PIF input : 58.75MHz, 84dB $\mu$ V, CW  
 Adjust video coil so that video signal output DC voltage is lowest.
- ATF coil  
 Measure video signal output AFT voltage.  
 PIF input : 54~62MHz (seep signal), 84 dB $\mu$ V  
 Adjust AFT coil so that AFT output signal is following figure.

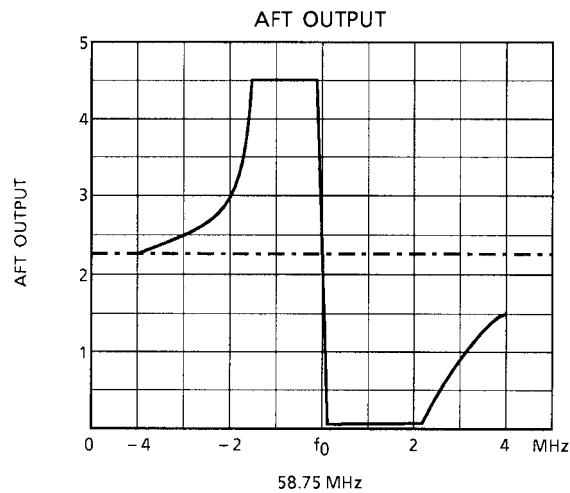

**COILE SPECIFICATION**

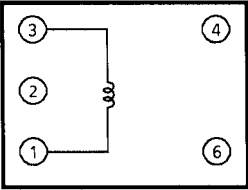
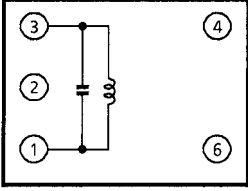
COIL NAME	PART NUMBER	CONNECTION	SPECIFICATION
Video AFT	611SNS-1065Z (TOKO)		Center frequency : 58.75 MHz Internal capacitor : — External capacitor : — Frequency adjustment range : ±4% Qu : 72 ± 20% Size : 5 mm × 5 mm
FM	F29MCAS-32971B (TOKO)		Center frequency : 4.5 MHz Internal capacitor : 100 pF Demodulation output : 77 mV ± 10 mV (STD) Tuning frequency : 4.467 MHz ± 11 kHz or above (STD) 3dB bandwidth : 4.467 MHz ± 75 kHz or above (STD) Size : 7 mm × 7 mm

**APPLICATION CIRCUIT**

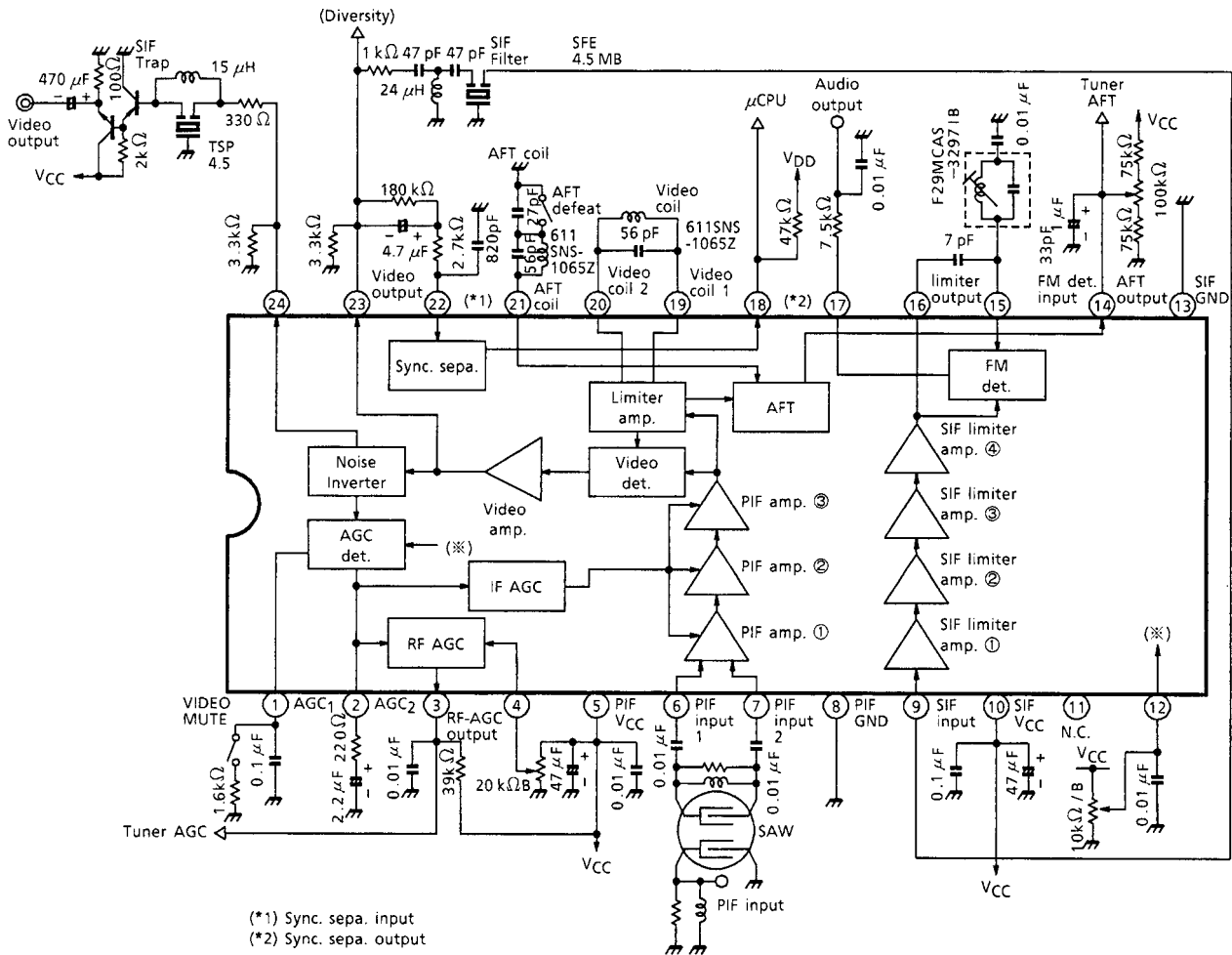



## PACKAGE DIMENSIONS

SSOP24-P-300-1.00

Unit : mm

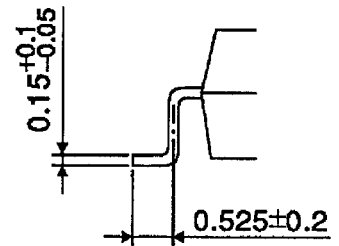
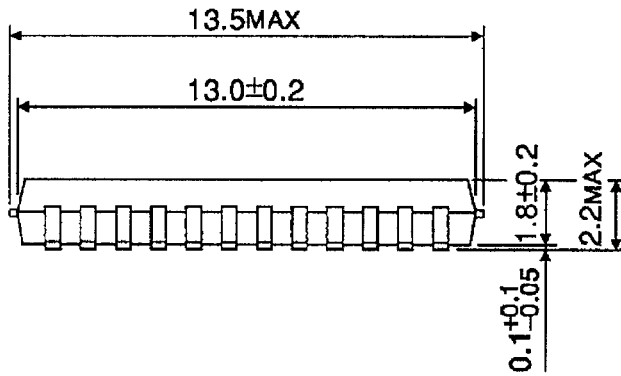
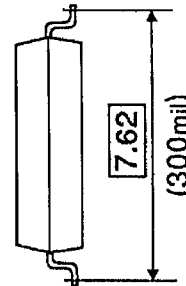
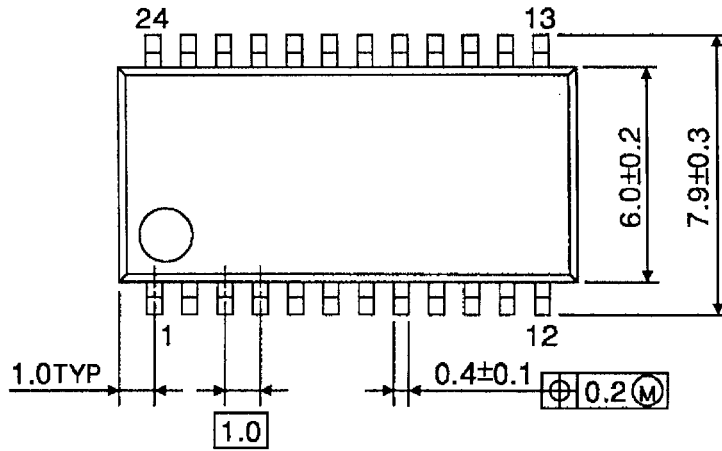

Weight: 0.32g (Typ.)