

Toshiba Bipolar Linear IC - Silicon Monolithic

TA1319AP/AF

Switched Mode Power Supply (SMPS) Controller IC

The TA1319AP/AF is a switched mode power supply (SMPS) controller IC that is capable of switching from high frequency PWM (pulse width modulation) mode to low frequency mode to reduce power consumption during standby. This IC can build power supplies that contribute to power consumption savings for electronic appliances that run at 50 W or lower during operation such as video cassette records, DVD players, facsimile machines and printers.

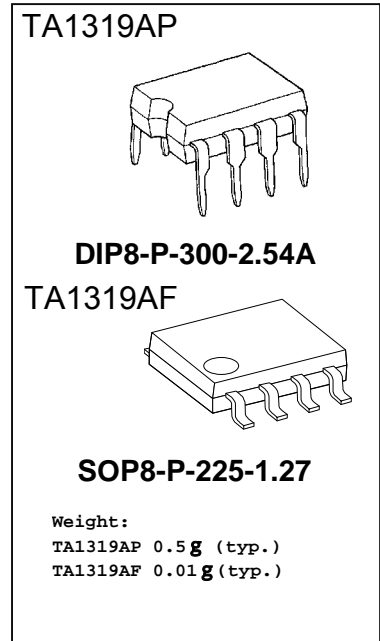

Features

- Equipped with low frequency PWM mode and high frequency PWM mode for effectively reducing power consumption during standby conditions.
- The switch to standby mode is made when the FB voltage input to pin 4 (FB IN) exceeds the set voltage. The set voltage is determined by pin 3 (STB).
- OPP (Over Power Protection: Lowers the OCL threshold when the input AC voltage is high.)
UVLO (Under Voltage Lock Out),
OVLO (Over Voltage Lock Out) latch function equipped,
OCL (Over Current Limiter)
- Wide AC range compatible (85 V to 264 V)
- Drive frequency setting range: 25 kHz to 150 kHz

RESTRICTIONS ON PRODUCT USE

000707EBA

- TOSHIBA is continually working to improve the quality and reliability of its products. Nevertheless, semiconductor devices in general can malfunction or fail due to their inherent electrical sensitivity and vulnerability to physical stress. It is the responsibility of the buyer, when utilizing TOSHIBA products, to comply with the standards of safety in making a safe design for the entire system, and to avoid situations in which a malfunction or failure of such TOSHIBA products could cause loss of human life, bodily injury or damage to property.
In developing your designs, please ensure that TOSHIBA products are used within specified operating ranges as set forth in the most recent TOSHIBA products specifications. Also, please keep in mind the precautions and conditions set forth in the "Handling Guide for Semiconductor Devices," or "TOSHIBA Semiconductor Reliability Handbook" etc..
- The TOSHIBA products listed in this document are intended for usage in general electronics applications (computer, personal equipment, office equipment, measuring equipment, industrial robotics, domestic appliances, etc.). These TOSHIBA products are neither intended nor warranted for usage in equipment that requires extraordinarily high quality and/or reliability or a malfunction or failure of which may cause loss of human life or bodily injury ("Unintended Usage"). Unintended Usage include atomic energy control instruments, airplane or spaceship instruments, transportation instruments, traffic signal instruments, combustion control instruments, medical instruments, all types of safety devices, etc.. Unintended Usage of TOSHIBA products listed in this document shall be made at the customer's own risk.
- The products described in this document are subject to the foreign exchange and foreign trade laws.
- The information contained herein is presented only as a guide for the applications of our products. No responsibility is assumed by TOSHIBA CORPORATION for any infringements of intellectual property or other rights of the third parties which may result from its use. No license is granted by implication or otherwise under any intellectual property or other rights of TOSHIBA CORPORATION or others.
- The information contained herein is subject to change without notice.

Block Diagram

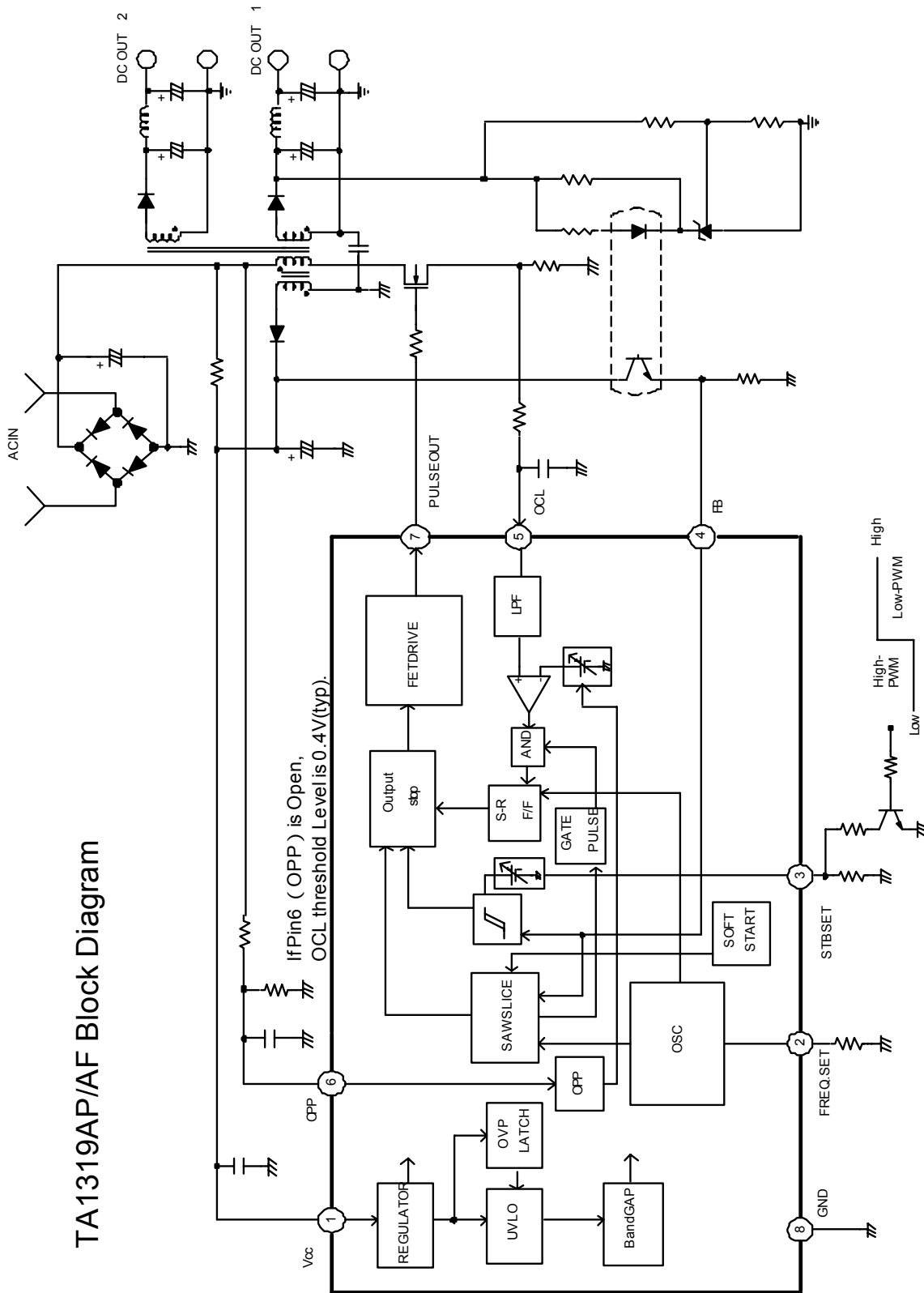

Functional Description

- Low Frequency/Steady State Continuous Switching Method

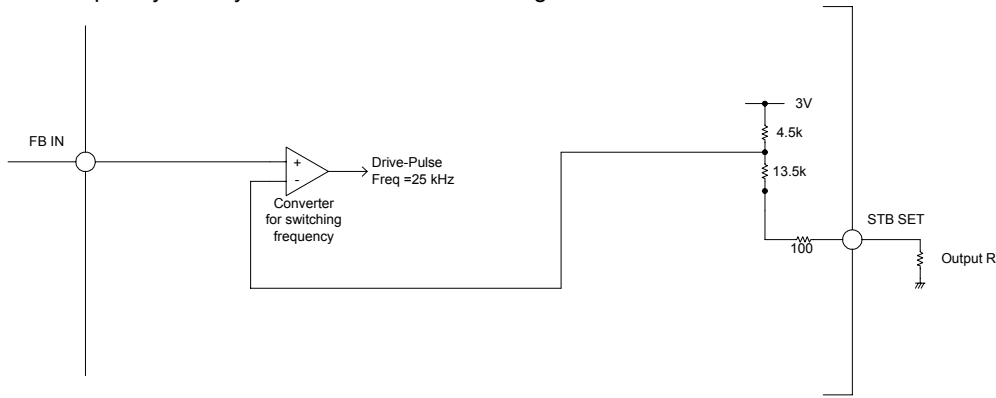

Figure 1. Block Diagram of Control Mode Switching Location

The TA1319 IC is equipped with a low frequency continuous mode to lower the oscillation frequency during low load conditions to reduce loss during standby. The STB pin resistance sets the voltage used to make the transition from steady state continuous mode to low frequency continuous mode. Since the FB IN pin's voltage grows larger as the load gets lighter, the IC controls are configured to make a mode transition when the FB voltage rises above the set voltage determined by the resistance connected to the STB pin.

Specifically, the threshold level setting for switching and selecting modes based on external resistance is as shown below.

STB Pin External Resistance	FB IN Pin Voltage Switching Point V1
1.5 kΩ	Approximately 2.31 V
5.6 kΩ	Approximately 2.43 V
27 kΩ	Approximately 2.70 V

The following formula can be used to extrapolate the FB IN pin voltage setting used as the switching point by calculating the external resistance as R (kΩ).

$$V1 = (13.6+R) / (18.1+R) \times 3$$

● **Additional Explanation in Regard to the Mode Switching Control Function**

The FB IN voltage increases as the load gets lighter. Taking advantage of this fact, the IC controls switch to standby mode when the STB pin's voltage exceeds the set voltage.

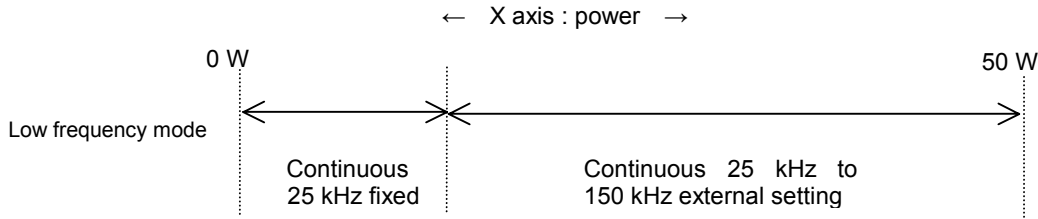

The switching point can be adjusted at will using the external resistance of pin 3 (STB SET).

● **Low Frequency Continuous Mode Switching Control**

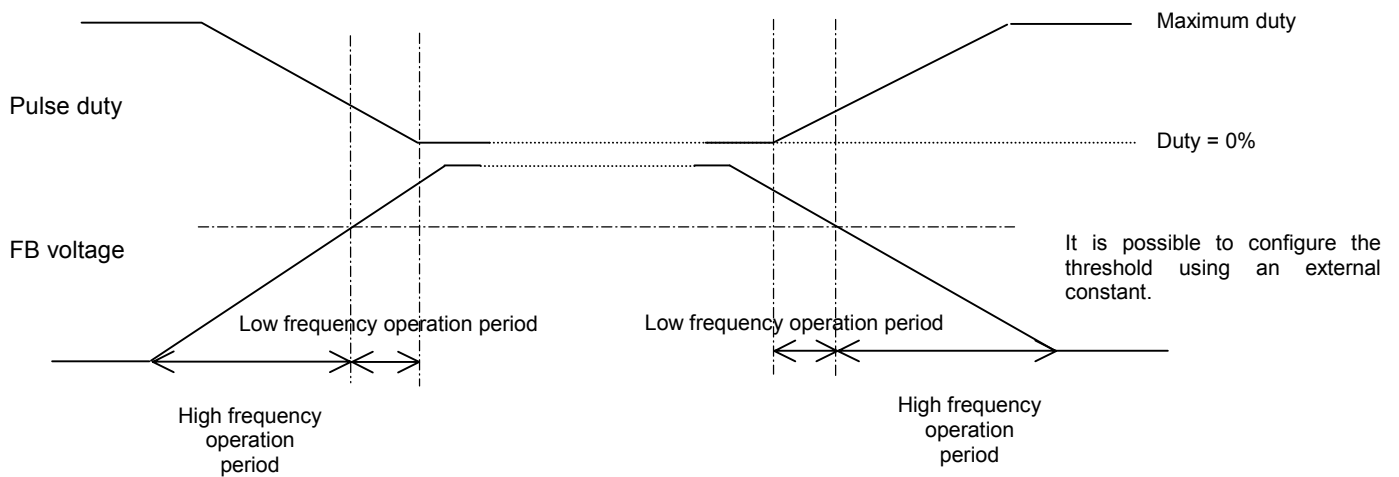

● **OPP (Over Power Protection)**

The OPP causes the OCL converter's reference voltage to vary with the input voltage and actuates the OCL in regard to power that exceeds the set current level.

Specifically, the AC voltage drawn into pin 6 (OPP) is monitored using the resistance pressure. This function works to lower the OCL threshold the higher pin-6's voltage goes. Therefore, the higher the AC voltage, the lower the OCL threshold.

This function makes it possible to avert the condition of the OCL becoming sluggish the higher the AC voltage rises.

Be sure to use a condenser rated to around 0.01 μF even if you choose not to use this function, as there is the possibility of malfunction due to noise entering pin 6.

In addition, if pin 6 is left open (no external voltage flowing into pin 6), the OCL threshold is fixed to 0.41 V (typ.).

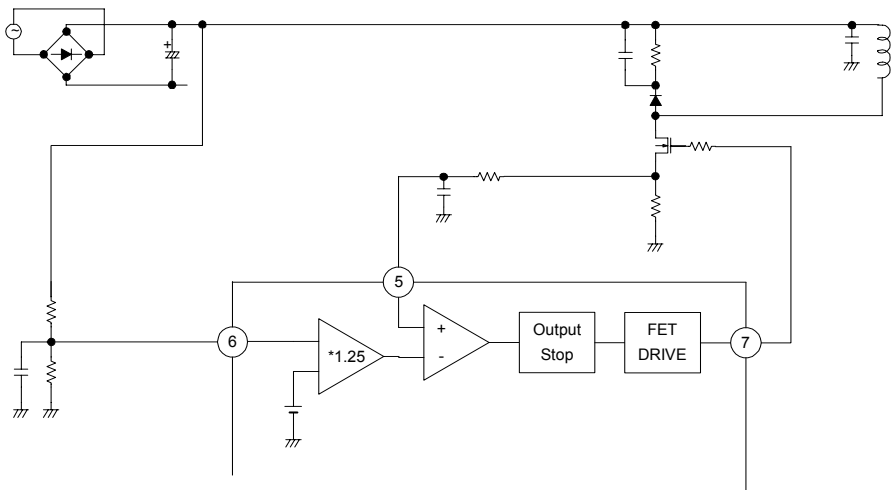

Figure 2. Block Diagram of OPP and OCL Portion

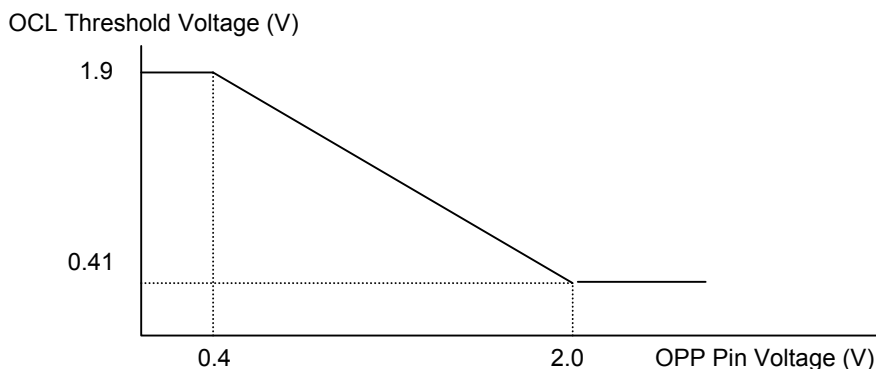

Figure 3. Relationship between OPP Pin Voltage and OCL Threshold

● OCL (Over Current Limiter)

The OCL circuit detects the source current as a voltage signal by feeding resistance to the MOSFET source. When this voltage signal exceeds the threshold voltage, the OCL function protects the circuit by lowering the pulse output signal.

As explained in the OPP circuit block, the OCL threshold can be varied from 0.41 V to 1.9 V using the OPP pin voltage. If the OPP pin is left open (with only a ground condenser), the OCL threshold voltage is fixed to 0.41 V.

● OVP (Over Voltage Protection)

The IC is equipped with a Vcc overvoltage protector to prevent IC damage should Vcc voltage greater than the maximum allowed voltage flow into pin 8. If the Vcc's voltage exceeds 25 V (typ.), all circuits except for the UVLO circuit are halted.

● The Oscillator

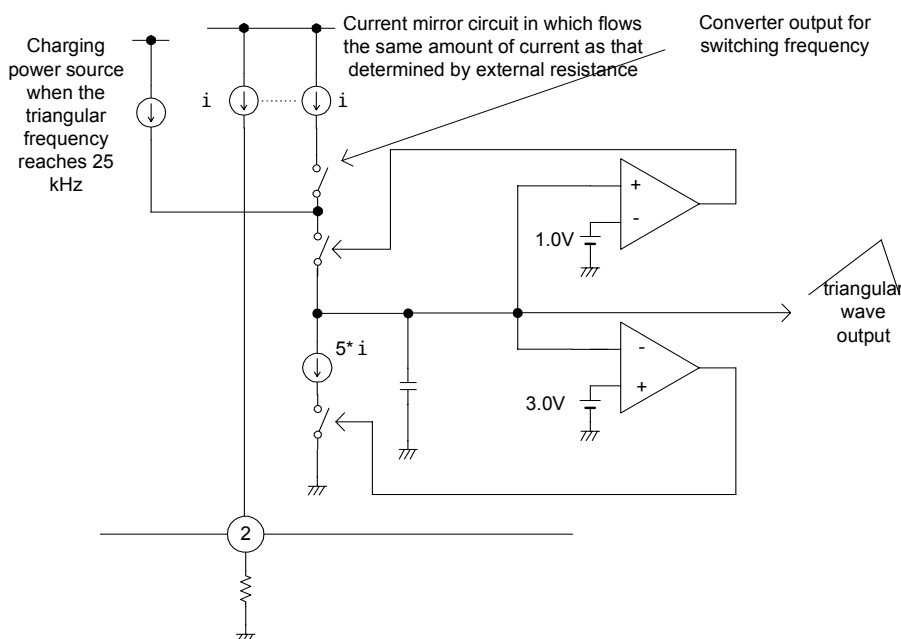

The oscillator is the device that generates the triangular waves for obtaining drive pulses to drive the MOSFET. The output pulse duty is determined by thresholding the triangular wave voltage. The frequency is determined by the external resistance fed to pin 2 (FREQ. SET).

Triangular waves are formed by charging and discharging the condenser inside the IC. The oscillation voltage is between 3 and 1 V. The charge/discharge ratio is fixed at 5:1. During discharge, the voltage is output until the number of drive pulses is lowered. The charge/discharge is set using the external resistance. It is possible to set the frequency at will from approximately 25 kHz to 150 kHz. The maximum duty is fixed to about 68% (typ.) regardless of the frequency used.

In addition, it is possible to reduce the switching loss (as with light loads during standby mode) since there is a control that switches the frequency of the triangular wave to about 25 kHz when pin-4's (FB IN) voltage exceeds the limit set by pin 3 (STB SET).

- **Oscillation Frequency**

The oscillation frequency and external resistance are extrapolated using the following formula:

$$f \text{ (kHz)} = 2.08 \times 10^6 / (0.5 + R) + 25.2$$

Overlaid frequency due to external resistance Frequency determined internally by the IC

Based on the above...

...if 82 kΩ is input between pin 2 and GND, it will be about 50 kHz.

...if 20 kΩ is input between pin 2 and GND, it will be about 100 kHz

and

...if 13 kΩ is input between pin 2 and GND, it will be about 150 kHz

The IC is compatible to a drive frequency setting range of 25 kHz to 150 kHz.

- **PWM Converter**

The PWM converter determines the drive pulse duty by slicing the voltage input to the FB IN pin during the rising edge of the triangular waves formed internally by the IC.

At start up, during the times it takes to charge the internal soft start condenser to 3 V (about 80 μs), a soft start is triggered and output pulses gradually spread.

- **Output**

The output is a BIP push-pull construction that uses an NPN transistor. It is possible to directly drive a MOSFET of around 2SK1359 (ID = 5A, Ciss = 700 pF, Rds (on) = 3.0 Ω). The PULSE OUT pin's FET gate drive capacity has a maximum sink about 400 mA and a maximum source of about 400 mA.

It is possible to put the MOSFET in an OFF state since the OCL circuit protection function enables the PULSE OUT pin's output to go low.

● **UVLO** (Under Voltage Lock Out)

The IC is equipped with an UVLO circuit to prevent IC malfunction should Vcc voltage drop.

When the IC starts up, the Vcc voltage raises up from GND level to 11.5 V(typ.), at which point the UVLO circuit is released and the IC begins operating. The startup current is 60 μ A (typ.), so the startup resistance can be configured quite high to reduce the about of loss due to startup resistance.

If the Vcc voltage reaches 9 V (typ.), all circuits except for the UVLO circuit are halted. (Please use precaution as the UVLO voltage has a temperature drift.)

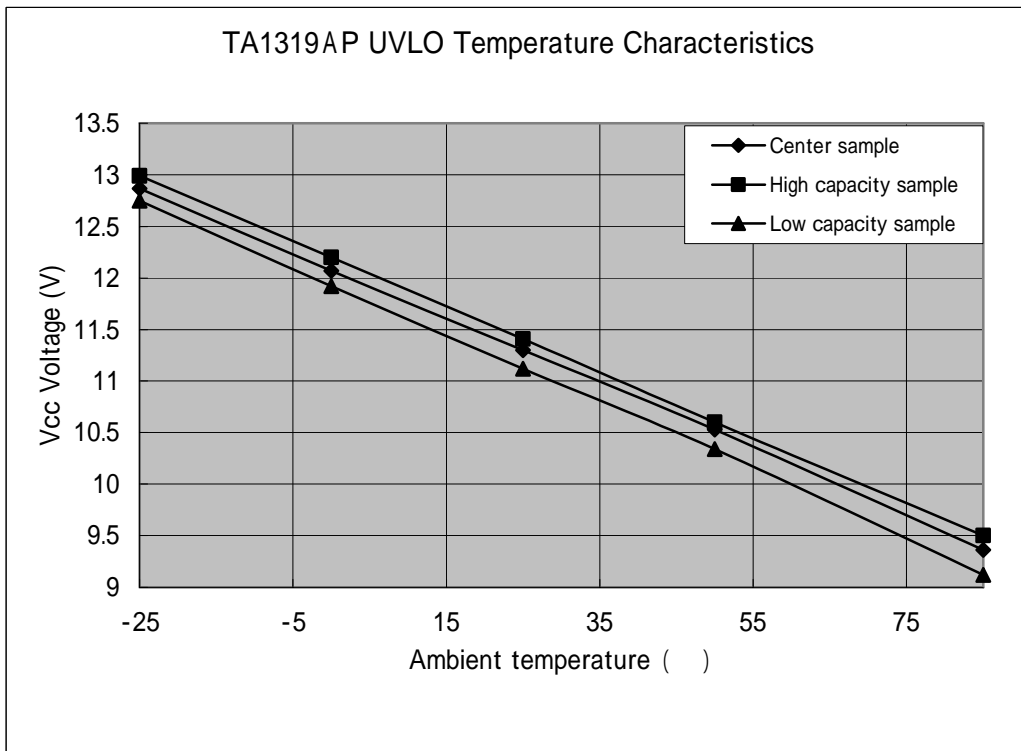
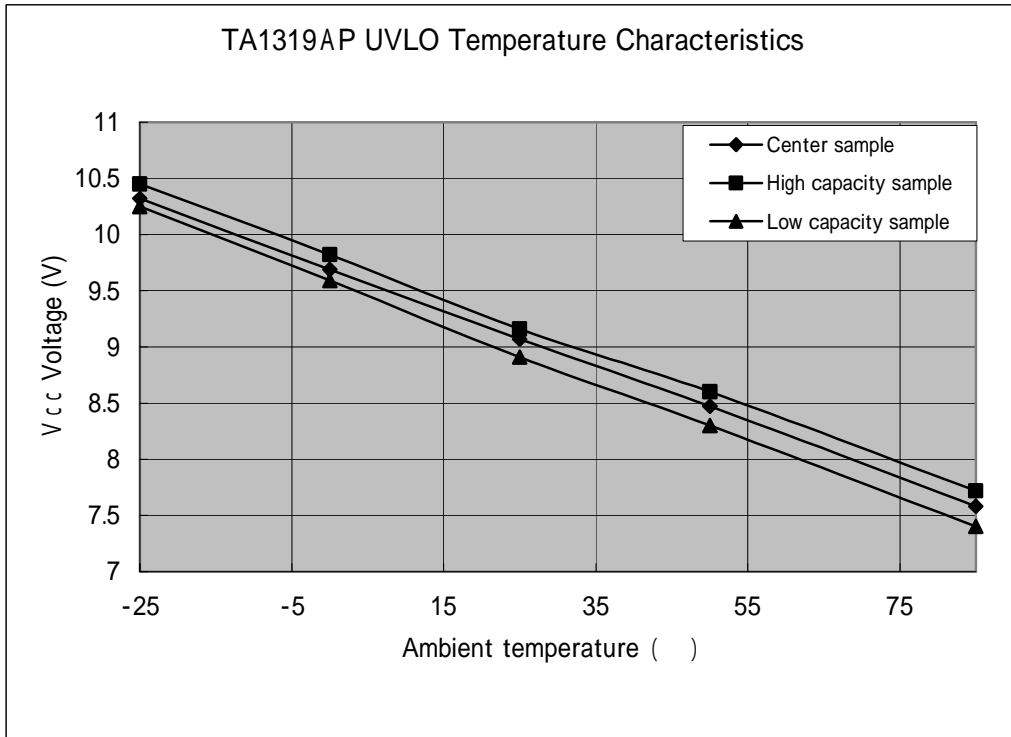

Handling Precautions

If this device is exposed to magnetic fields, impedance changes and an increase in leak current will result due to polarization of the plastic material and IC chip. We have heard of malfunctions due to installing LSIs in the vicinity of television deflection yokes. In such cases, it is necessary to change the mounting location and use electromagnetic and magnetic field shields. Magnetic shields are especially necessary in revolving magnetic fields environments, since EMF (electromagnetic force) will be generated.

PIN CONNECTION (TOP VIEW)

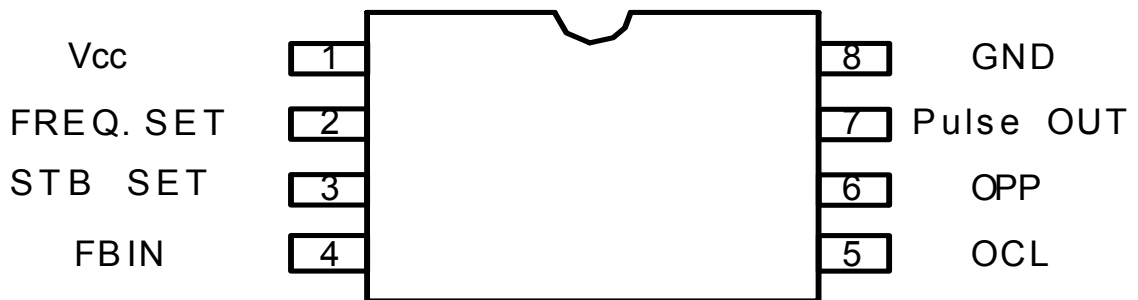

pin-2 (FREQ. SET)

Please use a product that has $\pm 2\%$ accuracy for pin-3's (STB SET) external resistance.

Pin Functionality

No.	Name	Function	Interface
1	Vcc	<p>The power supply pin for this IC.</p> <p>This IC is equipped with UVLO (Under Voltage Lock Out). When the Vcc voltage rises above 11.5 V (typ.) the circuit starts operating, and when it drops below 9 V (typ.), it stops. (Please use caution as UVLO voltage has temperature fluctuation.)</p> <p>The power voltage flow for Vcc is 13 to 22 V.</p> <p>The IC startup current is 60 μA (typ.).</p> <p>If the Vcc pin voltage goes above its maximum rated voltage of 25 V (typ.), the latch up protector will actuate and stop all operations other than the UVLO circuit.</p>	
2	FREQ. SET	<p>The pin used to set the oscillation frequency for the internal oscillator circuit. Connects to and supplies resistance (R_{ext}) to GND. As that value changes, this pin controls the oscillation frequency.</p> <p>The relationship between the frequency and external resistance is as follows:</p> <p>ExtR = when 82 kΩ, about 50 kHz when 20 kΩ, about 100 kHz when 13 kΩ, about 150 kHz</p> <p>The drive frequency setting range is 25 kHz to 150 kHz.</p>	
3	STB SET	<p>As the load lightens, the FB IN voltage increases. This pin uses that phenomenon to switch to low frequency continuous mode when the voltage goes higher than the set threshold.</p> <p>The mode transition voltage setting can be adjusted by the external resistance applied to the STB SET pin.</p>	

Pin Functionality

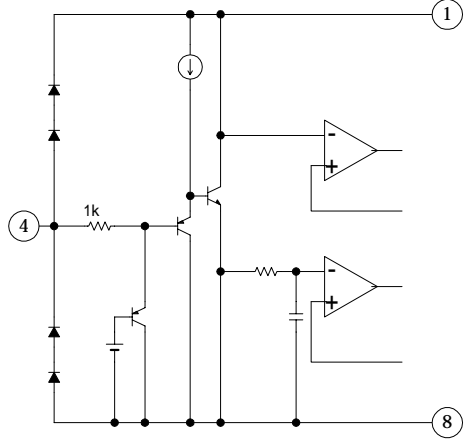
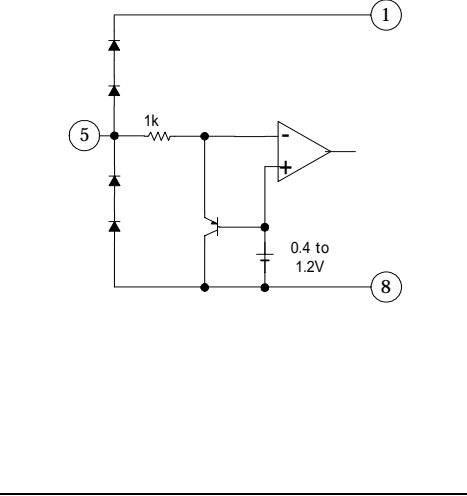
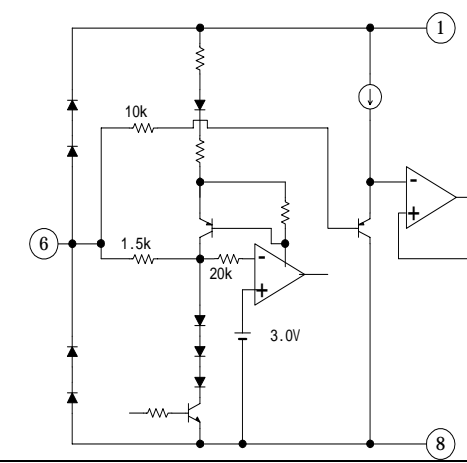
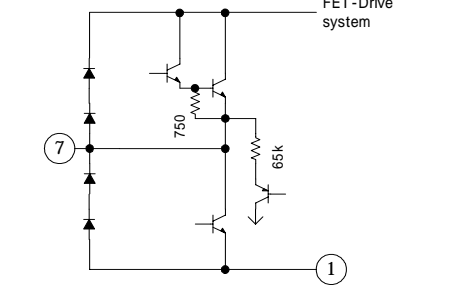
No.	Name	Function	Interface
4	FB IN	<p>Drive pulse duty is determined by slicing the voltage input to the FB IN pin during the rising edge of the triangular waves formed internally by the IC.</p> <p>If the FB IN pin's voltage rises above the threshold determined by pin-3's (STB SET) external resistance, then it is forced into low frequency PWM mode and goes into standby mode.</p>	
5	OCL	<p>Pin used to make detection for MOSFET overcurrent protection used for PWM output. The detection resistance's detection voltage input to the power MOSFET's source is input to pin 5 via the external LPF. The detection voltage changes by the OPP pin voltage and when the OPP pin is open, it will be set to 0.41 V (typ.).</p> <p>When voltage exceeding the threshold is input, the PWM pulse output is lowered and kept as low as the PWM (-) output pulse's starting phase (in real time).</p>	
6	OPP	<p>The OPP causes the OCL comparator's reference voltage to vary with the DC voltage input to the OPP pin and actuates the OCL in regard to power that exceeds the set current level.</p> <p>The DC voltage input to the OPP pin inputs the input AC voltage that has undergone the resistance split, and works to lower the lower the OCL threshold as pin-6's voltage goes higher. Therefore, the higher the AC voltage, the lower the OCL threshold.</p> <p>If the OPP pin is open, the OCL threshold is fixed to 0.41 V (typ.).</p>	
7	Pulse Out	<p>The pulse output pin used to drive the power MOSFET.</p>	
8	GND	<p>The IC's ground pin.</p>	

Maximum Rating (Ta = 25°C)

Item	Symbol	Rating	Unit	
Power supply voltage	Vccmax	24	V	
Maximum excitation voltage of each pin	Vinmax	Vcc+0.3	V	
Minimum excitation voltage of each pin	Vinmin	GND-0.3	V	
Power drop-1 (*1-1)	TA1319AF	PDmax	430	mW
Power drop-2 (*1-2)			538	mW
Power drop-3 (*2)			806	mW
Operating temperature (*3)	Topr	-25 to 85	°C	
Storage temperature	Tstg	-55 to 150	°C	

(*1-1) 3.44 mW is lost for each degree Celsius the temperature rises after above 25°C.

(*1-2) Mounted on board (glass epoxy board, 50×50×1.6 mm, copper foil area 30%)

The IC itself loses 4.31 mW for each degree Celsius the temperature rises after above 25°C.

(*2) 6.45 mW is lost for each degree Celsius the temperature rises after above 25°C.

(*3) The temperature range in which the IC is designed to run without problem related to temperature.

The heating value has increased (in regard to the thermal resistance of the TA1319AF package). When designing your product, be sure to make sufficient consideration for ventilation (increasing the board's pattern area, inserting ventilation holes in the shield case, et al.)

Power Consumption

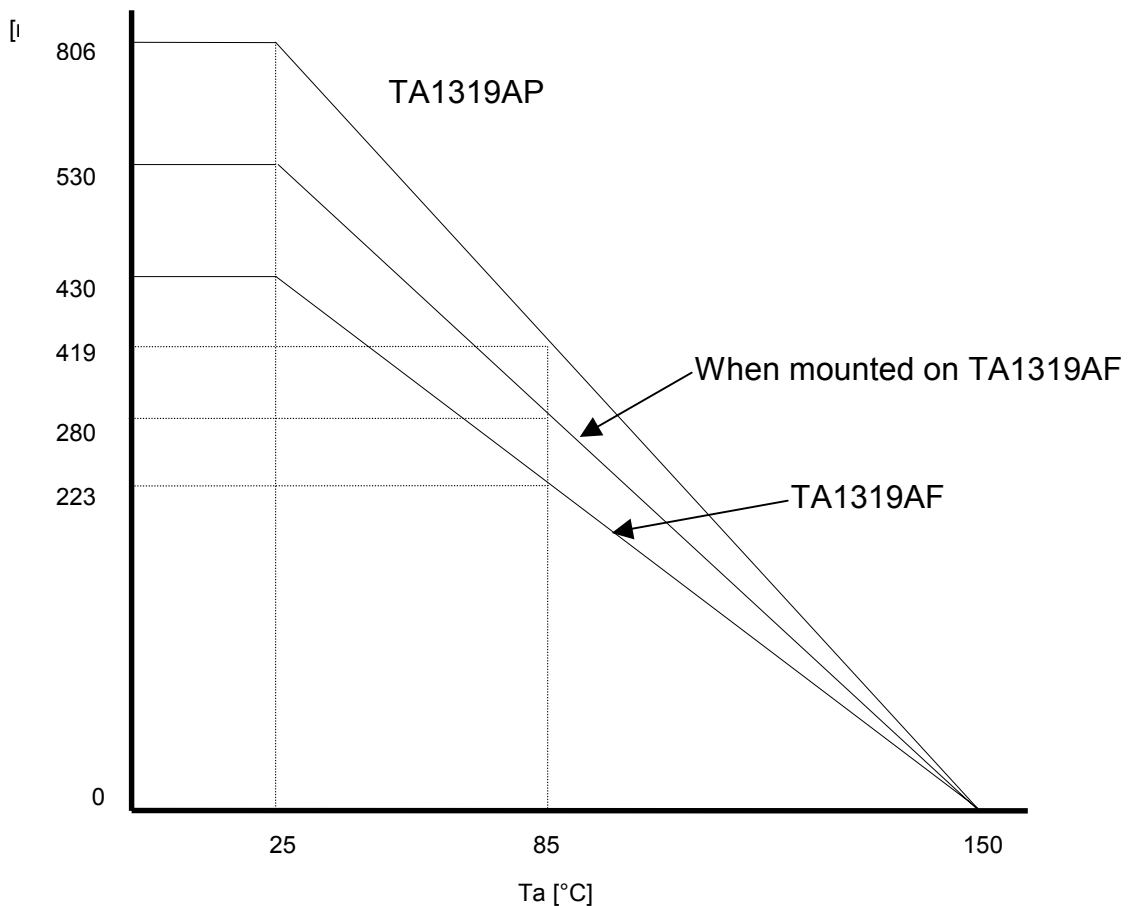

Figure 4. Power Consumption Temperature Reduction

Recommended Operating Conditions (Ta = 25°C)

Item	Pin No.	Minimum	Standard	Maximum	Unit
Power supply voltage (Note 3)	Pin 1	9.5	-	24.0	V

(Note 3) The power supply voltage range for which the IC is designed for stable operation.

If there isn't any particular specification made in regard to electronic characteristics, then Vcc = 20 V and Ta = 25°C

(See Figure 4 Direct Current Pin Voltage Measurement Circuit in regard to the measuring method)

Item	Pin No.	Symbol	Minimum	Standard	Maximum	Unit
Current consumption	Pin 1	I1On	2.0	3.0	4.0	mA
(The above is for when pin 7 (Pulse OUT) is open.) SW1 = a, SW2 = a						
Current consumption	Pin 1	I1LoadOn	3.0	4.0	5.0	mA
(The above is for when pin 7 (Pulse OUT) is connected to a load of 820 pF (The equivalent of 2SK1359Ciss = 700 pF)) SW1 = a, SW2 = b						
Current consumption	Pin 1	I1LoadOff	1.0	2.5	4.0	mA
(The above is for when Vcc's voltage drops to 20 V after pin 7 is connected to a load of 820 pF, DC = 25 V is fed to pin 1 (Vcc) and OVP latch protect has been actuated.) SW1 = a, SW2 = b						
Pin 4 mode transition threshold voltage	Pin-3's external resistance R = 1.5 kΩ (SW1 = a)	V3thL 5.6k	2.25	2.3	2.35	V
	Pin-3's external resistance R = 27 kΩ (SW1 = b)	V3thL 68k	2.64	2.69	2.74	

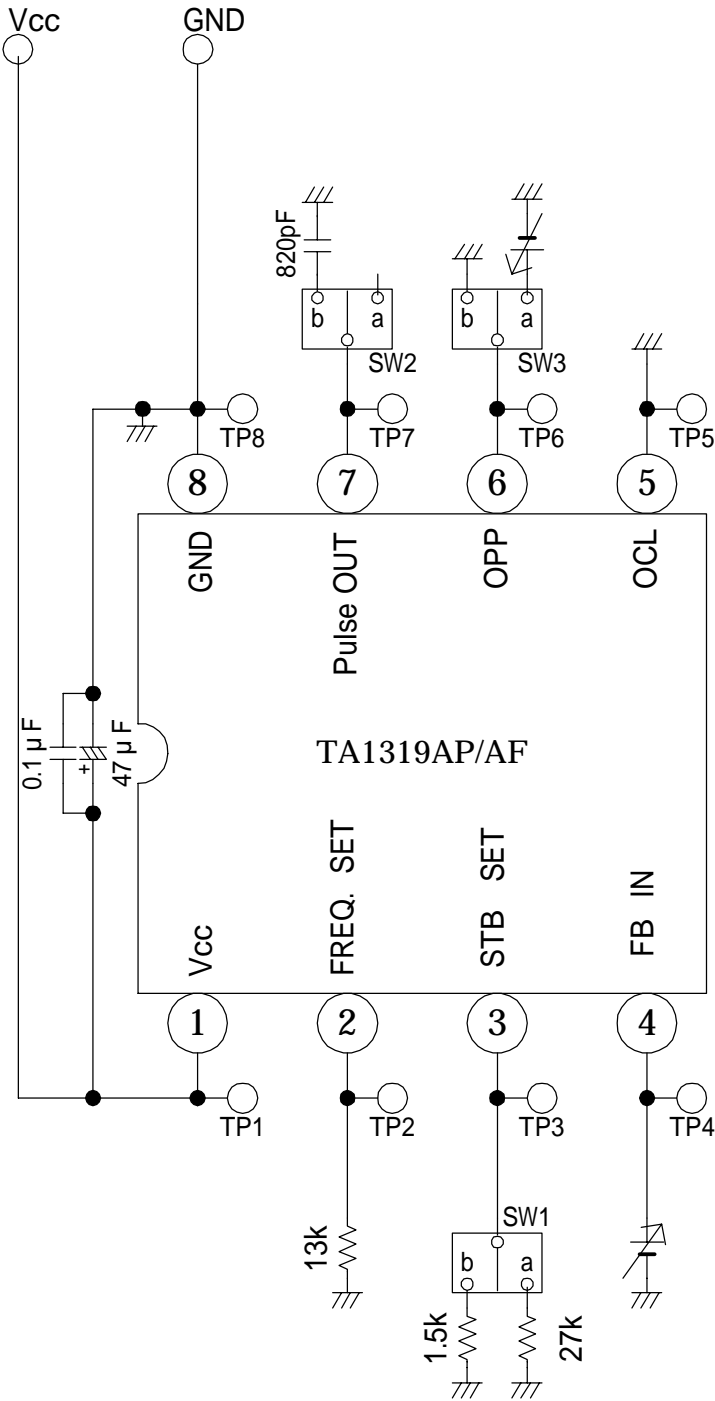

Pin-2 (FREQ. SET)
 Please use a product that has $\pm 2\%$ accuracy
 for pin-3's (STB SET) external resistance.

Figure 5. Direct Current Pin Voltage Measurement Circuit

AC Characteristics (Unless otherwise specified, Vcc = 20 V, Ta = 25°C; see Figure 5 AC Characteristics Measuring Circuit)

Item	Symbol	Measuring Conditions	Min.	Std.	Max.	Unit
UVLO operating voltage	VUL	SW1 = a, SW2 = b, SW3 = a, SW4 = a, SW5 = a, SW6 = b Connect GND to pin 4 (FB IN).	8.5	9.0	9.5	V
	VUH	Lower Vcc's voltage while pin 7 (Pulse OUT) is outputting pulses, and measure the power source voltage (VUL) when pin 7 starts running out of pulses. Raise the power voltage when pin 7 runs out of output pulses and measure the power source voltage (VUH) when pin 7 starts outputting pulses.	11.0	11.5	12.0	
Startup current	Istrt	SW1 = a, SW2 = b, SW3 = a, SW4 = a, SW5 = a, SW6 = b Connect to GND to pin 4 (FB IN). Measure Vcc's influx current (Istrt) when Vcc goes to 9 V from a state of pin 7 outputting no voltage (Vcc = 5 V or less).	45	60	90	μA
Triangular oscillation frequency	fOSC1	SW1 = b, SW2 = b, SW3 = a, SW4 = a, SW5 = a, SW6 = b Connect to GND to pin 4 (FB IN), and cause pin 7 to output pulses.	20	28.0	35	kHz
	fOSC2	Measure the pulse cycle and seek out the frequency (Fosc).	40.0	50.0	60.0	kHz
	fOSC3	fOSC1: The pulse frequency when pin-4's voltage was fixed to 2.8 V when pin-2's external resistance was 82 kΩ. fOSC2: The pulse frequency when pin-4's voltage was fixed to 0 V when pin-2's external resistance was 82 kΩ. fOSC3: The pulse frequency when pin-4's voltage was fixed to 0 V when pin-2's external resistance was 13 kΩ.	120.0	150.0	180.0	kHz
Output pulse leading edge time (Reference data)	TRPF	SW1 = a, SW2 = b, SW3 = a, SW4 = a, SW5 = a, SW6 = b In the above state, seek out the leading edge time difference (TRPF) when the output pulse's amplitude is raised from a 10% level to a 90% level.	70	100	130	ns
Output pulse training edge time (Reference data)	TSPF	SW1 = a, SW2 = b, SW3 = a, SW4 = a, SW5 = a, SW6 = b In the above state, seek out the trailing edge time difference (TSPF) when the output pulse's amplitude is lowered from a 90% level to a 10% level.	70	100	130	ns

AC Characteristics (Unless otherwise specified, $V_{cc} = 20\text{ V}$, $T_a = 25^\circ\text{C}$; see Figure 5 AC Characteristics Measuring Circuit)

Item	Symbol	Measuring Conditions	Min.	Std.	Max.	Unit
Output pulse maximum voltage	VOMAX 1	SW1 = a, SW2 = b, SW3 = a, SW4 = a, SW5 = a, SW6 = a In the above state, measure the output pulse's maximum voltage (VOMAX).	11	12	13	V
	VOMAX 2	VOMAX1: $V_{cc} = 20\text{ V}$ VOMAX2: $V_{cc} = 10\text{ V}$	6	7	9	
Output pulse minimum voltage	VOMIN	SW1 = a, SW2 = b, SW3 = a, SW4 = a, SW5 = a, SW6 = a In the above state, measure the output pulse's minimum voltage (VOMIN).	0	0.1	0.5	V
Output current (SORCE, SINK) (Reference data)	IOC	SW1 = a, SW2 = b, SW3 = a, SW4 = a, SW5 = a, SW6 = b Use a current probe to measure the current (IOC) flowing to pin 7.	310	400	550	mA
Triangular wave threshold maximum voltage	TrVth Max	SW1 = a, SW2 = b, SW3 = c, SW4 = a, SW5 = a, SW6 = b Apply external voltage to pin 4 (default = 2.0 V) and then check for output voltage at pin 7. Raise the external voltage and then measure pin-4's voltage when	2.75	2.8	2.85	V
Triangular wave threshold minimum voltage	TrVth Min	the output pulses run out. (TrVthMax) From the point that the pulses run out, lower the external voltage and then when the output pulses reach their maximum duty, measure pin-4's voltage. (TrVthMin)	0.8	1.0	1.2	
Output pulse maximum duty	Vomax	SW1 = a, SW2 = b, SW3 = c, SW4 = a, SW5 = a, SW6 = b Apply external voltage to pin 4 (default = 2.0 V) and then make sure that output pulses at pin 7.	60	68	70	%
Output pulse minimum duty	Vomin	Raise pin-4's voltage and then measure the minimum duty as the pulse's duty grows smaller. Lower pin-4's voltage and then measure the maximum duty as the pulse's duty grows larger.	0	-	-	%

AC Characteristics (Unless otherwise specified, $V_{cc} = 20\text{ V}$, $T_a = 25^\circ\text{C}$; see Figure 5 AC Characteristics Measuring Circuit)

Item	Symbol	Measuring Conditions	Min.	Std.	Max.	Unit
Soft start time	Tstart	SW1 = a, SW2 = b, SW3 = a, SW4 = a, SW5 = a, SW6 = b Measure the time it takes for V_{cc} 's voltage to clear 8 V, UVLO gets released, and the pulse's duty goes gradually from 0 to its maximum.	70	80	100	μsec
OCL pin (#5) PROTECT operation voltage	V5pt1	SW1 = a, SW2 = b, SW3 = a, SW4 = a, SW5 = a, SW6 = b	0.4	0.41	0.42	V
	V5pt2	Apply external voltage to pin 5 (OCL) and then measure pin-5's voltage (V5pt) as the external voltage increases and the output pulses stop run out.	1.8	1.9	2.0	
	V5pt3	V5pt1: When pin 6 is fixed to DC = 2.6 V V5pt2: When pin 6 is fixed to DC = 0 V V5pt3: When pin 6 is open	0.4	0.41	0.42	
Vcc pin (#1) OVLO operation voltage	Vovlo	SW1 = a, SW2 = b, SW3 = a, SW4 = a, SW5 = a, SW6 = b Raise the power voltage of pin 1 (V_{cc}) and then measure pin-1's voltage (V1OVLO) when the output pulses stop run out (latching has started).	24.0	24.5	25.0	V
Internal reference voltage	Vstd	SW1 = a, SW2 = b, SW3 = a, SW4 = a, SW5 = a, SW6 = b Measure pin-3's (STB SW) DC voltage.	2.90	3.00	3.10	V
FB IN pin (#4) influx current	I FBIN	SW1 = b, SW2 = a, SW3 = a, SW4 = a, SW5 = b Connect external voltage (3.0 V) to pin 4 (FB IN) and measure the influx current to the pin.	0.2	0.4	0.6	μA

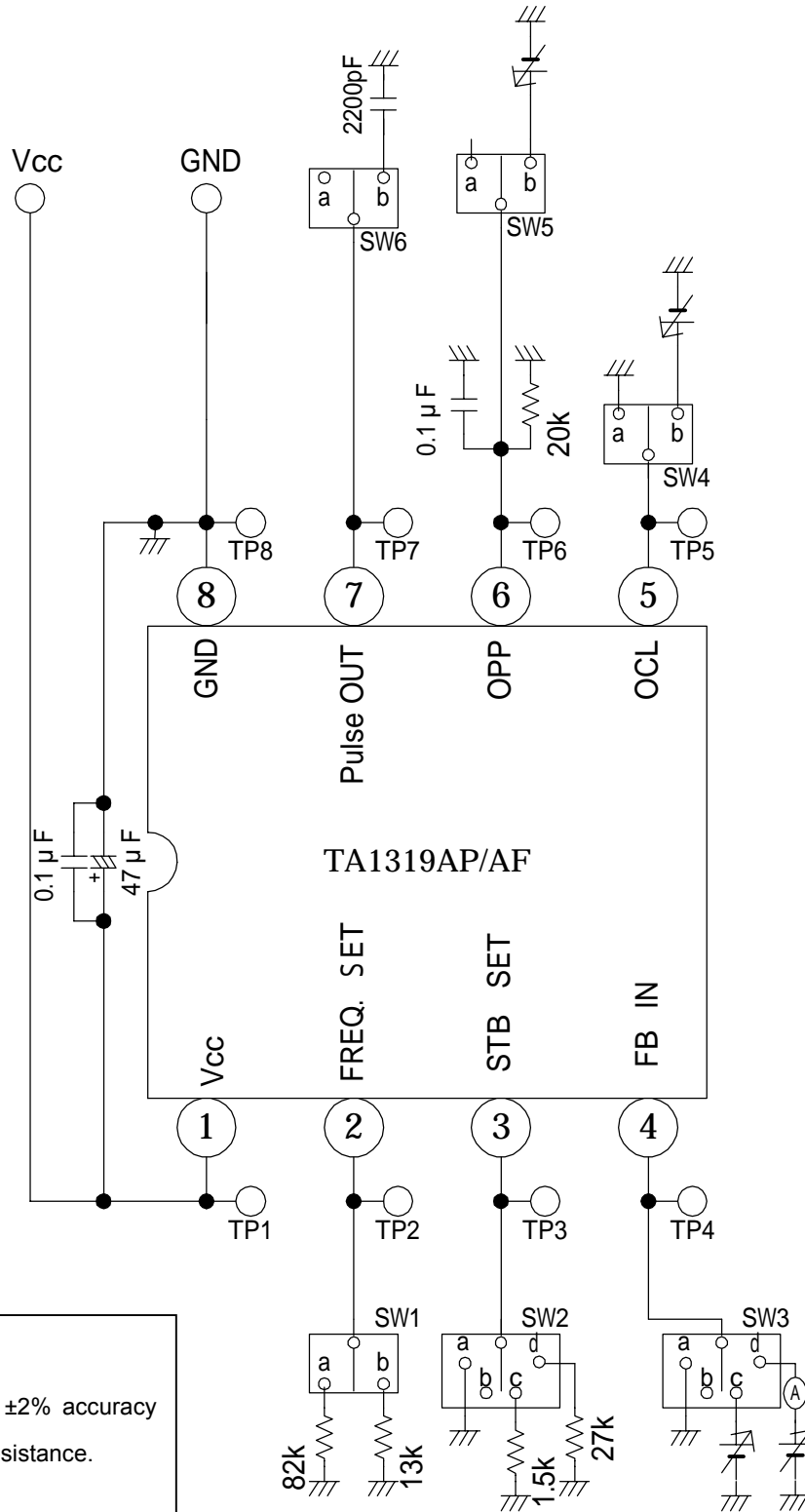

Pin-2 (FREQ. SET)
 Please use a product that has $\pm 2\%$ accuracy
 for pin-3's (STB SET) external resistance.

Figure 6. AC Characteristics Measuring Circuit

Power Supply Unit Configuration (Reference)

• Introduction

The Power Supply Unit is designed to be AC widerange compatible (85 to 264 VAC) and is equipped with standby mode (low frequency operation transition function) for improving the power efficiency during low load situations like standby.

The power consumption when AV = 100 V and there is no load is approximately 0.59 W.

• There are two ways to make the transition to standby mode:

Switching Using the Control Signal

(Method in which a control signal from the microcontroller is utilized to make the switch to standby mode.)

Applied Circuit Example.....P.21

Power Efficiency.....P.22

(Check for differences in efficiency due to drive frequency and differences in efficiency due to AC voltage levels.)

Automatic Switching

Since the FB IN pin's voltage grows when the load gets light, the IC controls are configured to take advantage of this phenomenon by switching to standby mode when the voltage rises above the set voltage of the STB pin.

Applied Circuit Example.....P.23

Power Efficiency.....P.24

• Reference Material

Widerange Transformer Specifications.....P.25

100 VAC Dedicated Transformer Efficiency ComparisonsP.26

(Power consumption during unloaded conditions after switching to a 100 VAC dedicated transformer comes to about 0.4 W. This is believed to be due to the increased of 5 turns in the primary side transformer).

100 VAC Dedicated Transformer Specifications.....P.27

During the evaluation we will vary the standby power with the transformers we use, using the MOSFET's ON resistance value and altering the secondary load state. Please keep this in mind during your observations.

TA1319AP DEMO POWER SUPPLY CIRCUIT DRAWING
(MODE SWITCH : EXTERNAL SIGNAL)

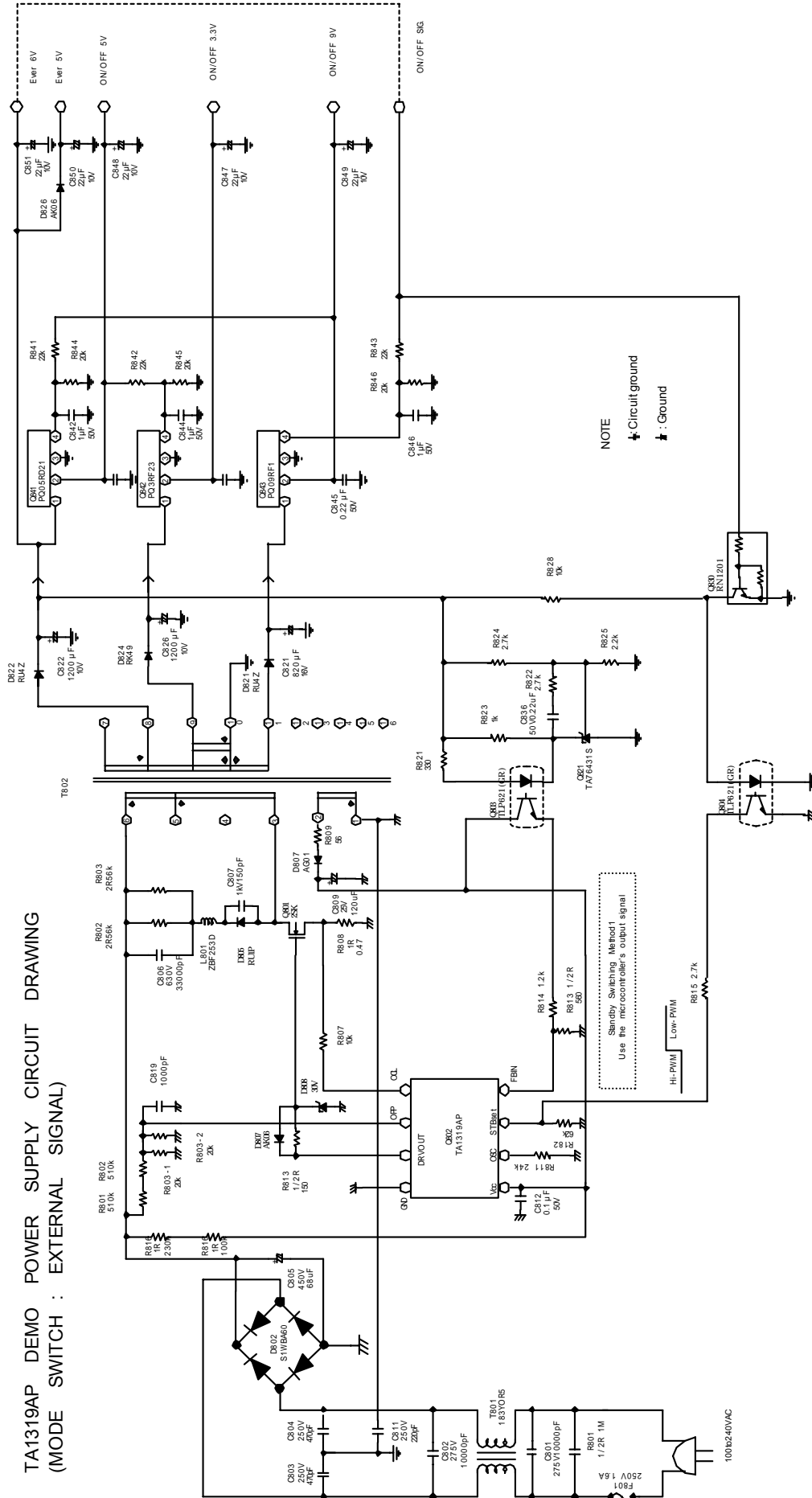

NOTE
 ↕ : Circuit ground
 ⚡ : Ground

Standby Switching Method 1
 Use the microcontroller's output signal!

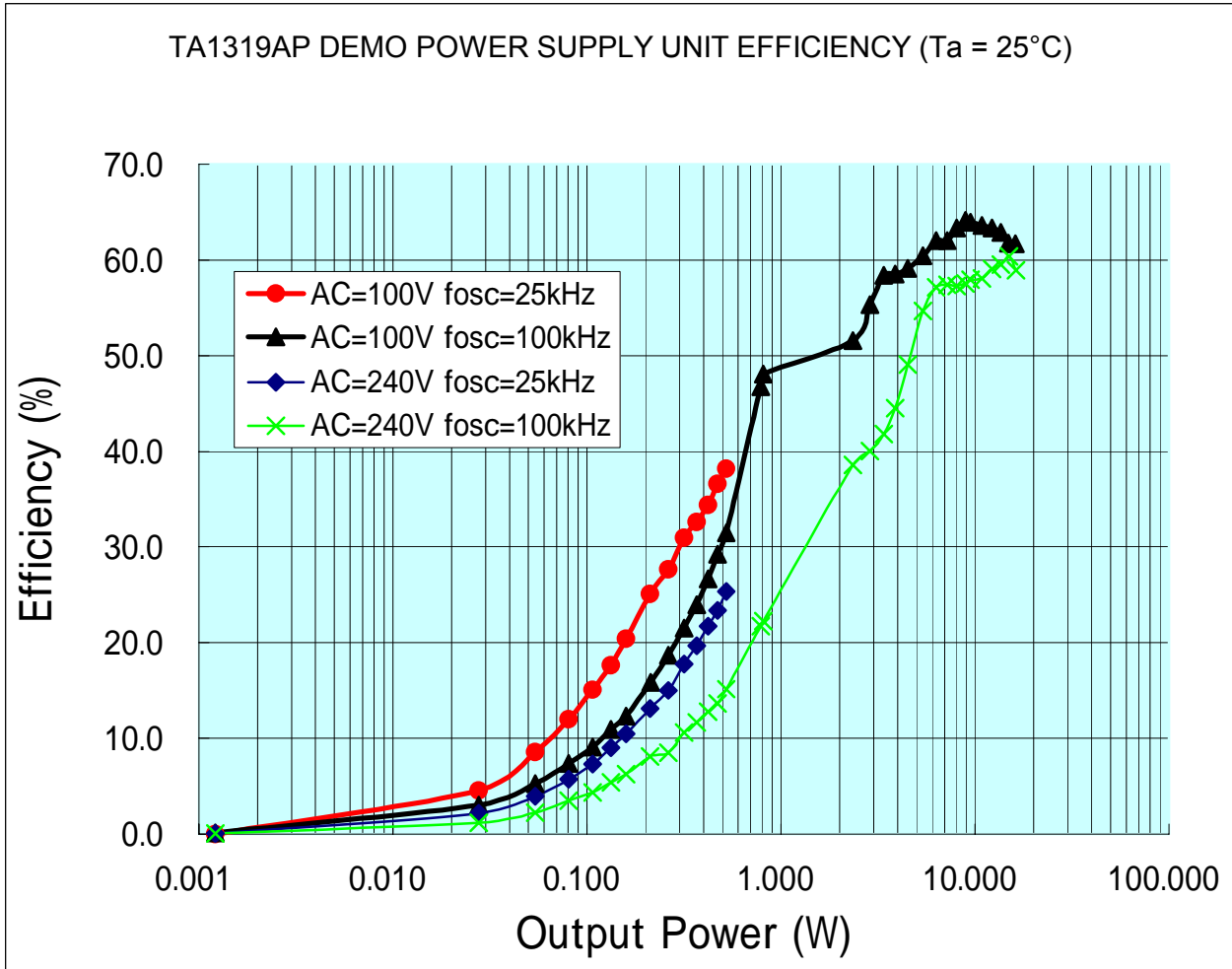

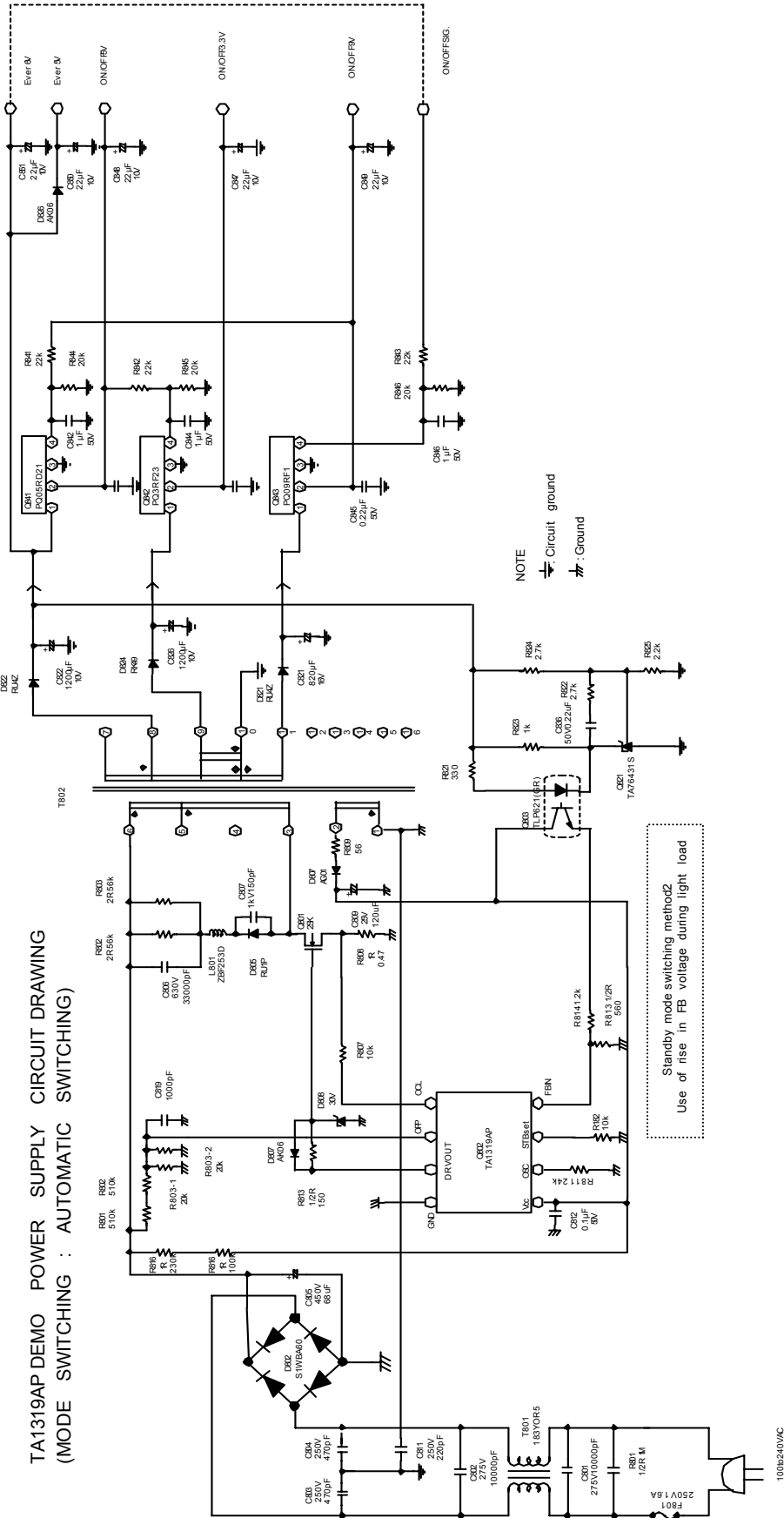

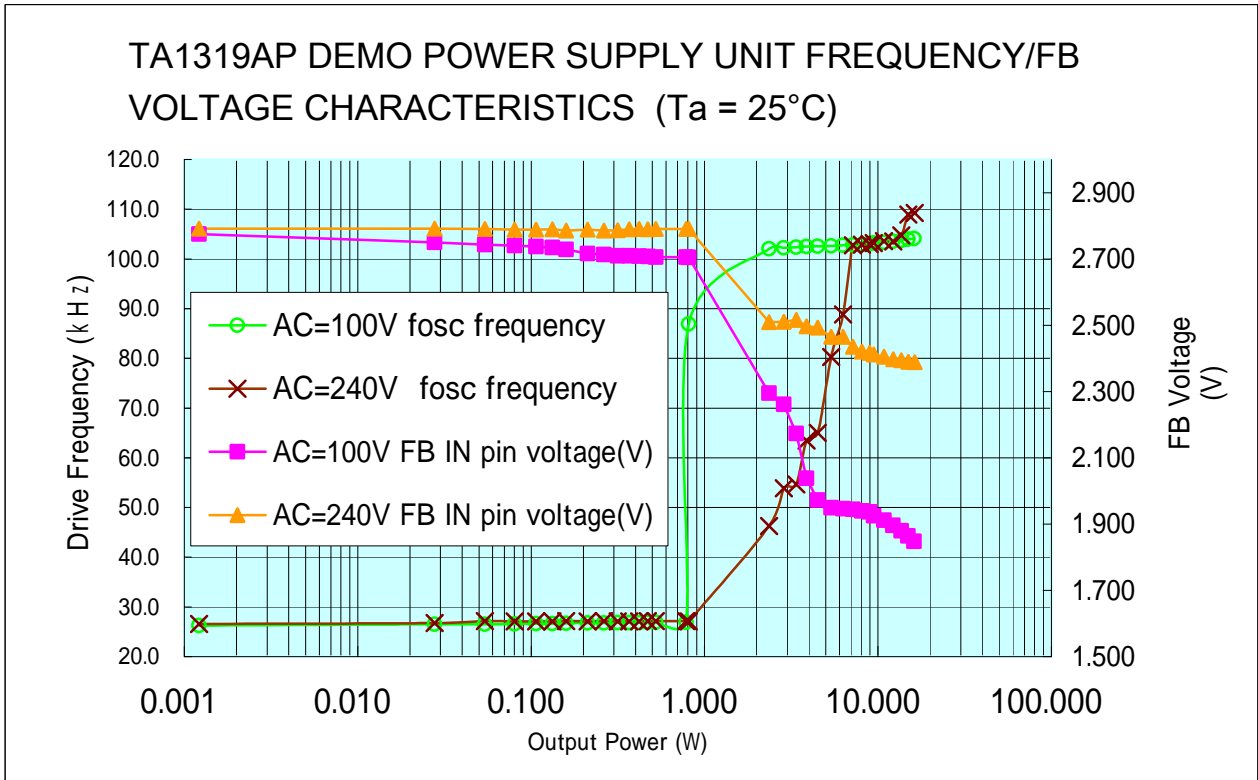
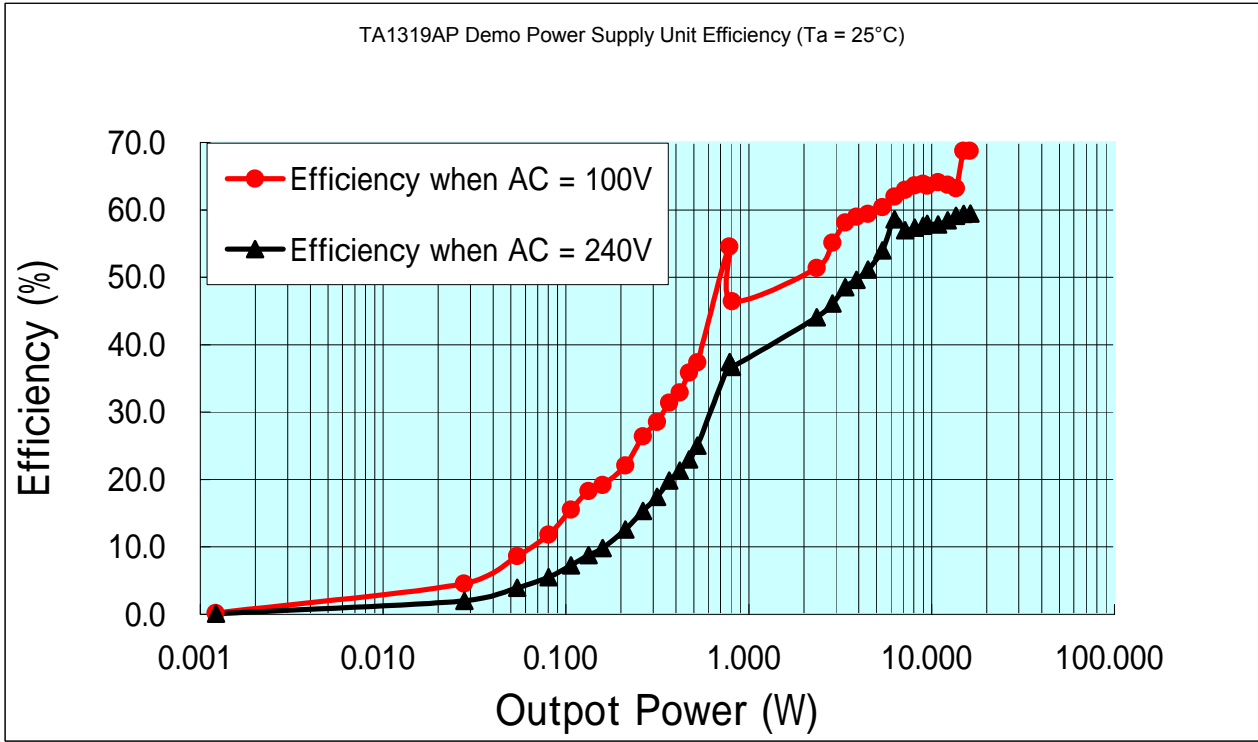

• AC Widerange Power Supply Transformer Specifications

1. Input Voltage Range: 85 to 264 VAC
2. Output Voltage: Pin 8 + 6 V 1.4 A
Pin 9 + 4 V 1.6 A
Pin 11 + 9 V 0.35 A (1.35 A peak)
3. Oscillation Frequency: 25 to 100 kHz
4. Inductance L_p : 1.2 mH (typ.)
5. Wiring
 - NP1: 33 t 0.2 mm
 - NP2: 32 t 0.2 mm
 - ND: 15 t 0.2 mm
 - N6: 6 t 0.4 mm
 - N4: 5 t 0.4 mm
6. Bobbin CPJ-8600
7. Ferrite Core EED30/20
8. Camp 4 mm
9. Connection diagram

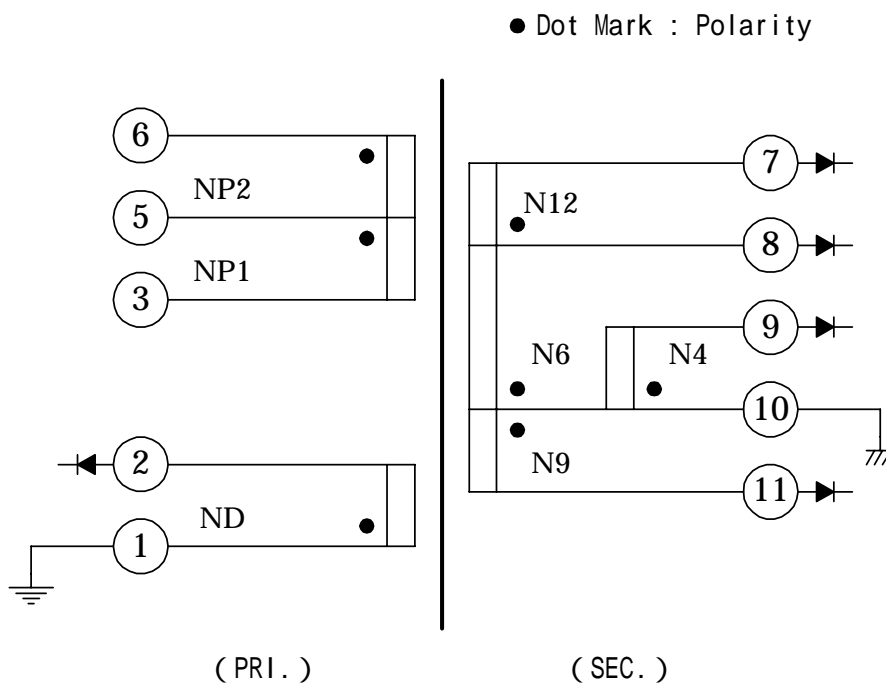

100 VAC Dedicated Transformer Efficiency Comparisons

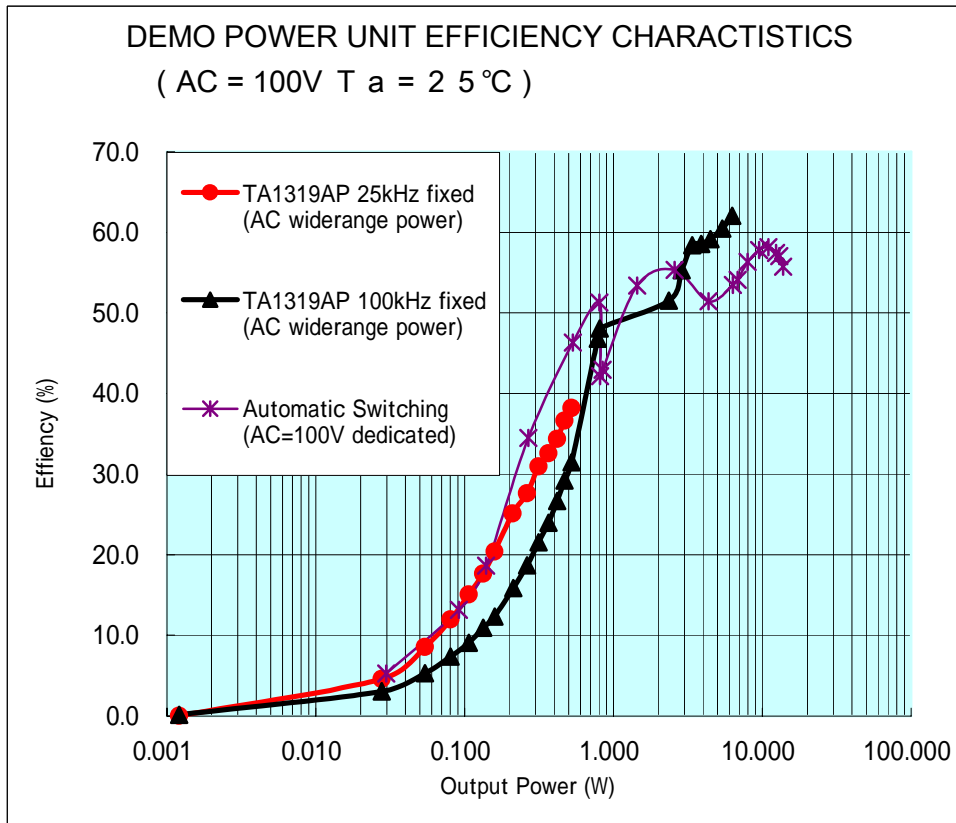

• 100 VAC Dedicated Transformer Specifications

1. Input Voltage Range: 85 to 120 VAC
2. Output Voltage:
 - Pin 7 + 9 V 0.35 A
 - Pin 8 + 6 V 1.2 A
 - Pin 9 GND
 - Pin 13 + 5 V 0.15 A
 - Pin 14 GND
3. Oscillation Frequency: 25 to 100 kHz
4. Inductance L_p 1.15 mH (typ.)
5. Wiring
 - NP1: 30 t 0.2 mm
 - NP2: 30 t 0.2 mm
 - ND: 15 t 0.2 mm
 - N6: 6 t 0.4 mm
 - N9: 9 t 0.4 mm
 - N5: 4 t 0.2 mm
6. Bobbin PM9820
7. Ferrite Core EED28/20
8. Gap 4 mm
9. Connection diagram

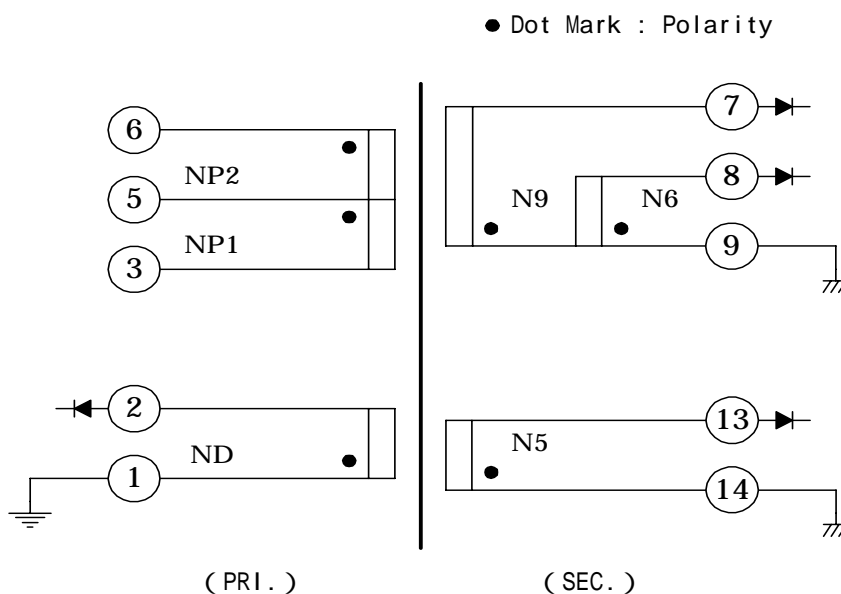

Package

DIP8-P-300-2.54A

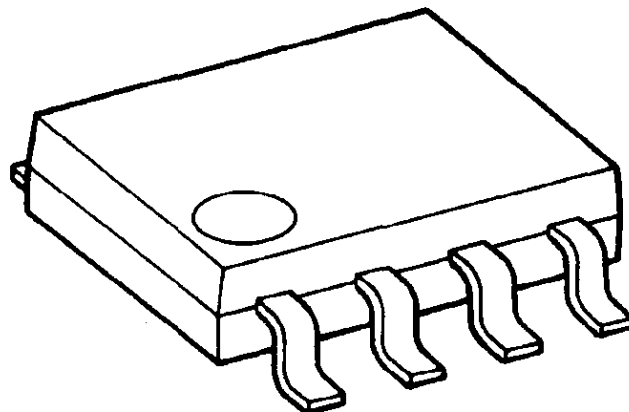
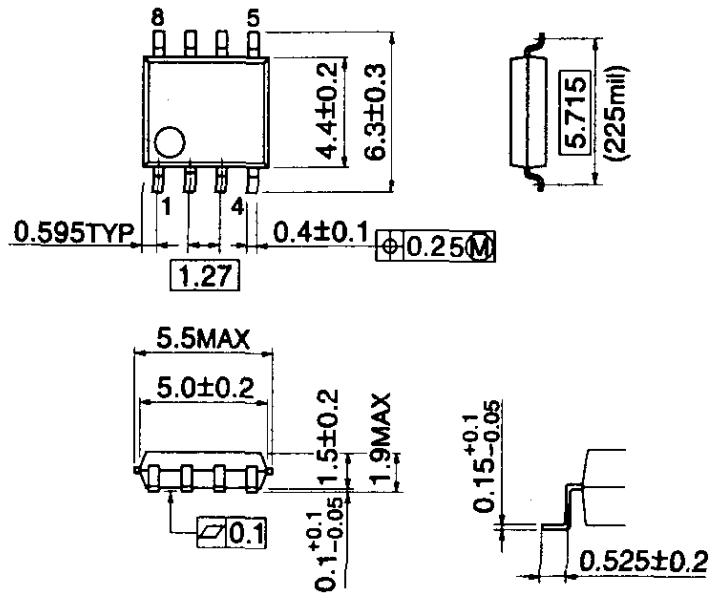

SOP8-P-225-1.27

