

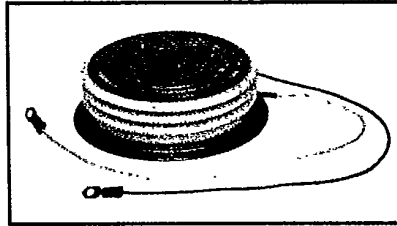

TA20

Powerex, Inc. Hillis Street, Youngwood, Pennsylvania 15697 (412) 925-7272
 Powerex Europe, S.A., 428 Ave. G. Durand, BP107, 72003 LeMans, France (43) 72.75.15

Phase Control SCR
 1600-1800 Amperes Avg
 100-2200 Volts

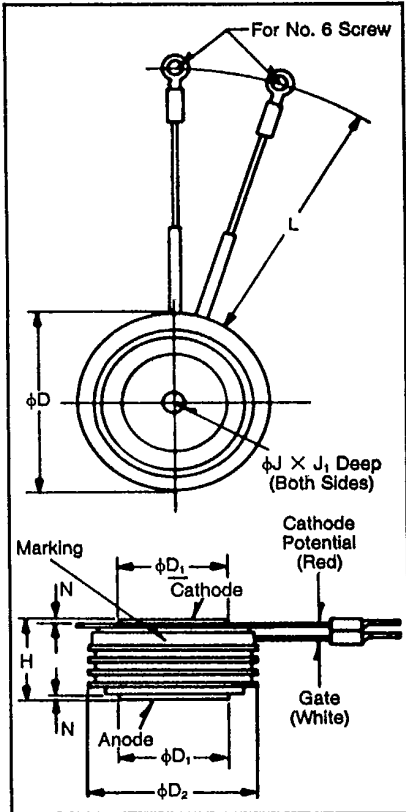

TA20
Phase Control SCR
 1600-1800 Amperes/100-2200 Volts

Description

Powerex Silicon Controlled Rectifiers (SCR) are designed for phase control applications. These are all-diffused, Press-Pak (Pow-R-Disc) devices employing the field-proven amplifying (di/namic) gate.

Features:

- Low On-State Voltage
- High di/dt
- High dv/dt
- Hermetic Packaging
- Excellent Surge and I²t Ratings

Applications:

- Power Supplies
- Battery Chargers
- Motor Control
- Light Dimmers
- VAR Generators

Ordering Information

Example: Select the complete eight digit part number you desire from the table - i.e. TA200816 is a 800 Volt, 1600 Ampere Phase Control SCR.

TA2
Outline Drawing

Dimensions	Inches		Millimeters	
	Min.	Max.	Min.	Max.
φD	3.910	3.950	99.31	100.33
φD ₁	2.470	2.480	62.74	63.00
φD ₂	3.440	3.560	87.38	90.42
H	1.260	1.300	32.00	33.02
φJ	.135	.145	3.43	3.68
J ₁	.075	.090	1.91	2.29
L	11.50	12.50	292.10	317.50
N	.050	—	1.27	—

Creep Distance—1.40 in. min. (35.56 mm)
 Strike Distance—.98 in. min. (24.89 mm).
 (In accordance with NEMA standards.)
 Finish—Nickel Plate.
 Approx. Weight—2.1 lb. (950 g).

1. Dimension "H" is a clamped dimension.

Type	Voltage*		Current	
	V _{ORM} V _{RRM}	Code	I _T (avg)	Code
TA20	100	01	1600	16
	200	02	1800	18
	400	04		
	600	06		
	800	08		
	1000	10		
	1200	12		
	1400	14		
	1600	16		
	1800	18		
	2000	20		
2200	22			

* All voltages not available in all current ratings.



Powerex, Inc., Hillis Street, Youngwood, Pennsylvania 15697 (412) 925-7272
 Powerex Europe, S.A., 428 Ave. G. Durand, BP107, 72003 LeMans, France (43) 72.75.15

TA20
Phase Control SCR
 1600-1800 Amperes Avg/100-2200 Volts

Absolute Maximum Ratings

	Symbol	TA20 _ _ 16	TA20 _ _ 18	Units
Maximum Blocking Voltage	V_{DRM}, V_{RRM}	2200	1800	Volts
RMS On-State Current	$I_{T(RMS)}$	2500	2820	Amperes
Average On-State Current	$I_{T(av)}$	1600	1800	Amperes
Peak One-Cycle Surge (Non-Repetitive) On-State Current (60Hz) [ⓐ]	I_{TSM}	29,500	40,000	Amperes
Peak One-Cycle Surge (Non-Repetitive) On-State Current (50Hz) [ⓐ]	I_{TSM}	26,900	36,500	Amperes
Critical Rate-of-Rise of On-State Current (Non-Repetitive) ^{ⓐ ⓑ}	di/dt	400	400	Amperes/μs
Critical Rate-of-Rise of On-State Current (Repetitive)	di/dt	150	150	Amperes/μs
I ² t (for Fusing), One Cycle at 60 Hz	I ² t	3.63 × 10 ⁶	6.67 × 10 ⁶	A ² sec
Peak Gate Power Dissipation	P _{GM}	16	16	Watts
Average Gate Power Dissipation	P _{G(av)}	3	3	Watts
Storage Temperature	T _{STG}	-40 to 150	-40 to 150	°C
Operating Temperature	T _J	-40 to 125	-40 to 125	°C
Mounting Force [ⓐ]		9000 to 11,000	9000 to 11,000	lb.
Mounting Force [ⓐ]		4100 to 5000	4100 to 5000	kg

Electrical and Thermal Characteristics

	Symbol	Test Conditions	TA20 _ _ 16	TA20 _ _ 18	Units
Current—Conducting State Maximums					
Peak On-State Voltage	V _{TM}	I _{TM} = 3000A, T _J = 25°C	1.75	1.45	Volts
TA20					
Voltage—Blocking State Maximums[ⓐ]					
Forward Leakage, Peak	I _{DRM}	T _J = 125°C, V _{DRM} = rated	100		mA
Reverse Leakage, Peak	I _{RRM}	T _J = 125°C, V _{RRM} = rated	100		mA
Switching					
Typical Turn-Off Time	t _q	I _T = 250A, T _J = 125°C, di _R /dt = 50A/μsec, reapplied dv/dt = 20V/μsec linear to 0.8V _{DRM}	250		μsec
Typical Turn-On Time [ⓐ]	t _{on}	I _{TM} = 1000A, V _D = 1500V	4.0		μsec
Min. Critical dv/dt exponential to V _{DRM} ^{ⓐ ⓑ}	dv/dt	T _J = 125°C	300		V/μsec
Thermal					
Maximum Thermal Resistance, [ⓐ] double sided cooling					
Junction to Case	R _{θJC}		.015		°C/Watt
Case to Sink, Lubricated	R _{θCS}		.007		°C/Watt
Gate—Maximum Parameters					
Gate Current to Trigger	I _{GT}	T _J = 25°C, V _D = 12V	200		mA
Gate Voltage to Trigger	V _{GT}	T _J = 25°C, V _D = 12V	3.0		Volts
Non-Triggering Gate Voltage	V _{GDM}	T _J = 125°C, rated V _{DRM}	.15		Volts
Peak Forward Gate Current	I _{GTM}		4		Amperes
Peak Reverse Gate Voltage	V _{GRM}		5		Volts

ⓐ Consult recommended mounting procedures.
 ⓑ Applies for zero or negative gate bias.
 ⓐ Per JEDEC RS-397, 5.2.2.1.
 ⓐ With recommended gate drive.
 ⓐ Higher dv/dt ratings available, consult factory.
 ⓐ Per JEDEC standard RS-397, 5.2.2.6.



Powerex, Inc., Hillis Street, Youngwood, Pennsylvania 15697 (412) 925-7272
 Powerex Europe, S.A., 428 Ave. G. Durand, BP107, 72003 LeMans, France (43) 72.75.15

TA20
 Phase Control SCR
 1600-1800 Amperes Avg/100-2200 Volts

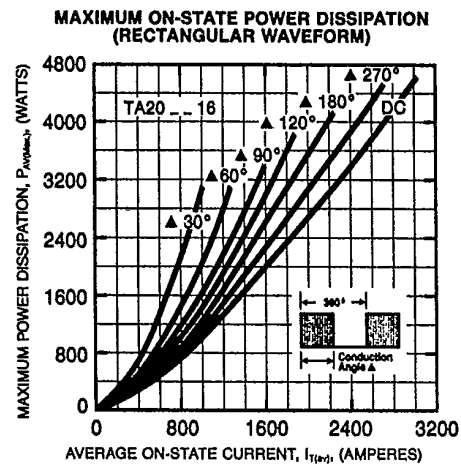
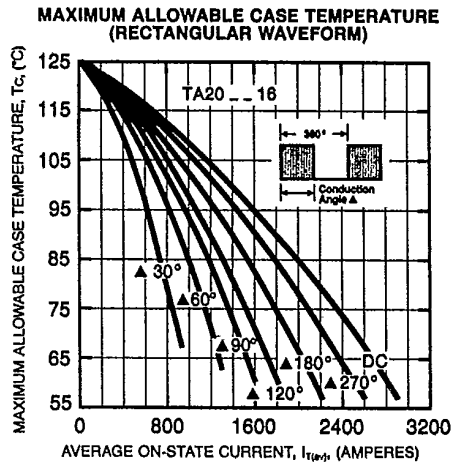
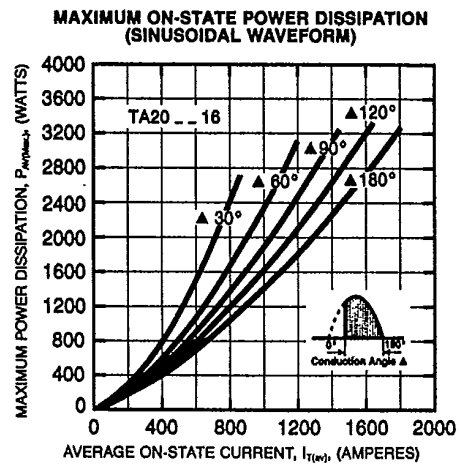
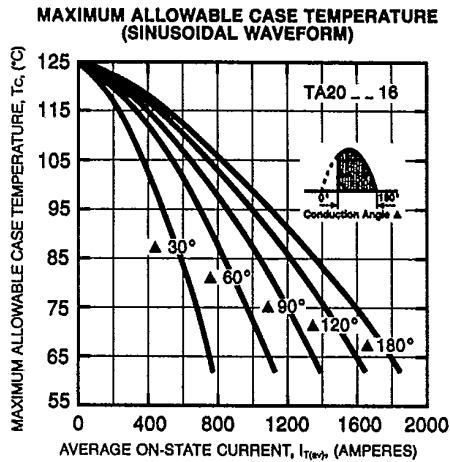
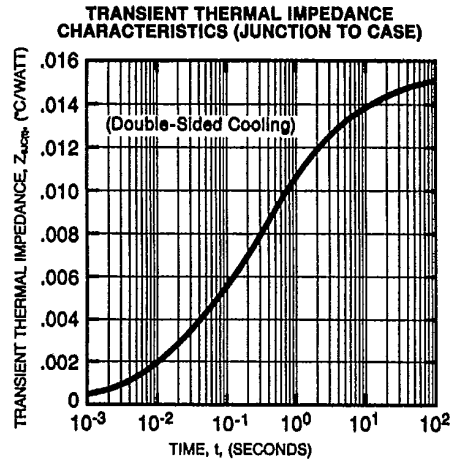
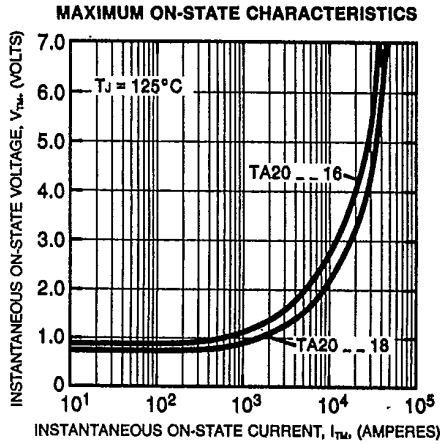



Powerex, Inc., Hillis Street, Youngwood, Pennsylvania 15697 (412) 925-7272
 Powerex Europe, S.A., 428 Ave. G. Durand, BP107, 72003 LeMans, France (43) 72.75.15

TA20
Phase Control SCR
 1600-1800 Amperes Avg/100-2200 Volts

