

TOSHIBA Bipolar Integrated Circuit Silicon Monolithic

# TA2123AF

## 1.5V Stereo Headphone Amplifier

The TA2123AF is the system amplifier IC which is developed for playback stereo headphone equipments. It is built in dual auto-reverse preamplifiers, dual power amplifiers with bass / treble boost function, AMS (automatic music sensor) function, beep function, AGC for power amplifier etc.

### Features

- Power amplifier stage
  - In case of output coupling type, the supply current decreases.  
(built-in center amplifier switch)
  - Built-in bass boost function
  - Built-in treble boost function
  - Built-in power amplifier muting function
  - Built-in input terminal for beep signal
  - Built-in input capacitor for reducing buzz noise
  - $G_V = 24\text{dB}$  (typ.)
  - Built-in AGC circuit (in case of boost mode, this circuit operates.)
- Low supply current  
( $V_{CC} = 1.3\text{V}$ ,  $f = 1\text{kHz}$ ,  $R_L = 32\Omega$ ,  $T_a = 25^\circ\text{C}$ , typ.)

	No Signal	0.1mW × 2	0.5mW × 2
Output coupling type	1.5mA	3.0mA	5.0mA
OCL type	2.2mA	4.9mA	8.6mA

- Preamplifier stage
  - Auto-reverse compatible
  - Built-in input capacitor for reducing buzz noise
  - Input coupling condenser-less
  - Built-in metal mode drivers
  - Preamplifier muting function
- Built-in ripple filter circuit
- Built-in AMS (automatic music sensor) function (mixer amplifier and level comparator)
- Built-in power switch
- Operating supply voltage range ( $T_a = 25^\circ\text{C}$ )  
 $V_{CC}(\text{opr}) = 0.95\sim 2.2\text{V}$

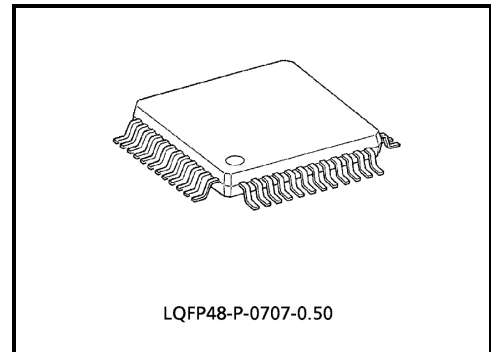

Weight: 0.17g (typ.)

## Block Diagram

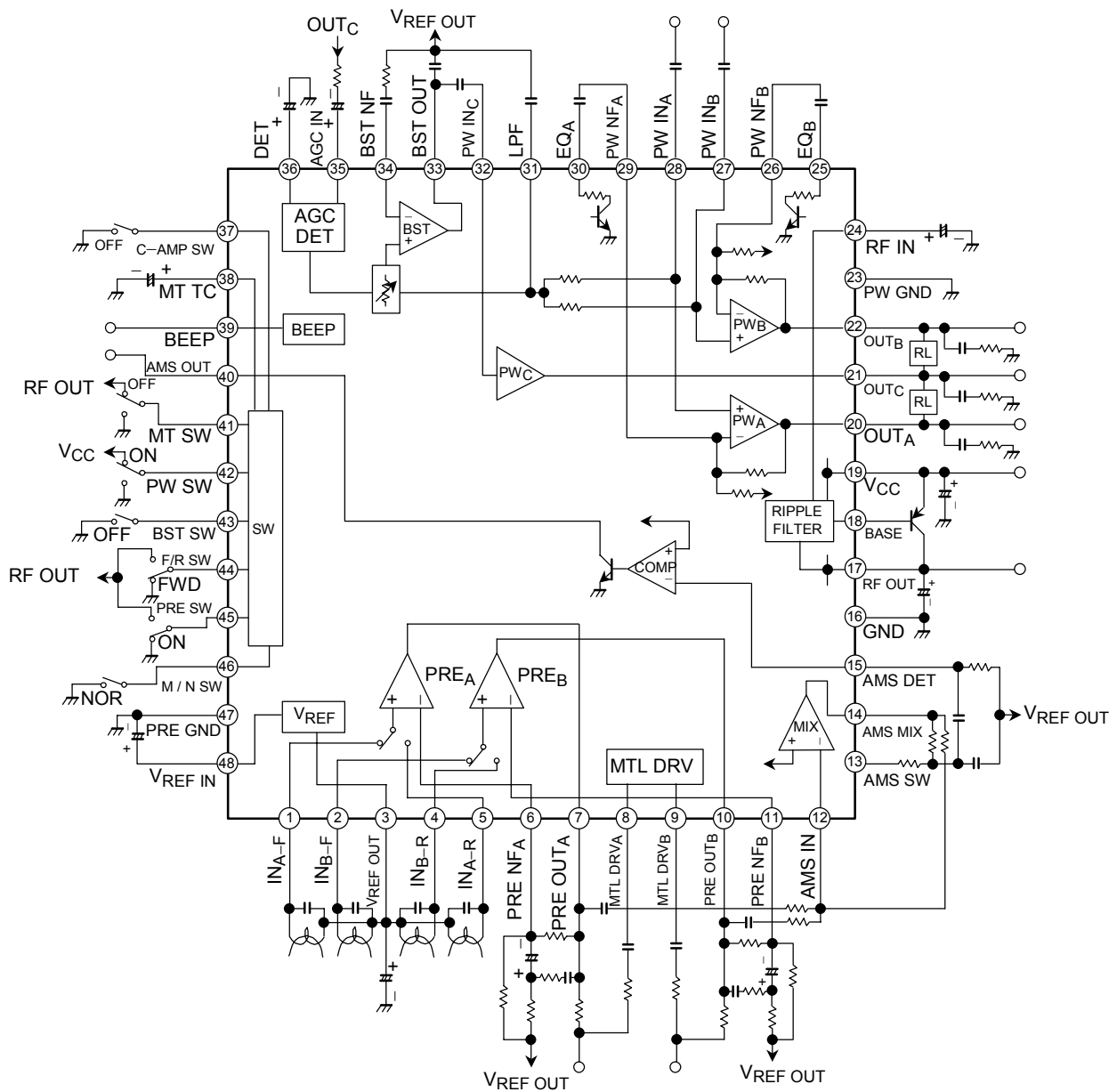

**Terminal Explanation**

(terminal voltage: Typical terminal voltage at no signal with test circuit,  $V_{CC} = 1.3V$ ,  $T_a = 25^\circ C$ )

Terminal		Function	Internal Circuit	Terminal Voltage (V)
No.	Name			
1	IN <sub>A-F</sub>	Input of preamplifier F / R SW (pin 44) "L" level: Pin 1 / 2 "H" level: Pin 4 / 5 Refer to application note 3 (2)		0.73
2	IN <sub>B-F</sub>			
4	IN <sub>B-R</sub>			
5	IN <sub>A-R</sub>			
6	PRE NFA	NF of preamplifier		0.7
11	PRE NFB			
3	V <sub>REF OUT</sub>	Output of reference circuit		0.73
48	V <sub>REF IN</sub>	Input of reference circuit		
7	PRE OUT <sub>A</sub>	Output of preamplifier		0.44
10	PRE OUT <sub>B</sub>			
8	MTL DRV <sub>A</sub>	Metal driver terminal On resistance: 90Ω (typ.)		—
9	MTL DRV <sub>B</sub>			
12	AMS IN	Input of mixer amplifier for AMS signal		0.7
14	AMS MIX	Output of mixer amplifier for AMS signal		
13	AMS SW	AMS sensitivity changeover switch (this switch synchronizes with the MT SW)	<p>MT SW ON : CURRENT SOURCE→ON MT SW OFF : CURRENT SOURCE→OFF</p>	—

Terminal		Function	Internal Circuit	Terminal Voltage (V)
No.	Name			
15	AMS DET	Input of AMS comparator circuit		0.73
40	AMS OUT	Output of AMS comparator circuit High level: Rectangular pulse Low level: "H"		—
16	GND	—	—	0
17	RF OUT	Output of ripple filter • Ripple filter circuit supplies internal circuit except power drive stage with power source		1.22
18	BASE	Base biasing terminal of transistor for ripple filter		0.5
19	VCC	—		1.3
24	RF IN	Ripple filter terminal		1.23
20	OUT <sub>A</sub>	Output of power amplifier		0.56
22	OUT <sub>B</sub>			0.73
26	PW NF <sub>B</sub>	NF of power amplifier		0.73
29	PW NF <sub>A</sub>	Input of power amplifier (this terminal also has function of an ADD amplifier input.)		0.73
27	PW IN <sub>B</sub>			0.73
28	PW IN <sub>A</sub>	0.73		
21	OUT <sub>C</sub>	Output of center amplifier		0.56
32	PW IN <sub>C</sub>	Input of center amplifier		0.73
23	PW GND	Power GND for power drive stage	—	0
25	EQ <sub>B</sub>	Equalizer circuit (this circuit synchronizes with the BST SW) • Input impedance : 1.9Ω (typ.)		—
30	EQ <sub>A</sub>			—

Terminal		Function	Internal Circuit	Terminal Voltage (V)
No.	Name			
31	LPF	Low pass filter terminal of bass boost		0.73
33	BST OUT	Output of boost amplifier		0.73
34	BST NF	NF of boost amplifier		0.73
35	AGC IN	Input of boost AGC circuit <ul style="list-style-type: none"> <li>The input level to the boost amplifier is controlled by the input level of this terminal.</li> <li>Input impedance: 10kΩ (typ.)</li> </ul>		0.73
36	DET	Smoothing terminal of boost AGC circuit		—
37	C-AMP SW	Center amplifier on / off switch <ul style="list-style-type: none"> <li>Output type of power amplifier OCL type: OPEN (C-AMP ON)</li> <li>Output coupling type: GND (C-AMP OFF)</li> </ul>		—
38	MT TC	Smoothing terminal of MT SW In order to reduce a pop noise at power amplifier on / off switching		0.7

Terminal		Function	Internal Circuit	Terminal Voltage (V)
No.	Name			
39	BEEP	Input of beep signal <ul style="list-style-type: none"> <li>This terminal receives beep signal of a microcomputer etc.</li> <li>This terminal should be set as high impedance or "H" when not using this function</li> </ul>		0.7
41	MT SW	Muting switch of power amplifier Power amp. on: "H" level Power amp. off: "L" level Refer to application note 3 (2)		—
44	F / R SW	Forward / reverse switch Forward: "L" level Reverse: "H" level Refer to application note 3 (2)		—
45	PRE SW	Muting switch of preamplifier Preamp. on: "L" level Preamp. off: "H" level Refer to application note 3 (2)		—
42	PW SW	Power on / off switch IC on: "H" level IC off: "L" level Refer to application note 3 (2)		—
43	BST SW	Boost on / off switch BST on: OPEN / "H" level BST off: "L" level Refer to application note 3 (2)		—
46	M / N SW	Metal / normal mode switch Metal mode: OPEN / "H" level Normal mode: "L" level Refer to application note 3 (2)		—
47	PRE GND	Power GND for power drive stage	—	0

**Application Note**

1. Preamplifier stage

(1) Output DC voltage of preamplifier

Output DC voltage of preamplifier is determined by external resistors R1 and R2 as shown in Fig.1.

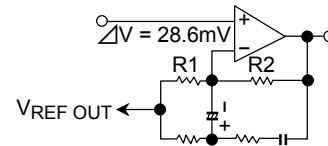

Fig.1 Output DC voltage of preamplifier

$$V_O (PRE) = V_{REF OUT} - \Delta V \times (R_2 / R_1 + 1)$$

- $V_{REF OUT} = 0.73V$  (typ.)
- $\Delta V$  is an offset voltage which is designed to 28.6mV.

It is as follows in case that the DC voltage is calculated by the constant of a test circuit.

$$V_O (PRE) = 0.73V - 28.6mV (200k\Omega / 22k\Omega + 1) = 0.44V$$

Output DC voltage of preamplifier should be fixed about  $V_{CC} / 2$ , because preamplifier get a enough dynamic range.

(2) AMS (automatic music sensor) function

A block diagram is shown in Fig.2. This function can AMS (automatic music sensor) and BS (blank skip).

- The comparator input level is higher than comparator sensitivity.  
→Rectangle wave is outputted.
- The comparator input level is lower than comparator sensitivity.  
→High level is outputted.

The sensitivity changeover is determined by AMS switch (the comparator sensitivity doesn't change.).

- Automatic music sensor mode

The AMS SW is also turned on when the MT SW is turned on. And the comparator input level is determined by external resistors (R4~R6) and capacitors (C3, C4) from mixer amplifier output level.

The transfer function is as follows.

$$V_O / V_i = R_3 / [R_1 \cdot R_2 / (R_1 + R_2)] \times \{j\omega C_4 \cdot R_5 \cdot R_6 / [R_4 \cdot R_5 + j\omega (C_3 \cdot R_4 \cdot R_5 + C_4 \cdot R_4 \cdot R_5 + C_4 \cdot R_4 \cdot R_6 + C_4 \cdot R_5 \cdot R_6)] - \omega^2 C_3 \cdot C_4 \cdot R_4 \cdot R_5 \cdot R_6\}$$

- Blank skip mode  
The AMS SW is also turned off when the MT SW is turned off. And the comparator input level is determined by external resistors (R4, R6) and capacitors (C3, C4) from mixer amplifier output level.

The transfer function is as follows.

$$V_O / V_i = R_3 / [R_1 \cdot R_2 / (R_1 + R_2)] \times \{j\omega C_4 \cdot R_6 / [1 + j\omega (C_3 \cdot R_4 + C_4 \cdot R_4 + C_4 \cdot R_6) - \omega^2 C_3 \cdot C_4 \cdot R_4 \cdot R_6]\}$$

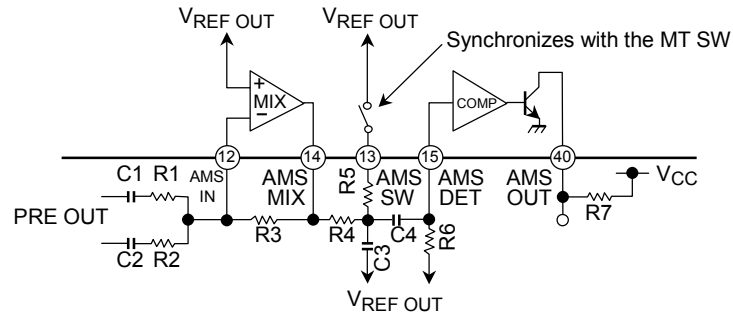

Fig.2 AMS system



2. Power amplifier stage

(1) Input of power amplifier

Each input signal should be applied through a capacitor. In case that DC current or DC voltage is applied to each amplifier, the internal circuit has unbalance and the each amplifier doesn't operate normally.

It is advised that input signal refer to VREF voltage, in order to reduce a pop noise or low frequency leak.

(2) Output application

This IC can chose the output coupling type and OCL type. The C-AMP SW should be connected to GND in case that the output coupling type is chosen. The supply current decreases when not using the bass boost function.

(3) Bass boost function

(a) System

This IC has the bass boost function in power amplifier stage. After this system adds the low frequency ingredient of side amplifier, it is applied into the center amplifier. And the bass boost level is controlled by the variable impedance circuit (Fig.3)

- Flow of the bass boost signal  
Variable impedance circuit → Boost amplifier → Center amplifier
- Flow of the bass boost level  
Output of center amplifier → AGC DET (level detection) → Variable impedance circuit operation

The system of treble boost function is realized by frequency characteristic adjustment of the side amplifier.

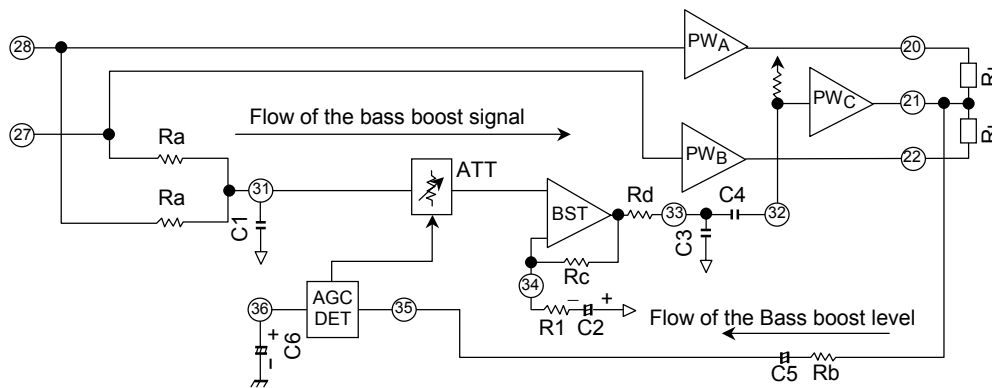

Fig.3 Bass boost system

(b) AGC circuit

The AGC circuit of bass boost function is realized by the variable impedance circuit. The AGC DET circuit detects the low frequency level of center amplifier. When this level becomes high, the variable impedance circuit operates, and this circuit attenuates the input level of center amplifier.

The AGC DET circuit is the current input, so that the output voltage of ADD amplifier is changed into the current ingredient by resistor Rb and capacitor C5 which are shown in Fig.3. And it is smoothed and detected by DET circuit (pin 36). And the direct current should not be applied to the AGC IN circuit, because, as for the circuit, the sensitivity setup is high.

Moreover, the AGC signal level is decreased in case that the resistor R5 is connected with the capacitor C5 in series. And the AGC point can be changed. But the center amplifier is clipped in the low frequency in case that the resistor R5 is larger.

(c) Bass boost

The signal flow of bass boost function is as follows, refer to Fig.4.

LPF (internal resistors 2R1 and external capacitor C1)

→ATT (variable impedance circuit)

→HPF (BST amplifier)

→BPF (LPF: internal resistor R4 and external capacitor C3, HPF: external capacitor C4 and internal resistor R5)

→Center amplifier

The center amplifier signal becomes the reverse phase, because the phase of audio frequency range is reversed with two LPFs.

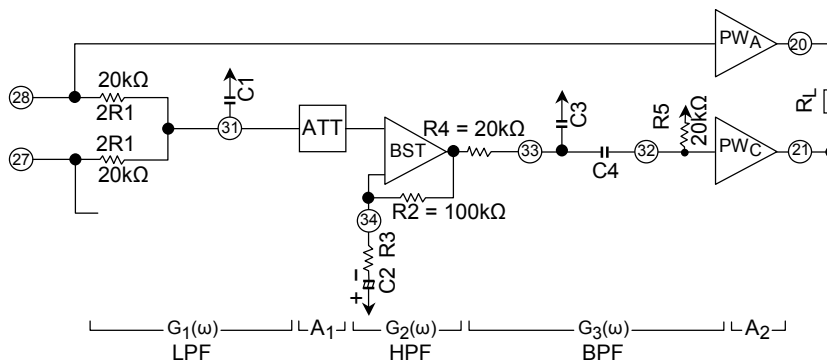

Fig.4 Block diagram of bass boost

The transfer function of bass boost is as follows from Fig.4.

$$G(\omega) = G_1(\omega) \cdot A_1 \cdot G_2(\omega) \cdot G_3(\omega) \cdot A_2$$

The bass boost effect is changed by external resistor or external capacitor. The transfer function and cut off frequency are as follows.

(1) Transfer function of LPF

$$G_1(\omega) = 1 / (1 + j\omega C_1 \cdot R_1)$$

$$f_L = 1 / 2\pi C_1 \cdot R_1$$

(2) Transfer function of BPF

$$G_3(\omega) = j\omega C_4 \cdot R_5 / [1 + j\omega (R_4 \cdot C_3 + R_5 \cdot C_3 + C_4 \cdot R_4) - \omega^2 R_4 \cdot C_3 \cdot R_5 \cdot C_4]$$

$$f_O = 1 / 2\pi \sqrt{R_4 \cdot C_3 \cdot R_5 \cdot C_4}$$

(3) HPF gain and cut off frequency

$$G_2(\omega) = 1 + R_2 / (R_3 + 1 / j\omega C_2)$$

$$f_{HC} = 1 / (2\pi R_3 \cdot C_2)$$

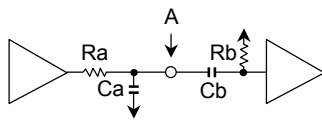
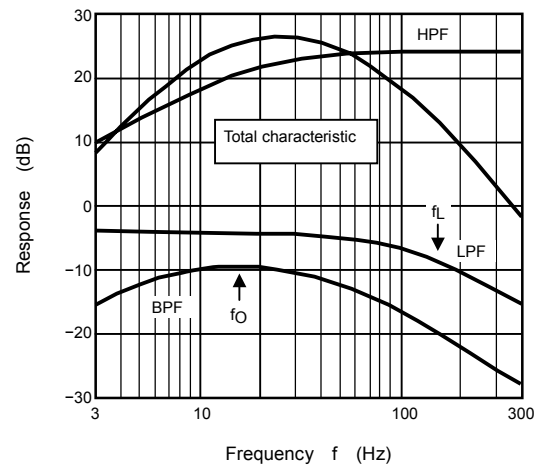

Fig.5 BPF



Graph.1 Characteristic of bass boost

(4)  $f_O$  and  $f_L$

The  $f_L$  and  $f_O$  should be set up out of the audio frequency range. In case that the  $f_O$  and  $f_L$  is inside of audio frequency range and AGC circuit operates, the voltage gain decrease.

(5) HPF

The  $f_{HC}$  should be made 1 / 2 or less frequency as compared with the  $f_L$  or  $f_O$ . The phase difference is large near the  $f_{HC}$ , so that the bass boost level runs short. And the HPF gain of middle or high frequency range should be set to 10dB or more.

(4) Treble boost

The EQ terminal is synchronizes with the BST SW, and the input impedance is changed.

BST OFF: 100kΩ (typ.)

BST ON: 1.9kΩ (typ.)

The voltage gain increase 6 dB (typ.) at high frequency range in case that the capacitor CX is connected between the EQ terminal and the PW NF terminal.

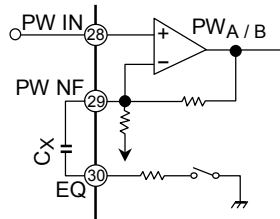

Fig.6 Treble boost

(5) Cross talk of output coupling type

In case of output coupling mode, the cross talk is determined by resistor  $R_L$  and capacitor C which are connected with power amplifier output as shown in Fig.7.

The formula is shown below.

$$G(\omega) = 1 / 2 [1 + j\omega C (R_L / 2)]$$

$$CT = 20 \log |G_V| = 20 \log [1 / 2 [\sqrt{1 + (\omega / \omega_0)^2}]], \omega_0 = 1 / C (R_L / 2)$$

At  $f = 1\text{kHz}$ ,  $C = 220\mu\text{F}$ ,  $R_L = 32\Omega$ , The cross talk becomes about 33 dB.

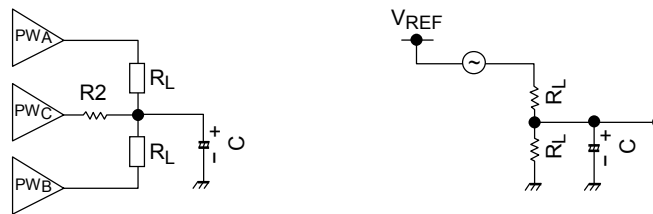

Fig.7 Cross talk of output coupling type

3. Total

(1) Ripple filter

It is necessary to connect a low saturation transistor (2SA1362 etc.) for ripple filter, because this IC doesn't have transistor for ripple filter. Care should be taken to stabilize the ripple filter circuit, because the ripple filter circuit supplies internal circuit except power drive stage with power source.

(2) Switch terminal

(a) PW SW

It is necessary to connect an external pull-down resistor with terminal PW SW, in case that this IC is turned on due to external noise etc. (The PW SW sensitivity is designed highly.)

(b) MT SW, BST SW, F / R SW, PRE SW, M / N SW

The current flows through terminals of MT SW, BST SW, PRE SW and M / N SW, in case that these terminals are connected with VCC line independently, even though the PW SW is off-mode. It is necessary to connect an external pull-down resistor with each terminals in case that IC is turned on due to external noise etc. These switches are designed highly.)

- The pop noise at turning on / off MT SW can be reduced by the external capacitor of the MT TC terminal.

(c) C-AMP SW

The C-AMP SW terminal should not be connected with high voltage of VCC etc., because internal circuit is broken.

(d) Sensitivity voltage of each switch (Ta = 25°C)

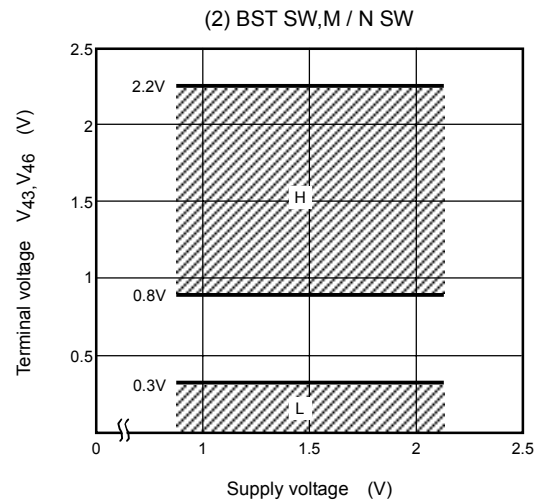
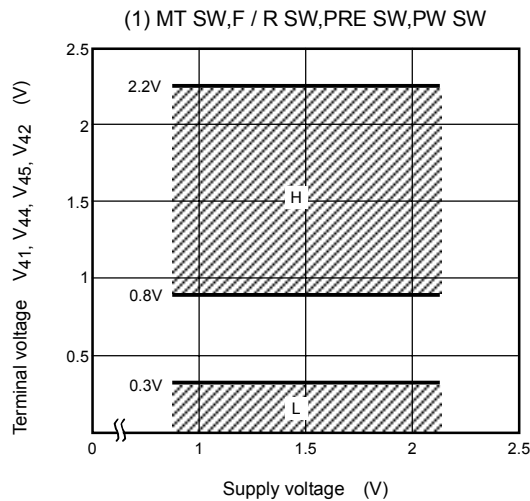

	MT SW (V <sub>41</sub> )	F / R SW (V <sub>44</sub> )	PRE SW (V <sub>45</sub> )	PW SW (V <sub>42</sub> )
'H'	Muting OFF	REV mode	Preamp. OFF	IC ON
'L'	Muting ON	FWD mode	Preamp. ON	IC OFF

	BST SW (V <sub>43</sub> )	M / N SW (V <sub>46</sub> )
'H', open	BST ON	Metal mode
'L'	BST OFF	Normal mode

## (3) Capacitor

Small temperature coefficient and excellent frequency characteristic is needed by capacitor below.

- Oscillation preventing capacitors for power amplifier output
- Capacitor between VREF and GND
- Capacitor between VCC and GND
- Capacitor between RF OUT and GND

**Maximum Ratings (Ta = 25°C)**

Characteristic	Symbol	Rating	Unit
Supply voltage	V <sub>CC</sub>	4.5	V
Output current (PW AMP.)	I <sub>O</sub> (peak)	100	mA
Power dissipation	P <sub>D</sub> (Note)	750	mW
Operating temperature	T <sub>opr</sub>	-25~75	°C
Storage temperature	T <sub>stg</sub>	-55~150	°C

Note: Derated above Ta = 25°C in proportion of 6mW / °C

## Electrical Characteristics

Unless Otherwise Specified:  $V_{CC} = 1.3V$ ,  $T_a = 25^\circ C$ ,  $f = 1kHz$ , SW1: b, SW2: b, SW3: a, SW4: OPEN SW5: a, SW6: a, SW7: ON, SW8: a / b, SW9: b, SW10: ON

Preamplifier: Normal Mode,  $R_g = 2.2k\Omega$ ,  $R_L = 10k\Omega$ , SW1: a  
Power Amplifier:  $R_g 600\Omega$ ,  $R_L = 32\Omega$ , SW2: a

Characteristic	Symbol	Test Circuit	Test Condition	Min.	Typ.	Max.	Unit	
Quiescent supply current 1	$I_{CCQ1}$	—	OCL mode, PRE + PW	—	2.2	4.0	mA	
Quiescent supply current 2	$I_{CCQ2}$	—	OCL mode, PRE: OFF SW9: a	—	1.7	3.0		
Quiescent supply current 3	$I_{CCQ3}$	—	Coupling mode PRE + PW, SW4: ON	—	1.5	2.7		
Quiescent supply current 4	$I_{CCQ4}$	—	Coupling mode PRE : OFF, SW4: ON SW9: a	—	1.0	1.8		
Preamp. stage	Open loop voltage gain	$G_{VO}$	—	$V_o = -22dBV$ NF resistor (150 $\Omega$ ): Short	65	80	—	dB
	Closed loop voltage gain	$G_{VC}$	—	$V_o = -22dBV$	—	35	—	
	Maximum output voltage	$V_{om1}$	—	THD = 1%	160	250	—	mV <sub>rms</sub>
	Total harmonic distortion	THD1	—	$V_{CC} = 1V$ , $V_o = -22dBV$	—	0.08	0.3	%
	Equivalent input noise voltage	$V_{ni}$	—	$R_g = 2.2k\Omega$ BPF: 20Hz~20kHz NAB ( $G_V = 35dB$ , $f = 1kHz$ ) SW1: b	—	1.7	2.7	$\mu V_{rms}$
	Cross talk (CH-A / CH-B)	CT1	—	$V_o = -22dBV$	—	60	—	dB
	Cross talk (forward / reverse)	CT2	—		—	62	—	
	Ripple rejection ratio	RR1	—	$f_r = 100Hz$ , $V_r = -32dBV$ BPF = 100Hz	—	54	—	
	Preamplifier muting attenuation	ATT1	—	$V_o = -22dBV$ SW9: b→a	—	84	—	
	Driver on resistance	R1	—	$I_L = 100\mu A$ , SW10: OPEN	—	90	—	$\Omega$
AMS sensitivity 1	AMS1	—	SW5: b	-58.3	-56.3	-54.3	dBV	
AMS sensitivity 2	AMS2	—	SW5: a	-69.7	-67.7	-65.7		
Forward mode on voltage	$V_{44}$	—	$V_{CC} = 0.95V$	0	—	0.3	V	
Reverse mode on current	$I_{44}$	—		5	—	—	$\mu A$	
Preamplifier on voltage	$V_{45}$	—		0	—	0.3	V	
Preamplifier off current	$I_{45}$	—		5	—	—	$\mu A$	
Metal mode on voltage	$V_{46 (M)}$	—		0.8	—	0.95	V	
Normal mode on voltage	$V_{46 (N)}$	—		0	—	0.3	V	

Characteristic	Symbol	Test Cir-cuit	Test Condition	Min.	Typ.	Max.	Unit	
Power amp. stage	Voltage gain 1	G <sub>V1</sub>	V <sub>o</sub> = -22dBV	—	24	—	dB	
	Channel balance	CB		-1.5	0	+1.5		
	Voltage gain 2	G <sub>V2</sub>	V <sub>in (A)</sub> = V <sub>in (B)</sub> = -V <sub>in (C)</sub> V <sub>o</sub> = -22dBV	28	30	32		
	Output power	P <sub>o</sub>	—	V <sub>CC</sub> = 1.5V THD (A) = THD (B) = 10%	3	6	—	mW
	Total harmonic distortion	THD	—	P <sub>o</sub> = 1mW	—	0.1	0.8	%
	Output noise voltage	V <sub>no</sub>	—	R <sub>g</sub> = 600Ω, SW2: b BPF = 20Hz~20kHz	—	40	80	μV <sub>rms</sub>
	Cross talk	CT3	—	V <sub>o</sub> = -22dBV	34	43	—	dB
	Ripple rejection ratio	RR2	—	V <sub>CC</sub> = 1V, f <sub>r</sub> = 100Hz V <sub>r</sub> = -32dBV, BPF = 100Hz	—	70	—	
	Power amplifier muting attenuation	ATT2	—	V <sub>o</sub> = -22dBV SW5: a→b	—	72	—	
	Beep signal input sensitivity	SEN	—	V <sub>o</sub> = -62dBV, SW5: OPEN	0.7	1.3	2.2	μA <sub>p-p</sub>
Boost amp. stage	Voltage gain 3	G <sub>V3</sub>	—	f = 40Hz, V <sub>in</sub> = -64dBV SW7: Open Monitor: C-AMP. -GND	41	44	47	dB
	Voltage gain 4	G <sub>V4</sub>	—	f = 40Hz, V <sub>in</sub> = -47dBV SW7: Open Monitor: C-AMP. -GND	27.5	30.5	33.5	
	Maximum output voltage	V <sub>om2</sub>	—	f = 40Hz, THD = 1% SW3: b, SW7: Open	—	86	—	mV <sub>rms</sub>
	Muting attenuation	ATT3	—	f = 40Hz, V <sub>o</sub> = -32dBV SW7: Open→on	—	53	—	dB
	Equalizer on resistance	R2	—	I <sub>L</sub> = 100μA, SW7: Open	—	1.9	—	kΩ
Ripple filter output voltage	V <sub>RF OUT</sub>	—	V <sub>CC</sub> = 1V, I <sub>RF</sub> = 20mA	0.89	0.92	—	V	
Ripple filter ripple rejection ratio	RR3	—	V <sub>CC</sub> = 1V, I <sub>RF</sub> = 20mA BPF = 100Hz, f <sub>r</sub> = 100Hz V <sub>r</sub> = -32dBV	35	42	—	dB	
Power amplifier on current	I <sub>41</sub>	—	V <sub>CC</sub> = 0.95V	5	—	—	μA	
Power amplifier off voltage	V <sub>41</sub>	—		0	—	0.3	V	
Power on current	I <sub>42</sub>	—		5	—	—	μA	
Power off voltage	V <sub>42</sub>	—		0	—	0.3	V	
Boost on voltage	V <sub>43 (ON)</sub>	—		0.8	—	0.95	V	
Boost off voltage	V <sub>43 (OFF)</sub>	—		0	—	0.3	V	



## Test Circuit (preamplifier stage)

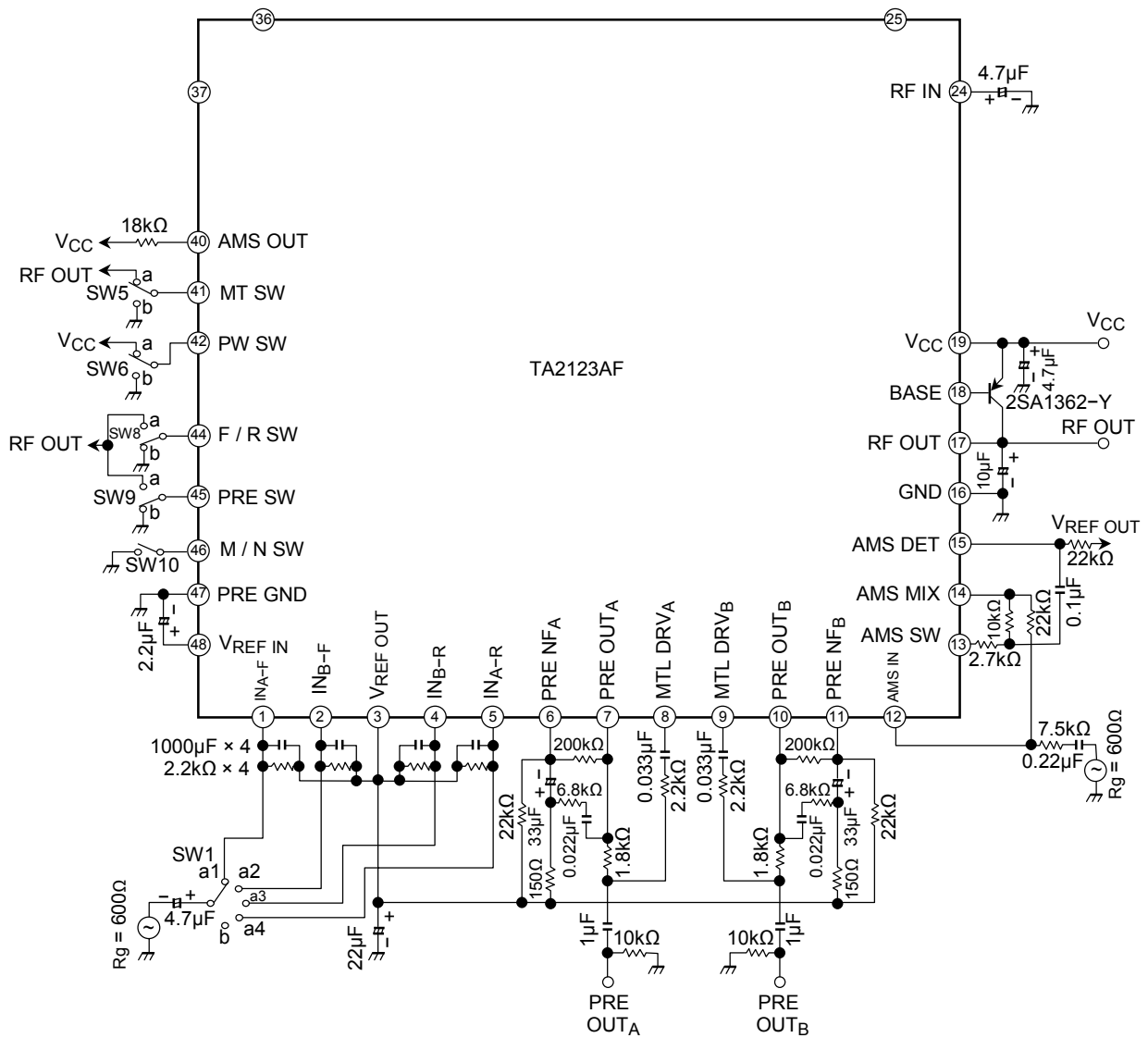

**Test Circuit (power amplifier stage)**

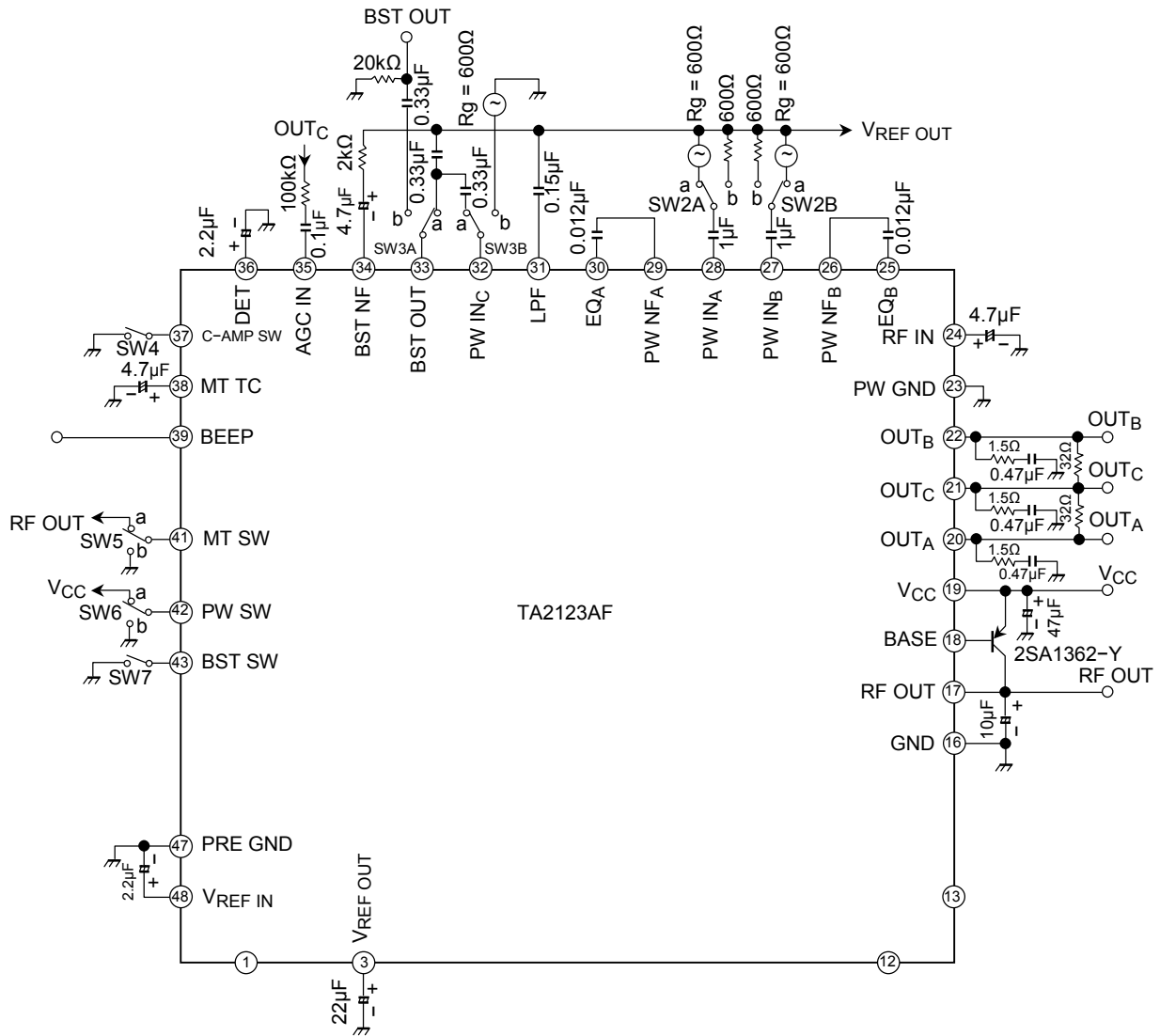

Output circuit of output coupling type

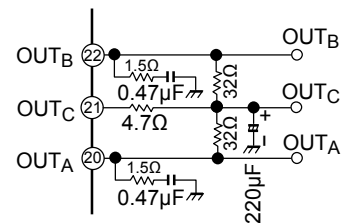

**Package Dimensions**

LQFP48-P-0707-0.50

Unit : mm

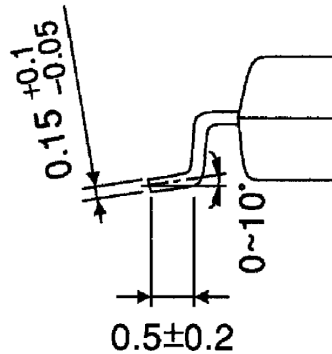
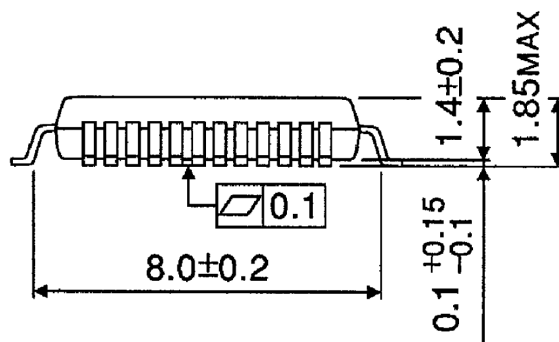
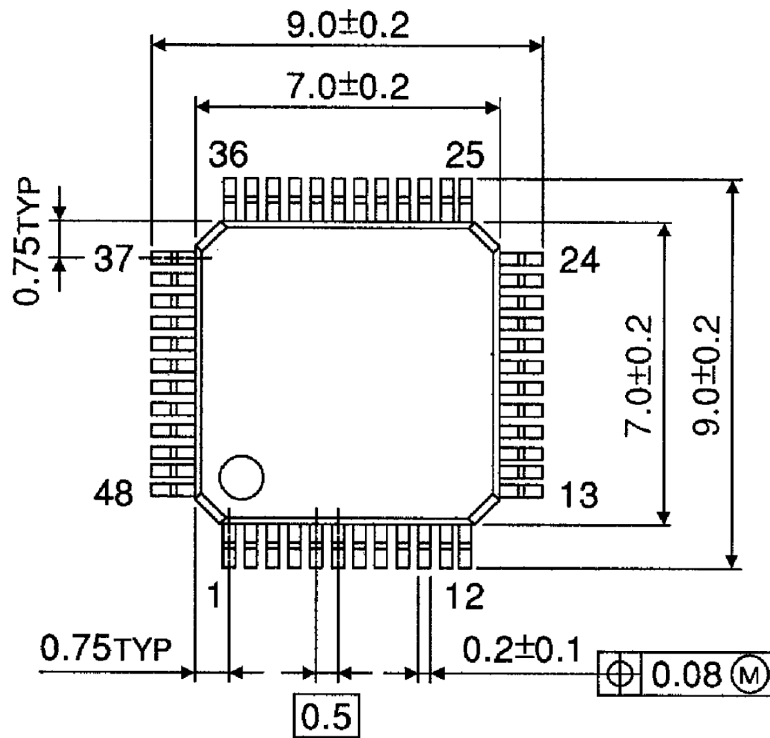

Weight: 0.17g (typ.)

**RESTRICTIONS ON PRODUCT USE**

000707EBA

- TOSHIBA is continually working to improve the quality and reliability of its products. Nevertheless, semiconductor devices in general can malfunction or fail due to their inherent electrical sensitivity and vulnerability to physical stress. It is the responsibility of the buyer, when utilizing TOSHIBA products, to comply with the standards of safety in making a safe design for the entire system, and to avoid situations in which a malfunction or failure of such TOSHIBA products could cause loss of human life, bodily injury or damage to property.  
In developing your designs, please ensure that TOSHIBA products are used within specified operating ranges as set forth in the most recent TOSHIBA products specifications. Also, please keep in mind the precautions and conditions set forth in the "Handling Guide for Semiconductor Devices," or "TOSHIBA Semiconductor Reliability Handbook" etc..
- The TOSHIBA products listed in this document are intended for usage in general electronics applications (computer, personal equipment, office equipment, measuring equipment, industrial robotics, domestic appliances, etc.). These TOSHIBA products are neither intended nor warranted for usage in equipment that requires extraordinarily high quality and/or reliability or a malfunction or failure of which may cause loss of human life or bodily injury ("Unintended Usage"). Unintended Usage include atomic energy control instruments, airplane or spaceship instruments, transportation instruments, traffic signal instruments, combustion control instruments, medical instruments, all types of safety devices, etc.. Unintended Usage of TOSHIBA products listed in this document shall be made at the customer's own risk.
- The products described in this document are subject to the foreign exchange and foreign trade laws.
- The information contained herein is presented only as a guide for the applications of our products. No responsibility is assumed by TOSHIBA CORPORATION for any infringements of intellectual property or other rights of the third parties which may result from its use. No license is granted by implication or otherwise under any intellectual property or other rights of TOSHIBA CORPORATION or others.
- The information contained herein is subject to change without notice.