

# TA2145AF

## 3 V Stereo Headphone Amplifier (3 V USE)

The TA2145AF is developed for play-back stereo headphone equipments (3 V USE).

It is built in dual preamplifiers, dual OCL power amplifiers, motor governor, DC volume control and preamplifier on/off switch etc.

### Features

- Built-in preamplifier
  - Input coupling condenser-less
  - Built-in input capacitor for reducing buzz noise
  - Low noise:  $V_{ni} = 1.2 \mu\text{Vrms}$  (typ.)
  - Preamplifier on/off switch.
- Built-in power amplifier
  - OCL (Output condenser-less)
  - Voltage gain:  $G_V = 31 \text{ dB}$  (typ.)
- Built-in motor governor (Current proportion type)
- Built-in DC volume control function
  - ATT = 82dB ( $T_a = 25^\circ\text{C}$ , typ.)
- Built-in bass boost function
- Low supply current ( $V_{CC} = 3 \text{ V}$ ,  $f = 1 \text{ kHz}$ , PRE OUT = 100 mVrms,  $T_a = 25^\circ\text{C}$ , typ.)
  - Quiescent supply current
    - PRE + PW:  $I_{CCQ} = 8.5 \text{ mA}$
    - GVN:  $I_{CC} = 2.5 \text{ mA}$
  - 0.1 mW  $\times$  2 ch output
    - $I_{CC1} = 9.8 \text{ mA}$  ( $R_L = 32 \Omega$ )
    - $I_{CC2} = 10.5 \text{ mA}$  ( $R_L = 16 \Omega$ )
  - 0.5 mW  $\times$  2 ch output
    - $I_{CC3} = 14.0 \text{ mA}$  ( $R_L = 32 \Omega$ )
    - $I_{CC4} = 16.5 \text{ mA}$  ( $R_L = 16 \Omega$ )
- Operating supply voltage range ( $T_a = 25^\circ\text{C}$ )
  - $V_{CC}(\text{opr}) = 1.8\sim 3.6 \text{ V}$
  - GVN  $V_{CC}(\text{opr}) = 2.1\sim 3.6 \text{ V}$  (Motor voltage = 1.8 V)

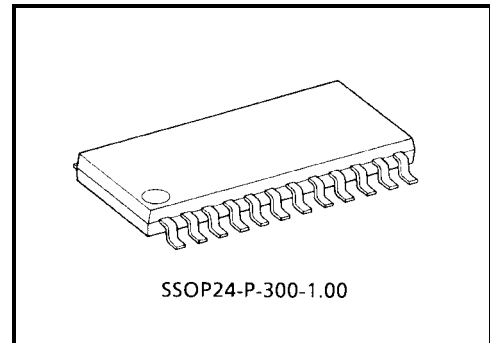

Weight: 0.32 g (typ.)

## Block Diagram

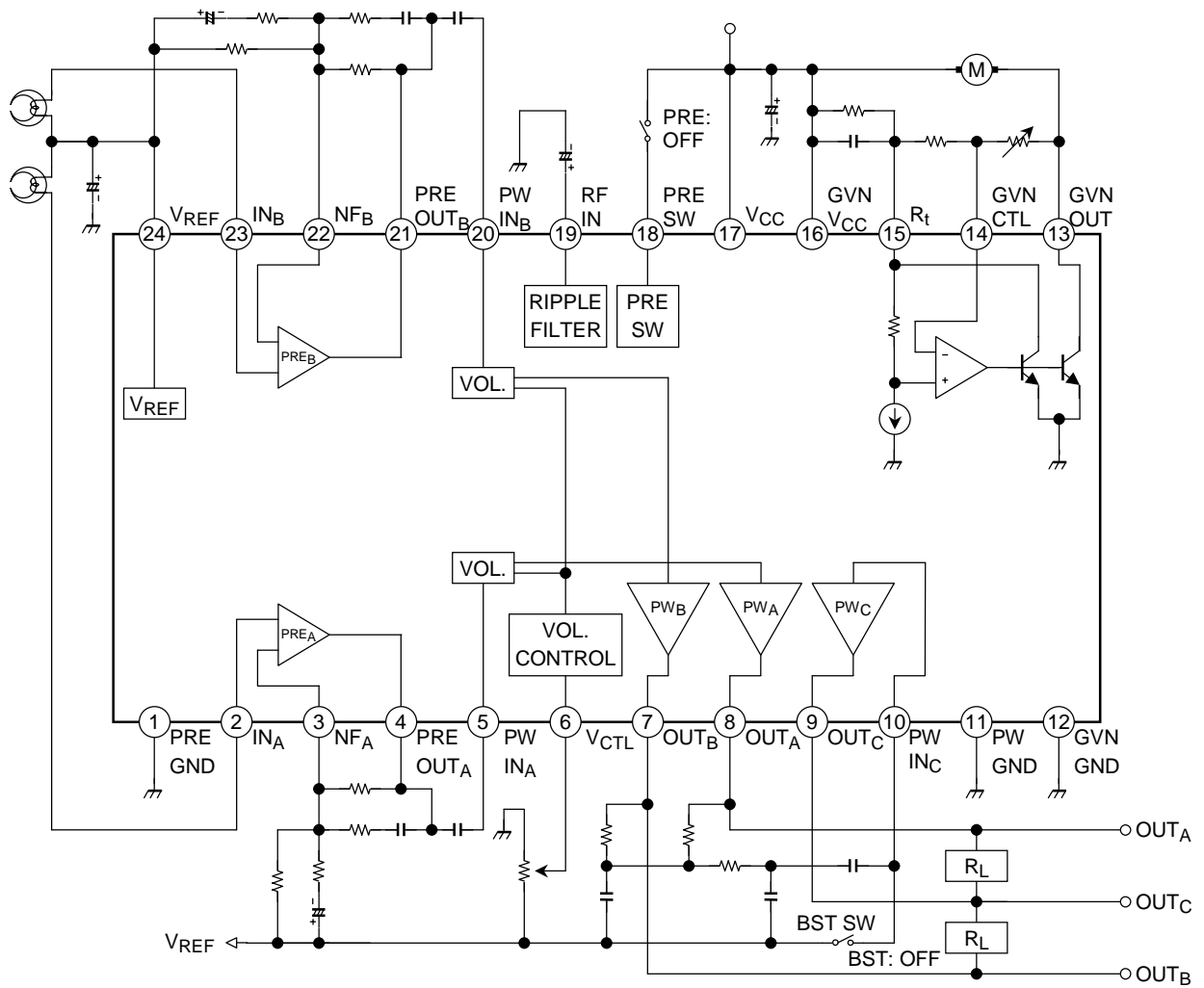

## Terminal Explanation (Terminal Voltage: Typical terminal voltage at no signal with test circuit, $V_{CC} = 3\text{ V}$ , $T_a = 25^\circ\text{C}$ )

Terminal		Function	Internal Circuit	Terminal Voltage (v)	
No.	Name				
1	PRE GND	The GND, except for power drive stage and motor governor stage.	—	0	
2	IN <sub>A</sub>	Input of preamplifier		1.2	
23	IN <sub>B</sub>			1.2	
3	NFA	NF of preamplifier		1.2	
22	NFB			1.2	
4	PRE OUT <sub>A</sub>	Output of preamplifier		1.2	
21	PRE OUT <sub>B</sub>				1.2
7	OUT <sub>B</sub>	Output of power amplifier		1.2	
8	OUT <sub>A</sub>				1.2
9	OUT <sub>C</sub>				1.2
5	PW IN <sub>A</sub>	Input of power amplifier		1.2	
20	PW IN <sub>B</sub>				1.2
6	V <sub>CTL</sub>	The terminal of DC volume control		—	

Terminal		Function	Internal Circuit	Terminal Voltage (v)
No.	Name			
10	PW INC	Input of center amplifier		1.2
11	PW GND	GND for power drive stage	—	0
12	GVN GND	GND for motor governor stage	—	0
13	GVN OUT	Motor terminal		—
14	GVN CTL	The terminal of motor speed control		—
15	Rt	The terminal of amateur compensation resistor		—
16	GVN VCC	VCC for motor governor stage		3
17	VCC	VCC for preamplifier stage and power amplifier stage.	—	3
18	PRE SW	Muting switch of preamplifier Preamp. on: "L" level/open Preamp. off: "H" level Refer to application note		—

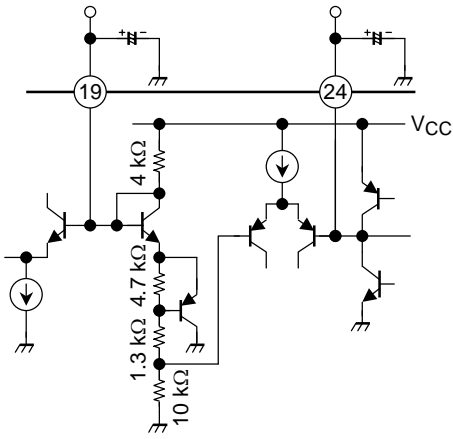
Terminal		Function	Internal Circuit	Terminal Voltage (v)
No.	Name			
19	RF IN	Ripple filter of power supply		2.5
24	V <sub>REF</sub>	Reference voltage Preamplifier and power amplifier operate on this reference.		1.2

## Application Note

- VCC and GND
 

This IC has two VCC terminals and three GND terminals. Pattern layout should be designed carefully to reduce the common impedance.

  - VCC
    - VCC (pin 17) ----- Preamplifier stage and power amplifier stage.
    - GVN VCC (pin 16) ----- Motor governor stage.
  - GND
    - PRE GND (pin 1) ----- Preamplifier stage, and power amplifier stage except for the power drive stage.
    - PW GND (pin 11) ----- Power drive stage of power amplifier.
    - GVN GND (pin 12) ----- Motor governor stage.
- VREF
 

It is necessary to stabilize the VREF circuit, because the internal circuit operate on this reference.
- RF IN
 

As this terminal is an input terminal of the ripple filter, it cannot supply a power supply to other ICs etc.
- Preamplifier
 

Input signal should be applied to VREF standard, otherwise pop noise become bigger when VCC is turned on and off.
- Power amplifier
 

It is necessary to insert the coupling capacitor through the PW IN terminal. In case that DC current or DC voltage is applied to the PW IN terminal, the internal circuit has unbalance and the power amplifier doesn' t operate normally.
- Operating supply voltage range of motor governor stage
 

As for the minimum of operating supply voltage range, the motor voltage is 1.8 V.  
In case that it is more than 1.8 V, the low voltage performance becomes bad.
- PRE SW sensitivity (Ta = 25°C)

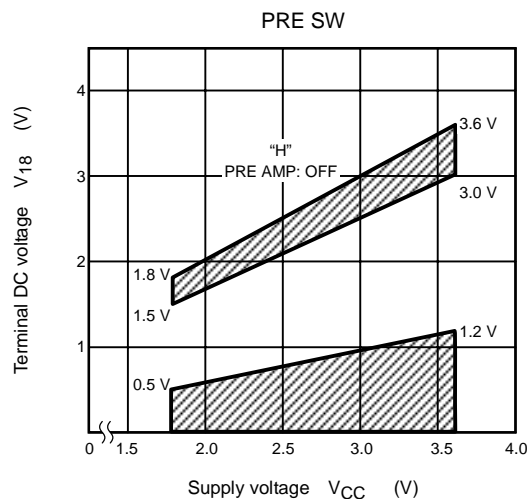

## Maximum Ratings (Ta = 25°C)

Characteristic	Symbol	Rating	Unit	
Supply voltage	V <sub>CC</sub>	4	V	
Power dissipation	P <sub>D</sub>	(Note 1)	400	mW
		(Note 2)	925	
Output current (PW AMP.)	I <sub>O</sub> (PW)	200	mA	
Output current (GVN)	I <sub>O</sub> (GVN)	700	mA	
Operating temperature	T <sub>opr</sub>	-25~75	°C	
Storage temperature	T <sub>stg</sub>	-55~150	°C	

Note 1: IC only: Derated above Ta = 25°C in the proportion 3.2 mW/°C

Note 2: IC + PCB (TOSHIBA typical PCB): Derated above Ta = 25°C in the proportion 7.4 mW/°C

## Electrical Characteristics

(Unless otherwise specified,  $V_{CC} = 3\text{ V}$ ,  $T_a = 25^\circ\text{C}$ ,  $f = 1\text{ kHz}$ , SW2: a, SW5: OPEN)

Preamplifier:  $R_g = 2.2\text{ k}\Omega$ ,  $R_L = 10\text{ k}\Omega$ , SW1: ON, SW3: b, SW4: b

Power amplifier:  $R_g = 600\ \Omega$ ,  $R_L = 16\ \Omega$ , Vol.: max, SW1: OPEN, SW3: a, SW4: a

Motor governor:  $I_m = 100\text{ mA}$ , SW1: OPEN, SW3: b, SW4: b)

	Characteristic	Symbol	Test circuit	Test condition	Min	Typ.	Max	Unit
	Quiescent supply current	$I_{CCQ1}$	—	Pre off, $V_{in} = 0$ , Vol.: min, SW4: b, SW5: ON	—	7.5	13	mA
		$I_{CCQ2}$	—	$V_{in} = 0$ , Vol.: min, SW4: b	—	8.5	14.5	
Pre amp.	Open loop voltage gain	$G_{VO}$	—	$V_o = -10\text{dBV}$ , SW2: b	—	86	—	dB
	Closed loop voltage gain	$G_{VC}$	—	$V_o = -10\text{dBV}$	—	35	—	dB
	Maximum output voltage	$V_{om}$	—	THD = 1%	550	720	—	mVrms
	Total harmonic distortion	THD1	—	$V_o = -10\text{dBV}$	—	0.02	0.3	%
	Equivalent input noise voltage	$V_{ni}$	—	$R_g = 2.2\text{ k}\Omega$ , SW1: OPEN BPF = 20 Hz~20 kHz, NAB ( $G_v = 35\text{dB}$ , $f = 1\text{ kHz}$ )	—	1.2	2.4	$\mu\text{Vrms}$
	Cross talk	CT1	—	$V_o = -10\text{dBV}$	—	70	—	dB
	Ripple rejection ratio	RR1	—	$f_r = 100\text{ Hz}$ , $V_r = -20\text{dBV}$	—	48	—	dB
	Preamplifier muting attenuation	ATT1	—	$V_o = -10\text{dBV}$ , SW5: OPEN → ON	—	80	—	dB
	Preamplifier on voltage	$V_{18}(\text{ON})$	—	$V_{CC} = 1.8\text{ V}$	0	—	0.5	V
	Preamplifier off voltage	$V_{18}(\text{OFF})$	—		1.5	—	1.8	V
Power amp.	Voltage gain	$G_V$	—	$V_o = -10\text{dBV}$	29	31	33	dB
	Channel balance	CB	—	$V_o = -10\text{dBV}$	-1.5	0	+1.5	dB
	Output power 1	$P_{o1}$	—	$R_L = 16\ \Omega$ , THD = 10%	17	28	—	mW
	Output power 2	$P_{o2}$	—	$R_L = 32\ \Omega$ , THD = 10%	—	20	—	mW
	Total harmonic distortion	THD2	—	$P_o = 1\text{ mW}$	—	0.5	—	%
	Output noise voltage	$V_{no}$	—	$R_g = 600\ \Omega$ , SW3: b BPF = 20 Hz~20 kHz	—	270	400	$\mu\text{Vrms}$
	Ripple rejection ratio	RR2	—	$f_r = 100\text{ Hz}$ , $V_r = -20\text{dBV}$	—	52	—	dB
	Cross talk	CT2	—	$V_o = -10\text{dBV}$	—	32	—	dB
	Dc volume maximum attenuation	ATT2	—	$V_o = -10\text{dBV}$ , SW4: a→b (Vol.: max → min)	—	82	—	dB
Motor governor	Supply current	$I_{CC}$	—	$I_m = 0$	—	2.5	3.5	mA
	Saturation voltage	$V_{CE}(\text{sat})$	—	$I_m = 200\text{ mA}$	—	—	0.5	V
	Reference voltage	$\Delta V_{REF}$	—	$I_m = 100\text{ mA}$	0.76	0.81	0.86	V
	Reference voltage fluctuation 1	$\Delta V_{REF1}$	—	$V_{CC} = 2.1\sim 3.6\text{ V}$	—	0.25	—	%/V
	Reference voltage fluctuation 2	$\Delta V_{REF2}$	—	$I_m = 25\sim 250\text{ mA}$	—	0.003	—	%/mA
	Reference voltage fluctuation 3	$\Delta V_{REF3}$	—	$T_a = -25\sim 75^\circ\text{C}$	—	0.005	—	%/°C
	Current ratio	K	—	—	34.5	37.5	40.5	
	Current ratio fluctuation 1	$\Delta K1$	—	$V_{CC} = 2.1\sim 3.6\text{ V}$	—	0.25	—	%/V
	Current ratio fluctuation 2	$\Delta K2$	—	$I_m = 25\sim 250\text{ mA}$	—	0.08	—	%/mA
	Current ratio fluctuation 3	$\Delta K3$	—	$T_a = -25\sim 75^\circ\text{C}$	—	0.005	—	%/°C



## Test Circuit

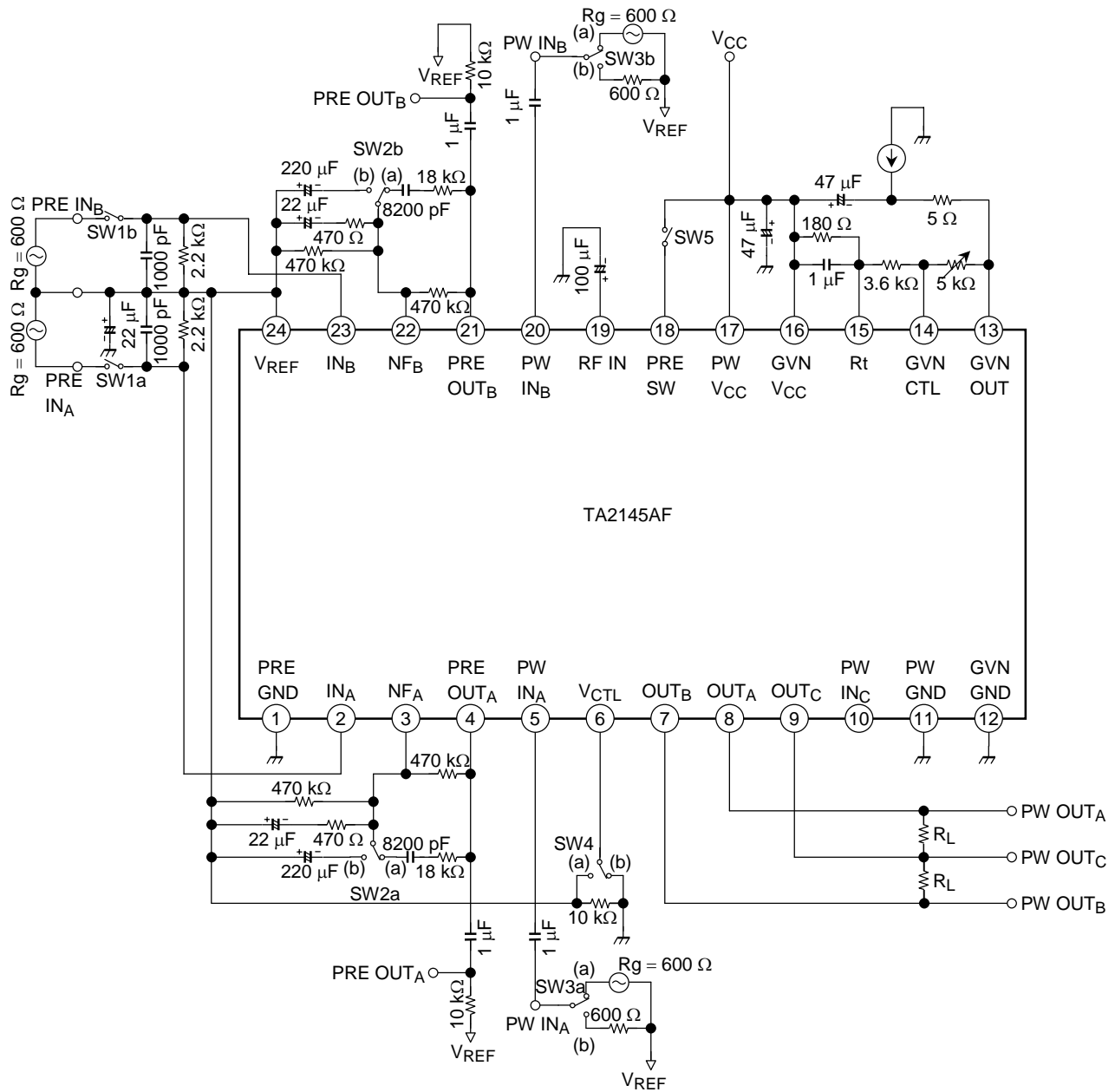

**Characteristic Curves (Unless otherwise specified,  $V_{CC} = 3\text{ V}$ ,  $T_a = 25^\circ\text{C}$ ,  $f = 1\text{ kHz}$ ,  
**Preamplifier:**  $R_g = 2.2\text{ k}\Omega$ ,  $R_L = 10\text{ k}\Omega$   
**Power amplifier:**  $R_g = 600\ \Omega$ ,  $R_L = 16\ \Omega$ , Vol. = max  
**Motor governor:**  $I_m = 100\text{ mA}$ )**

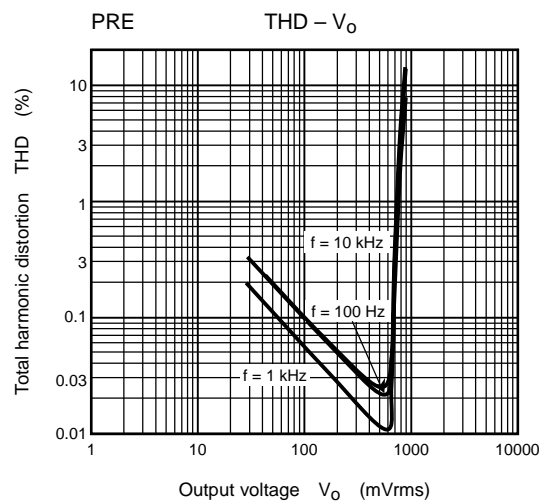
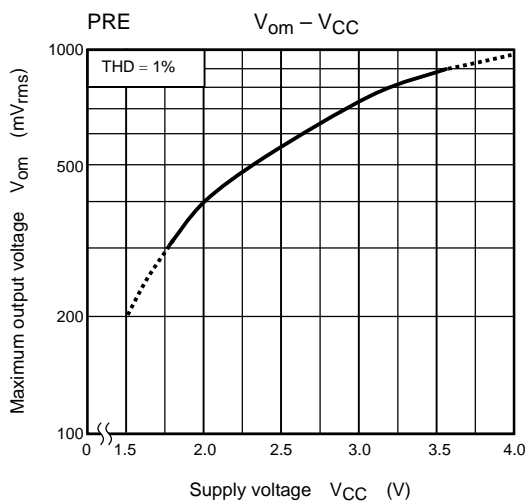
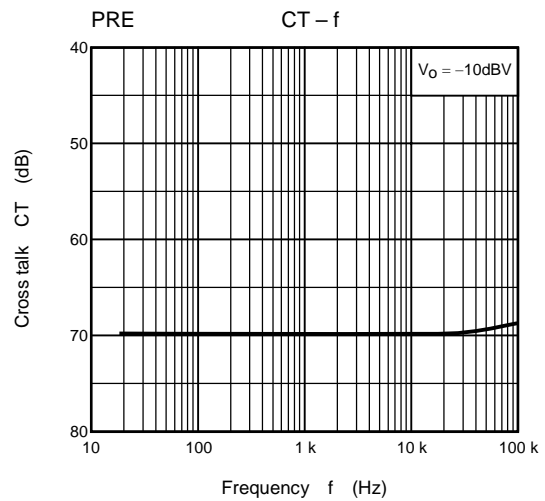
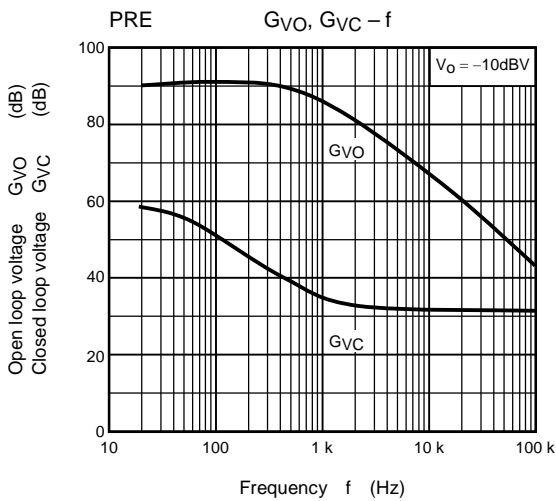
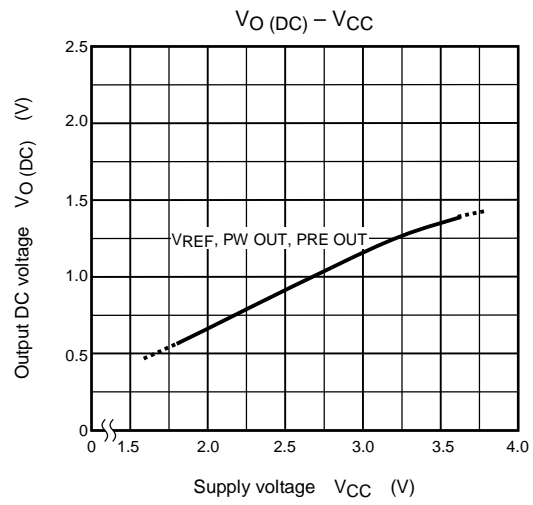
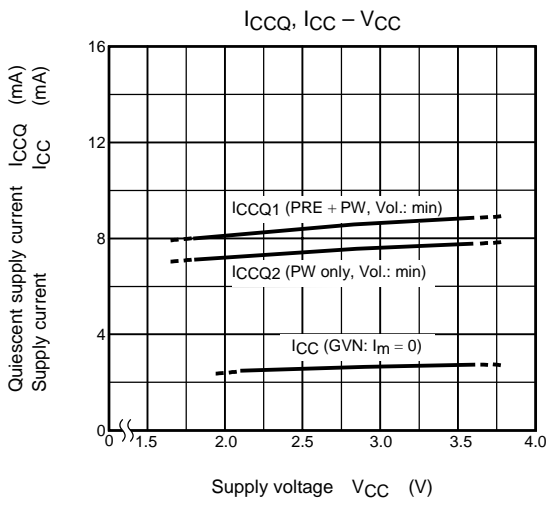

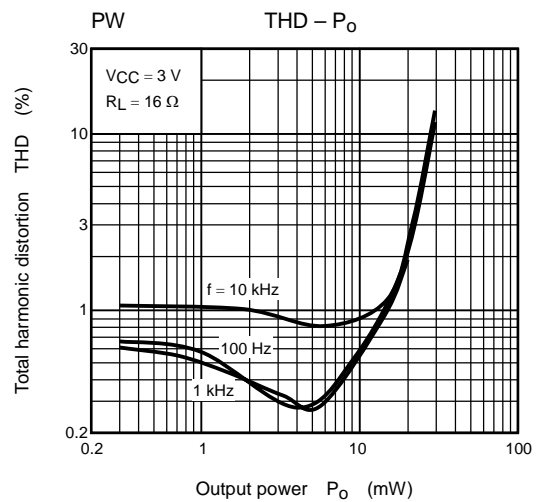
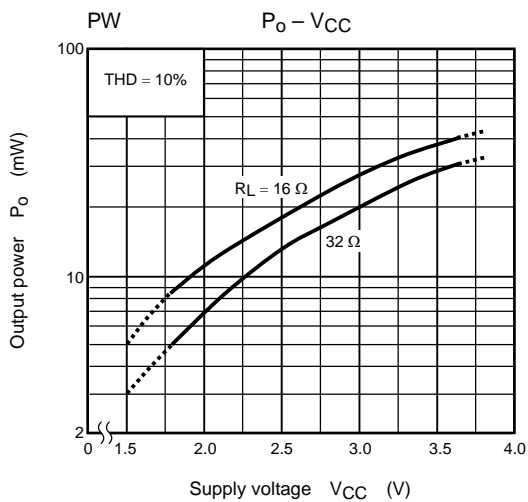
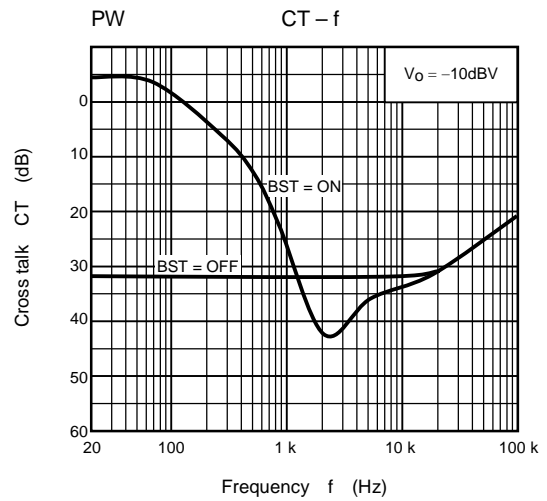
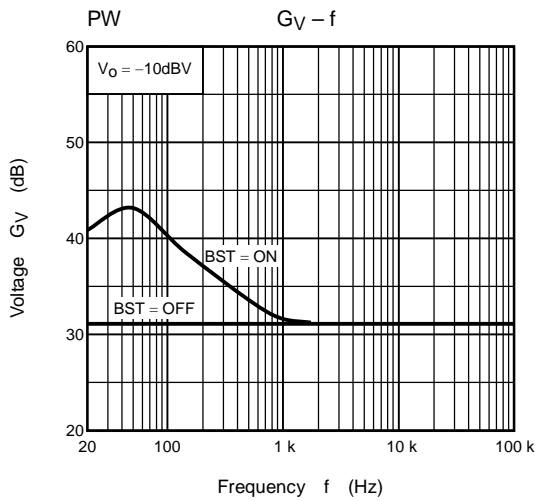
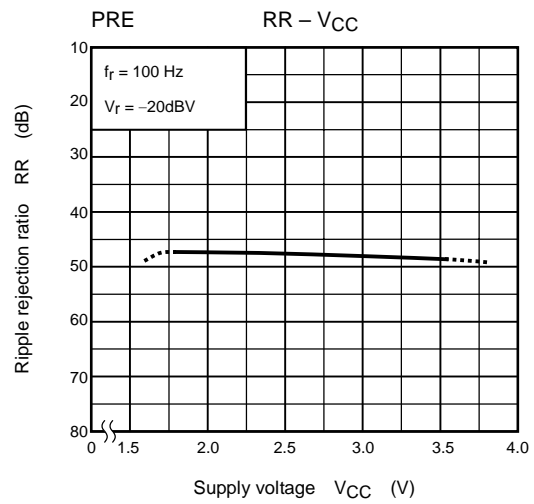
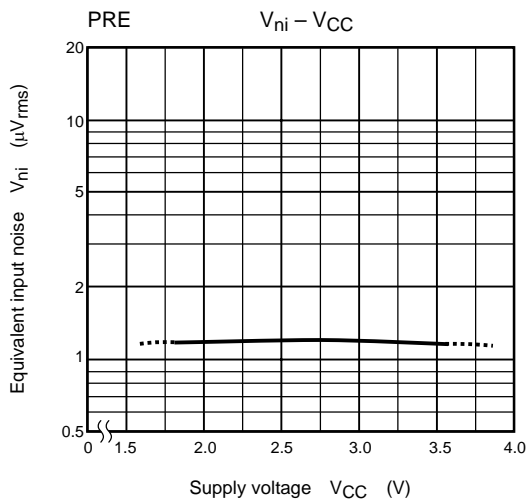

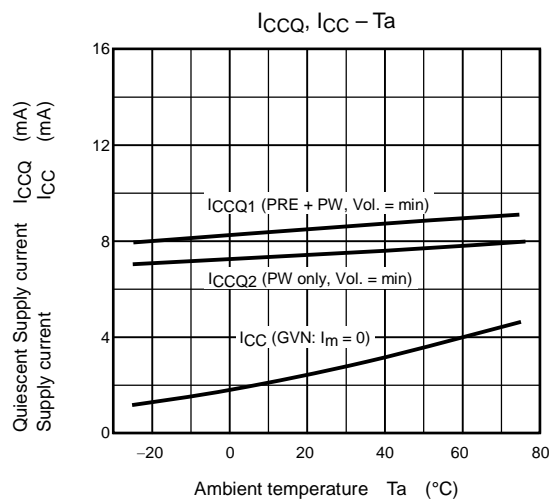
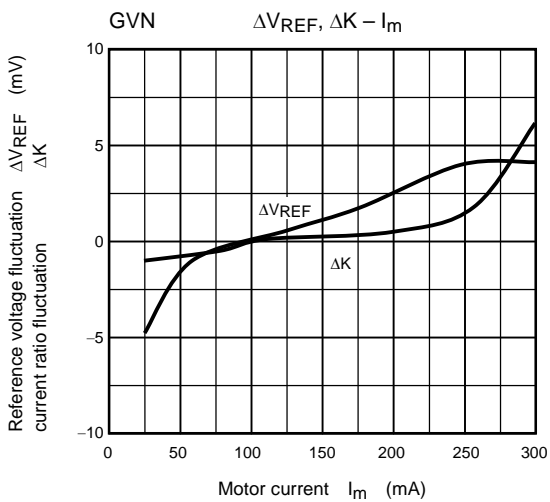
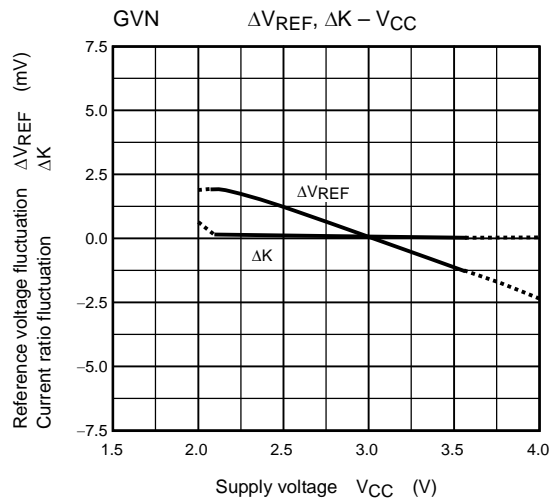
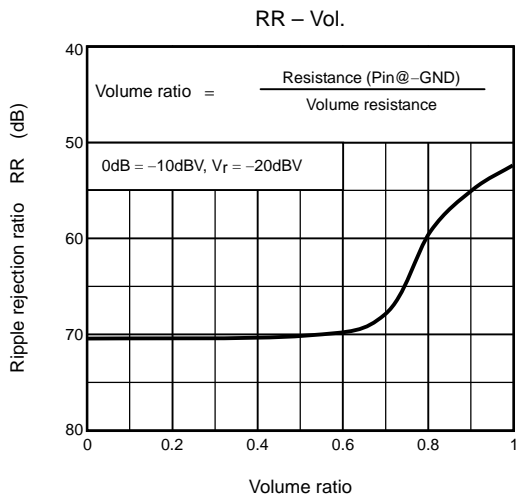
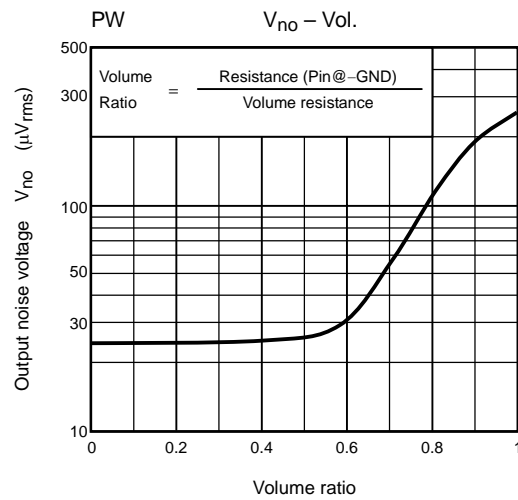
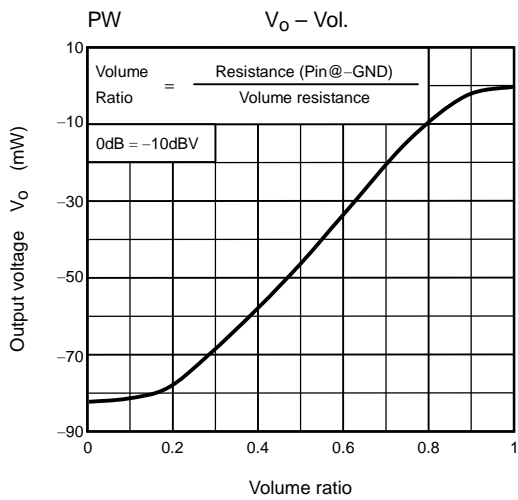

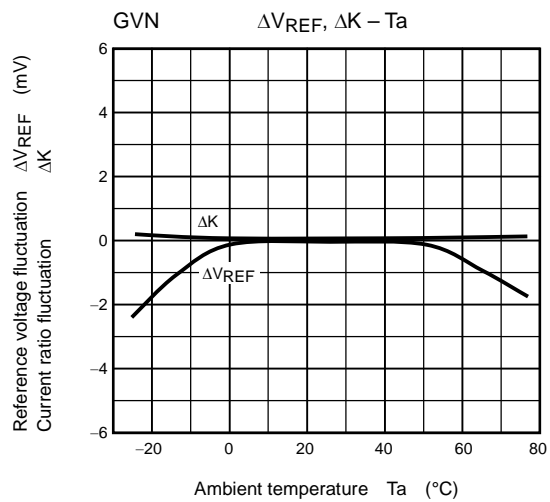
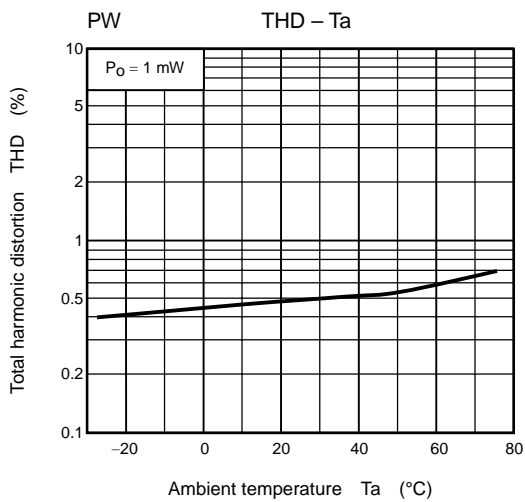
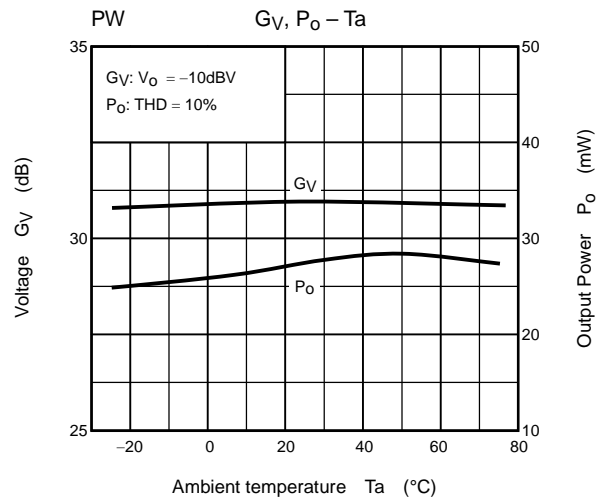
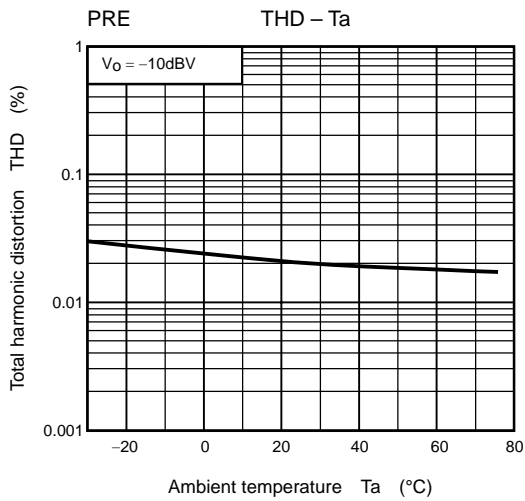
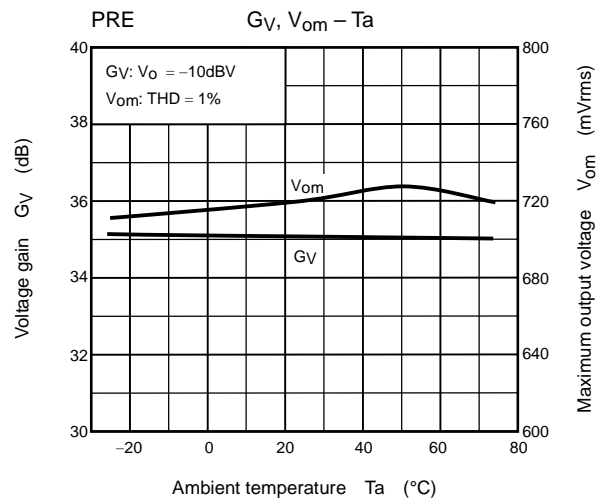
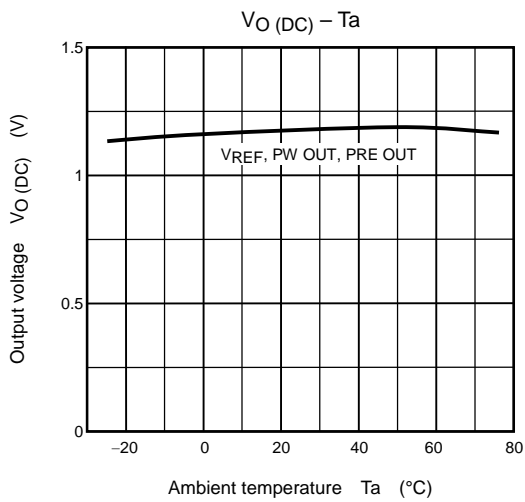

## Application Circuit

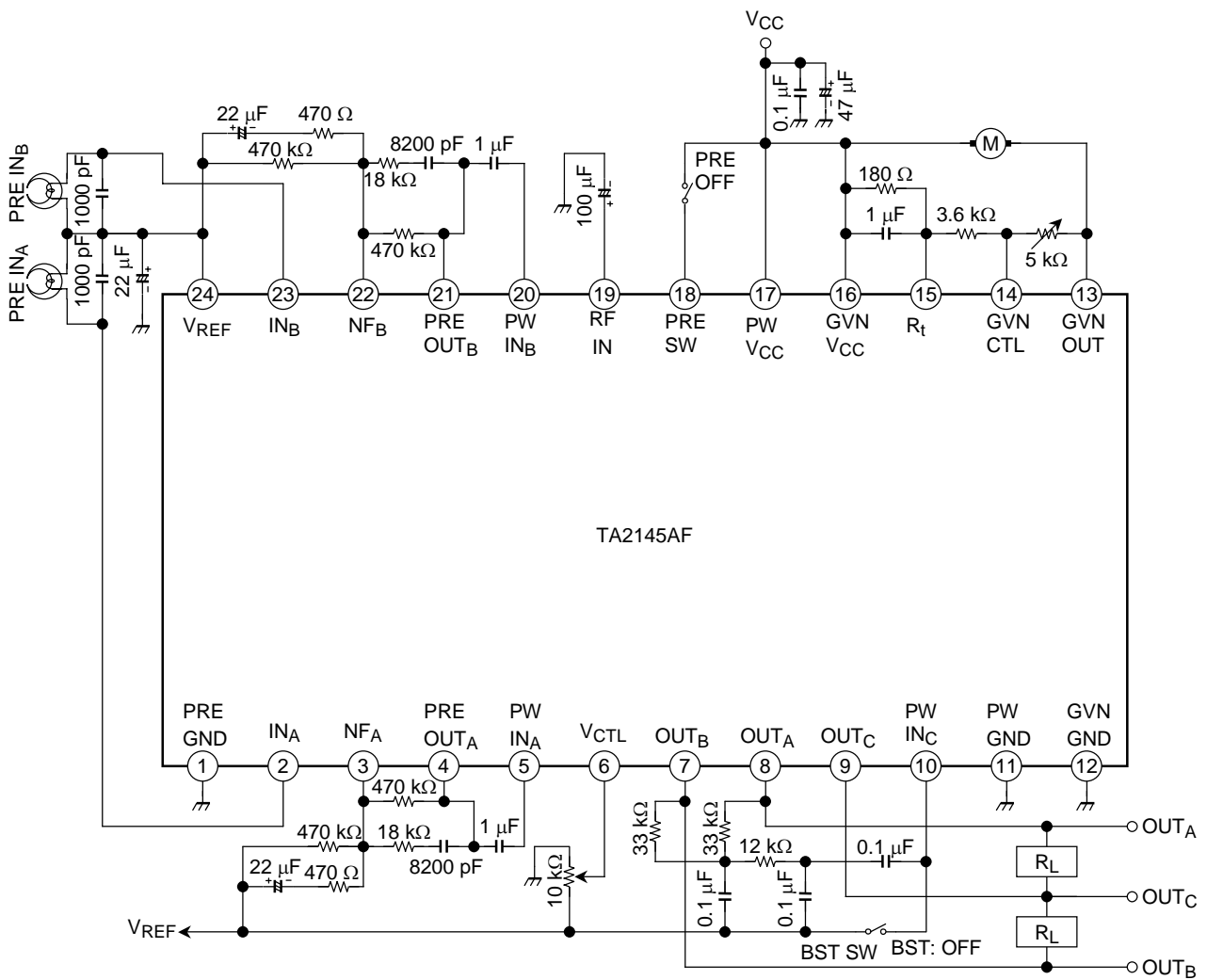

**Package Dimensions**

SSOP24-P-300-1.00

Unit : mm

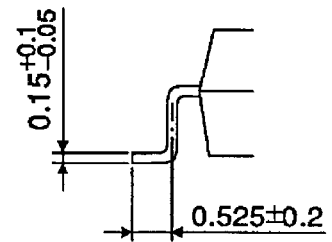
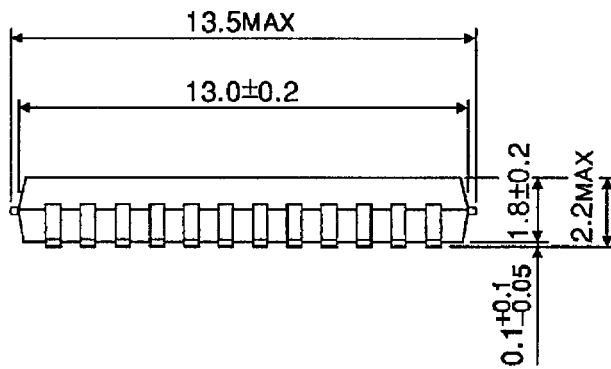
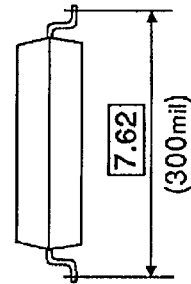
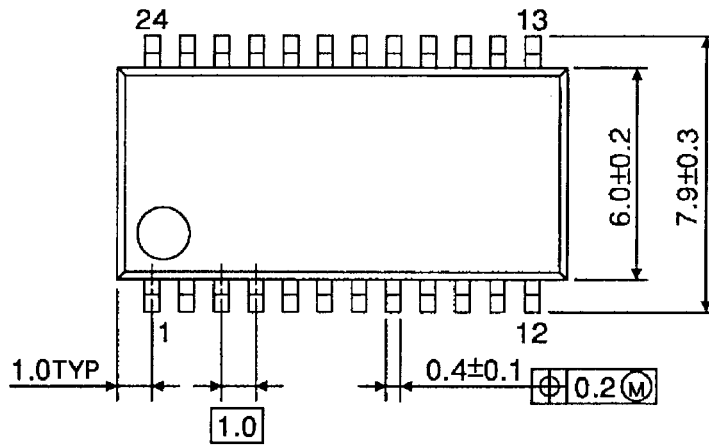

Weight: 0.32 g (typ.)

**RESTRICTIONS ON PRODUCT USE**

000707EBA

- TOSHIBA is continually working to improve the quality and reliability of its products. Nevertheless, semiconductor devices in general can malfunction or fail due to their inherent electrical sensitivity and vulnerability to physical stress. It is the responsibility of the buyer, when utilizing TOSHIBA products, to comply with the standards of safety in making a safe design for the entire system, and to avoid situations in which a malfunction or failure of such TOSHIBA products could cause loss of human life, bodily injury or damage to property.  
In developing your designs, please ensure that TOSHIBA products are used within specified operating ranges as set forth in the most recent TOSHIBA products specifications. Also, please keep in mind the precautions and conditions set forth in the "Handling Guide for Semiconductor Devices," or "TOSHIBA Semiconductor Reliability Handbook" etc..
- The TOSHIBA products listed in this document are intended for usage in general electronics applications (computer, personal equipment, office equipment, measuring equipment, industrial robotics, domestic appliances, etc.). These TOSHIBA products are neither intended nor warranted for usage in equipment that requires extraordinarily high quality and/or reliability or a malfunction or failure of which may cause loss of human life or bodily injury ("Unintended Usage"). Unintended Usage include atomic energy control instruments, airplane or spaceship instruments, transportation instruments, traffic signal instruments, combustion control instruments, medical instruments, all types of safety devices, etc.. Unintended Usage of TOSHIBA products listed in this document shall be made at the customer's own risk.
- The products described in this document are subject to the foreign exchange and foreign trade laws.
- The information contained herein is presented only as a guide for the applications of our products. No responsibility is assumed by TOSHIBA CORPORATION for any infringements of intellectual property or other rights of the third parties which may result from its use. No license is granted by implication or otherwise under any intellectual property or other rights of TOSHIBA CORPORATION or others.
- The information contained herein is subject to change without notice.



This datasheet has been download from:

[www.datasheetcatalog.com](http://www.datasheetcatalog.com)

Datasheets for electronics components.