

TOSHIBA BIPOLAR LINEAR INTEGRATED CIRCUIT SILICON MONOLITHIC

TA2145F**3 V STEREO HEADPHONE AMPLIFIER (3 V USE)**

The TA2145F is developed for play-back stereo headphone equipments (3 V USE).

It is built in dual preamplifiers, dual OCL power amplifiers, motor governor, DC volume control and preamplifier on/off switch etc.

FEATURES

- Built-in preamplifier
 - Input coupling condenser-less
 - Built-in input capacitor for reducing buzz noise
 - Low noise : $V_{ni} = 1.2 \mu V_{rms}$ (Typ.)
 - Preamplifier on/off switch.
- Built-in power amplifier
 - OCL (Output condenser-less)
 - Voltage gain : $G_V = 31$ dB (Typ.)
- Built-in motor governor
 - Current proportion type
- Built-in DC volume control function
 - DC volume maximum attenuation : $ATT = 82$ dB ($T_a = 25^\circ C$, Typ.)
- Built-in bass boost function
- Low supply current ($V_{CC} = 3$ V, $T_a = 25^\circ C$, Typ.)
 - PRE + PW ($f = 1$ kHz, PRE OUT = 100 mV_{rms})

	No Signal (Vol : MIN.)	Output Power	
		0.1 mW × 2	0.5 mW × 2
$R_L = 16 \Omega$	8.5 mA	10.5 mA	16.5 mA
$R_L = 32 \Omega$	8.5 mA	9.8 mA	14 mA

GVN : $I_{CC} = 2.5$ mA

- Operating supply voltage range ($T_a = 25^\circ C$)
 - PRE + PW : $V_{CC(opr)} = 1.8 \sim 3.6$ V
 - GVN : $V_{CC(opr)} = 2.1 \sim 3.6$ V (Motor voltage = 1.8 V)

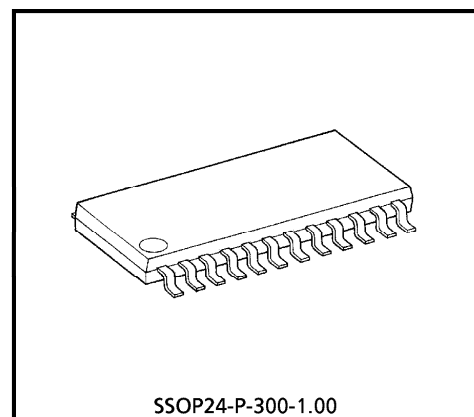

SSOP24-P-300-1.00
Weight : 0.32 g (Typ.)

980910EBA1

- TOSHIBA is continually working to improve the quality and the reliability of its products. Nevertheless, semiconductor devices in general can malfunction or fail due to their inherent electrical sensitivity and vulnerability to physical stress. It is the responsibility of the buyer, when utilizing TOSHIBA products, to observe standards of safety, and to avoid situations in which a malfunction or failure of a TOSHIBA product could cause loss of human life, bodily injury or damage to property. In developing your designs, please ensure that TOSHIBA products are used within specified operating ranges as set forth in the most recent products specifications. Also, please keep in mind the precautions and conditions set forth in the TOSHIBA Semiconductor Reliability Handbook.
- The products described in this document are subject to the foreign exchange and foreign trade laws.
- The information contained herein is presented only as a guide for the applications of our products. No responsibility is assumed by TOSHIBA CORPORATION for any infringements of intellectual property or other rights of the third parties which may result from its use. No license is granted by implication or otherwise under any intellectual property or other rights of TOSHIBA CORPORATION or others.
- The information contained herein is subject to change without notice.

BLOCK DIAGRAM

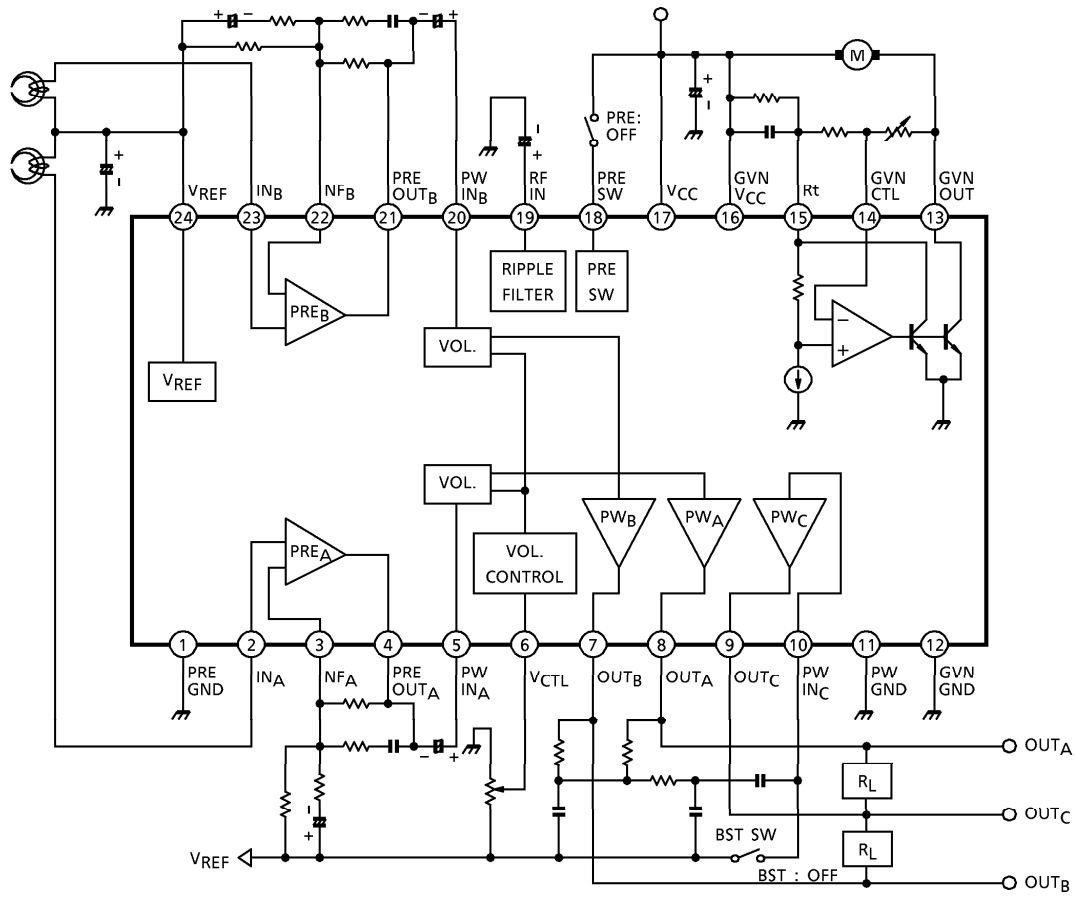

TERMINAL EXPLANATION

TERMINAL VOLTAGE : Typical terminal voltage at no signal with test circuit ($V_{CC} = 3V$, $T_a = 25^\circ C$)

TERMINAL		FUNCTION	INTERNAL CIRCUIT	TERMINAL VOLTAGE (V)
No.	NAME			
1	PRE GND	The GND, except for power drive stage and motor governor stage.	—	0
2	IN _A	Input of preamplifier		1.2
23	IN _B			1.2
3	NFA			NF of preamplifier
22	NFB			
4	PRE OUT _A	Output of preamplifier		1.2
21	PRE OUT _B			
7	OUT _B			
8	OUT _A	Output of power amplifier		
9	OUT _C			
5	PW IN _A	Input of power amplifier		1.2
20	PW IN _B			
6	VCTL	The terminal of DC volume control		—

TERMINAL		FUNCTION	INTERNAL CIRCUIT	TERMINAL VOLTAGE (V)
No.	NAME			
10	PW INC	Input of center amplifier		1.2
11	PW GND	GND for power drive stage	—	0
12	GVN GND	GND for motor governor stage	—	0
13	GVN OUT	Motor terminal		—
14	GVN CTL	The terminal of motor speed control		—
15	Rt	The terminal of amateur compensation resistor		—
16	GVN VCC	VCC for motor governor stage		3
17	VCC	VCC for preamplifier stage and power amplifier stage.	—	3
18	PRE SW	Muting switch of preamplifier (Preamp. on : "L" level / open Preamp. off : "H" level Refer to application note		—

TERMINAL		FUNCTION	INTERNAL CIRCUIT	TERMINAL VOLTAGE (V)
No.	NAME			
19	RF IN	Ripple filter of power supply		2.5
24	VREF	Reference voltage ● Preamplifier and power amplifier operate on this reference.		1.2

APPLICATION NOTE1. V_{CC} and GND

This IC has two V_{CC} terminals and three GND terminals. Pattern layout should be designed carefully to reduce the common impedance.

 V_{CC}

V_{CC} (pin 17) : Preamplifier stage and power amplifier stage.

GVN V_{CC} (pin 16) : Motor governor stage.

GND

PRE GND (pin 1) : Preamplifier stage, and power amplifier stage except for the power drive stage.

PW GND (pin 11) : Power drive stage of power amplifier.

GVN GND (pin 12) : Motor governor stage.

2. V_{REF}

It is necessary to stabilize the V_{REF} circuit, because the internal circuit operate on this reference.

3. RF IN

As this terminal is an input terminal of the ripple filter, it cannot supply a power supply to other ICs etc.

4. Preamplifier

Input signal should be applied to V_{REF} standard, otherwise pop noise become bigger when V_{CC} is turned on and off.

5. Power amplifier

It is necessary to insert the coupling capacitor through the PW IN terminal. In case that DC current or DC voltage is applied to the PW IN terminal, the internal circuit has unbalance and the power amplifier doesn't operate normally.

6. Operating supply voltage range of motor governor stage

As for the minimum of operating supply voltage range, the motor voltage is 1.8V.

In case that it is more than 1.8V, the low voltage performance becomes bad.

7. PRE SW sensitivity (Ta = 25°C)

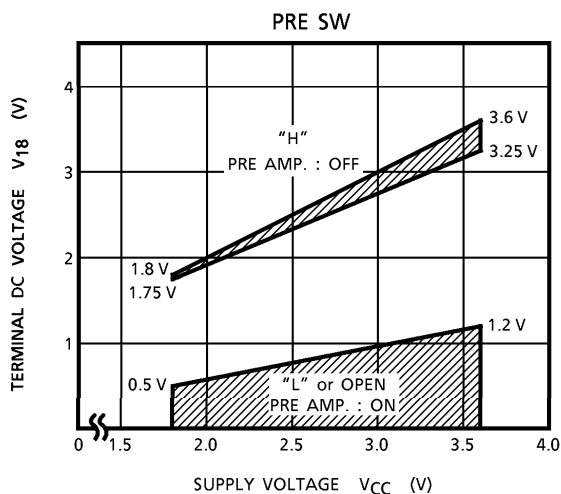

MAXIMUM RATINGS (Ta = 25°C)

CHARACTERISTIC	SYMBOL	RATING	UNIT
Supply Voltage	V _{CC}	4	V
Power Dissipation	P _D	Note 1	400
		Note 2	925
Output Current (PW AMP.)	I _O (PW)	200	mA
Output Current (GVN)	I _O (GVN)	700	mA
Operating Temperature	T _{opr}	- 25~75	°C
Storage Temperature	T _{stg}	- 55~150	°C

(Note 1) : IC only : Derated above Ta = 25°C in the proportion 3.2 mW/°C

(Note 2) : IC + PCB (TOSHIBA typical PCB) : Derated above Ta = 25°C in the proportion 7.4 mW/°C

ELECTRICAL CHARACTERISTICS

Unless otherwise specified, $V_{CC} = 3\text{ V}$, $T_a = 25^\circ\text{C}$, $f = 1\text{ kHz}$, SW2 : a, SW5 : OPEN

Preamplifier : $R_g = 2.2\text{ k}\Omega$, $R_L = 10\text{ k}\Omega$, SW1 : ON, SW3 : b, SW4 : b

Power amplifier : $R_g = 600\ \Omega$, $R_L = 16\ \Omega$, Vol : MAX, SW1 : OPEN, SW3 : a, SW4 : a

Motor governor : $I_m = 100\text{ mA}$, SW1 : OPEN, SW3 : b, SW4 : b

	CHARACTERISTIC	SYMBOL	TEST CIR-CUIT	TEST CONDITION	MIN.	TYP.	MAX.	UNIT
	Quiescent Supply Current 1	I_{CCQ1}	—	PRE OFF, $V_{in} = 0$, Vol : MIN, SW4 : b, SW5 : ON	—	7.5	13	mA
	Quiescent Supply Current 2	I_{CCQ2}	—	$V_{in} = 0$, Vol : MIN, SW4 : b	—	8.5	14.5	
PRE AMP.	Open Loop Voltage Gain	G_{VO}	—	$V_O = -10\text{ dBV}$, SW2 : b	—	86	—	dB
	Closed Loop Voltage Gain	G_{VC}	—	$V_O = -10\text{ dBV}$	—	35	—	dB
	Maximum Output Voltage	V_{om}	—	THD = 1%	550	720	—	mV _{rms}
	Total Harmonic Distortion	THD1	—	$V_O = -10\text{ dBV}$	—	0.02	0.3	%
	Equivalent Input Noise Voltage	V_{ni}	—	$R_g = 2.2\text{ k}\Omega$, SW1 : OPEN BPF = 20 Hz~20 kHz, NAB ($G_V = 35\text{ dB}$, $f = 1\text{ kHz}$)	—	1.2	2.4	μV_{rms}
	Cross Talk	CT1	—	$V_O = -10\text{ dBV}$	—	70	—	dB
	Ripple Rejection Ratio	RR1	—	$f_r = 100\text{ Hz}$, $V_r = -20\text{ dBV}$	—	48	—	dB
	Preamplifier Muting Attenuation	ATT1	—	$V_O = -10\text{ dBV}$ SW5 : OPEN → ON	—	80	—	dB
	Preamplifier On Voltage	$V_{18(OFF)}$	—	$V_{CC} = 1.8\text{ V}$	0	—	0.5	V
	Preamplifier Off Voltage	$V_{18(OFF)}$	—		1.75	—	1.8	V
POWER AMP.	Voltage Gain	G_V	—	$V_O = -10\text{ dBV}$	29	31	33	dB
	Channel Balance	CB	—		-1.5	0	+1.5	dB
	Output Power 1	P_{O1}	—	$R_L = 16\ \Omega$, THD = 10%	17	28	—	mW
	Output Power 2	P_{O2}	—	$R_L = 32\ \Omega$, THD = 10%	—	20	—	mW
	Total Harmonic Distortion	THD2	—	$P_O = 1\text{ mW}$	—	0.5	—	%
	Output Noise Voltage	V_{no}	—	$R_g = 600\ \Omega$, SW3 : b BPF = 20 Hz~20 kHz	—	270	400	μV_{rms}
	Ripple Rejection Ratio	RR2	—	$f_r = 100\text{ Hz}$, $V_r = -20\text{ dBV}$	—	52	—	dB
	Cross Talk	CT2	—	$V_O = -10\text{ dBV}$	—	32	—	dB
MOTOR GOVERNOR	DC Volume Maximum Attenuation	ATT2	—	$V_O = -10\text{ dBV}$ SW4 : a → b (Vol : MAX → MIN)	—	82	—	dB
	Supply Current	I_{CC}	—	$I_m = 0$	—	2.5	3.5	mA
	Saturation Voltage	$V_{CE(sat)}$	—	$I_m = 200\text{ mA}$	—	—	0.5	V
	Reference Voltage	V_{REF}	—	$I_m = 100\text{ mA}$	0.76	0.81	0.86	V
	Reference Voltage Fluctuation 1	ΔV_{REF1}	—	$V_{CC} = 2.1\sim 3.6\text{ V}$	—	0.25	—	% / V
	Reference Voltage Fluctuation 2	ΔV_{REF2}	—	$I_m = 25\sim 250\text{ mA}$	—	0.003	—	% / mA
	Reference Voltage Fluctuation 3	ΔV_{REF3}	—	$T_a = -25\sim 75^\circ\text{C}$	—	0.005	—	% / °C
	Current Ratio	K	—		34.5	37.5	40.5	
	Current Ratio Fluctuation 1	$\Delta K1$	—	$V_{CC} = 2.1\sim 3.6\text{ V}$	—	0.25	—	% / V
	Current Ratio Fluctuation 2	$\Delta K2$	—	$I_m = 25\sim 250\text{ mA}$	—	0.08	—	% / mA
	Current Ratio Fluctuation 3	$\Delta K3$	—	$T_a = -25\sim 75^\circ\text{C}$	—	0.005	—	% / °C

TEST CIRCUIT

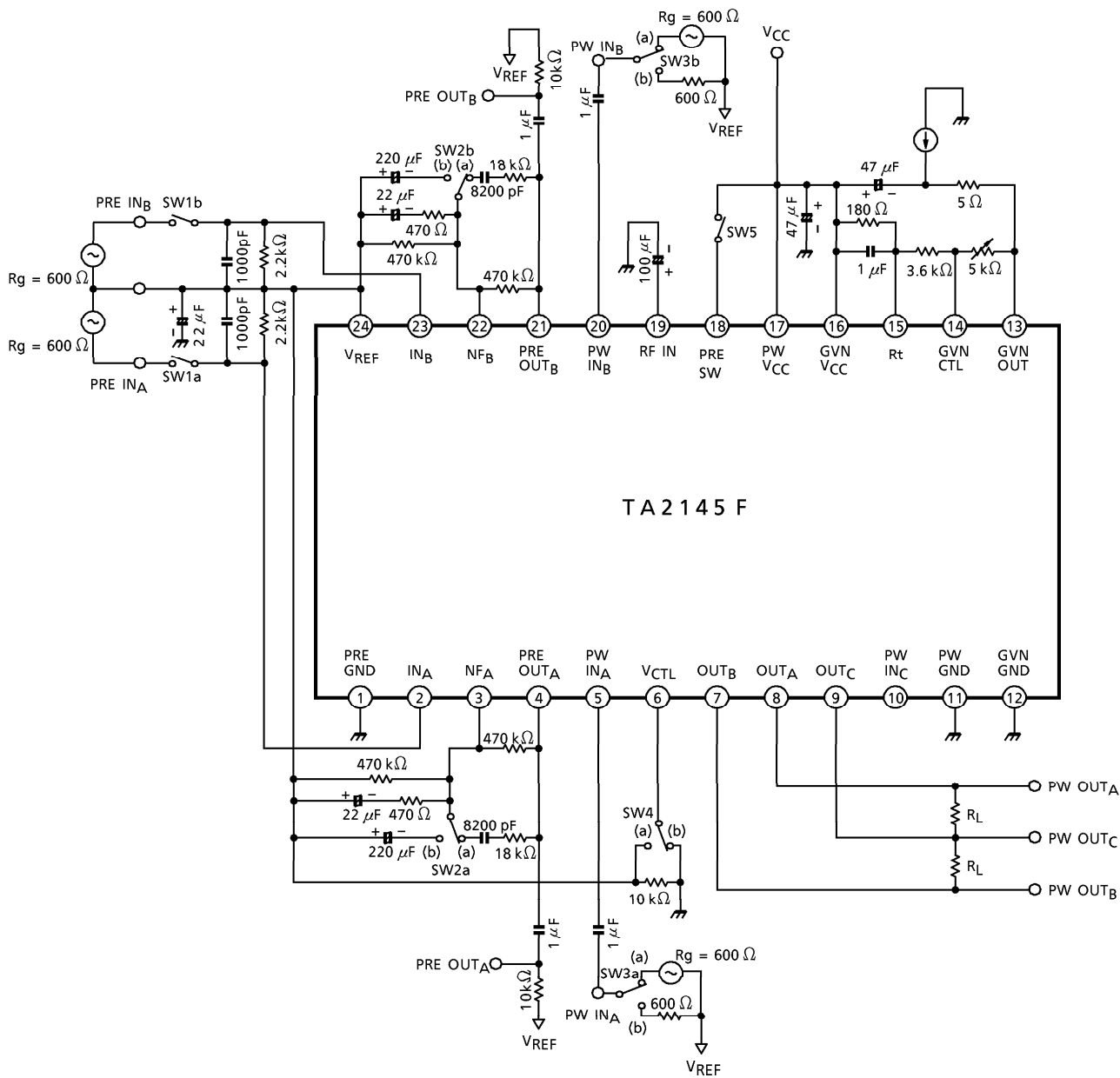

CHARACTERISTIC CURVES

Unless otherwise specified $V_{CC} = 3\text{ V}$, $T_a = 25^\circ\text{C}$, $f = 1\text{ kHz}$
 Preamplifier : $R_g = 2.2\text{ k}\Omega$, $R_L = 10\text{ k}\Omega$
 Power amplifier : $R_g = 600\ \Omega$, $R_L = 16\ \Omega$, $V_{ol} = \text{MAX.}$
 Motor governor : $I_m = 100\text{ mA}$

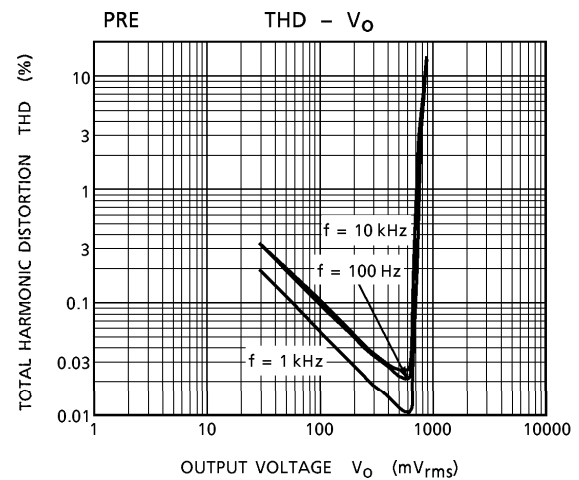
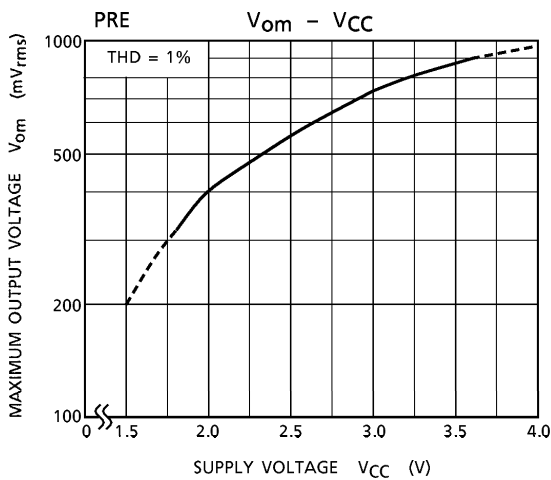
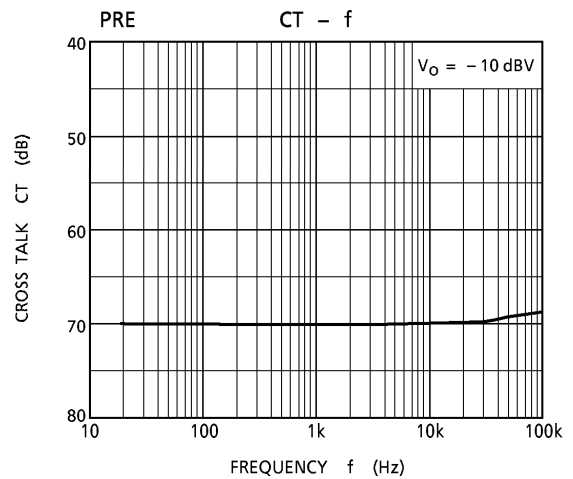
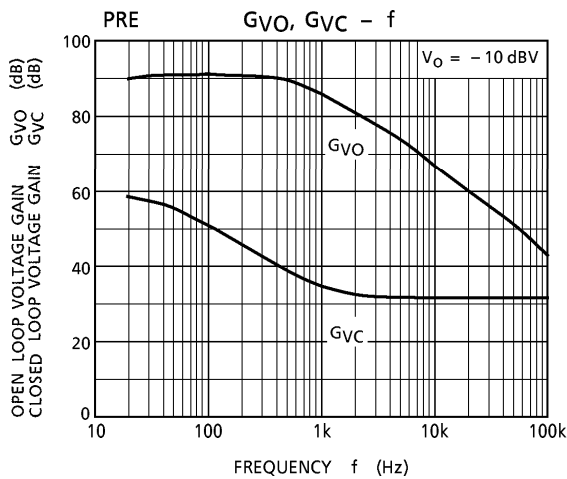
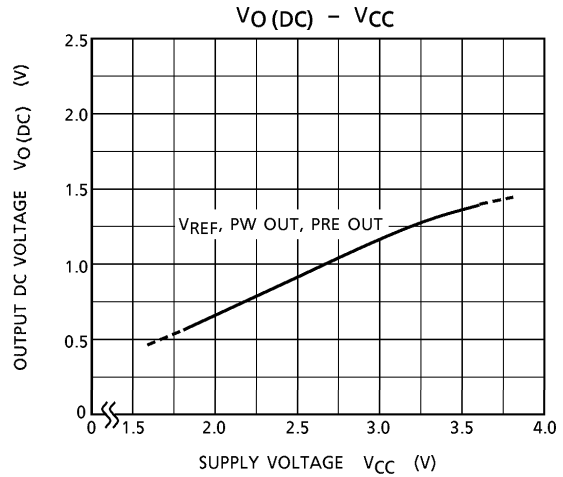
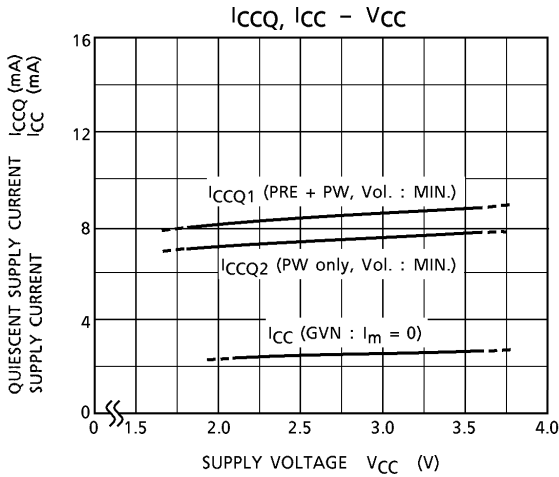

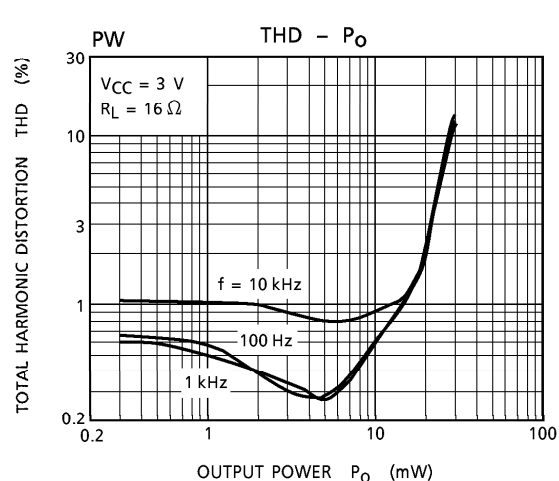
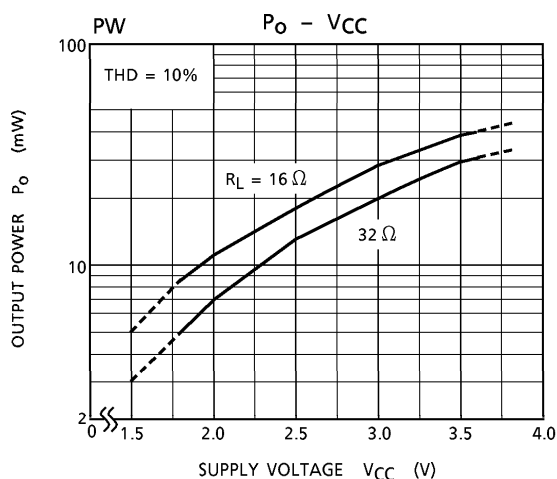
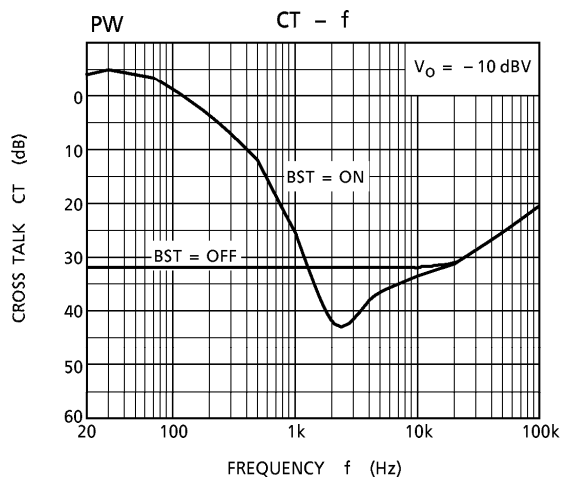
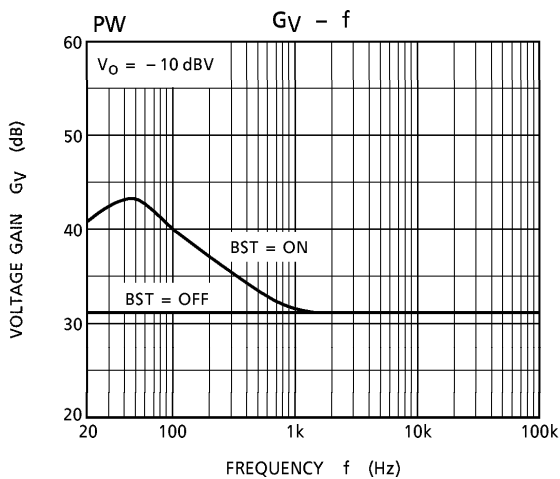
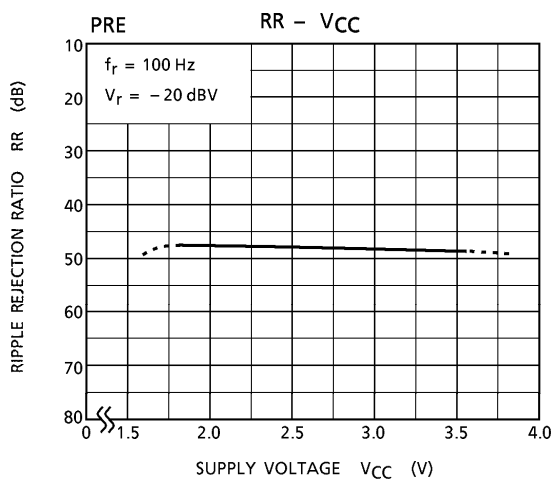
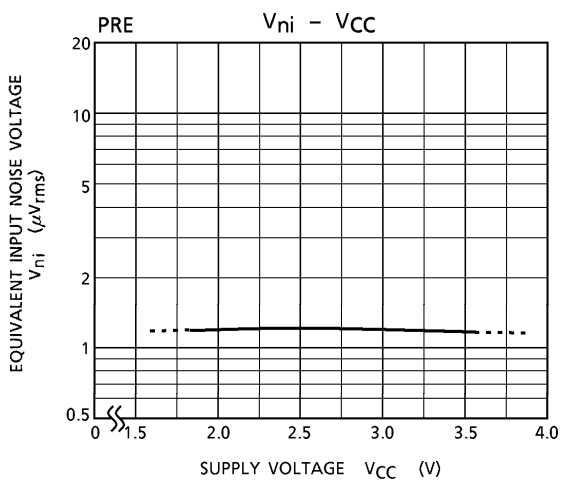

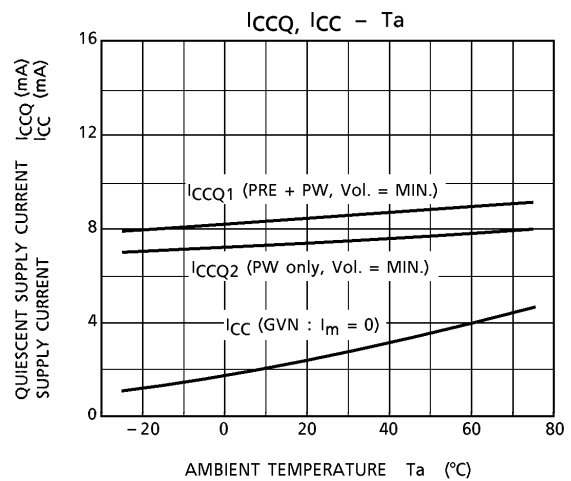
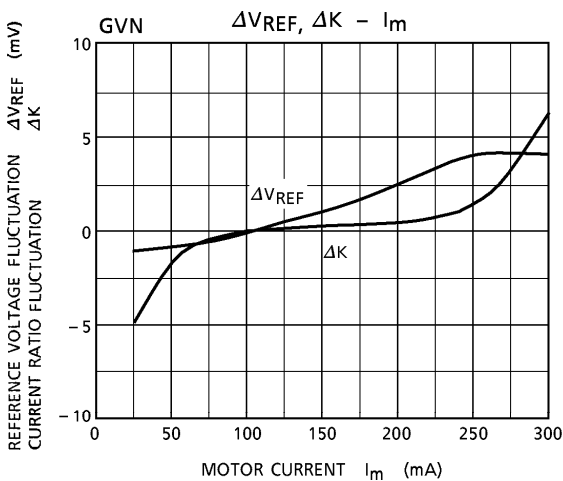
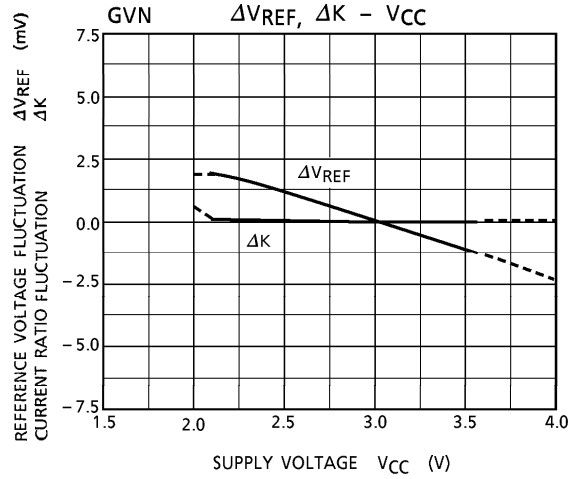
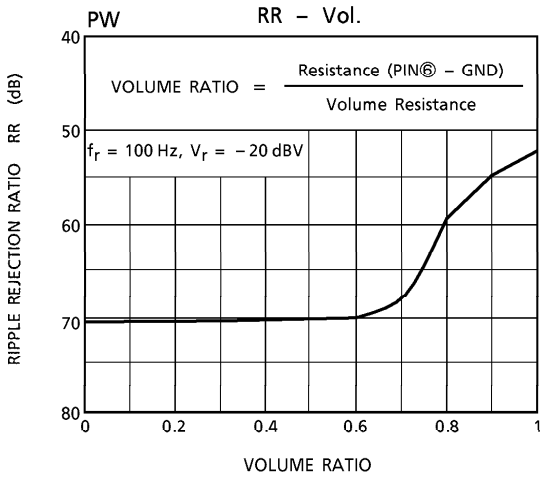
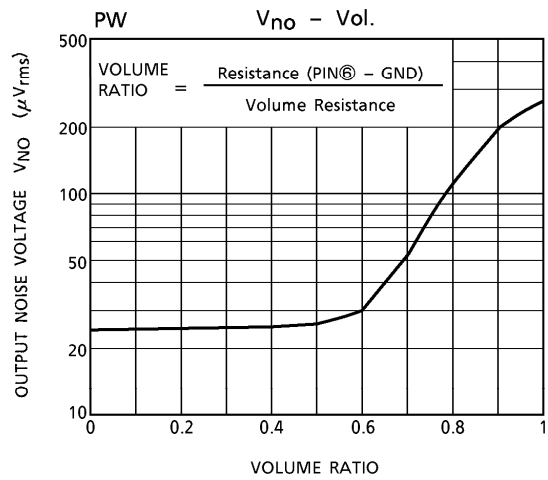
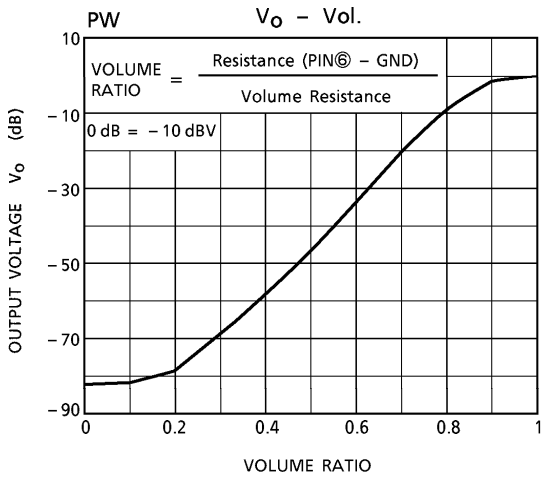

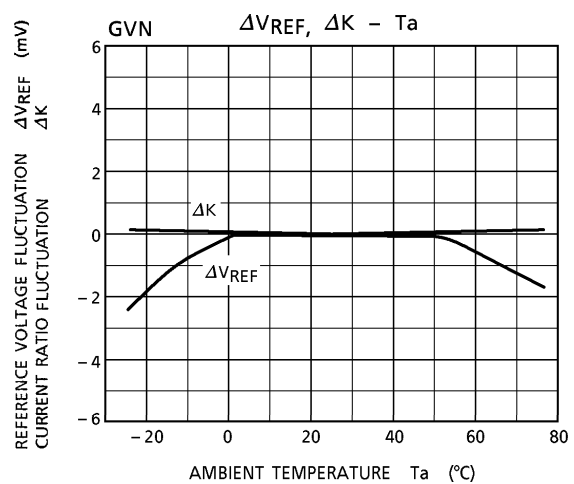
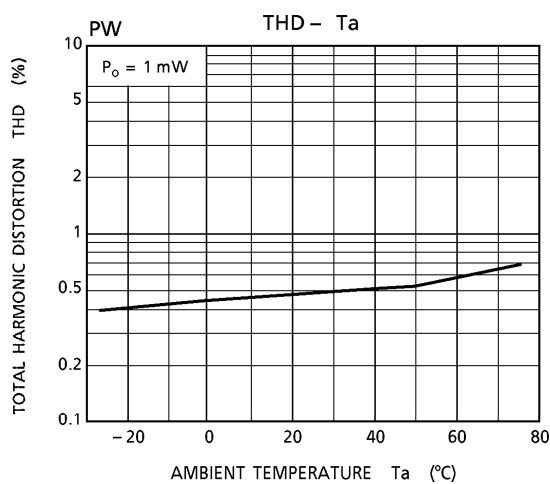
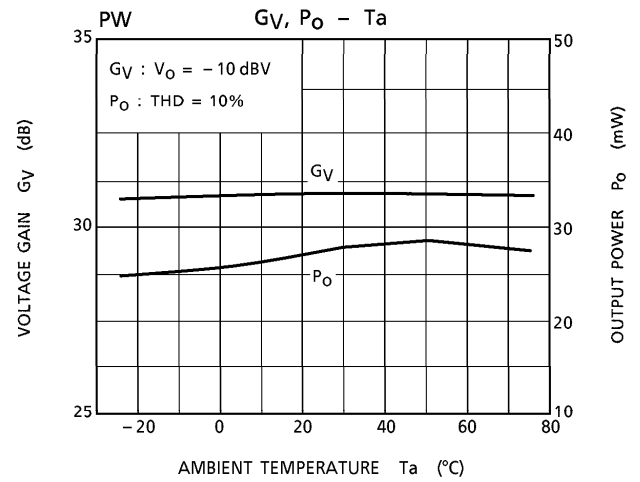
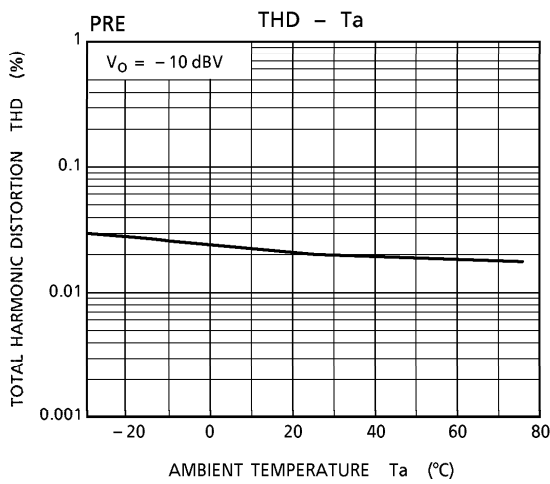
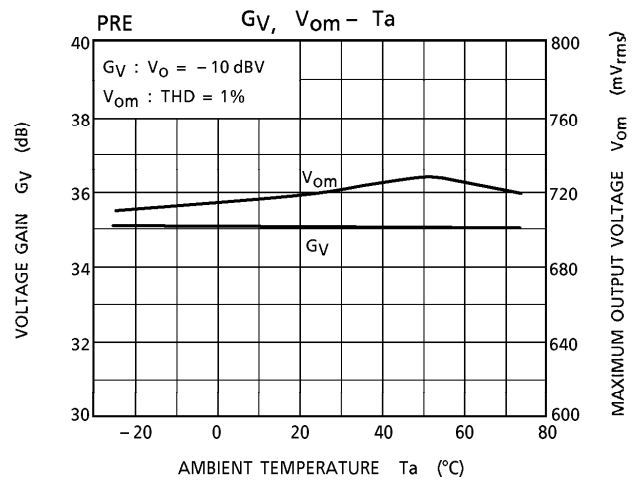
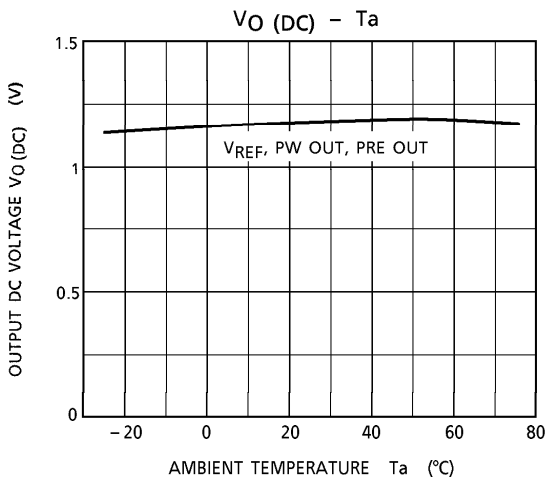

APPLICATION CIRCUIT

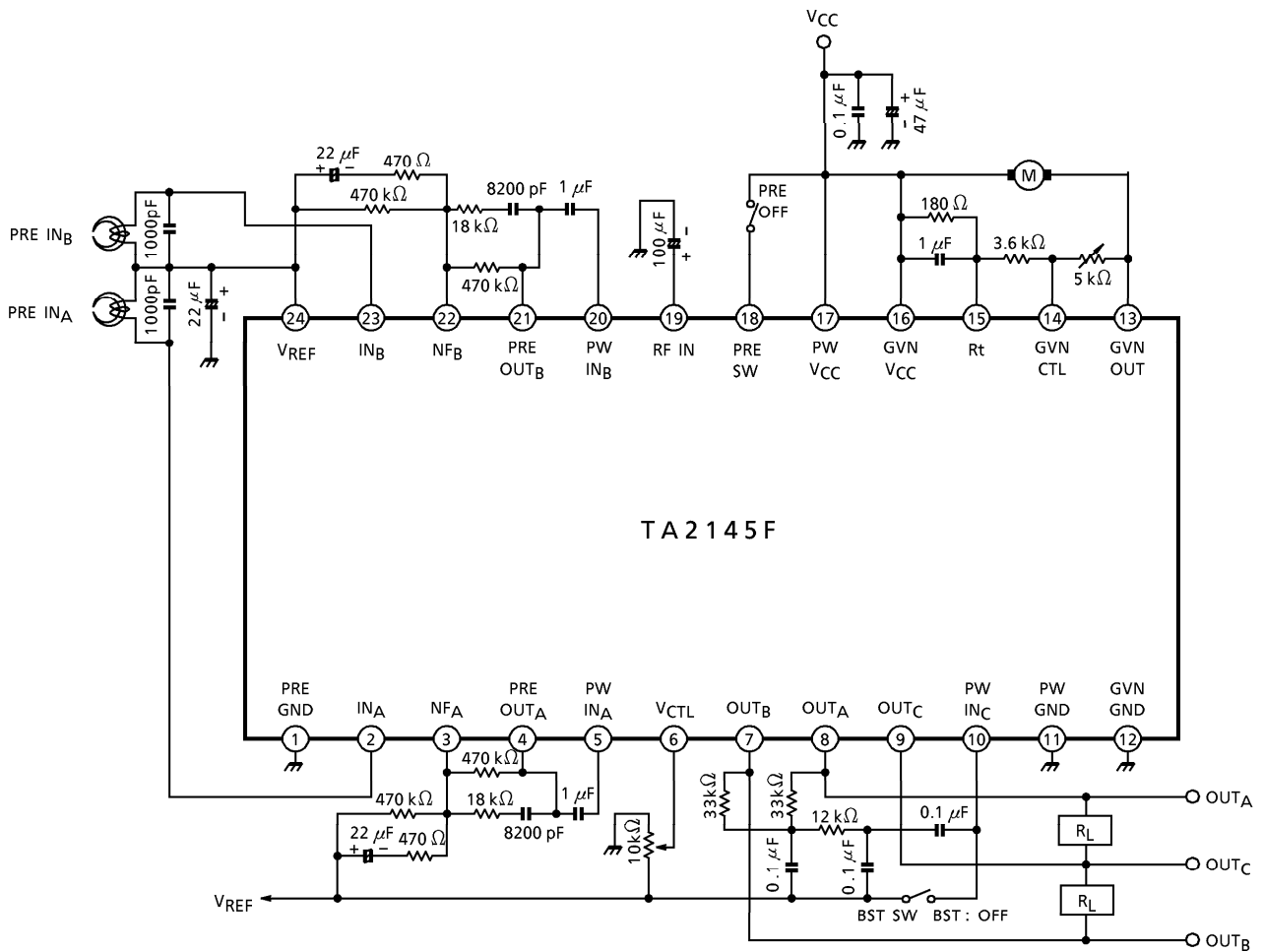

PACKAGE DIMENSIONS
SSOP24-P-300-1.00

Unit : mm

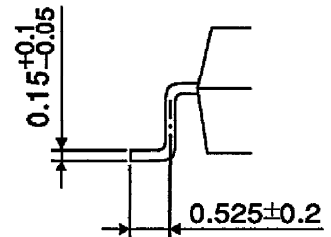
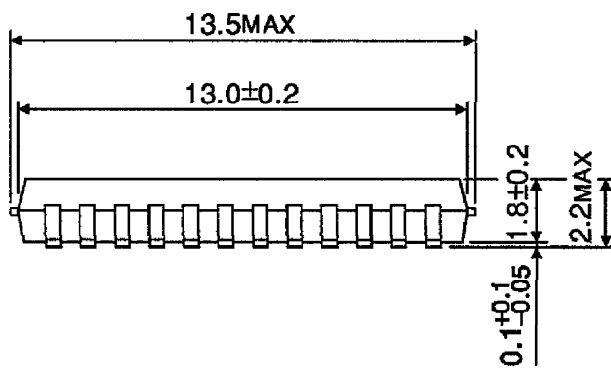
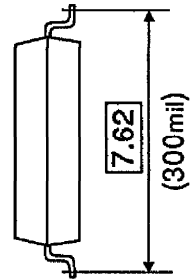
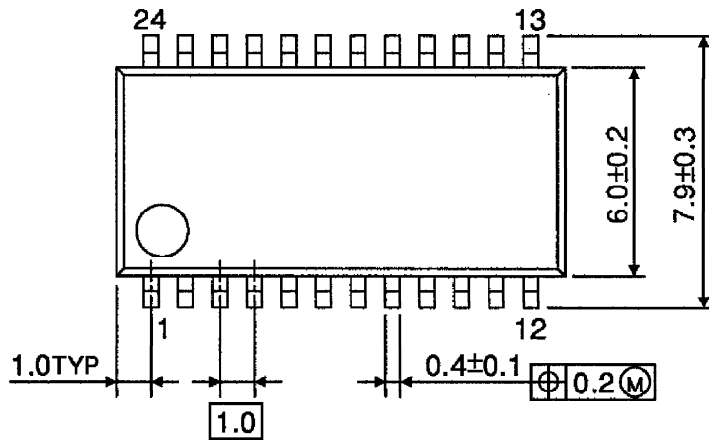

Weight : 0.32 g (Typ.)