

### APPLICATIONS

- UPS
- Induction Heating
- A.C. Motor Drives
- Switch Mode Power Supplies
- Choppers

### KEY PARAMETERS

$V_{DRM}$	<b>1400V</b>
$I_{T(RMS)}$	<b>400A</b>
$I_{TSM}$	<b>4000A</b>
$dV/dt$	<b>1000V/<math>\mu</math>s</b>
$dI/dt$	<b>1000A/<math>\mu</math>s</b>
$t_q$	<b>10.0<math>\mu</math>s</b>

### FEATURES

- Low Loss Asymmetrical Diffusion Structure
- Fully Characterised For Operation up to 20kHz
- High  $dI/dt$  and  $dV/dt$  ratings

### VOLTAGE RATINGS

Type Number	Repetitive Peak Off-state Voltage $V_{DRM}$ V	Repetitive Peak Reverse Voltage $V_{RRM}$ V
TA449 14 W	1400	10
TA449 12 W	1200	10
TA449 10 W	1000	10

Lower voltage grades available.

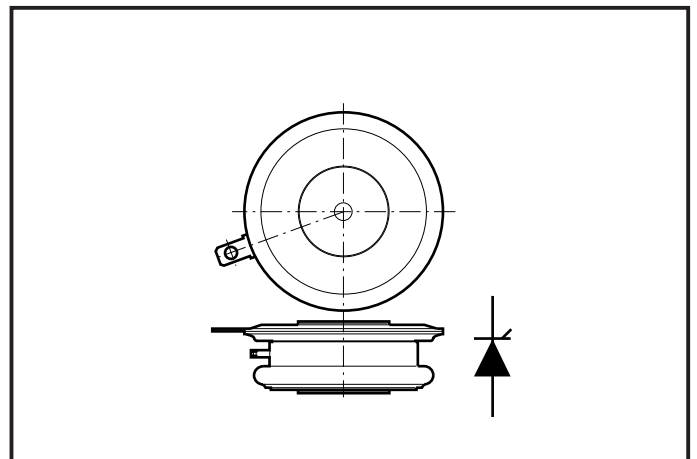

Outline type code: MU86.  
See Package Details for further information.

### CURRENT AND SURGE RATINGS

Symbol	Parameter	Conditions	Max.	Units
<b>Double Side Cooled</b>				
$I_{T(AV)}$	Mean on-state current	Half sine wave, duty cycle 50%, $T_{case} = 80^{\circ}C, T_j = 125^{\circ}C.$	255	A
$I_{T(RMS)}$	RMS value		400	A
$I_{TSM}$	Surge (non-repetitive) on-state current	$T_j = 125^{\circ}C, t_p = 1ms, V_R = 0$	4000	A
$I^2t$	$I^2t$ for fusing	$t_p \geq 10ms$	$80 \times 10^3$	$A^2s$

## THERMAL AND MECHANICAL DATA

Symbol	Parameter	Conditions		Min.	Max.	Units
$R_{th(j-c)}$	Thermal resistance - junction to case	Double side cooled	dc	-	0.07	°C/W
		Single side cooled	Anode dc	-	0.133	°C/W
			Cathode dc	-	0.154	°C/W
$R_{th(c-h)}$	Thermal resistance - case to heatsink	Clamping force 5.0kN with mounting compound	Double side	-	0.02	°C/W
			Single side	-	0.04	°C/W
$T_{vj}$	Virtual junction temperature	On-state (conducting)		-	135	°C
		Reverse (blocking)		-	125	°C
$T_{stg}$	Storage temperature range			-40	150	°C
-	Clamping force			4.5	5.5	kN

## DYNAMIC CHARACTERISTICS

Symbol	Parameter	Conditions		Typ.	Max.	Units
$V_{TM}$	Maximum on-state voltage	At 600A peak, $T_{case} = 125^{\circ}C$		-	2.9	V
$I_{RRM}$	Peak reverse current	At $V_{RRM}$ , $T_{case} = 125^{\circ}C$		-	40	mA
$I_{DRM}$	Off-state current	At $V_{DRM}$ , $T_{case} = 125^{\circ}C$		-	1	mA
dV/dt	Maximum linear rate of rise of off-state voltage	To 60% $V_{DRM}$ , $T_j = 125^{\circ}C$ , Gate open circuit		-	1000	V/ $\mu$ s
dI/dt	Rate of rise of on-state current	Gate source 20V, 20 $\Omega$ $t_r \leq 5\mu$ s.	Non-repetitive	-	1000	A/ $\mu$ s
			Repetitive	-	500	A/ $\mu$ s
$I_H$	Holding current	$T_j = 25^{\circ}C$ , $I_{TM} = 1A$ , $V_D = 12V$		-	80	mA
$I_L$	Latching current	$T_j = 25^{\circ}C$ , $I_G = 0.5A$ , $V_D = 12V$		-	300	mA
$t_q$	Max. turn-off time	VR = DF451 voltage drop, $T_j = 125^{\circ}C$ , $I_{TM} = 200A$ , dV/dt = 400V/ $\mu$ s (linear to 60% $V_{DRM}$ ), tdI <sub>R</sub> /dt = 30A/ $\mu$ s Gate open.		-	10	$\mu$ s
$t_{gt}$	Typ. turn-on time (total)	$T_j = 25^{\circ}C$ , $I_T = 50A$ , $V_D = 300V$ , $I_G = 1A$ , dI/dt = 50A/ $\mu$ s, dI <sub>G</sub> /dt = 1A/ $\mu$ s		3	-	$\mu$ s
$t_{gd}$	Typ. delay time			1.5	-	$\mu$ s

## GATE TRIGGER CHARACTERISTICS AND RATINGS

Symbol	Parameter	Conditions	Min.	Max.	Units
$V_{GT}$	Gate trigger voltage	$V_{DWM} = 12V, R_L = 3\Omega, T_{case} = 25^\circ C$	-	5	V
$I_{GT}$	Gate trigger current	$V_{DWM} = 12V, R_L = 3\Omega, T_{case} = 25^\circ C$	-	400	mA
$V_{GD}$	Min. non trigger voltage	-	0.2	-	V
$V_{RGM}$	Peak reverse gate voltage	-	-	5	V
$I_{FGM}$	Peak forward gate current	-	-	4	A
$P_{GM}$	Peak gate power	-	-	16	W
$P_{G(AV)}$	Average gate power	Average time 10ms max	-	3	W

CURVES

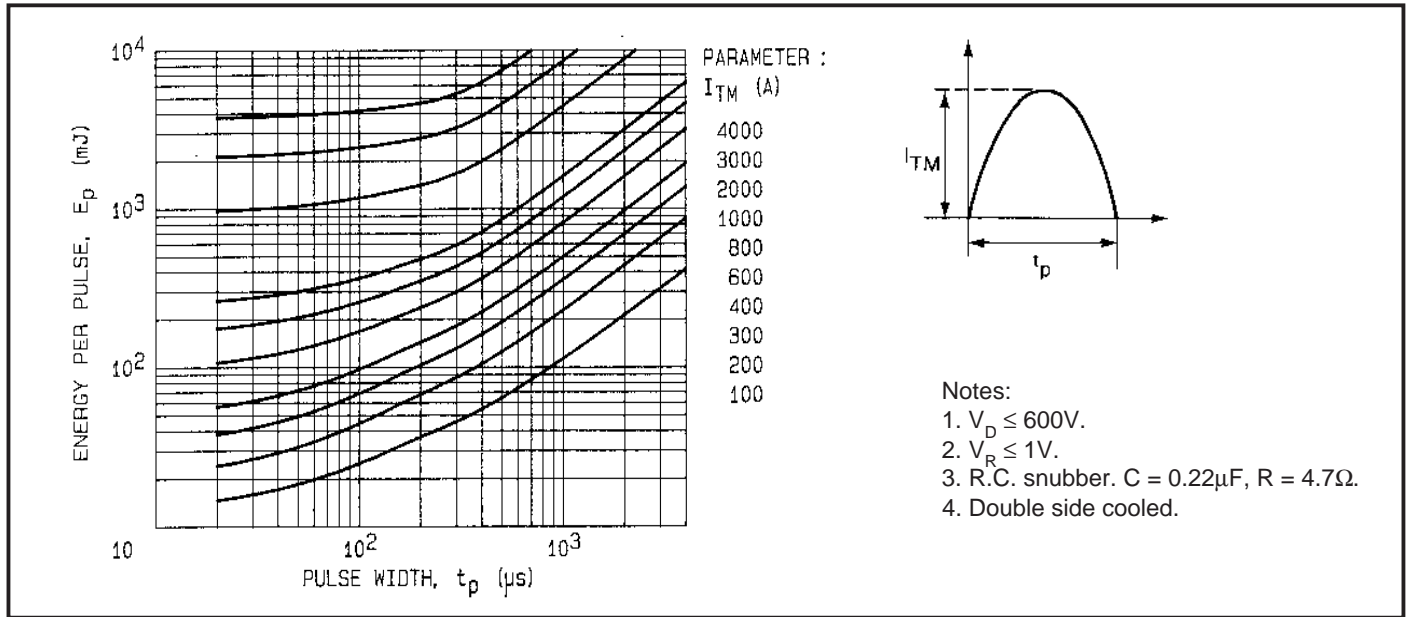

Fig.1 Energy per pulse for sinusoidal pulses.

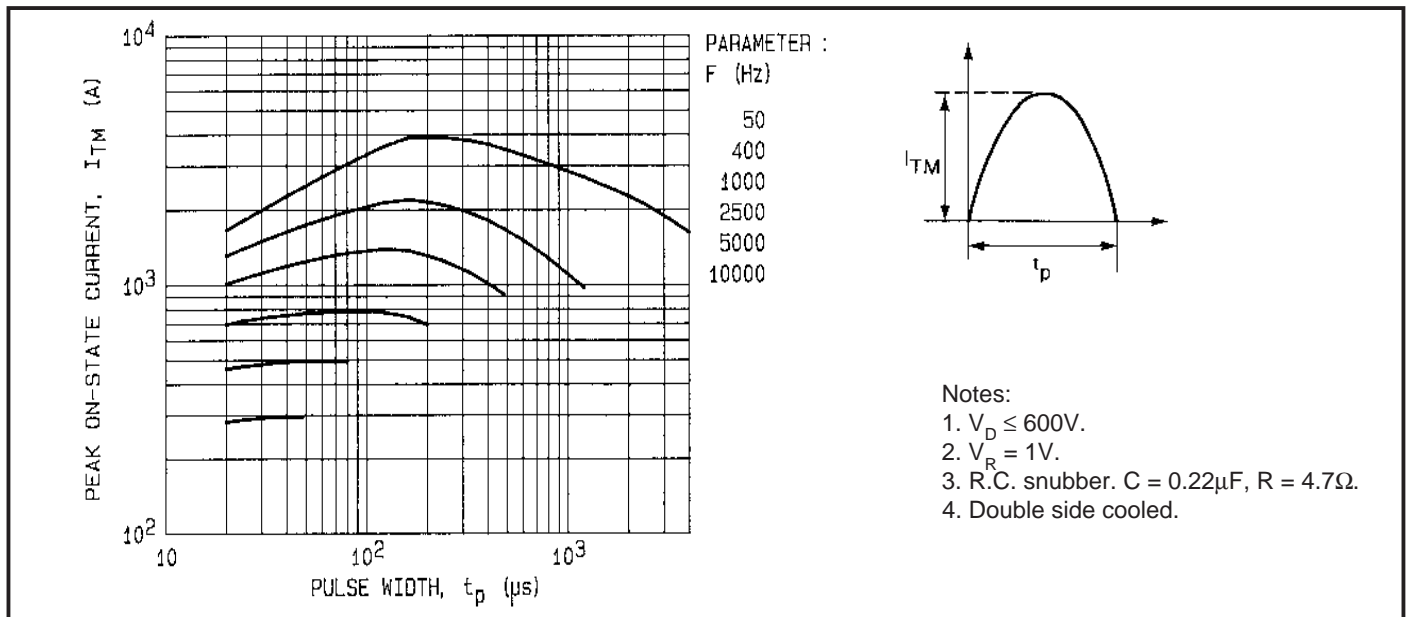

Fig.2 Maximum allowable peak on-state current vs pulse width for  $T_{case} = 65^\circ C$ .

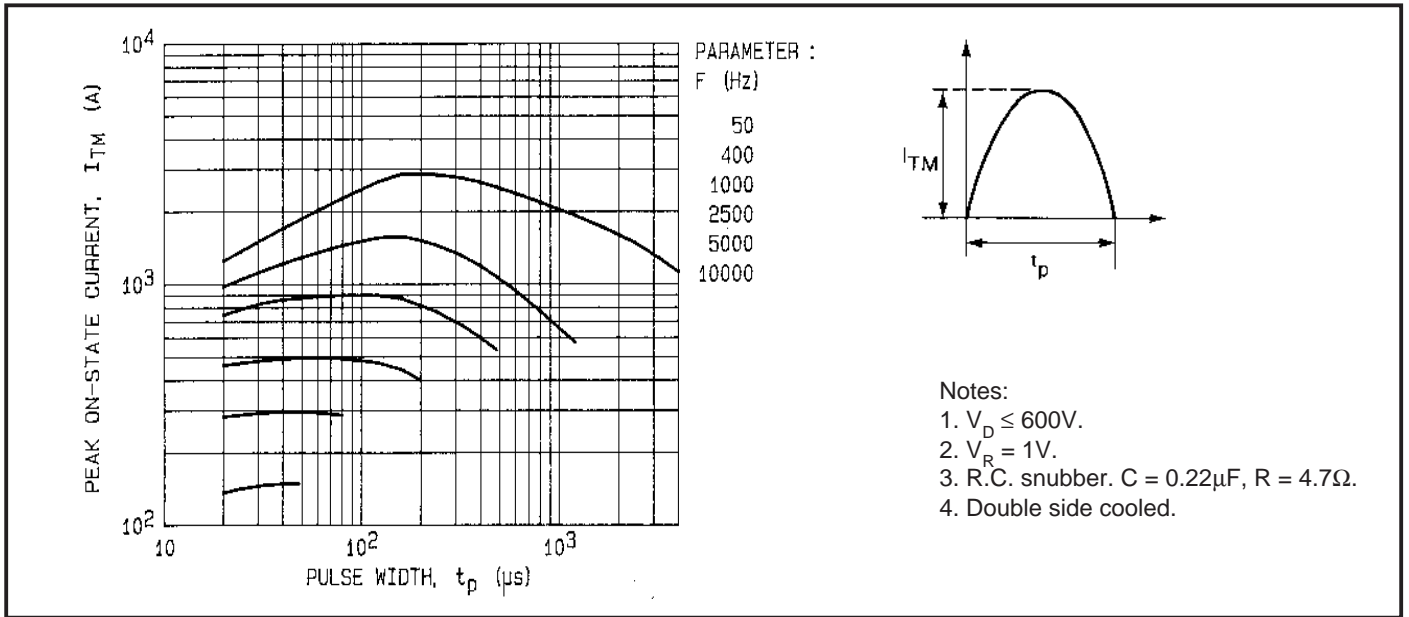

Fig.3 Maximum allowable peak on-state current vs pulse width for  $T_{case} = 90^\circ C$ .

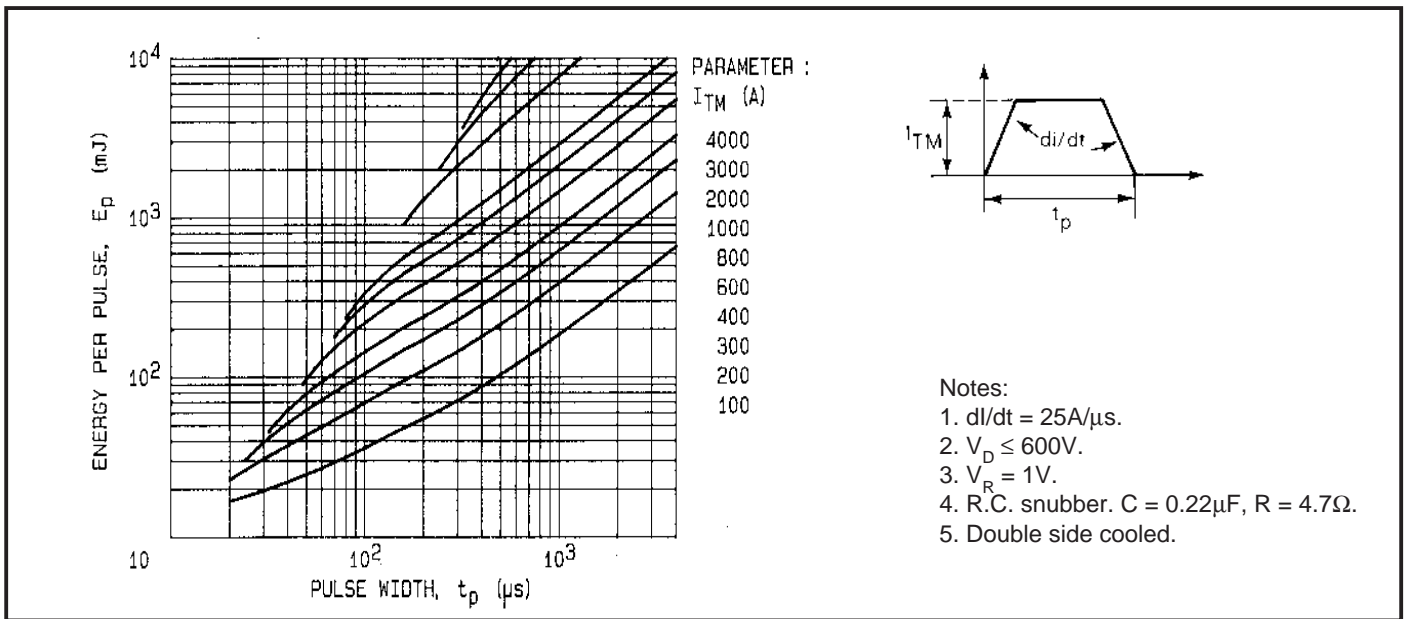

Fig.4 Energy per pulse for trapezoidal pulses

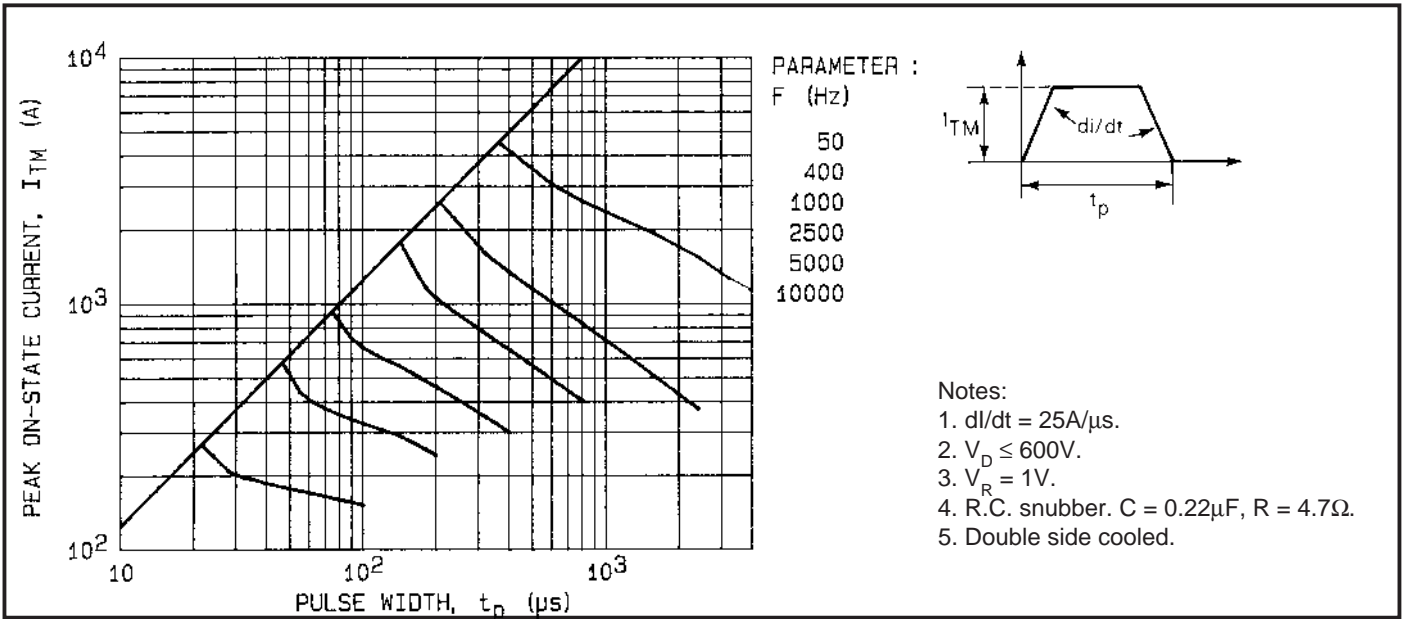

Fig.5 Maximum allowable peak on-state current vs pulse width for  $T_{case} = 65^\circ C$ .

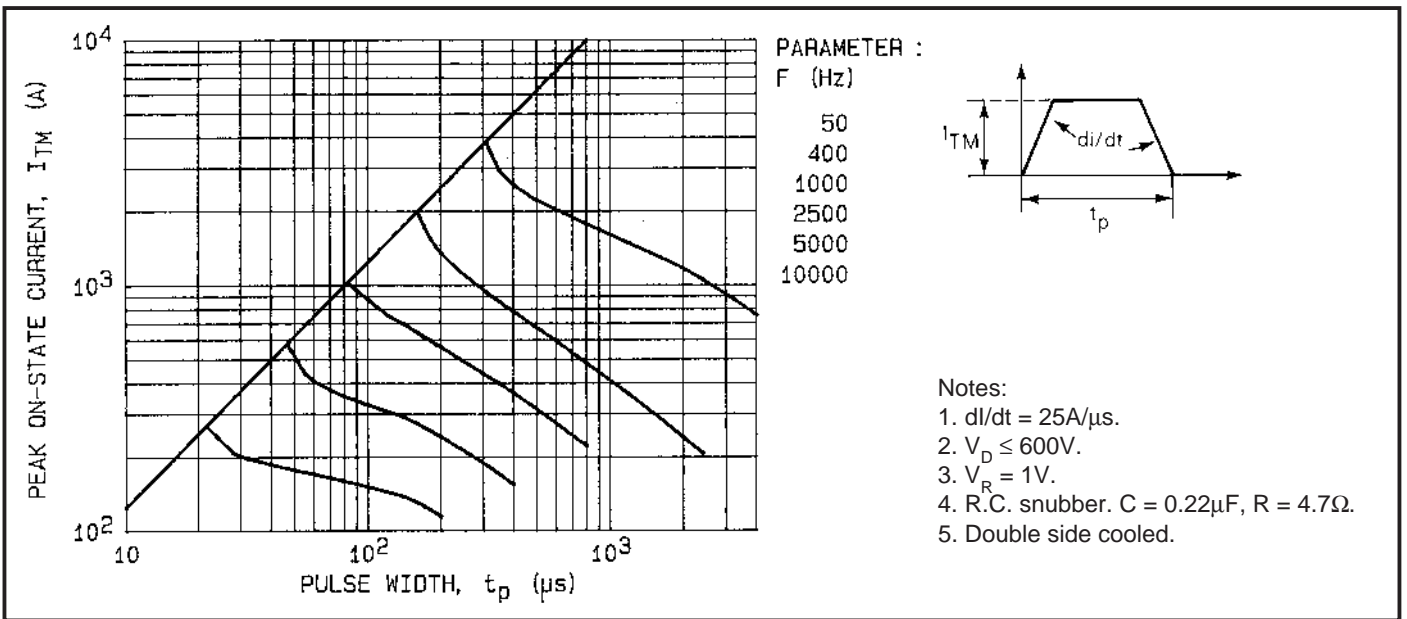

Fig.6 Maximum allowable peak on-state current vs pulse width for  $T_{case} = 90^\circ C$ .

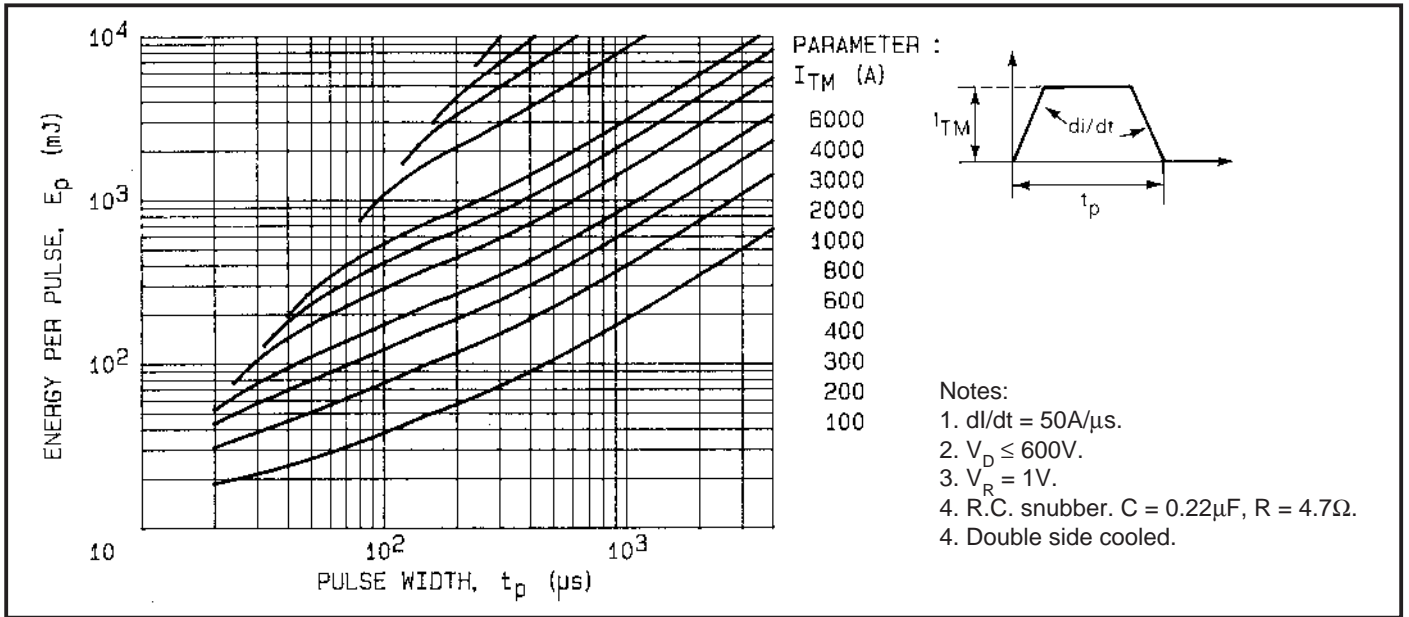

Fig.7 Energy per pulse for trapezoidal pulses.

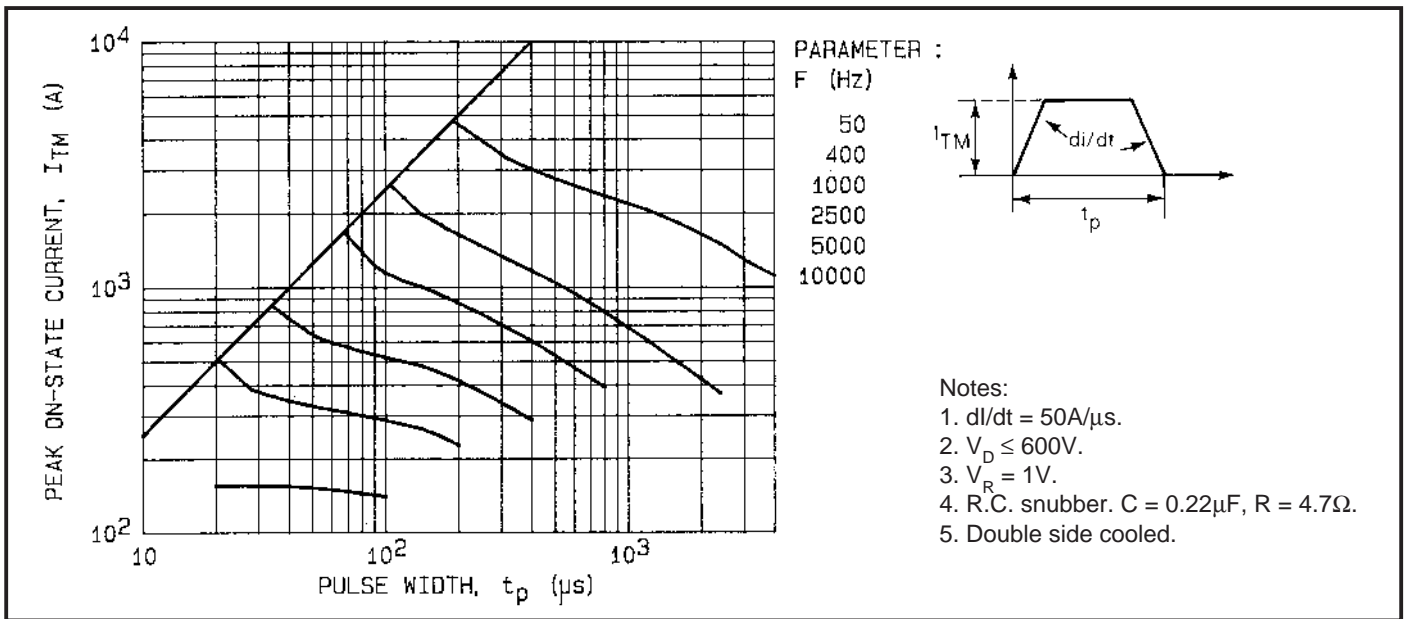

Fig.6 Maximum allowable peak on-state current vs pulse width for  $T_{case} = 90^\circ C$ .

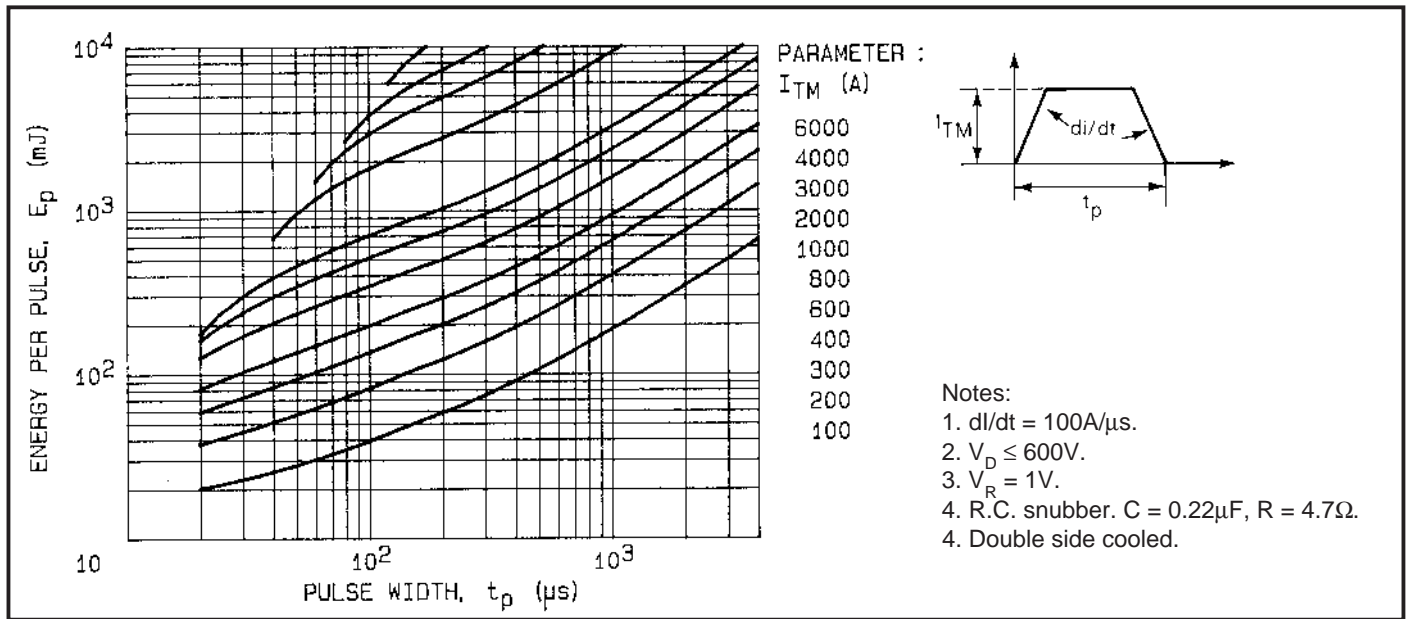

Fig.10 Energy per pulse for trapezoidal pulses.

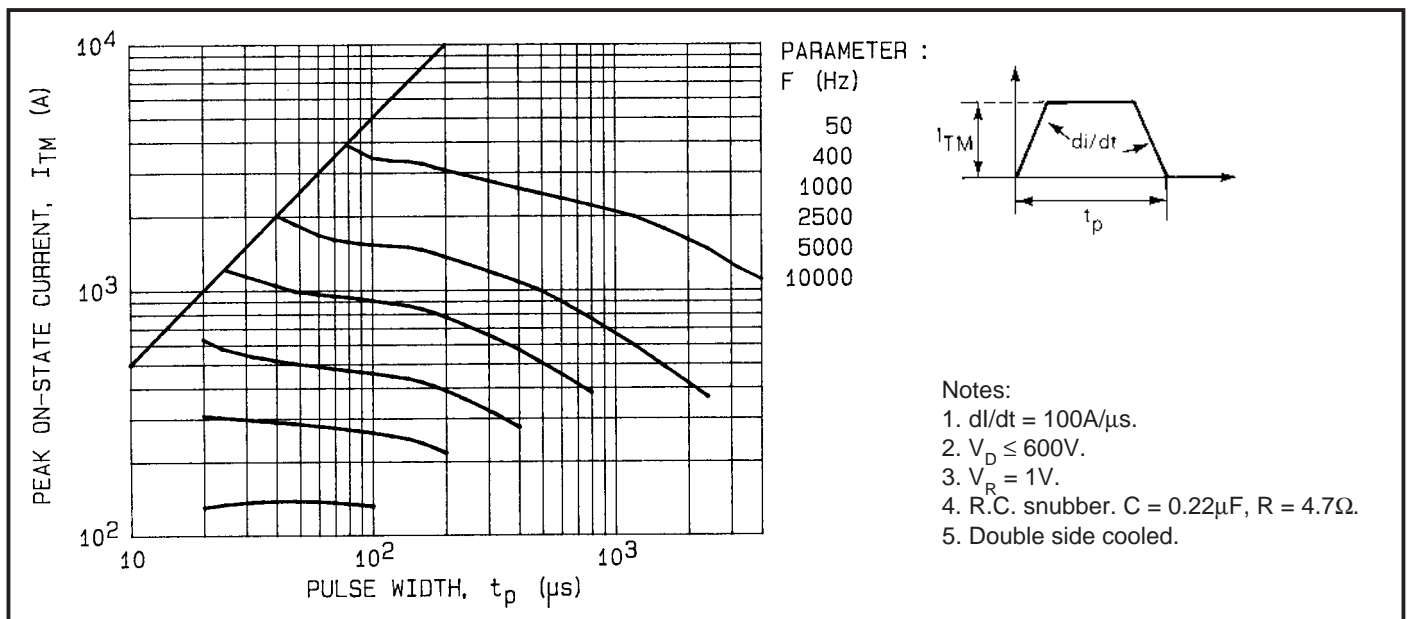

Fig.11 Maximum allowable peak on-state current vs pulse width for  $T_{case} = 65^\circ C$ .



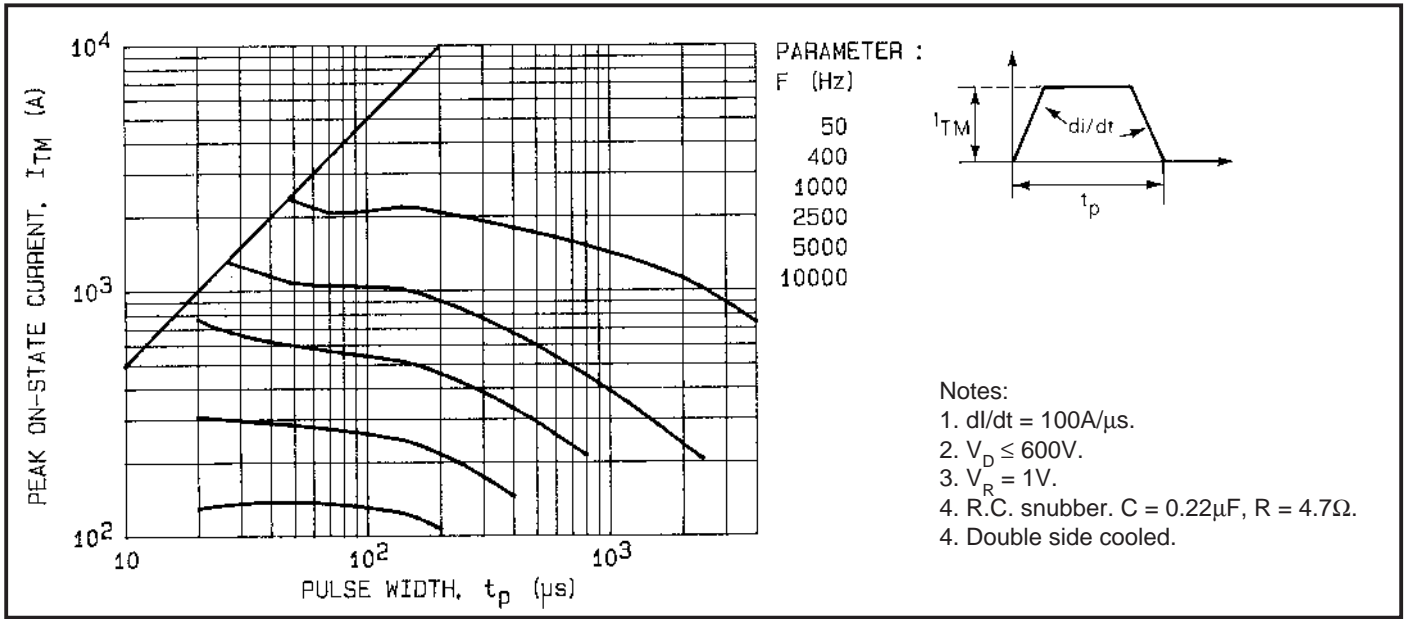

Fig.12 Maximum allowable peak on-state current vs pulse width for  $T_{case} = 90^\circ C$ .

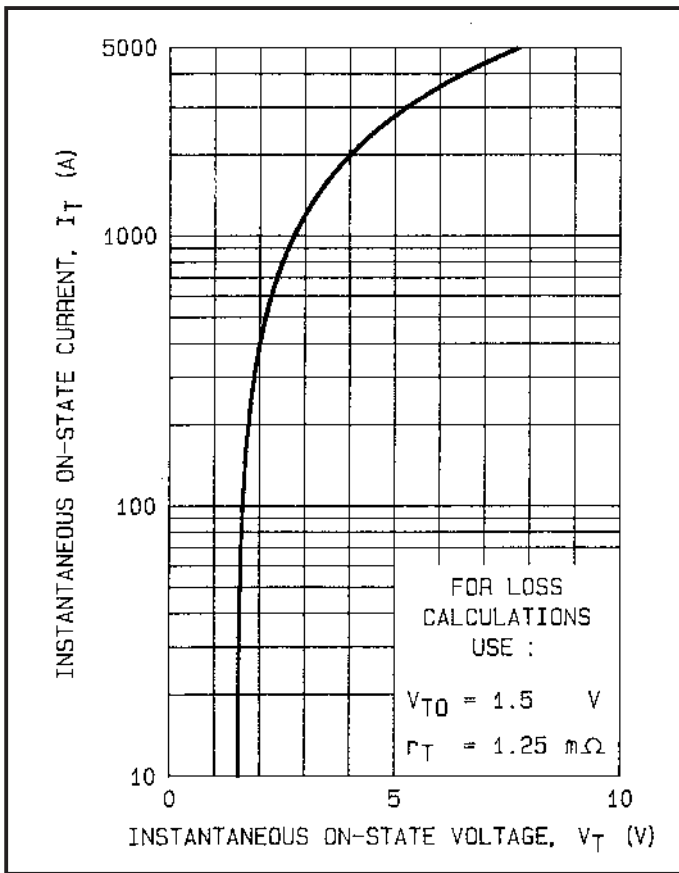

Fig.13 Maximum on-state conduction characteristic ( $T_j = 125^\circ C$ )

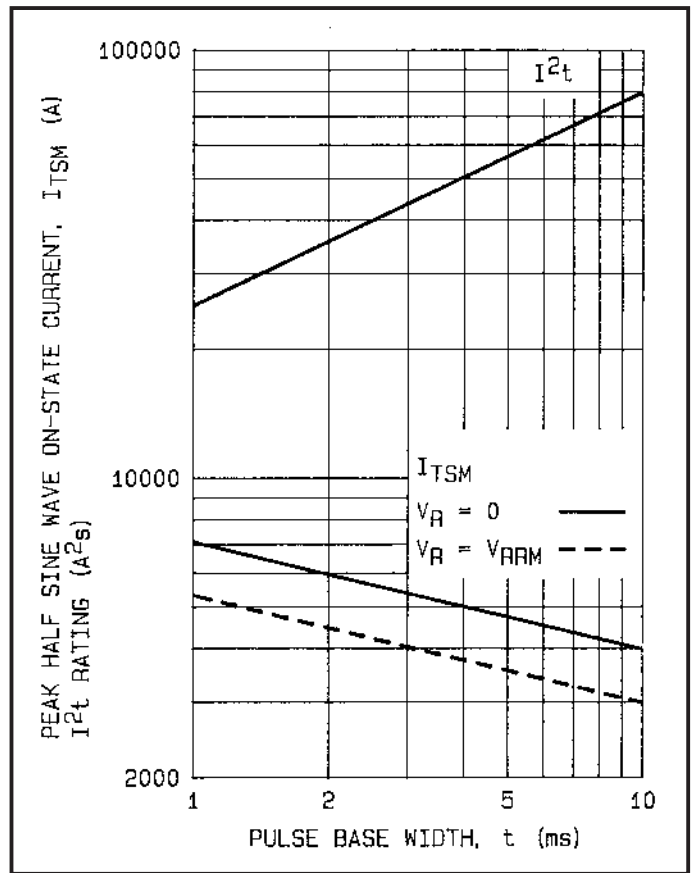

Fig.14 Non-repetitive sub-cycle surge on-state current and  $I^2t$  rating. (Initial  $T_j = 125^\circ C$ )

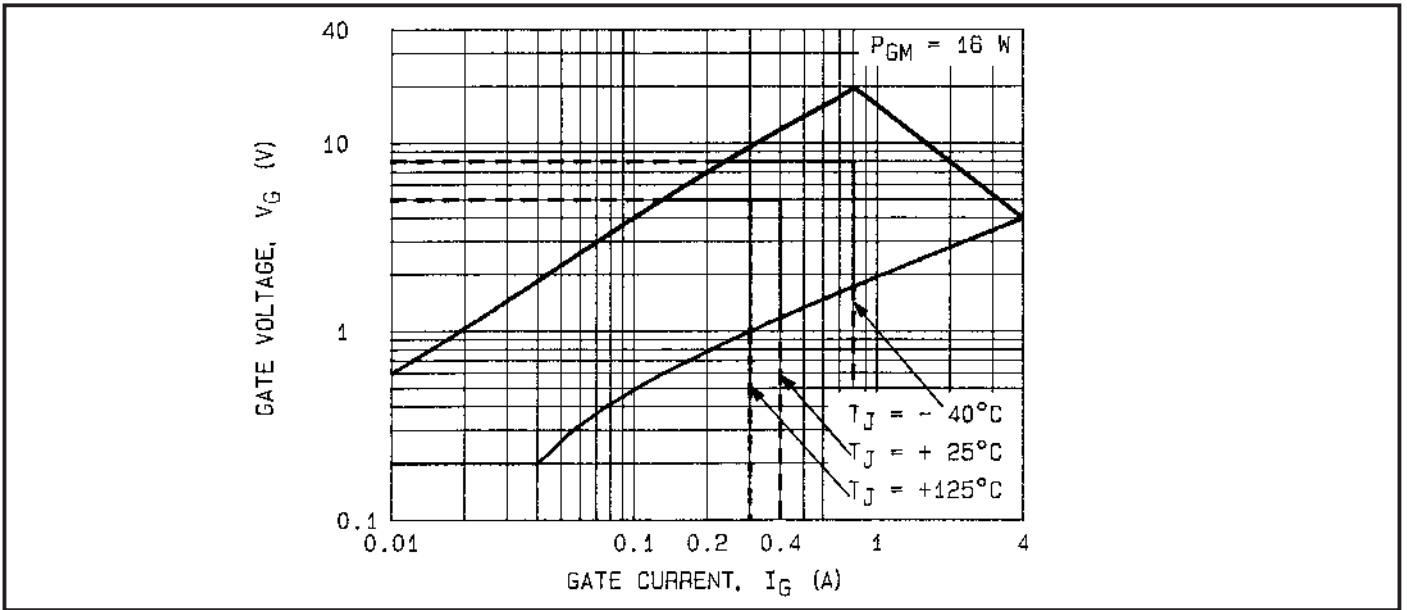

Fig.15 Gate trigger characteristics

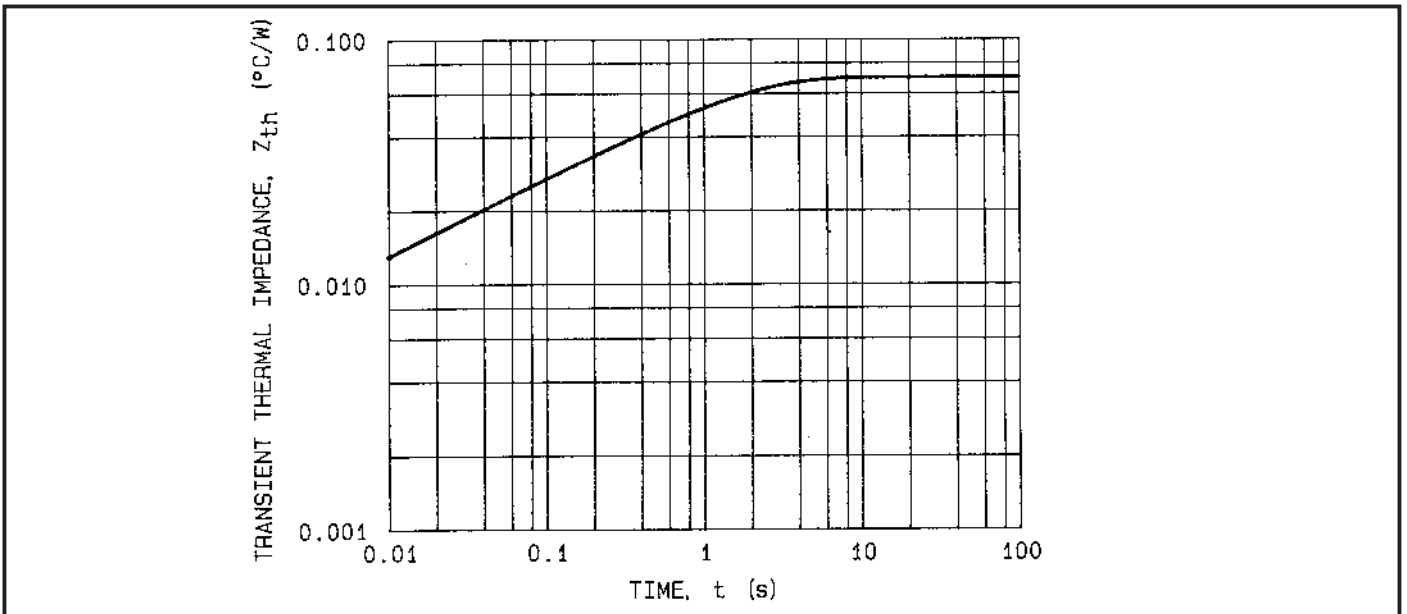
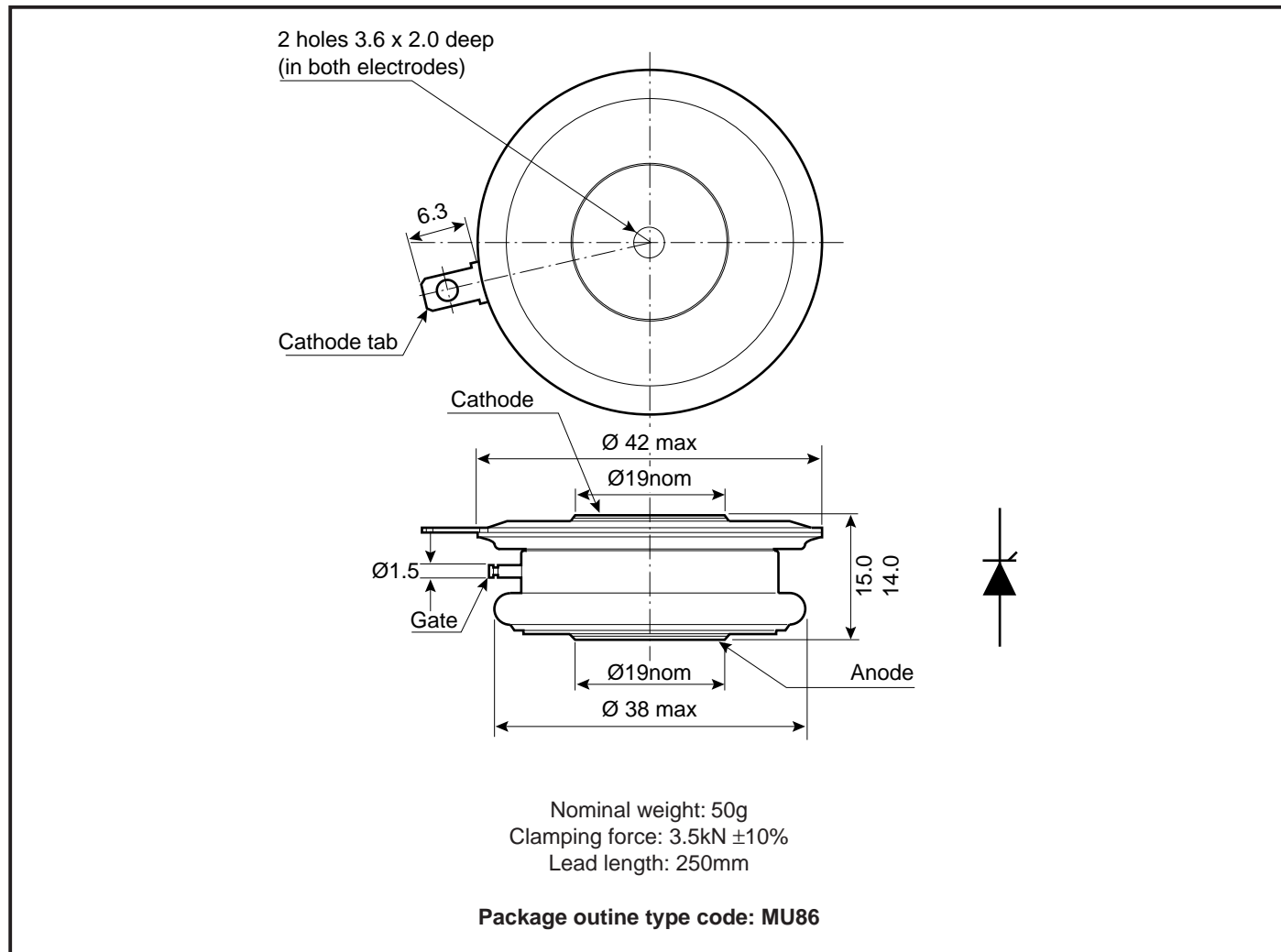

Fig.16 Transient thermal impedance - junction to case (double side cooled)

## PACKAGE DETAILS

For further package information, please contact your local Customer Service Centre. All dimensions in mm, unless stated otherwise. DO NOT SCALE.



## ASSOCIATED PUBLICATIONS

Title	Application Note Number
Calculating the junction temperature or power semiconductors	AN4506
Gate triggering and the use of gate characteristics	AN4840
Recommendations for clamping power semiconductors	AN4839
The effect of temperature on thyristor performance	AN4870
Thyristor and diode measurement with a multi-meter	AN4853
Turn-on performance of thyristors in parallel	AN4999
Use of $V_{TO}$ , $r_T$ on-state characteristic	AN5001

**POWER ASSEMBLY CAPABILITY**

The Power Assembly group was set up to provide a support service for those customers requiring more than the basic semiconductor, and has developed a flexible range of heatsink / clamping systems in line with advances in device types and the voltage and current capability of our semiconductors.

We offer an extensive range of air and liquid cooled assemblies covering the full range of circuit designs in general use today. The Assembly group continues to offer high quality engineering support dedicated to designing new units to satisfy the growing needs of our customers.

Using the up to date CAD methods our team of design and applications engineers aim to provide the Power Assembly Complete solution (PACs).

**DEVICE CLAMPS**

Disc devices require the correct clamping force to ensure their safe operation. The PACs range offers a varied selection of pre-loaded clamps to suit all of our manufactured devices. This include cube clamps for single side cooling of 'T' 22mm

Clamps are available for single or double side cooling, with high insulation versions for high voltage assemblies.

Please refer to our application note on device clamping, AN4839

**HEATSINKS**

Power Assembly has it's own proprietary range of extruded aluminium heatsinks. They have been designed to optimise the performance of our semiconductors. Data with respect to air natural, forced air and liquid cooling (with flow rates) is available on request.

For further information on device clamps, heatsinks and assemblies, please contact your nearest Sales Representative or the factory.



<http://www.dynexsemi.com>

[e-mail: power\\_solutions@dynexsemi.com](mailto:power_solutions@dynexsemi.com)

**HEADQUARTERS OPERATIONS**  
**DYNEX SEMICONDUCTOR LTD**  
Doddington Road, Lincoln.  
Lincolnshire. LN6 3LF. United Kingdom.  
Tel: 00-44-(0)1522-500500  
Fax: 00-44-(0)1522-500550

**CUSTOMER SERVICE CENTRES**  
**France, Benelux, Italy and Spain** Tel: +33 (0)1 69 18 90 00. Fax: +33 (0)1 64 46 54 50  
**North America** Tel: 011-800-5554-5554. Fax: 011-800-5444-5444  
**UK, Germany, Scandinavia & Rest Of World** Tel: +44 (0)1522 500500. Fax: +44 (0)1522 500020

**DYNEX POWER INC.**  
Unit 7 - 58 Antares Drive,  
Nepean, Ontario, Canada K2E 7W6.  
Tel: 613.723.7035  
Fax: 613.723.1518  
Toll Free: 1.888.33.DYNEX (39639)

**SALES OFFICES**  
**France, Benelux, Italy and Spain** Tel: +33 (0)1 69 18 90 00. Fax: +33 (0)1 64 46 54 50  
**Germany** Tel: 07351 827723  
**North America** Tel: (613) 723-7035. Fax: (613) 723-1518. Toll Free: 1.888.33.DYNEX (39639) /  
Tel: (831) 440-1988. Fax: (831) 440-1989 / Tel: (949) 733-3005. Fax: (949) 733-2986.  
**UK, Germany, Scandinavia & Rest Of World** Tel: +44 (0)1522 500500. Fax: +44 (0)1522 500020  
These offices are supported by Representatives and Distributors in many countries world-wide.  
© Dynex Semiconductor 2000 Publication No. DS4681-5 Issue No. 5.0 January 2000  
**TECHNICAL DOCUMENTATION – NOT FOR RESALE. PRINTED IN UNITED KINGDOM**

**Datasheet Annotations:**

- Dynex Semiconductor annotate datasheets in the top right hand corner of the front page, to indicate product status. The annotations are as follows:-
- Target Information:** This is the most tentative form of information and represents a very preliminary specification. No actual design work on the product has been started.
- Preliminary Information:** The product is in design and development. The datasheet represents the product as it is understood but details may change.
- Advance Information:** The product design is complete and final characterisation for volume production is well in hand.
- No Annotation:** The product parameters are fixed and the product is available to datasheet specification.

This publication is issued to provide information only which (unless agreed by the Company in writing) may not be used, applied or reproduced for any purpose nor form part of any order or contract nor to be regarded as a representation relating to the products or services concerned. No warranty or guarantee express or implied is made regarding the capability, performance or suitability of any product or service. The Company reserves the right to alter without prior notice the specification, design or price of any product or service. Information concerning possible methods of use is provided as a guide only and does not constitute any guarantee that such methods of use will be satisfactory in a specific piece of equipment. It is the user's responsibility to fully determine the performance and suitability of any equipment using such information and to ensure that any publication or data used is up to date and has not been superseded. These products are not suitable for use in any medical products whose failure to perform may result in significant injury or death to the user. All products and materials are sold and services provided subject to the Company's conditions of sale, which are available on request.

All brand names and product names used in this publication are trademarks, registered trademarks or trade names of their respective owners.