

**PART NUMBERING GUIDE**

**TABLE 1**

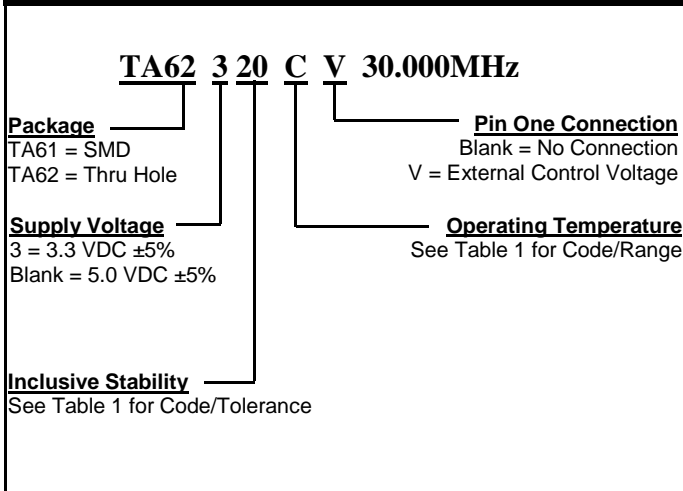

Operating Temperature		Frequency Stability (±ppm) * Denotes Availability of Options					
Range	Code	1.5ppm	2.0ppm	2.5ppm	3.0ppm	3.5ppm	5.0ppm
		15	20	25	30	35	50
0 to 50°C	A	*	*	*	*	*	*
-10 to 60°C	B	*	*	*	*	*	*
-20 to 70°C	C	*	*	*	*	*	*
-30 to 60°C	D		*	*	*	*	*
-30 to 75°C	E		*	*	*	*	*
-35 to 85°C	F			*	*	*	*
-40 to 80°C	G				*	*	*

**ELECTRICAL SPECIFICATIONS**

**Environmental/Mechanical Specifications on page F5**

Frequency Range	9.600MHz to 35.000MHz	
Operating Temperature Range	See Table 1 Above.	
Storage Temperature Range	-40°C to 85°C	
Supply Voltage	3.3 VDC ±5% / 5.0 VDC ±5%	
Load Drive Capability	10TTL Load or 15pF HCMOS Load Maximum	
Internal Trim (Top of Can)	±3ppm Minimum	
Control Voltage (External)	2.5Vdc ±2.0Vdc Positive Transfer Characteristics	
Frequency Deviation	±5ppm Minimum Over Control Voltage	
Aging (@ 25°C)	±1ppm / year Maximum	
Input Current / Duty Cycle / Rise and Fall Time	30mA Maximum / 50±10% / 5nSeconds Maximum	
Output Voltage Logic High (Voh)	w/TTL Load w/HCMOS Load	2.4Vdc Minimum  Vdd - .05Vdc Minimum
Output Voltage Logic Low (Vol)	w/TTL Load w/HCMOS Load	0.4Vdc Maximum  0.5Vdc Maximum
Frequency Stability	Vs. Operating Temperature	See Table 1 Above.
	Vs. Inpput Voltage (±5%)	±0.3ppm Maximum
	Vs. Load (±2pF)	±0.3ppm Maximum

**MECHANICAL DIMENSIONS**

**Marking Guide on page F3-F4**

