

TA7272P

DUAL POWER OPERATIONAL AMPLIFIER

The TA7272P is a dual power operational amplifier. It is intended for use especially DC MOTOR positioning system applications, such as Arm Driver (for Audiodisk Players), head or voice coil motor drivers (for Floppy and Winchester Disk Drivers) and any other power driver applications.

FEATURES

- HSIP 10 Pin Power Package Capsealed.
- Build-in Over Current Protector.
- Few External Parts Required.
- Output Current Up to 1.2 A (PEAK)
- Excellent Crosstalk Characteristics.

BLOCK DIAGRAM

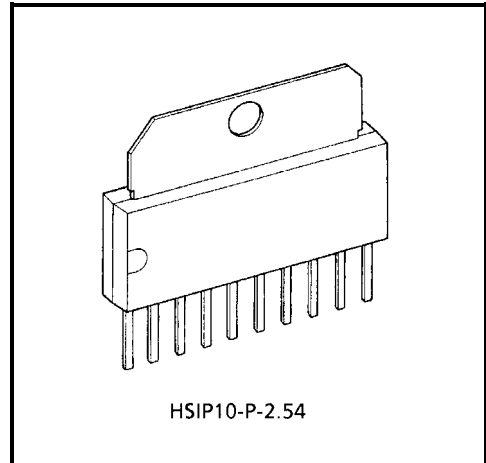
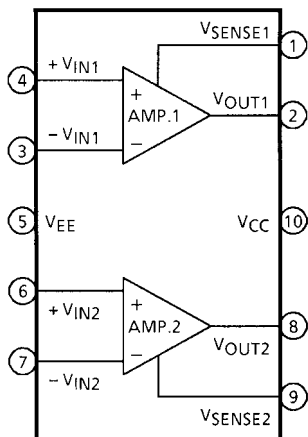

HSIP10-P-2.54

Weight: 2.47 g (Typ.)

PIN FUNCTION

PIN No.	SYMBOL	FUNCTIONAL DESCRIPTION
1	V _{SENSE1}	Amp.1 output current detection terminal
2	V _{OUT1}	Amp.1 output terminal
3	-V _{IN1}	Amp.1 input terminal (-)
4	+V _{IN1}	Amp.1 input terminal (+)
5	V _{EE}	Negative-side power supply terminal
6	+V _{IN2}	Amp.2 input terminal (+)
7	-V _{IN2}	Amp.2 input terminal (-)
8	V _{OUT2}	Amp.2 output terminal
9	V _{SENSE2}	Amp.2 output current detection terminal
10	V _{CC}	Positive-side power supply terminal

MAXIMUM RATINGS (Ta = 25°C)

CHARACTERISTIC	SYMBOL	RATING	UNIT
Supply Voltage	V _{CC} , V _{EE}	±18	V
Output Current	I _O (PEAK)	1.2 (Note)	A
Power Dissipation	P _D	12.5	W
Operating Temperature	T _{opr}	-30~75	°C
Storage Temperature	T _{stg}	-55~150	°C

Note: See V_{CC} - I_O (AVE) MAX. Characteristics
T_c = 25°C

ELECTRICAL CHARACTERISTICS

(Unless otherwise specified, V_{CC} = 15 V, V_{EE} = -15 V, Ta = 25°C)

CHARACTERISTIC	SYMBOL	TEST CIR-CUIT	TEST CONDITION	MIN	TYP.	MAX	UNIT
Quiescent Current	I _{CC}	1	—	—	20	35	mA
Input Off Set Current	I _{IO}	2	—	—	2	100	nA
Input Bias Current	I _I	2	—	—	50	300	nA
Input Off Set Voltage	V _{IO}	1	—	—	1.0	7.0	mV
Output Voltage Swing	Upper	V _{OH}	V _{CC} = ± 15 V, I _O = 300 mA	11.5	12.1	—	V
	Lower	V _{OL}		-11.5	-12.3	—	
	Upper	V _{OH}	V _{CC} = ± 6 V, I _O = 1 A	2.2	3.3	—	V
	Lower	V _{OL}		-2.2	-3.7	—	
Open Loop Gain	G _{VO}	4	—	—	90	—	dB
Input Common Mode Voltage Range	CMR	5	—	±13	±14	—	V
Common Mode Rejection Ratio	CMRR	5	V _{IN} = -10~10 V	90	95	—	dB
Supply Voltage Rejection Ratio	SVRR	5	V _{CC} = -V _{EE} = 6~15V ± 1 V	—	45	125	μV / V
Slew Rate	SR	6	—	—	0.4	—	V / μs
Short Circuit Current	I _{SC}	7	R _{SC} = 0.68 Ω	0.8	1.0	—	A
Cross Talk	C _T	5	V _{IN} = -14~14 V	—	60	—	dB

TEST CIRCUIT 1

I_{CC} , V_{IO}

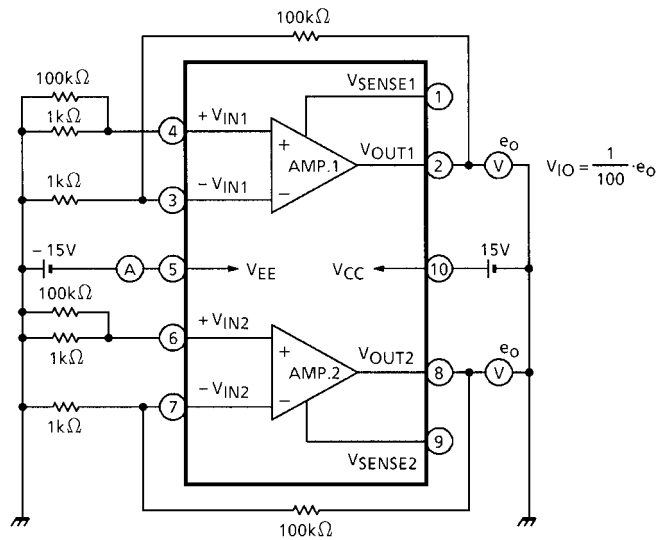

TEST CIRCUIT 2

I_{I+} , I_{I-} , I_{IO}

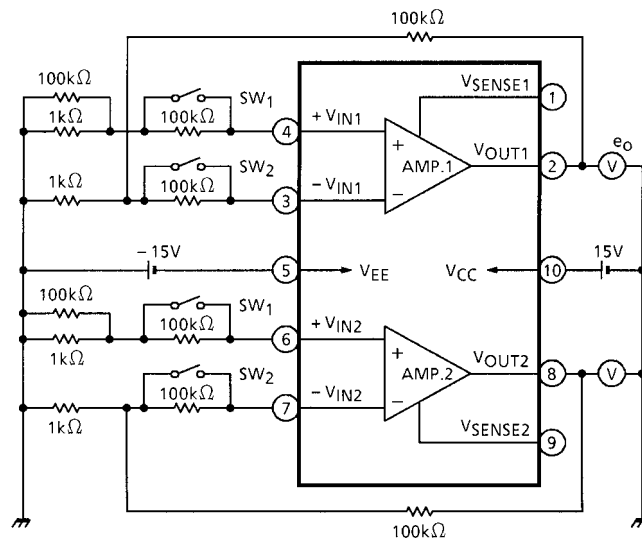

When SW1 and SW2 are closed, the measured value is V_{M1} .

When I_{I+} SW1 is closed and SW2 is open, the measured value is V_{M2} .

$$I_{I+} = \frac{V_{M2} - V_{M1}}{100k} \cdot \frac{1}{100}$$

When I_{I-} SW1 is open and SW2 is closed, the measured value is V_{M3} .

$$I_{I-} = \frac{V_{M3} - V_{M1}}{100k} \cdot \frac{1}{100}$$

When I_{IO} SW1, SW2 is open, the measured value is V_{M4} .

$$I_{IO} = \frac{V_{M4} - V_{M1}}{100k} \cdot \frac{1}{100}$$

TEST CIRCUIT 3

V_{OH} , V_{OL}

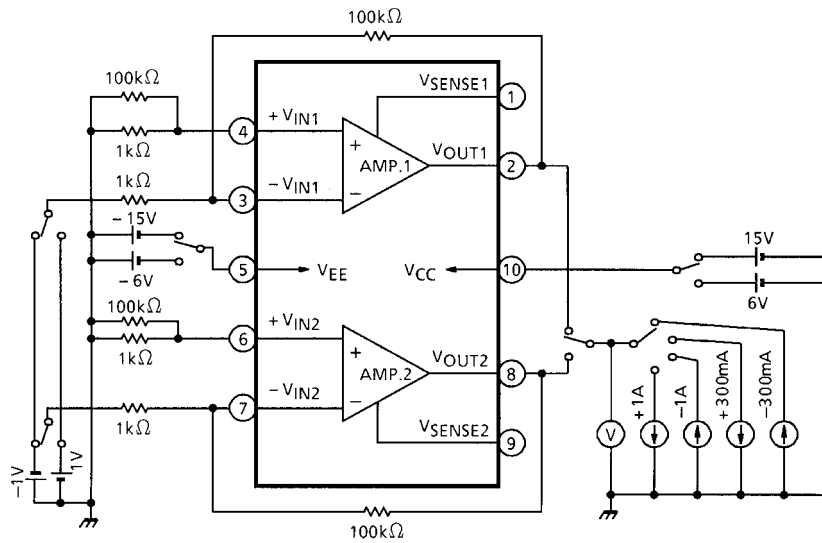

Set $V_{CC} = -V_{EE} = 15\text{ V}$, then $I_O = 300\text{ mA}$

Set $V_{CC} = -V_{EE} = 6\text{ V}$, then $I_O = 1\text{ A}$

TEST CIRCUIT 4

G_{VO}

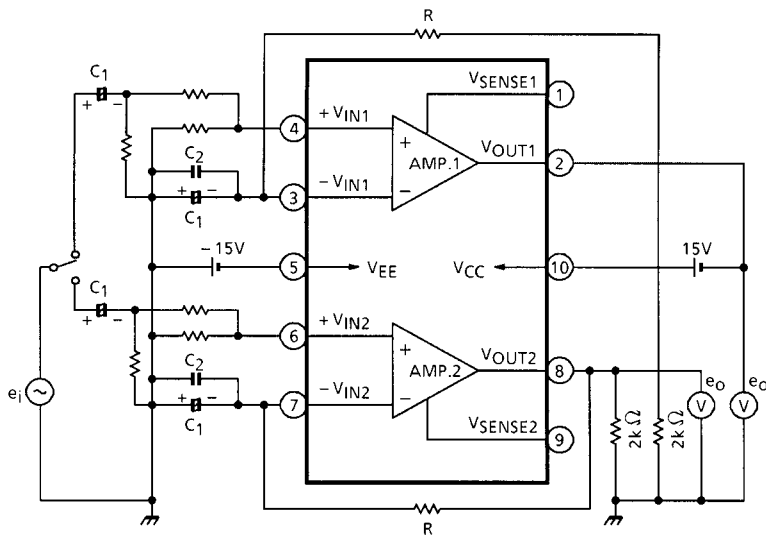

$$G_{VO} = 20 \log e_o / e_i$$

$$R \gg 1 / \omega C_1$$

C_1 : obstruction direct current short-circuit

C_2 : radio frequency short-circuit.

Mica or Titanium capacitor use.

TEST CIRCUIT 5
CMR, CMRR, SVRR, C_T

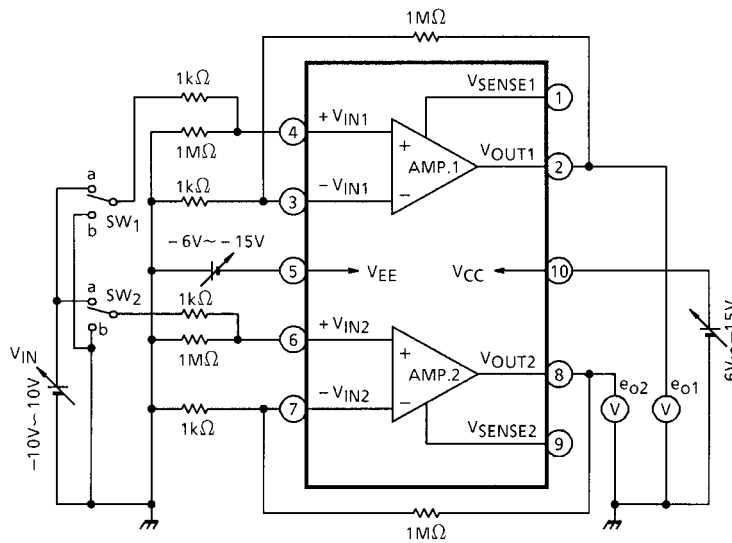

CMR: V_{IN} value where a change in V_{IN} does not cause e_o to operate.

$$CMRR = 20 \log_{10} \frac{\Delta e_o}{\Delta V_{IN}}$$

$$SVRR = 20 \log_{10} \frac{\Delta e_o}{\Delta V_{CC}} \quad \text{or} \quad 20 \log_{10} \frac{\Delta e_o}{\Delta V_{EE}} \quad (V_{IN} = 0 \text{ V})$$

$$C_T = 20 \log_{10} \frac{\Delta e_{o1}}{\Delta V_{IN}} \quad (\text{SW}_1 : \text{b}, \text{SW}_2 : \text{a}) \quad \text{or} \quad 20 \log_{10} \frac{\Delta e_{o2}}{\Delta V_{IN}} \quad (\text{SW}_1 : \text{a}, \text{SW}_2 : \text{b})$$

TEST CIRCUIT 6
SR

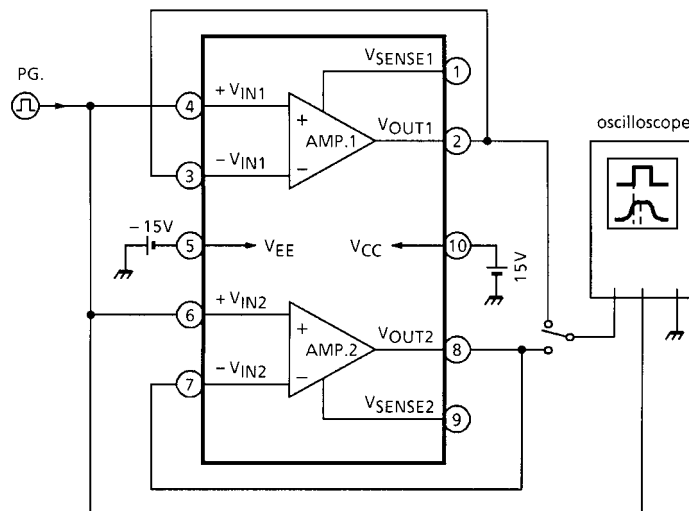

TEST CIRCUIT 7
Isc

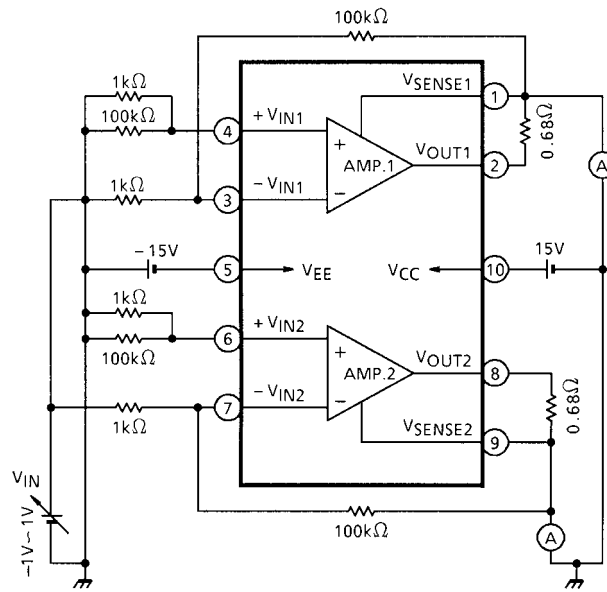

$$I_{SC} = V_M / 0.68 \Omega$$

V_M: V_{IN} detection resistance voltage when a change in V_{IN} triggers the current delimiter.

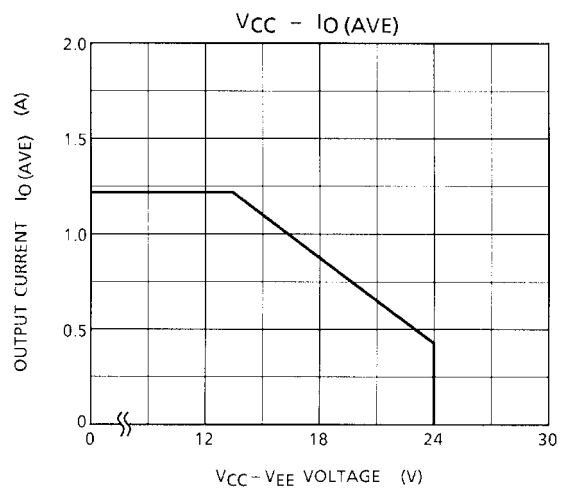
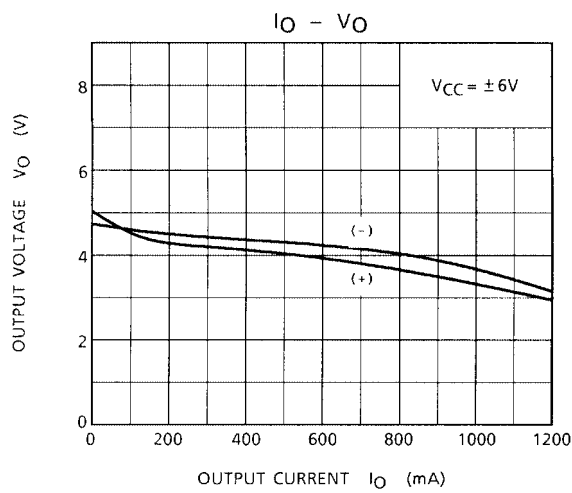
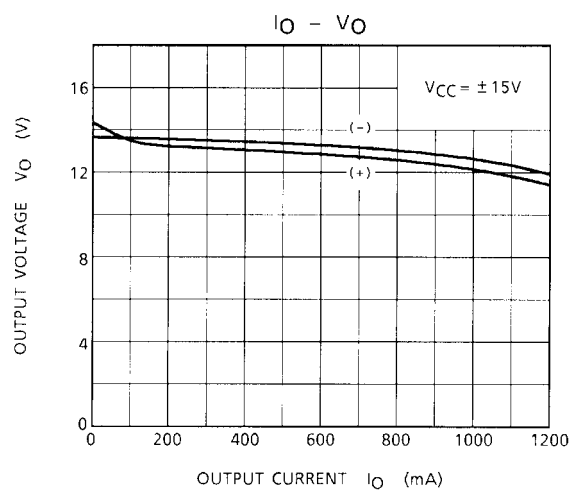
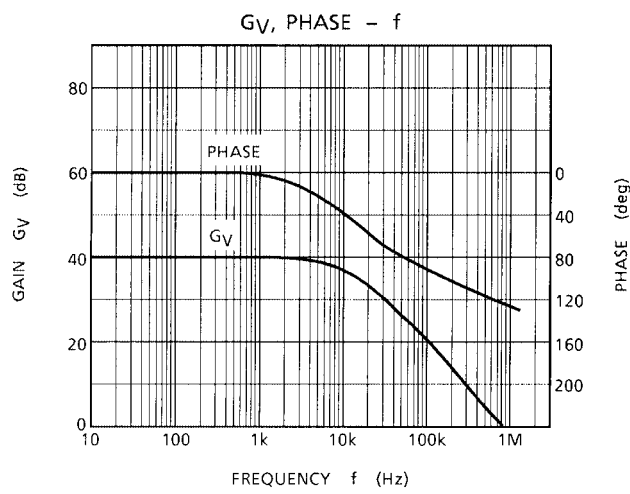
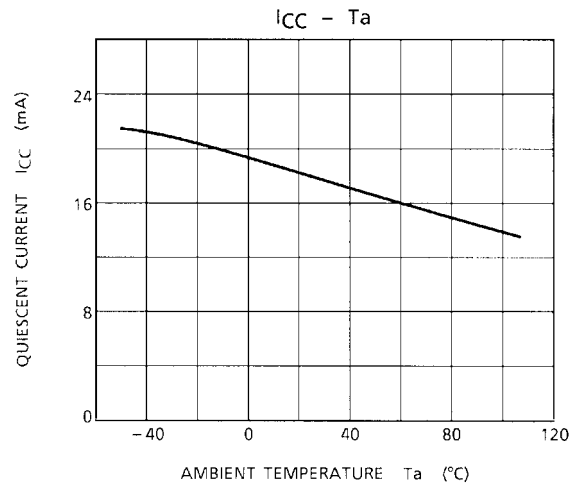
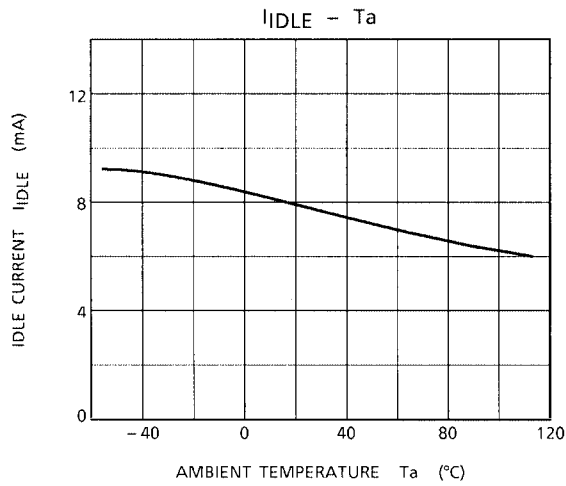

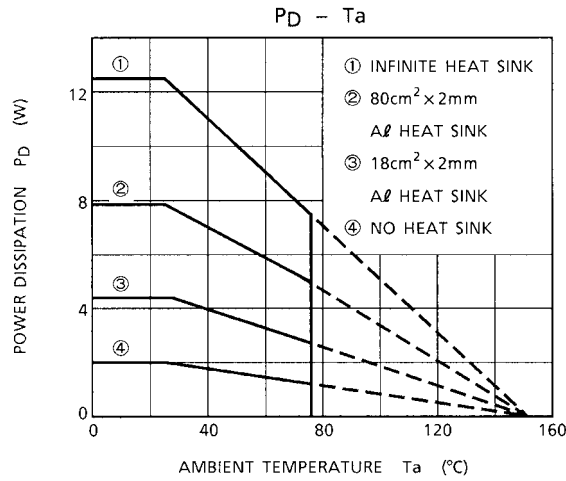

APPLICATION CIRCUIT 1

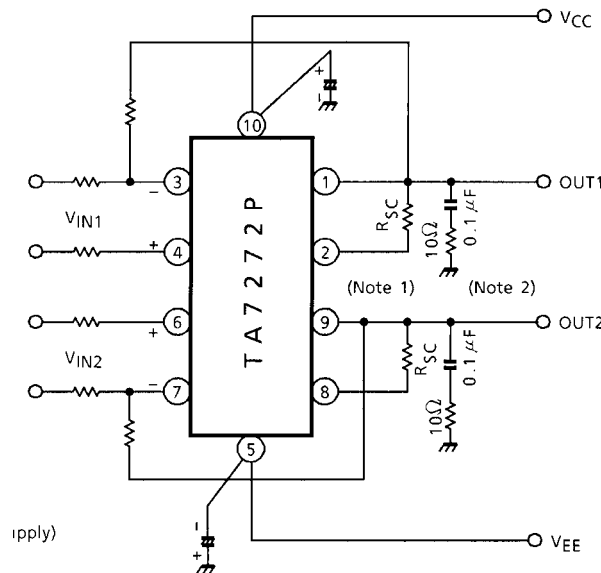

Note 1: $I_{SC} \approx \frac{0.7(V)}{R_{SC}(\Omega)}$ (A)

Note 2: When crossover distortion becomes, noticeable at frequencies higher than 80 kHz, change the value of the capacitor, which functions as a compensating circuit, to about 0.33 μF, In this case, resistor is not needed.

APPLICATION CIRCUIT 2 (Actuator)

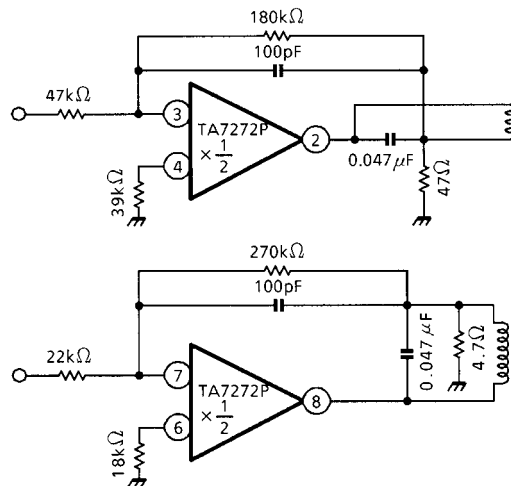

APPLICATION CIRCUIT 3 (Speed and carriage control)

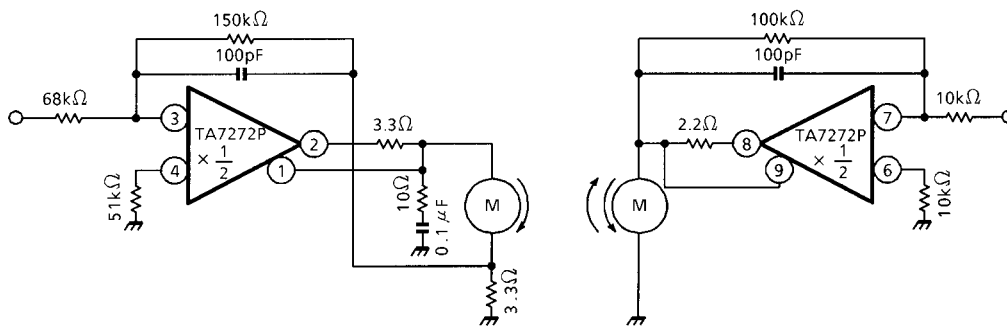

Note: Utmost care is necessary in the design of the output line, V_{CC} , V_{EE} and GND line since IC may be destroyed due to short-circuit between outputs, air contamination fault, or fault by improper grounding.

PACKAGE DIMENSIONS

HSIP10-P-2.54

Unit: mm

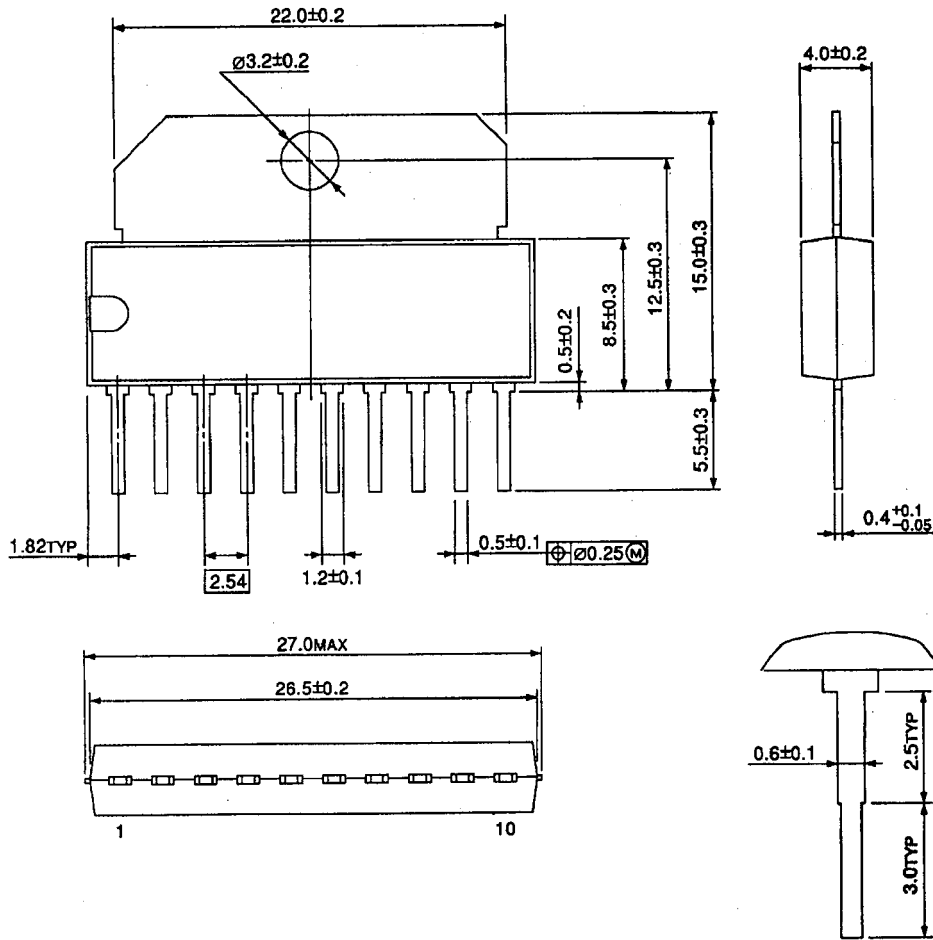

Weight: 2.47 g (Typ.)

RESTRICTIONS ON PRODUCT USE

000707EBA

- TOSHIBA is continually working to improve the quality and reliability of its products. Nevertheless, semiconductor devices in general can malfunction or fail due to their inherent electrical sensitivity and vulnerability to physical stress. It is the responsibility of the buyer, when utilizing TOSHIBA products, to comply with the standards of safety in making a safe design for the entire system, and to avoid situations in which a malfunction or failure of such TOSHIBA products could cause loss of human life, bodily injury or damage to property.
In developing your designs, please ensure that TOSHIBA products are used within specified operating ranges as set forth in the most recent TOSHIBA products specifications. Also, please keep in mind the precautions and conditions set forth in the "Handling Guide for Semiconductor Devices," or "TOSHIBA Semiconductor Reliability Handbook" etc..
- The TOSHIBA products listed in this document are intended for usage in general electronics applications (computer, personal equipment, office equipment, measuring equipment, industrial robotics, domestic appliances, etc.). These TOSHIBA products are neither intended nor warranted for usage in equipment that requires extraordinarily high quality and/or reliability or a malfunction or failure of which may cause loss of human life or bodily injury ("Unintended Usage"). Unintended Usage include atomic energy control instruments, airplane or spaceship instruments, transportation instruments, traffic signal instruments, combustion control instruments, medical instruments, all types of safety devices, etc.. Unintended Usage of TOSHIBA products listed in this document shall be made at the customer's own risk.
- The products described in this document are subject to the foreign exchange and foreign trade laws.
- The information contained herein is presented only as a guide for the applications of our products. No responsibility is assumed by TOSHIBA CORPORATION for any infringements of intellectual property or other rights of the third parties which may result from its use. No license is granted by implication or otherwise under any intellectual property or other rights of TOSHIBA CORPORATION or others.
- The information contained herein is subject to change without notice.