

FM FRONT END IC

The TA7378P is low operation voltage FM FRONT END IC for the portable equipments which are suitable for the headphone stereo radios and radio cassette players.

It is available TV band frequency (VHF).

- Built-in Varicap Diode for AFC
- Wide Supply Voltage Range: $V_{CC}=1.6\sim 6.0V$ ($T_a=25^\circ C$)
- Excellent Supply Voltage Dependence of Local Oscillator : Oscillation Stop $V_{CC}=0.9V$ (Typ.)
- Improved Inter-Modulation Characteristics by Double Balanced Type Mixer Circuit.
- Built-in Clamping Diode for the Local Oscillator Output.

MAXIMUM RATINGS ($T_a=25^\circ C$)

CHARACTERISTIC	SYMBOL	RATING	UNIT
Supply Voltage	V_{CC}	8	V
Power Dissipation (Note)	P_D	500	mW
Operating Temperature	T_{opr}	-25~75	$^\circ C$
Storage Temperature	T_{stg}	-55~150	$^\circ C$

Note: Derated above $T_a=25^\circ C$ in the proportion of $4mW/^\circ C$.

BLOCK DIAGRAM

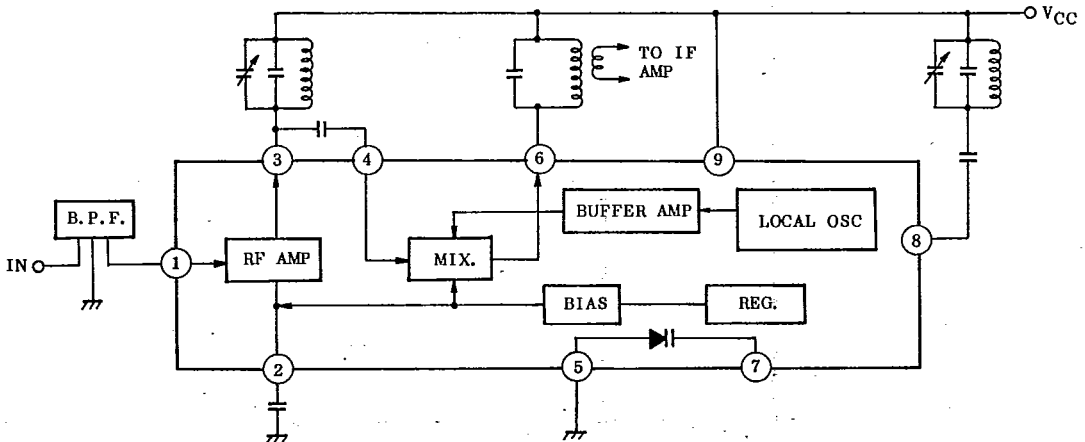

Unit in mm

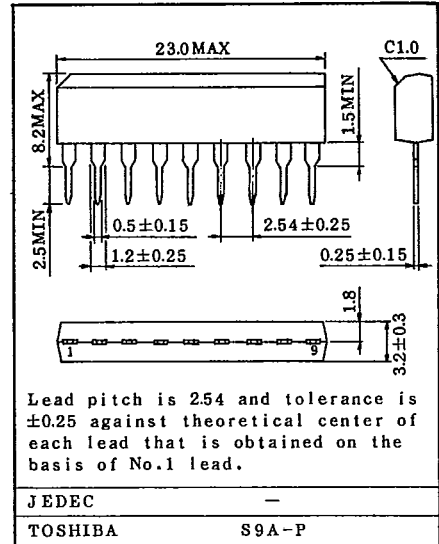

Lead pitch is 254 and tolerance is ± 0.25 against theoretical center of each lead that is obtained on the basis of No.1 lead.

JEDEC

TOSHIBA

S9A-P

Weight : 0.92g

ELECTRICAL CHARACTERISTICS

(Unless otherwise specified, $V_{CC}=5V$, $f=83MHz$, $f_m=1kHz$, $\Delta f=\pm 2.5kHz$ dev., $T_a=25^\circ C$)

CHARACTERISTIC		SYMBOL	TEST CIRCUIT	TEST CONDITION	MIN.	TYP.	MAX.	UNIT
Supply Current		I_{CC}	2	$V_{IN}=0$	-	5.2	8.0	mA
-3dB Limiting Sensitivity		$V_{IN}(1\mu m)$	2		-	3.0	7.0	$dB\mu$
Quiescent Sensitivity		Q_S	2		-	11.0	-	$dB\mu$
Conversion Gain		G_C	-		-	31	-	dB
Local OSC Voltage		V_{OSC1}	1	$f_{OSC}=60MHz$	340	440	560	mV_{rms}
		V_{OSC2}	1	$f_{OSC}=215MHz$	-	120	-	
1 Pin Impedance	Parallel Input Resistance	r_{ip1}	3	$f=83MHz$	-	57	-	Ω
3 Pin Impedance	Parallel Output Resistance	r_{op3}	3		-	25	-	$k\Omega$
	Parallel Output Capacitance	c_{op3}			-	2.0	-	pF
4 Pin Impedance	Parallel Input Resistance	r_{ip4}	3		-	2.7	-	$k\Omega$
	Parallel Input Capacitance	c_{ip4}			-	3.3	-	pF
6 Pin Impedance	Parallel Output Resistance	r_{op6}	3		$f=10.7MHz$	-	100	-
	Parallel Output Capacitance	c_{op6}		-		4.8	-	pF
Local OSC Stop Voltage		V_{stop}	1		-	0.9	1.3	V

ELECTRICAL CHARACTERISTICS

DC CHARACTERISTICS ($V_{CC}=5V$, $T_a=25^\circ C$, Terminal Voltage at No Signal)

ITEM	SYMBOL	TYPICAL VALUE	UNIT
1 Pin (RF IN)	V1	0.8	V
2 Pin (BY PASS)	V2	1.5	V
3 Pin (RF OUT)	V3	5.0	V
4 Pin (MIX IN)	V4	1.5	V
5 Pin (AFC DIODE ANODE)	V5	0	V
6 Pin (MIX OUT)	V6	5.0	V
7 Pin (AFC DIODE CATHODE)	V7	-	V
8 Pin (OSC)	V8	5.0	V
9 Pin (V_{CC})	V9	5.0	V

TEST CIRCUIT 1 : VOSC

Q1 : FM BAND 2SC1923
 (h_{fe} Rank ... 0)
 TV BAND 2SC2499
 (h_{fe} Rank ... 0)

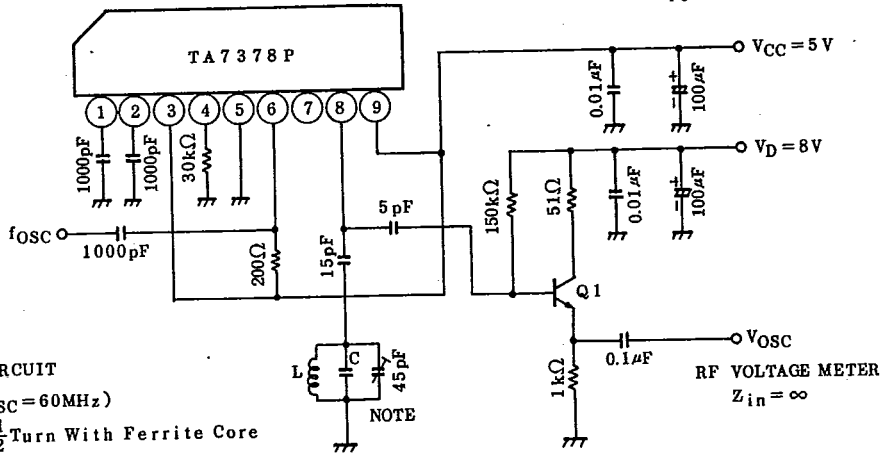

NOTE : TANK CIRCUIT

FM BAND (f_{OSC}=60MHz)

L : 5mm∅, 2 1/2 Turn With Ferrite Core

C : 45pF (Trima Condenser)
 + 36pF by Parallel

TV BAND (f_{OSC}=215MHz)

L : 5mm∅, 3 Turn Without Ferrite Core

C : 45 pF (Trima Condenser)

TEST CIRCUIT 2

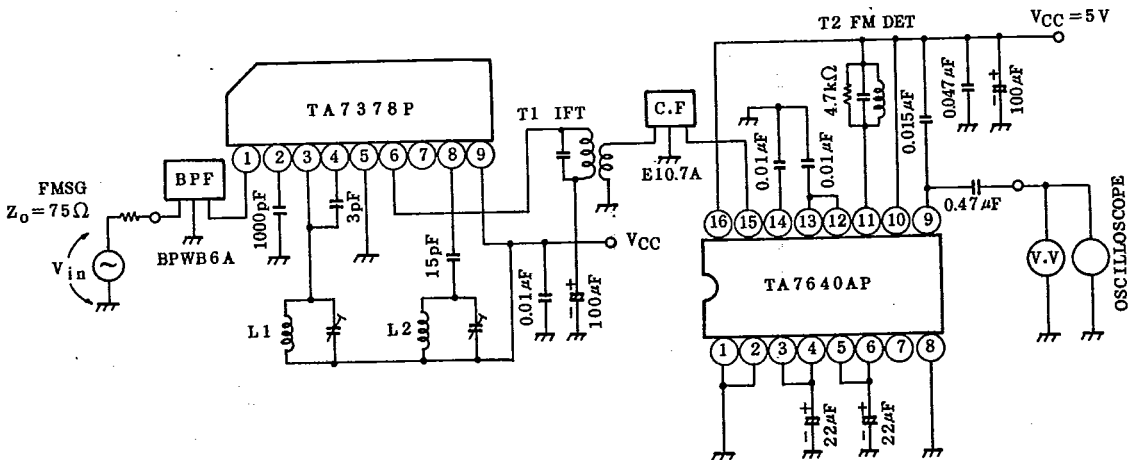

TEST CIRCUIT 3

① Pin INPUT r_{ip1} , c_{ip1}

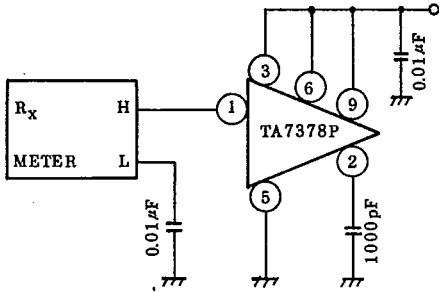

③ Pin OUTPUT r_{op3} , c_{op3}

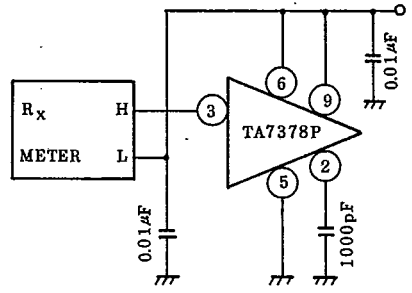

④ Pin INPUT r_{ip4} , c_{ip4}

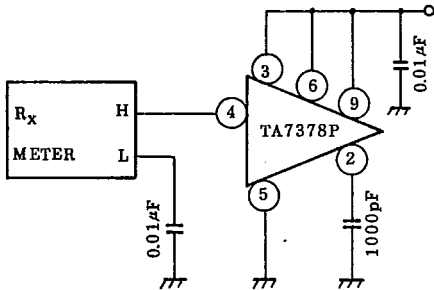

⑥ Pin OUTPUT r_{op6} , c_{op6}

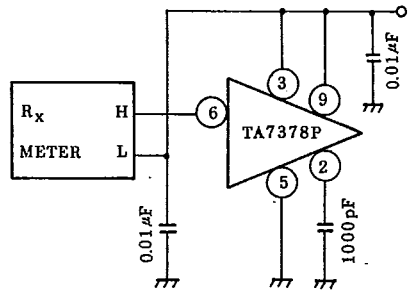

AFC DIODE C_{AFC}

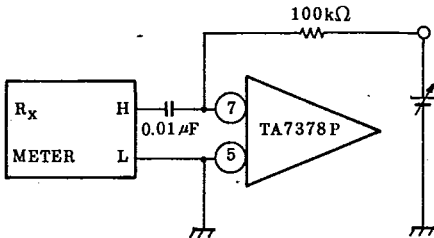

COIL DATA FOR TEST CIRCUIT

COIL No.	TEST FREQUENCY	L (μ H)	C ₀ (pF)	Q ₀	TURN				NOTE
					1-2	2-3	1-3	4-6	
L1 FM RF	100MHz			100			(2 $\frac{1}{4}$)		JAPAN BAND
L2 FM OSC	100MHz			100			(2 $\frac{1}{2}$)		JAPAN BAND
T1 FM IFT	10.7MHz		75	115			12	1	⑤ 0133-309-048
T2 FM DET	10.7MHz		47	150				14	⑤ 44M-037-933A

⑤ SUMIDA ELECTRIC CO., LTD

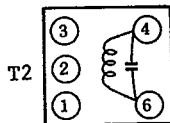
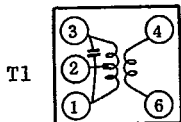

$V_{OD}, V_{NO}, THD, AMR - V_{IN}$

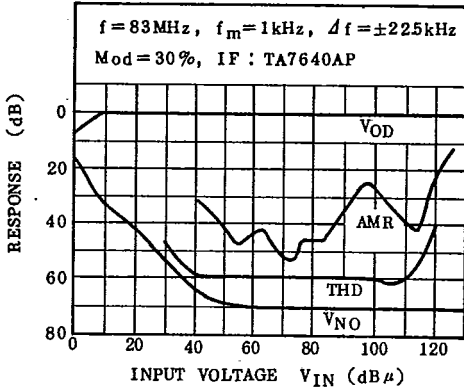

$V_{OSC}, f_{osc} - V_{CC}$

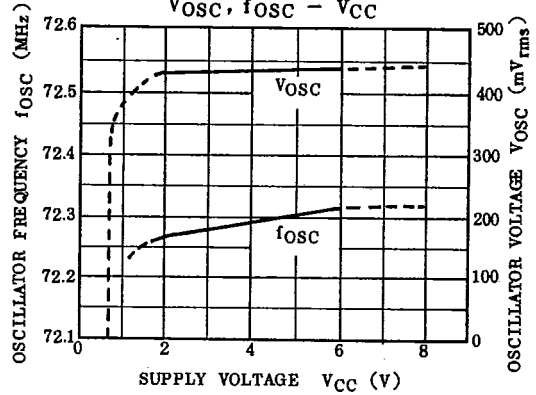

$I_{CC} - V_{CC}$

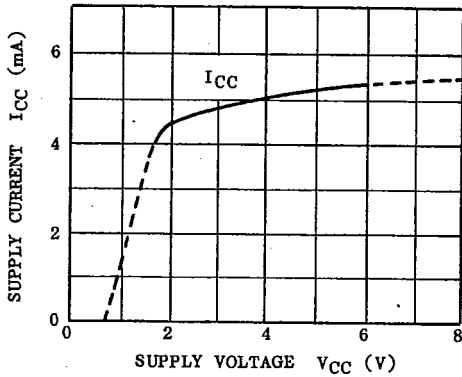

$V_{IN}(lim), Q_S - V_{CC}$

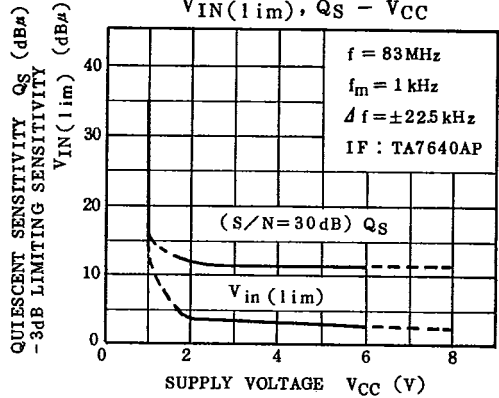

$C_{AFC} - V_{AFC}$

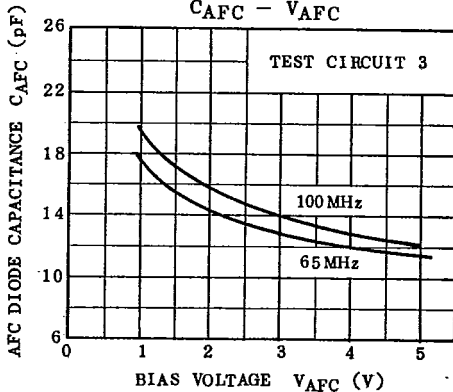

AM/FM STEREO TUNER APPLICATION CIRCUIT

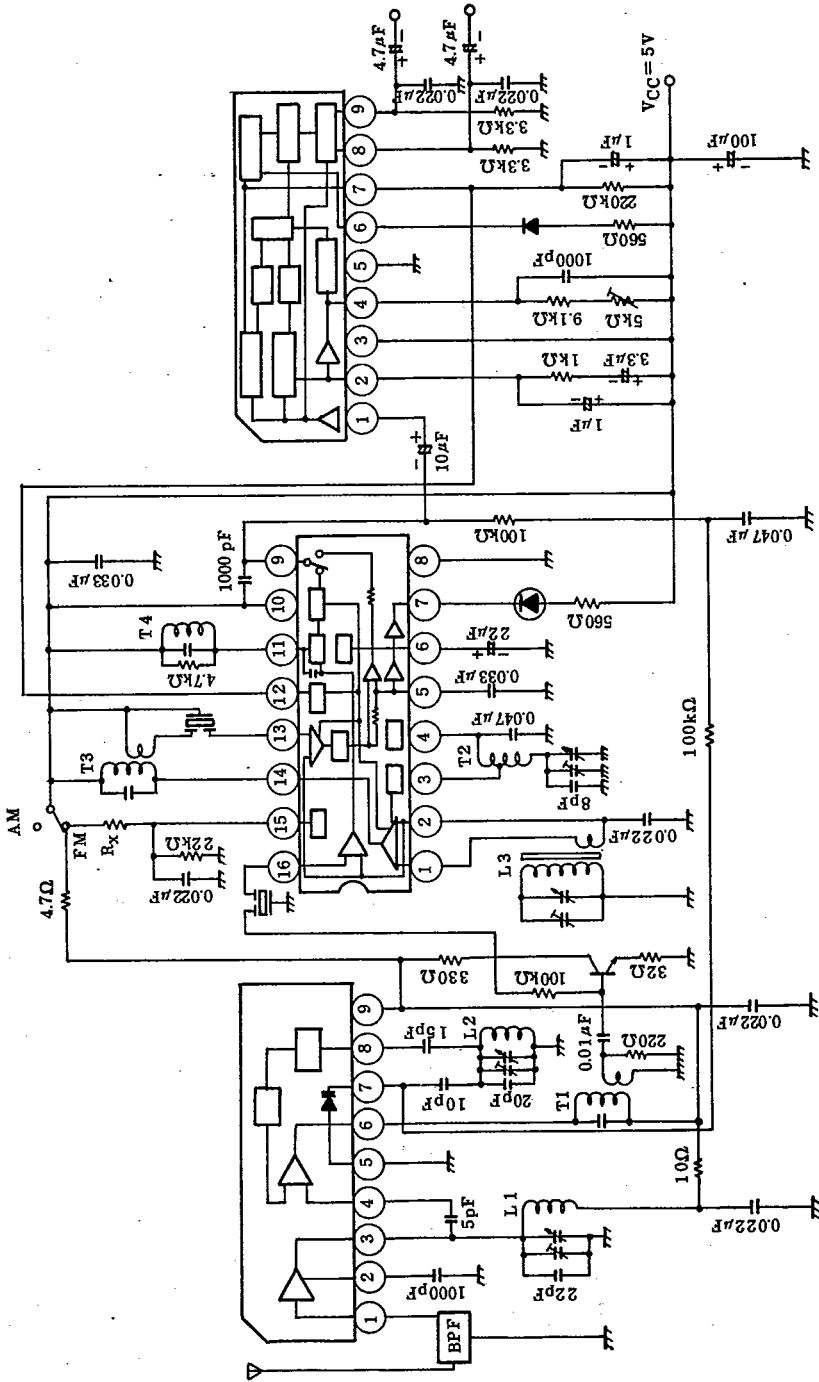

TA7343AP

TA8110AF

TA7378P

COIL DATA FOR APPLICATION CIRCUIT

COIL No.	STAGE	TEST FREQ.	L (μ H)	Co (pF)	Qo	TURNS				WIRE (mm)	REMARKS
						①-②	②-③	③-④	④-⑤		
L1	FM RF	100MHz	0.07		100			$1\frac{1}{4}$		0.5 ϕ UEW	Within Core
L2	FM OSC	100MHz	0.05		100			$1\frac{3}{4}$		0.5 ϕ UEW	Within Core
L3	MW ANT	796kHz	600		200	99			17	0.07 ϕ ×3 USTC	Core 10 ϕ × 80mm
T1	FM IFT	10.7MHz		82	90		11		2	0.16 ϕ UEW	MITUMI YT-20580 SUMIDA 2153-414-041
T2	MW OSC	796kHz	268		125	15	89			0.16 ϕ UEW	SUMIDA 2157-2239-213A (5388)
T3	AM MIX	455kHz		330	115		132	9		0.16 ϕ UEW	SUMIDA S193-006 (4837)
T4	FM DET	10.7MHz		47	165		16			0.09 ϕ UEW	SUMIDA S193-008 (5822)

CONNECTION (BOTTOM VIEW)

