

DUAL PRE AMPLIFIER SYSTEM

The TA7417AP is a dual preamplifier system IC designed for radio cassette player of the low end class to the middle class.

- . Recording Amp with ALC
- . Play Back Amp
- . Mic Amp with ALC
- . Monitor Amp
- . Built-in switch for selecting REC/PLAY
- . Built-in switch for selecting TAPE input or RADIO(AUX) input
- . Built-in Recording Bias Circuit Control terminal
- . Following 4 modes can be carried out by external two switches combination.
 - . Radio Recording
 - . Mic Recording
 - . Radio Play
 - . Tape Play Back
- . Few external parts
- . Small package (ZIP-21)
- . Operational supply voltage (recommended)

$V_{CC}=3.5 \sim 7V$ ($T_a=25^\circ C$)

Unit in mm

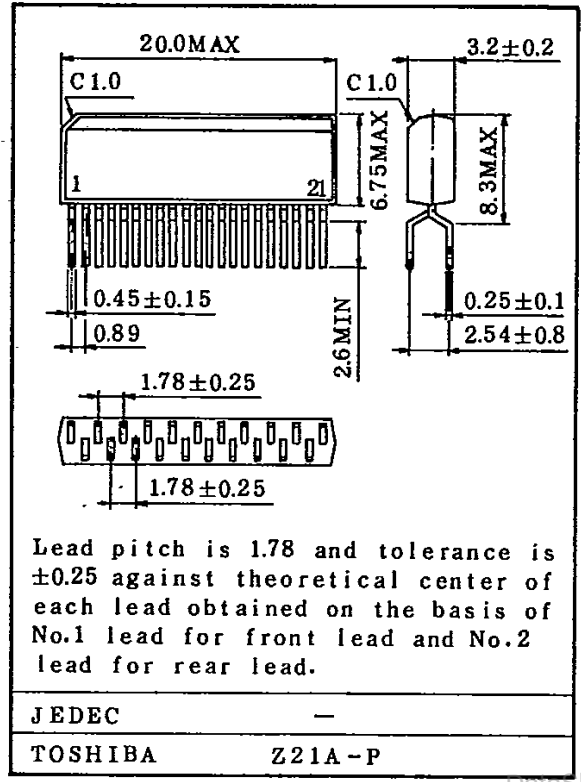

Lead pitch is 1.78 and tolerance is ± 0.25 against theoretical center of each lead obtained on the basis of No.1 lead for front lead and No.2 lead for rear lead.

Weight : 0.94g

MAXIMUM RATINGS ($T_a=25^\circ C$)

CHARACTERISTIC	SYMBOL	RATING	UNIT
Supply Voltage	V_{CC}	8	V
Power Dissipation (Note)	PD	750	mW
Operating Temperature	T_{opr}	-25~75	$^\circ C$
Storage Temperature	T_{stg}	-55~150	$^\circ C$

Note: Derated above $T_a=25^\circ C$ in the proportion of 6mW/ $^\circ C$.

ELECTRICAL CHARACTERISTICS (Unless otherwise specified, $T_a=25^{\circ}\text{C}$, $V_{CC}=5\text{V}$, $f=1\text{kHz}$)

CHARACTERISTIC		SYMBOL	TEST CONDITION	MIN.	TYP.	MAX.	UNIT
Quiescent Current		ICC1	S1=RADIO, S2=PLAY	-	11	16	mA
		ICC2	S1=RADIO, S2=REC	-	14	19	
		ICC3	S1=TAPE, S2=PLAY	-	11	16	
		ICC4	S1=TAPE, S2=REC	-	10	15	
Reference Voltage		Vref		1.8	2.0	2.3	V
MONITOR AMP	Voltage Gain	Gv1	Vin=-50dBV	14	16	18	dB
	Maximum Output Voltage	Vomax1	THD=1%	-	1.3	-	Vrms
	Output Noise Voltage	Vno1	BW=5~30kHz	-	15	-	μVrms
	Total Harmonic Distortion	THD1	Vout=-10dBV, BW=400~30kHz	-	0.06	-	%
	Cross Talk	CT1	Vout=0dBV, BW=400~30kHz	-	-66	-	dB
	Ripple Rejection Ratio	RR1	Vripple=-20dBV, f=100Hz	-	-50	-	dB
PLAY BACK AMP	Voltage Gain	Gv2	Vin=-50dBV	35	38	41	dB
	Open Loop Voltage Gain	Gvo2	Vin=-90dBV	-	78	-	dB
	Maximum Output Voltage	Vomax2	THD=1%	-	1.3	-	Vrms
	Output Noise Voltage	Vno2	BW=5~30kHz	-	80	160	μVrms
	Total Harmonic Distortion	THD2	Vout=-10dBV, BW=400~30kHz	-	0.02	-	%
	Cross Talk	CT2	Vout=0dBV, BW=400~30kHz	-	-77	-	dB
	Ripple Rejection Ratio	RR2	Vripple=-20dBV, f=100Hz	-	-42	-	dB
REC AMP	Voltage Gain	Gv3	Vin=-50dBV	24	27	30	dB
	Output Noise Voltage	Vno3	BW=5~30kHz	-	160	-	μVrms
	Total Harmonic Distortion	THD3	Vout=-10dBV, BW=400~30kHz	-	0.04	-	%
	Cross Talk	CT3	Vout=-10dBV, BW=400~30kHz	-	-71	-	dB
	Ripple Rejection	RR3	Vripple=-20dBV, f=100Hz	-	-42	-	dB
	ALC1	ALC31	Vin=-25dBV, Dual OP.	-6	-2	2	dBV
	ALC2	ALC32	Vin=-15dBV, Dual OP.	-	-1	-	dBV
	ALC3	ALC33	Vin=-5dBV, Dual OP.	-	-1	-	dBV
MIC AMP+REC AMP	Voltage Gain	Gv4	Vin=-80dBV	-	63	-	dB
	Output Noise Voltage	Vno4	BW=5~30kHz	-	3.5	5.6	mVrms
	Total Harmonic Distortion	THD4	Vout=-10dBV, BW=400~30kHz	-	0.7	-	%
	Cross Talk	CT4	Vout=-10dBV, BW=400~30kHz	-	-43	-	dB
	Ripple Rejection Ratio	RR4	Vripple=-20dBV, f=100Hz	-	-28	-	dB
	ALC1	ALC41	Vin=-60dBV, Dual OP.	-6	-2	2	dBV
	ALC2	ALC42	Vin=-40dBV, Dual OP.	-	-1	-	dBV
	ALC3	ALC43	Vin=-15dBV, Dual OP.	-4	-1	2	dBV

TA7417AP

BLOCK DIAGRAM

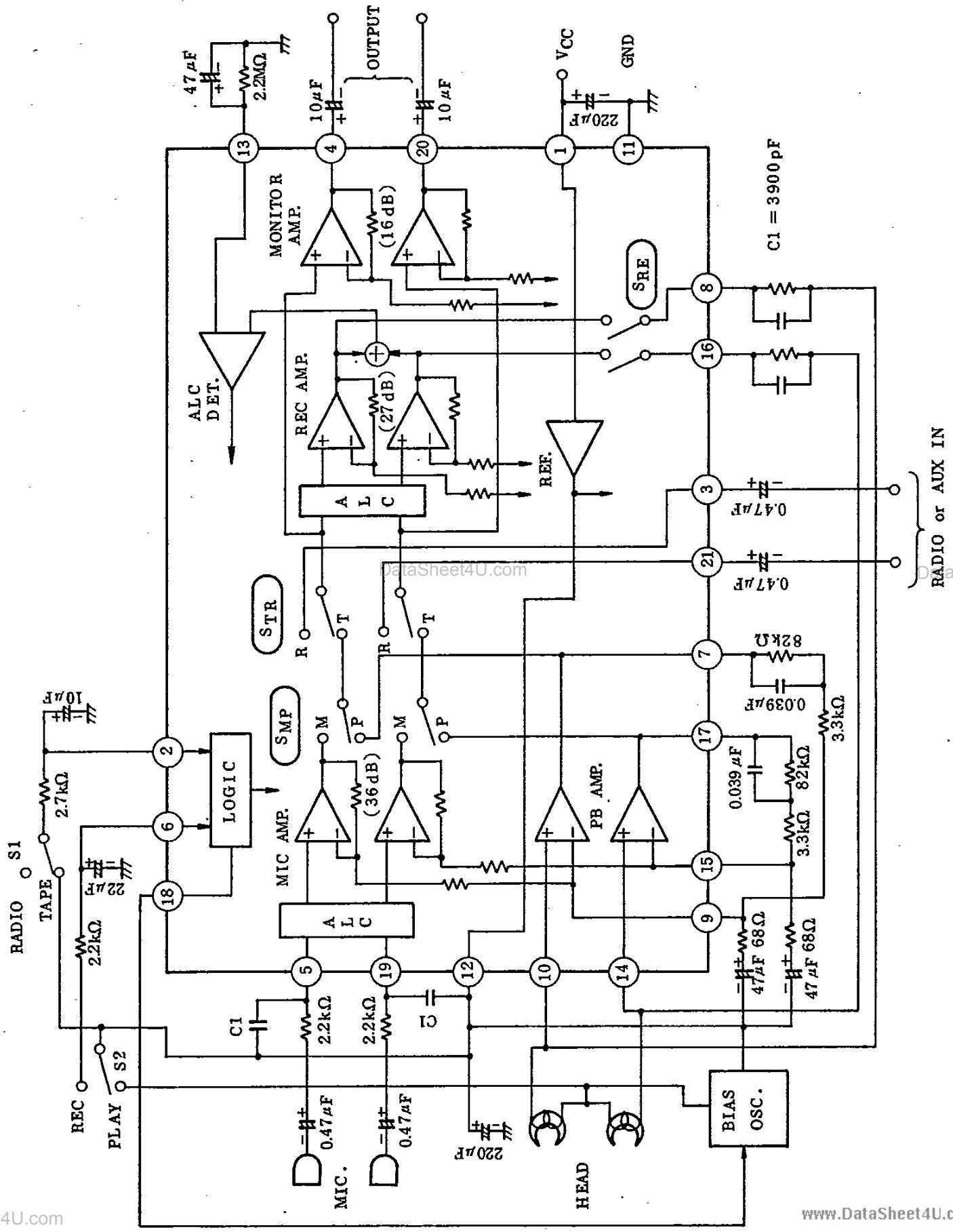

TEST CIRCUIT

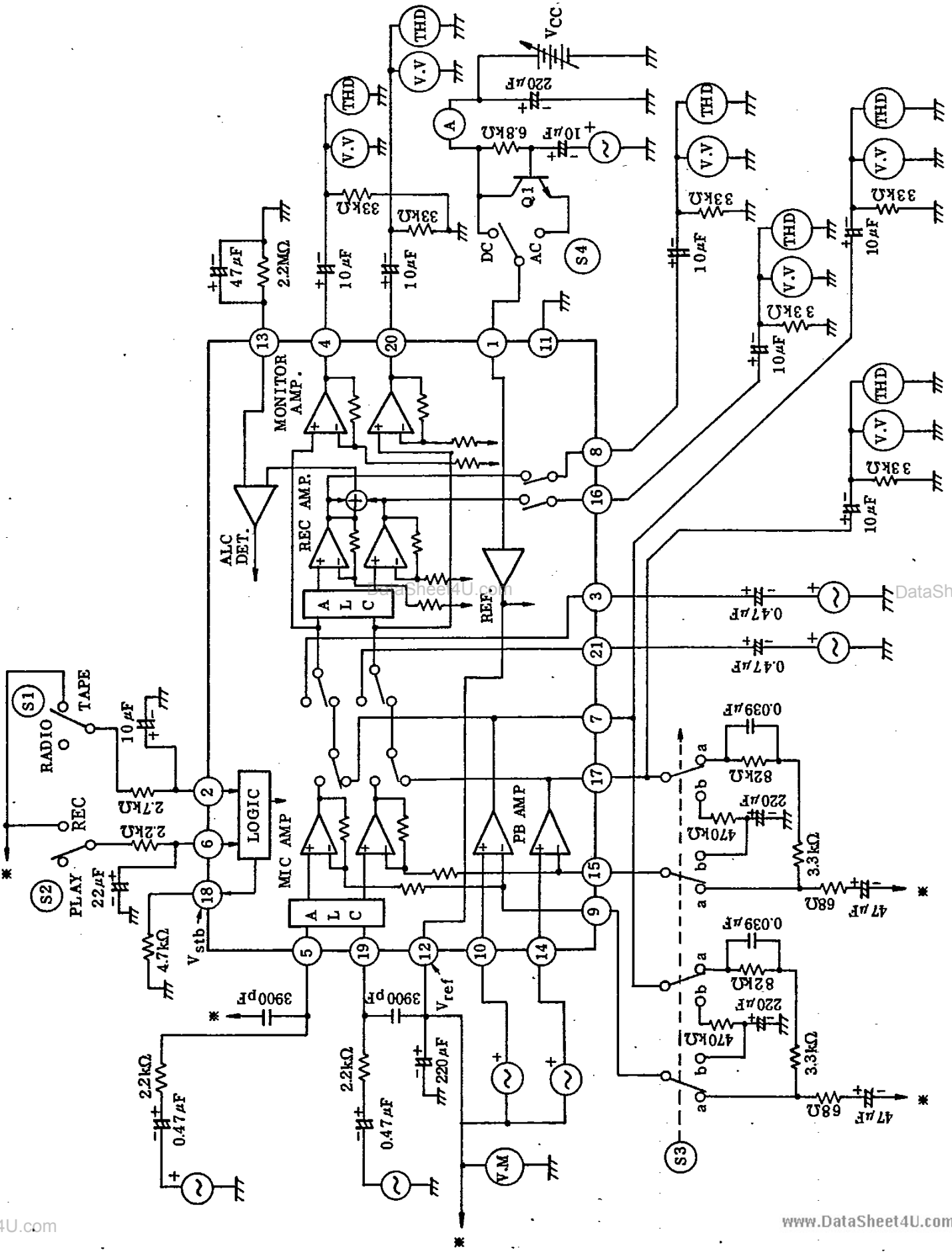

TEST METHOD (cf TEST CIRCUIT)

SYMBOL	S1	S2	S3	S4
ICC1	RADIO	PLAY	a	DC
ICC2	RADIO	REC	↓	↓
ICC3	TAPE	PLAY	↓	↓
ICC4	TAPE	REC	↓	↓
Vref	-	-	↓	↓
Gv1	RADIO	REC	a	DC
Vo max1	↓	↓	↓	↓
Vno1	↓	↓	↓	↓
THD1	↓	↓	↓	↓
CT1	↓	↓	↓	↓
RR1	RADIO	REC	a	AC
Gvo2	TAPE	PLAY	b	DC
Gv2	TAPE	PLAY	a	DC
Vo max2	↓	↓	↓	↓
Vno2	↓	↓	↓	↓
THD2	↓	↓	↓	↓
CT2	↓	↓	↓	↓
RR2	TAPE	PLAY	a	AC

SYMBOL	S1	S2	S3	S4
Gv3	RADIO	REC	a	DC
Vno3	↓	↓	↓	↓
THD3	↓	↓	↓	↓
CT3	↓	↓	↓	↓
RR3	RADIO	REC	a	AC
ALC31	RADIO	REC	a	DC
ALC32	↓	↓	↓	↓
ALC33	↓	↓	↓	↓
Gv4	TAPE	REC	a	DC
Vno4	↓	↓	↓	↓
THD4	↓	↓	↓	↓
CT4	↓	↓	↓	↓
RR4	TAPE	REC	a	AC
ALC41	TAPE	REC	a	DC
ALC42	↓	↓	↓	↓
ALC43	↓	↓	↓	↓

DESCRIPTION OF EACH TERMINAL

TERMINAL No.	TERMINAL NAME	FUNCTION	EQUIVALENT CIRCUIT
1	VCC	VCC	—
2	TAPE/RADIO SW	Change over switch for tape mode and radio mode. Tape mode: Tape play MIC REC Radio mode: Radio play Radio REC	
3/21	RADIO (AUX) IN	Radio or Aux. input	
4/20	MONITOR OUT	Monitor Amp output	
5/19	MIC IN	MIC Amp input	

DESCRIPTION OF EACH TERMINAL

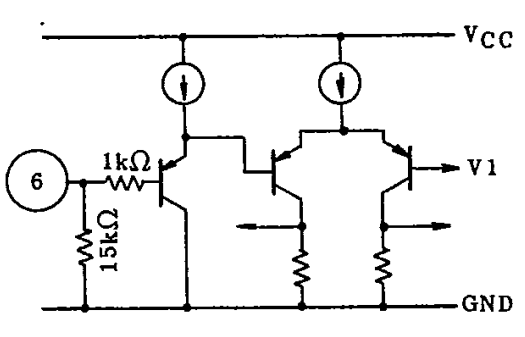
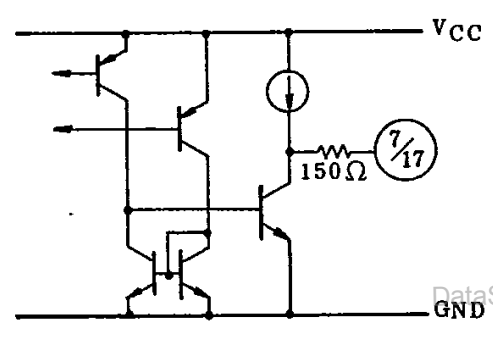
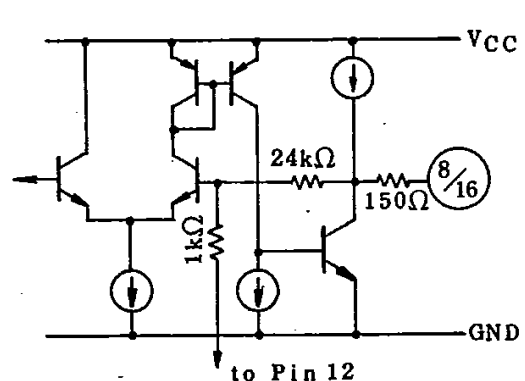
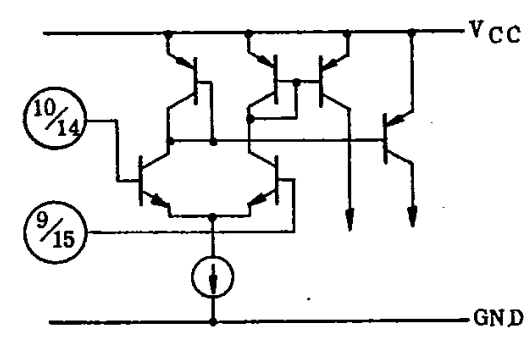
TERMINAL No.	TERMINAL NAME	FUNCTION	EQUIVALENT CIRCUIT
6	REC/PLAY SW	Change over switch for REC mode and play mode REC mode : MIC REC Radio REC Play mode: Tape play Radio play	
7/17	TAPE OUT	Tape play back Amp (PB AMP) output	
8/16	REC OUT	Recording Amp output	
9/15	PB NF	Tape play back Amp (PB AMP) NF	

DESCRIPTION OF EACH TERMINAL

TERMINAL No.	TERMINAL NAME	FUNCTION	EQUIVALENT CIRCUIT
10/14	TAPE IN	Tape play back Amp (PB AMP) input	
11	GND	GND	—
12	REFERENCE	Reference voltage terminal	
13	AGC T.C	Automatic level control (ALC) time constant terminal	
18	V _{stb}	Recording bias circuit control signal output	

OPERATION MODE BY EXTERNAL SWITCHES (S1,S2) COMBINATION

CIRCUIT BLOCK	S2	S2 = REC		S2 = PLAY	
	S1	S1=RADIO	S1=TAPE	S1=RADIO	S1=TAPE
MIC AMP		ON	ON	OFF	OFF
PB AMP		OFF	OFF	ON	ON
REC AMP		ON	ON	OFF	OFF
MONITOR AMP		ON	OFF	ON	ON
SMP		M	M	P	P
STR		R	T	R	T
SRE		ON	ON	OFF	OFF
OPERATION MODE		RADIO RECORDING	MIC RECORDING	RADIO PLAY	TAPE PLAY BACK

CONTROL SWITCH TERMINAL (2,6pin) THRESHOLD VOLTAGE

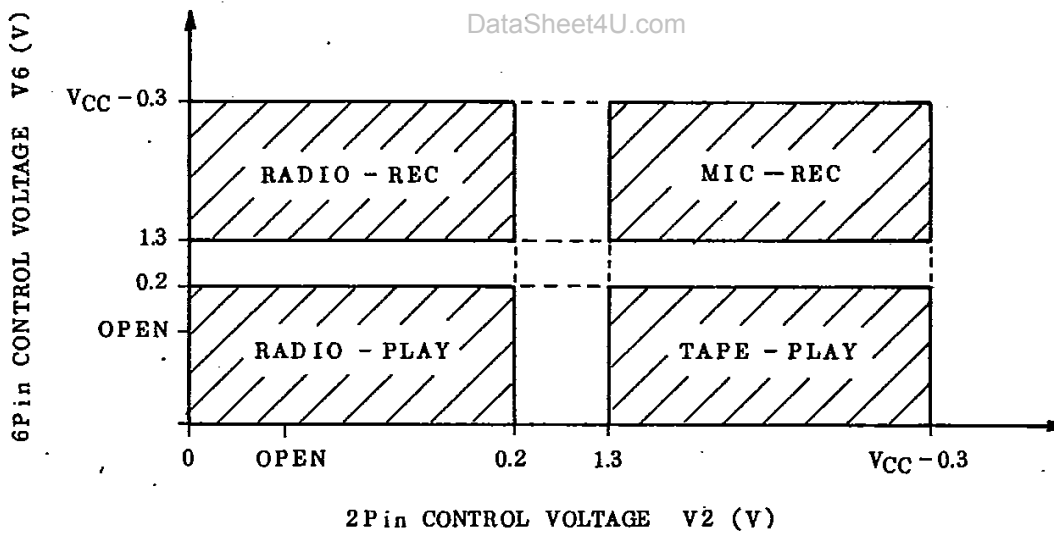

OPERATION IN EACH MODE

(1) RADIO-REC MODE

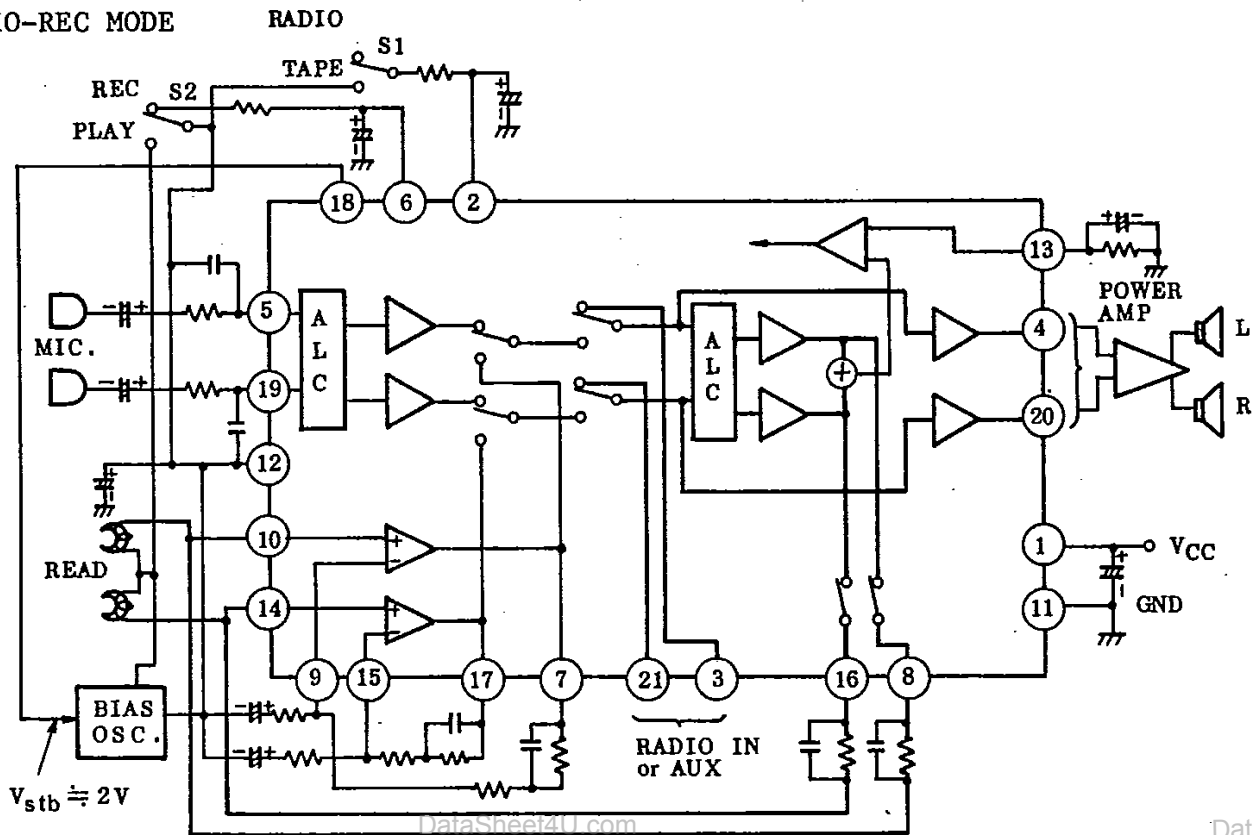

(2) RADIO-PLAY MODE

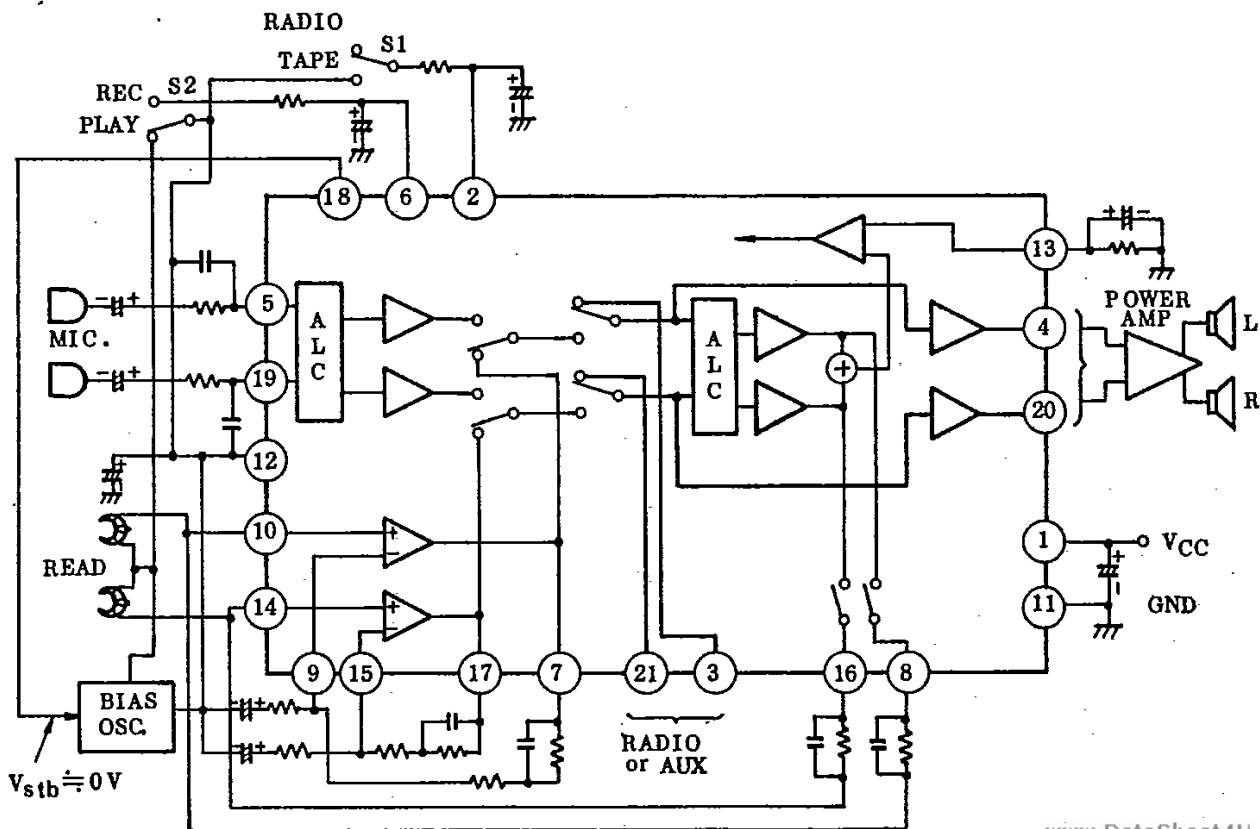

TA7417AP

(3) MIC-REC MODE

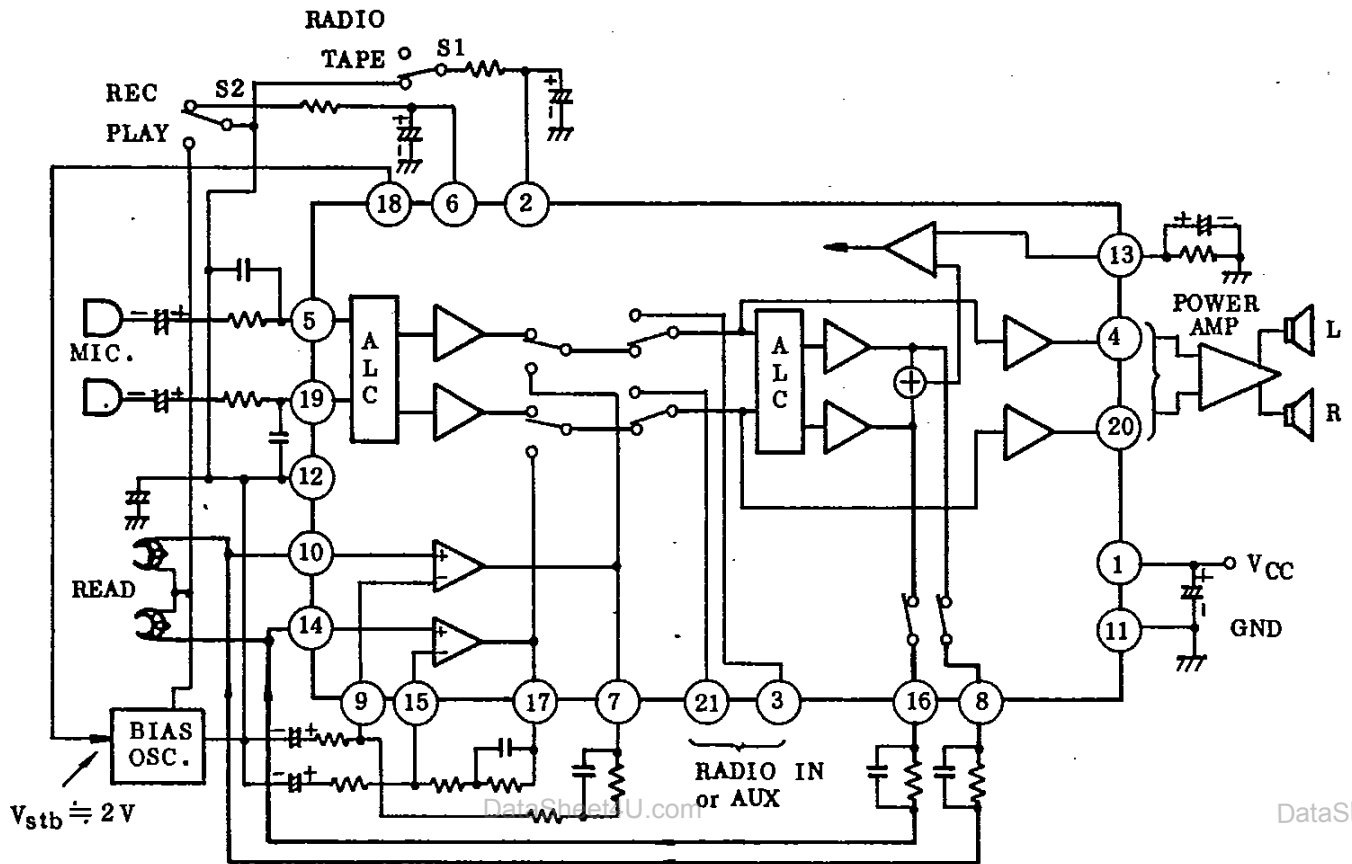

(4) TAPE-PLAY MODE

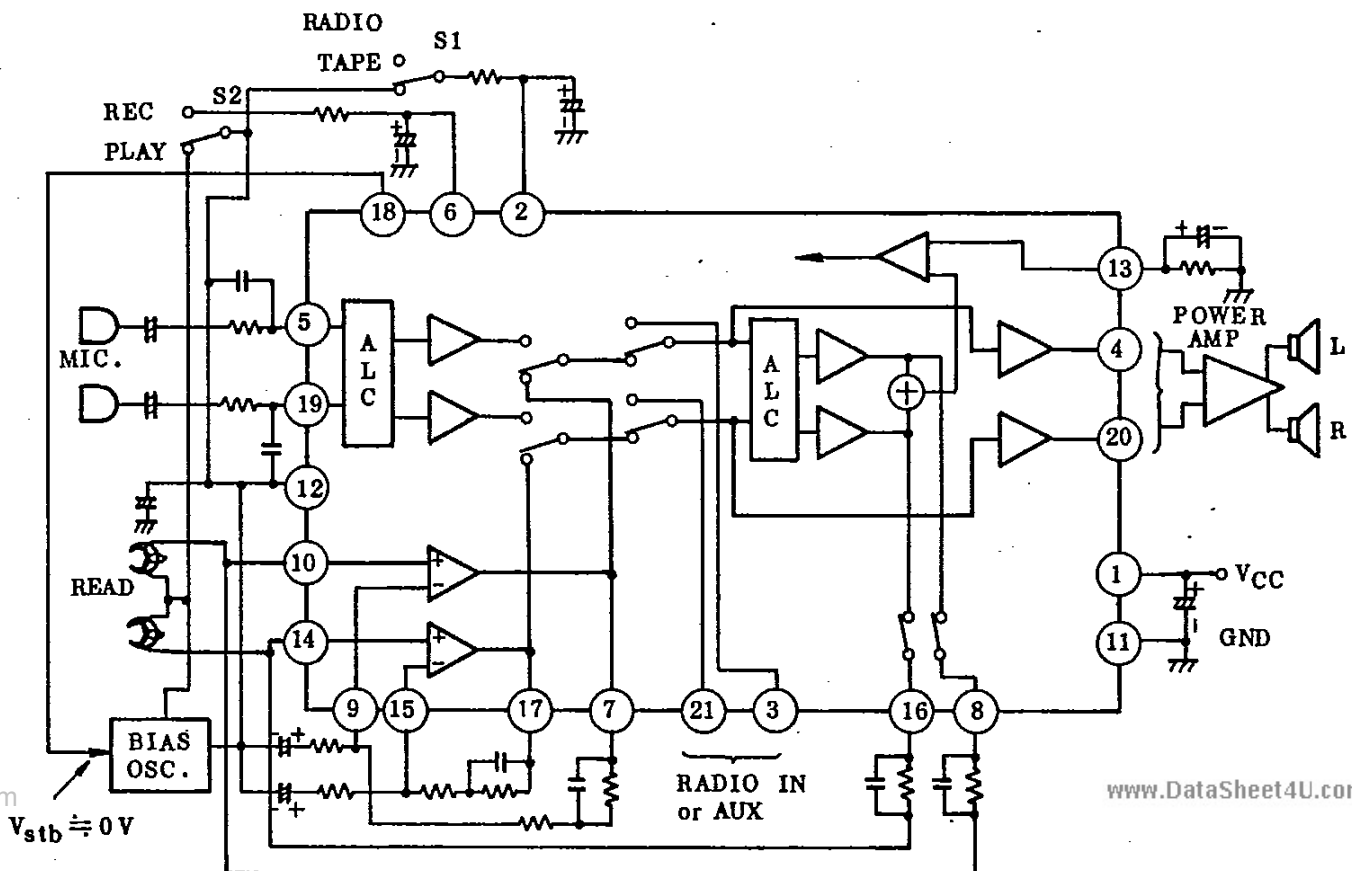

DESCRIPTION OF BIAS OSC. CONTROL TERMINAL (18 pin).

The equivalent circuit of 18 pin is shown in Fig. 1.

When this IC is in the REC MODE (RADIO REC or MIC REC), the switch S_a is in the "ON" state and the DC voltage 2.05V(Typ.) appears in this terminal.

The output current value of this terminal should be under $300\mu\text{A}$.

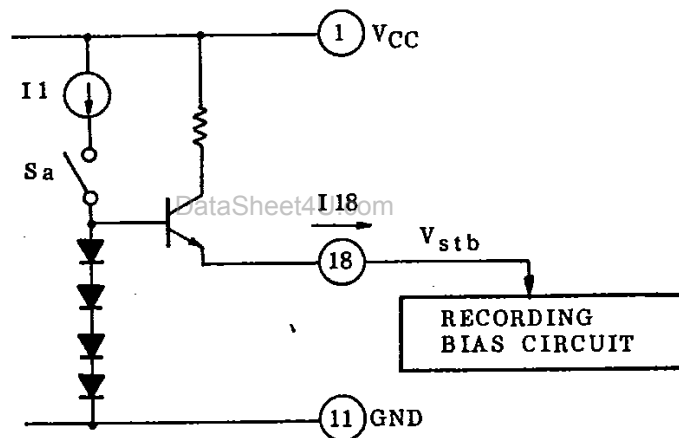

Fig. 1

