

TOSHIBA BIPOLAR LINEAR INTEGRATED CIRCUIT SILICON MONOLITHIC

TA75559P, TA75559S, TA75559F**DUAL OPERATIONAL AMPLIFIER**

The TA75559P, TA75559S and TA75559F are Low-Noise Operational Amplifiers with High Speed and Wide Bandwidth.

It is Wide Bandwidth with Frequency Characteristic improvement TA75558P, TA75558S and TA75558F.

FEATURES

- Wide Band Decompensated ($A_V \geq 20\text{dB}$)
- Pin Compatible with TA75458P, TA75458S and TA75458F
- Possible to Exchange the Position of 9 Pin for 1 Pin Because of Pin Connection Being Symmetric. (TA75559S Device Only)
- Wide Band Range : $f_T = 5\text{MHz}$ (Typ.)
- Suitable Application for Active Filter, Equalizer Amp. and Headphone Amp.

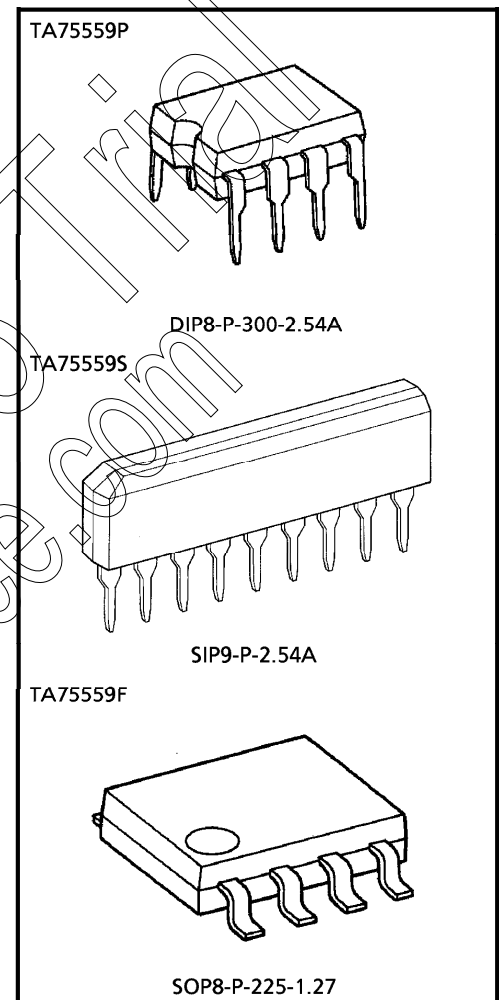

Weight
 DIP8-P-300-2.54A : 0.5g (Typ.)
 SIP9-P-2.54A : 0.9g (Typ.)
 SOP8-P-225-1.27 : 0.1g (Typ.)

PIN CONNECTION (TOP VIEW)

TA75559F

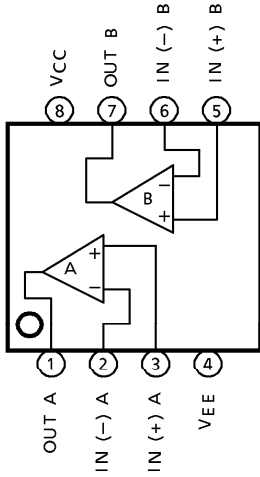

TA75559P

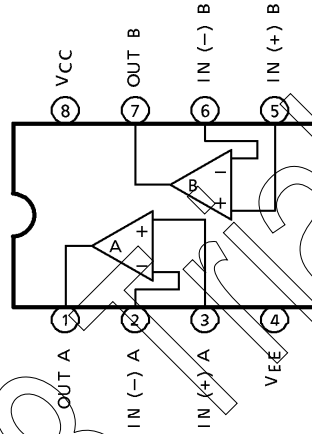

TA75559S

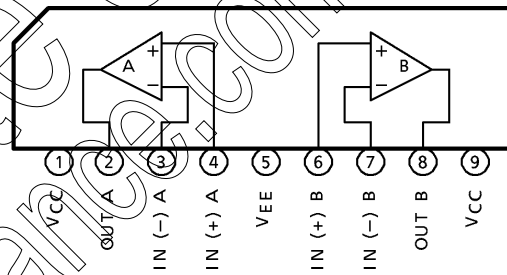

EQUIVALENT CIRCUIT

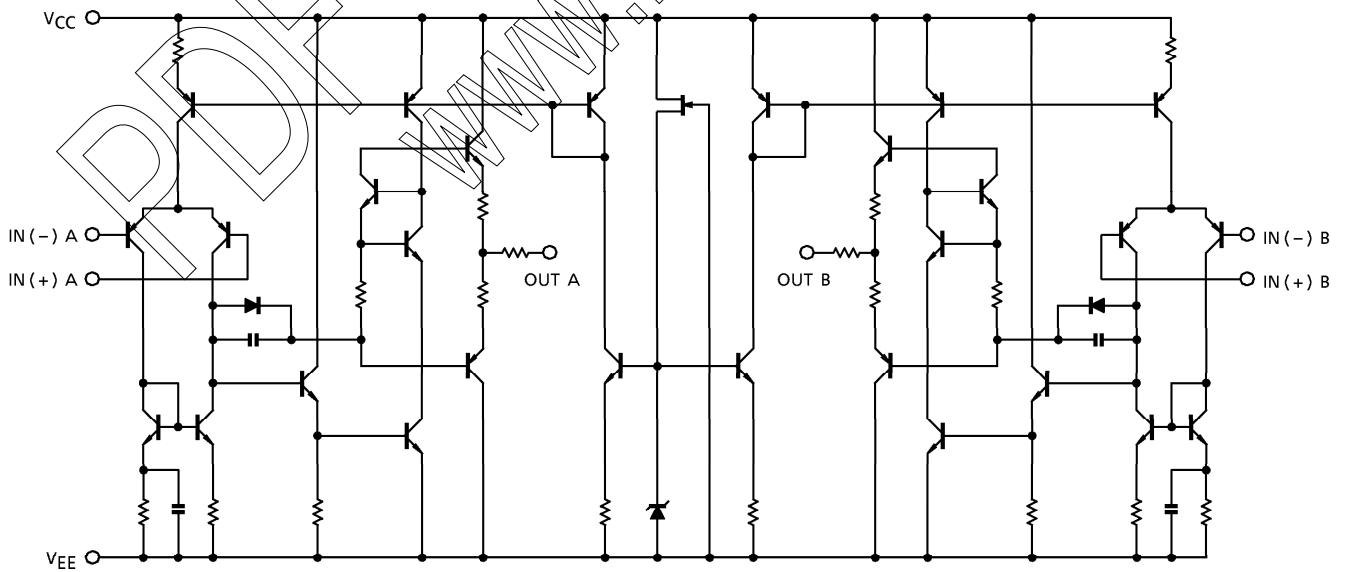

MAXIMUM RATINGS (Ta = 25°C)

CHARACTERISTIC	SYMBOL	TA75559P TA75559S	TA75559F	UNIT
Supply Voltage	V _{CC}	+ 18	+ 18	V
	V _{EE}	- 18	- 18	
Differential Input Voltage	DV _{IN}	± 30	± 30	V
Input Voltage	V _{IN}	V _{CC} ~V _{EE}	V _{CC} ~V _{EE}	V
Power Dissipation	P _D	500	240	mW
Operating Temperature	T _{opr}	- 40~85	- 30~70	°C
Storage Temperature	T _{stg}	- 55~125	- 55~125	°C

ELECTRICAL CHARACTERISTICS (V_{CC} = 15V, V_{EE} = -15V, Ta = 25°C)

CHARACTERISTIC	SYMBOL	TEST CIRCUIT	TEST CONDITION	MIN.	TYP.	MAX.	UNIT
Input Offset Voltage	V _{IO}	1	R _g ≤ 10kΩ	—	0.5	6	mV
Input Offset Current	I _{IO}	2	—	—	5	200	nA
Input Bias Current	I _I	2	—	—	60	500	nA
Common Mode Input Voltage	CMV _{IN}	3	—	± 12	± 14	—	V
Maximum Output Voltage	V _{OM}	6	R _L = 10kΩ	± 12	± 14	—	V
	V _{OMR}		R _L = 2kΩ	± 10	± 13	—	
Source Current	I _{source}	8	—	—	40	—	mA
Sink Current	I _{sink}	7	—	—	40	—	mA
Voltage Gain (Open Loop)	G _V	5	V _{OUT} = ± 10V, R _L = 2kΩ	86	100	—	dB
Common Mode Input Signal Rejection Ratio	CMRR	3	R _g ≤ 10kΩ	70	90	—	dB
Supply Voltage Rejection Ratio	SVRR	1	R _g ≤ 10kΩ	—	30	150	μV/V
Slew Rate	SR	9	G _V = 1, R _L = 2kΩ	—	2.0	—	V/μs
Unity Gain Cross Frequency	f _T	5	Open Loop	—	5.0	—	MHz
Supply Current	I _{CC} , I _{EE}	4	—	—	4.0	6.0	mA
Equivalent Input Noise Voltage	V _{NI}	—	R _S = 1kΩ, f = 30Hz~30kHz	—	2.5	—	μV _{rms}

TEST CIRCUIT

(1) V_{IO} , $SVRR$

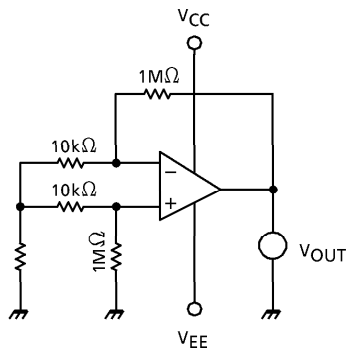

- $V_{IO} = V_{OUT} / 100$
- $SVRR = 20 \log E$ (dB)

$$E = \left| \frac{V_{OUT1} - V_{OUT2}}{(V_{CC1} - V_{EE1}) - (V_{CC2} - V_{EE2})} \right| \times \frac{1}{100}$$

- V_{OUT1} : V_{OUT} (V_{CC} , $V_{EE} = \pm 8V$)
- V_{OUT2} : V_{OUT} (V_{CC} , $V_{EE} = \pm 18V$)
- V_{CC1} : $V_{CC} = -8V$
- V_{EE1} : $V_{EE} = -8V$
- V_{CC2} : $V_{CC} = +18V$
- V_{EE2} : $V_{EE} = -18V$

(2) I_I , I_{IO}

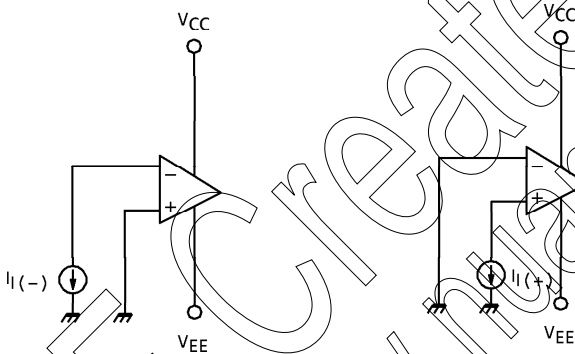

$$I_{IO} = |I_I(-) - I_I(+)|$$

(3) CMV_{IN} , $CMRR$

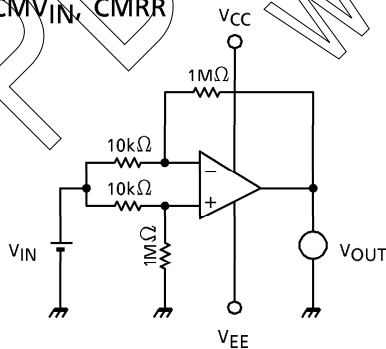

- $CMRR = 20 \log G_D / G_C$ (dB)
- G_D : DIFFERENTIAL VOLTAGE GAIN
- G_C : COMMON MODE VOLTAGE GAIN
- CMV_{IN} : $V_{IN} = -12V, 12V$ SUPPLIES

(4) I_{CC}

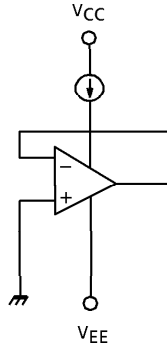

- $I_{CC} : V_{CC}, V_{EE} = \pm 15V$

(5) G_V, f_T

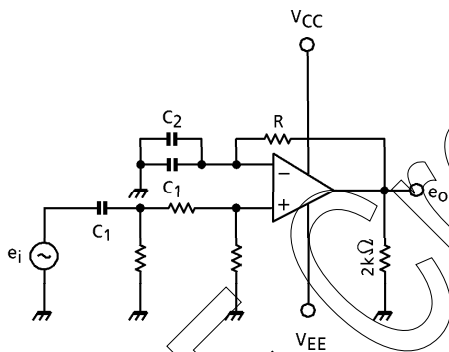

- $G_V = 20 \log e_o / e_i$ (dB)
- $R \geq 1 / \omega C_1$
- C_1 : COUPLING CONDENSER
- C_2 : HIGH FREQUENCY BYPASS CONDENSER
- f_T : INPUT FREQUENCY AT $e_i = e_o$

(6) V_{OM}, V_{OMR}

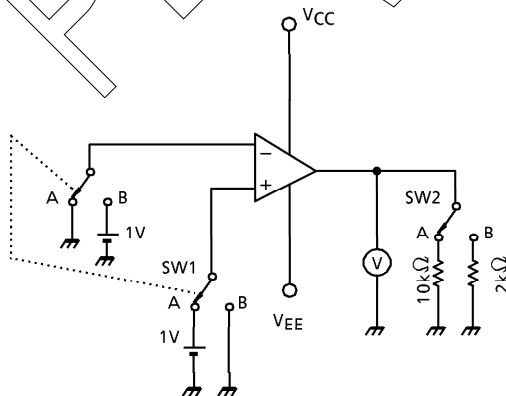

- $V_{OM} : (+) : SW1$ IS SIDE A, $SW2$ IS SIDE A
- $V_{OM} : (-) : SW1$ IS SIDE B, $SW2$ IS SIDE A
- $V_{OMR} : (+) : SW1$ IS SIDE A, $SW2$ IS SIDE B
- $V_{OMR} : (-) : SW1$ IS SIDE B, $SW2$ IS SIDE B

(7) I_{sink}

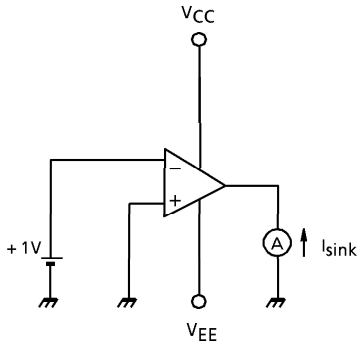

(8) I_{source}

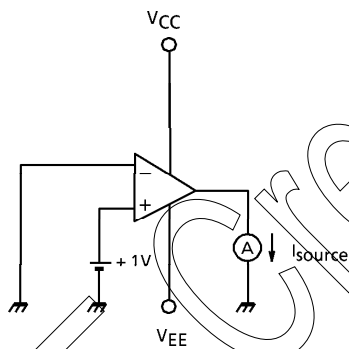

(9) SR

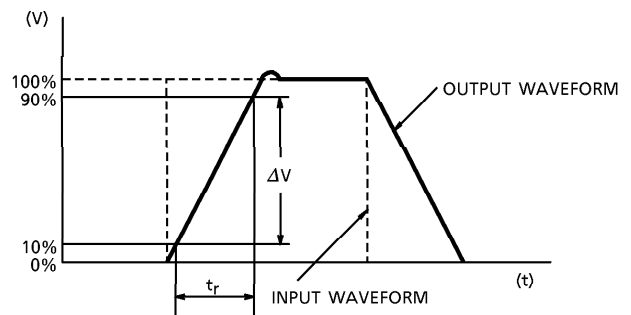
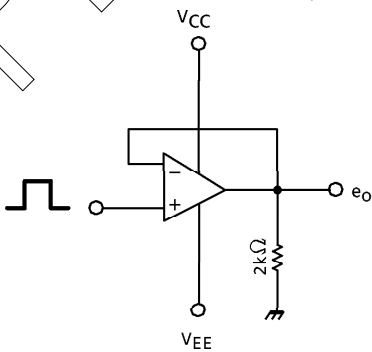

CHARACTERISTIC

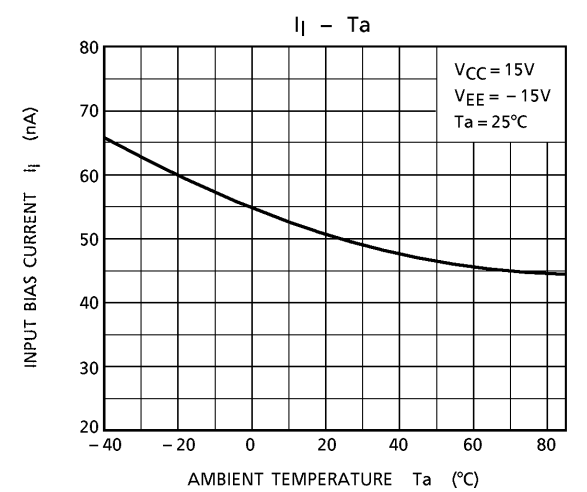
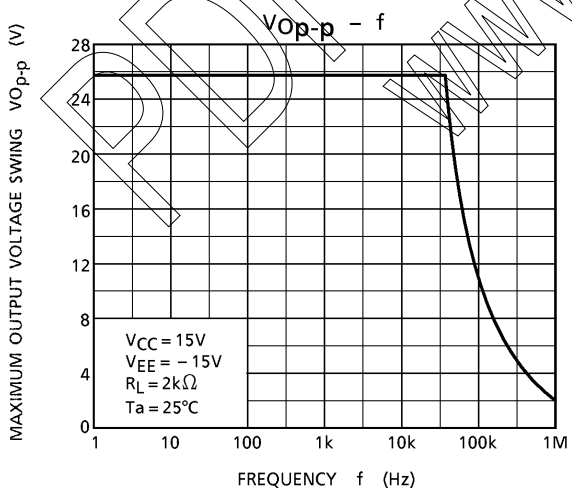
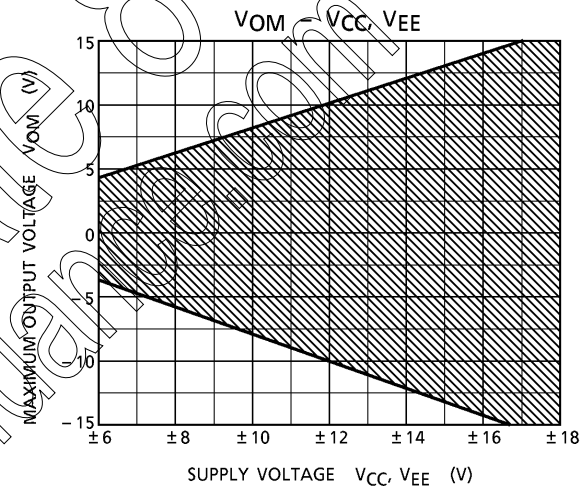
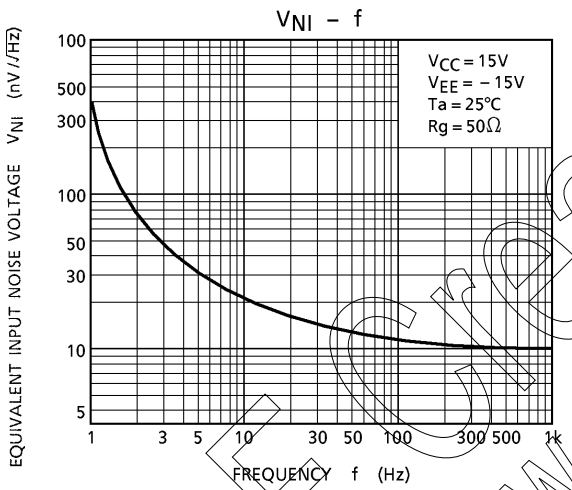
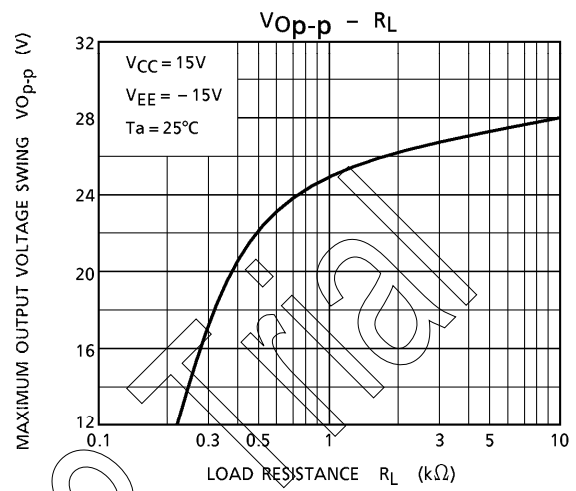
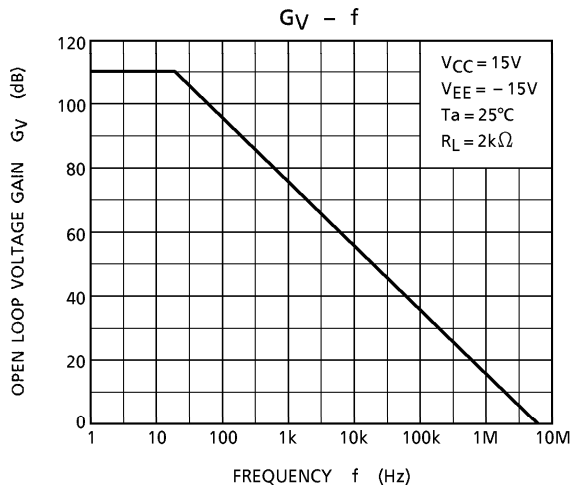

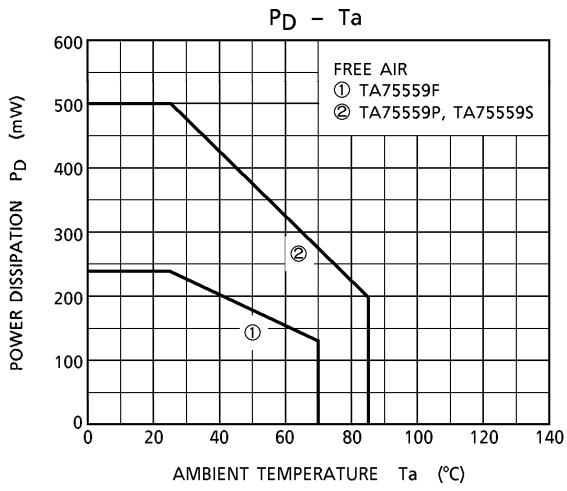

PDF Create 8 Trial
www.nuance.com

PACKAGE DIMENSIONS
DIP8-P-300-2.54A

Unit : mm

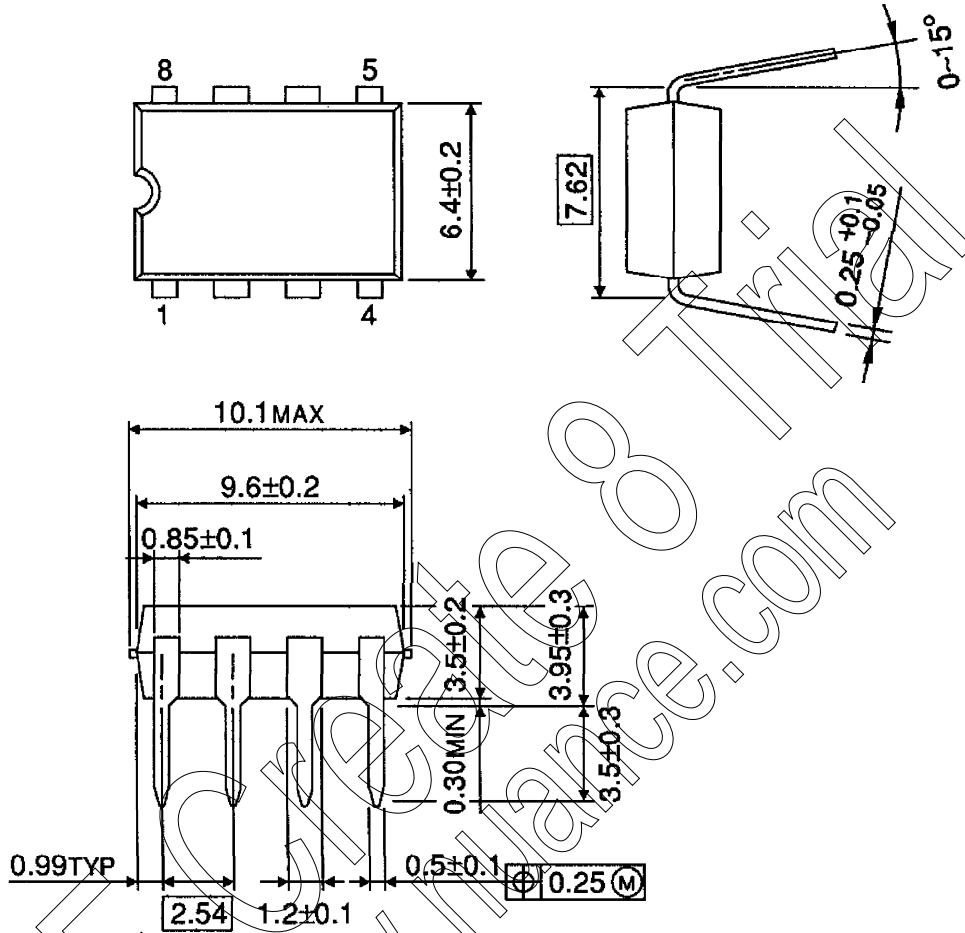

Weight : 0.5g (Typ.)

PACKAGE DIMENSIONS
SIP9-P-2.54A

Unit : mm

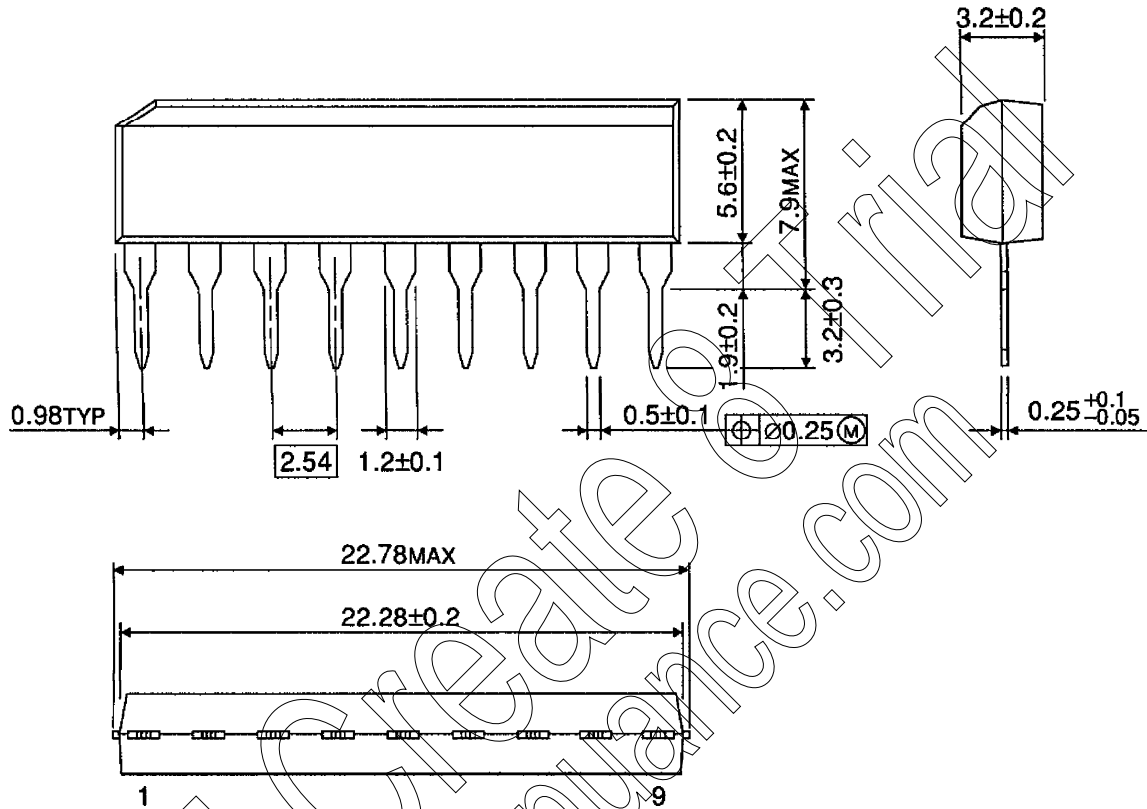

Weight : 0.9g (Typ.)

PDF created by www.nuance.com

PACKAGE DIMENSIONS
SOP8-P-225-1.27

Unit : mm

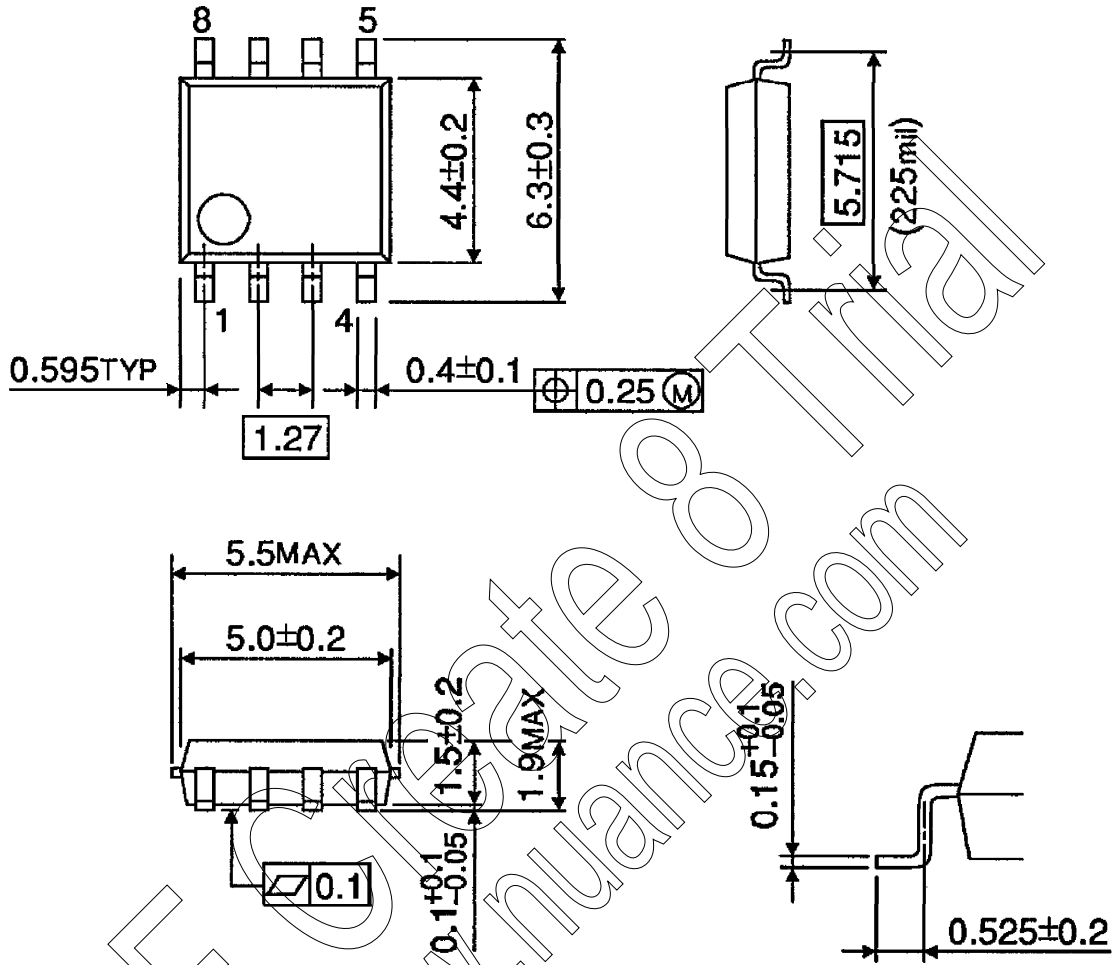

Weight : 0.1g (Typ.)

RESTRICTIONS ON PRODUCT USE

000707EBA

- TOSHIBA is continually working to improve the quality and reliability of its products. Nevertheless, semiconductor devices in general can malfunction or fail due to their inherent electrical sensitivity and vulnerability to physical stress. It is the responsibility of the buyer, when utilizing TOSHIBA products, to comply with the standards of safety in making a safe design for the entire system, and to avoid situations in which a malfunction or failure of such TOSHIBA products could cause loss of human life, bodily injury or damage to property. In developing your designs, please ensure that TOSHIBA products are used within specified operating ranges as set forth in the most recent TOSHIBA products specifications. Also, please keep in mind the precautions and conditions set forth in the "Handling Guide for Semiconductor Devices," or "TOSHIBA Semiconductor Reliability Handbook" etc..
- The TOSHIBA products listed in this document are intended for usage in general electronics applications (computer, personal equipment, office equipment, measuring equipment, industrial robotics, domestic appliances, etc.) These TOSHIBA products are neither intended nor warranted for usage in equipment that requires extraordinarily high quality and/or reliability or a malfunction or failure of which may cause loss of human life or bodily injury ("Unintended Usage"). Unintended Usage include atomic energy control instruments, airplane or spaceship instruments, transportation instruments, traffic signal instruments, combustion control instruments, medical instruments, all types of safety devices, etc.. Unintended Usage of TOSHIBA products listed in this document shall be made at the customer's own risk.
- The products described in this document are subject to the foreign exchange and foreign trade laws.
- The information contained herein is presented only as a guide for the applications of our products. No responsibility is assumed by TOSHIBA CORPORATION for any infringements of intellectual property or other rights of the third parties which may result from its use. No license is granted by implication or otherwise under any intellectual property or other rights of TOSHIBA CORPORATION or others.
- The information contained herein is subject to change without notice.