

UTC TA7611AP LINEAR INTEGRATED CIRCUIT

FM IF/AM TUNER SYSTEM

DESCRIPTION

The UTC TA7611AP is a monolithic integrated circuit, designed for the VIF stage in color and B/W TV receiver. The UTC TA7611AP is used for Forward AGC type.

FEATURES

- *High gain wide band IF amplifier
- *Gain reduction with excellent stability
- *Excellent DG/DP and S/N characteristics
- *Negative video output signal
- *Fast AGC action due to noise inverter and peak AGC
- *Switch off the video part VTR SW

FUNCTIONS

- *Three controlled IF amplifier stages
- *Video demodulator controlled by picture carrier
- *Black noise and white noise inverter
- *Peak AGC
- *DC amplifier for RF AGC output
- *Quadrature detector for AFT
- *DC amplifier for AFT

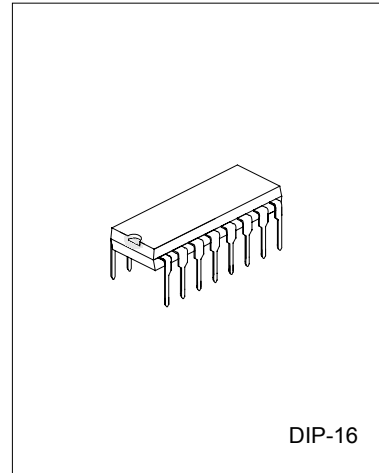

BLOCK DIAGRAM

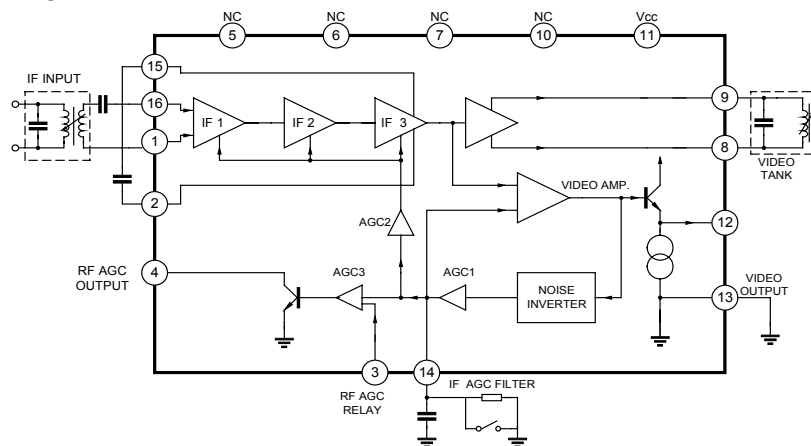

UTC TA7611AP LINEAR INTEGRATED CIRCUIT

ABSOLUTE MAXIMUM RATINGS(Ta=25°C)

PARAMETER	SYMBOL	VALUE	UNIT
Supply Voltage	VCC	15	V
Open Loop Voltage	V4	15	V
Video DC Output Current	I12	6	MA
Power Dissipation	PD	1.4	W
Operating Temperature	TOPR	-20 ~ +65	°C
Storage Temperature	TSTG	-55 ~ +150	°C

ELECTRICAL CHARACTERISTICS(Ta=25°C, Vcc=12V, fo=45.75MHz, unless otherwise specified)

PARAMETER	SYMBOL	TEST CONDITIONS	MIN.	TYP.	MAX.	UNIT
Recommended Supply Voltage	VCC		10.8	12	13.2	V
Quiescent Circuit Current	ICCQ		42	51	63	mA
Video DC Output	V12		5.2	5.5	5.8	V
AFT DC Output Voltage	V5-V6	SW1: on, SW2: on	5.3	6.8	8.3	V
AFT Output Offset Voltage	V5-V6	SW1: on, SW2: on	-1.5	0	1.5	V
RF AGC Residual Output Voltage	V4(SAT)	SW4:1			0.5	V
RF AGC Leak Current	I4(LEAK)	VCC=12V, SW3:1, SW4:1			1	μA
Video Sensitivity	S _{VI}	V12=0.8VP-P f0=45.75MHZ, AM=30%	100	200	300	μVrms
AGC Range	VAGC (IF)	VCC=12V, f0=45.75MHZ V14=11.5V→4.0V	60	64		dB
Sync Tip Level Voltage (pin12)	VSYNC		2.3	2.5	2.7	V
Maximum IF Input Voltage	V _{I(MAX)}		100	120		mVrms
White Noise Threshold (pin12)	V _{WTH}		5.8	6.2	6.6	V
White Noise Clamp Level (pin12)	V _{WCL}		3.7	4.1	4.5	V
Black Noise Threshold (pin12)	V _{BTH}		1.4	1.6	1.8	V
Black Noise Clamp Level (pin12)	V _{BCL}		2.9	3.3	3.7	V
Video Frequency Response	GV(IF)	Input 45.75MHz, Sweep Generator	4.5	5.5		MHz
Suppression of Carrier	CL	SG1=100mVrms SG2, SG3->OFF	40	50		dB
Suppression of 2 nd Carrier	I2ND	SG1=100mVrms SG2, SG3->OFF	40	50		dB
920KHz Beat Level	I920	SG1=100mVrms SG2=SG3=32mVrms	33	38		dB
Differential Gain	DG			7	10	dB
Differential Phase	DP			3.5	5	Degree
Input Impedance	RIN CIN	fo=45.75MHz, Between pin16~1	3.0	4.5 2	6 5	K pF
AFT Output Upper Voltage	V5, V6(UP)		11.7	11.9	12	V
AFT Output Lower Voltage	V5, V6(LOW)		1.8	2.3	2.8	V
Maximum Available Current	I4(MAX)		7			mA
AFT Sensitivity	S _{AFT}			16		KHz/V

UTC TA7611AP LINEAR INTEGRATED CIRCUIT

TEST CIRCUIT 1

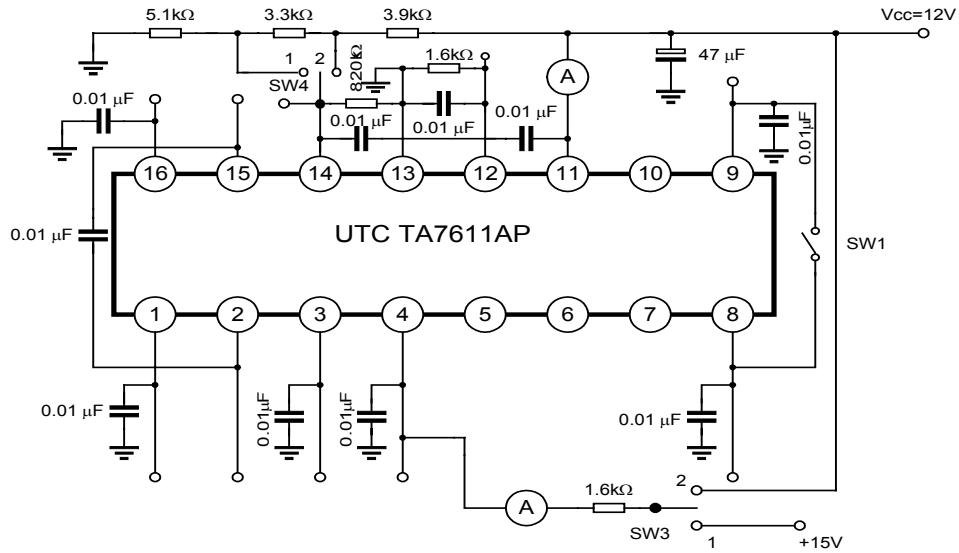

TEST CIRCUIT 2

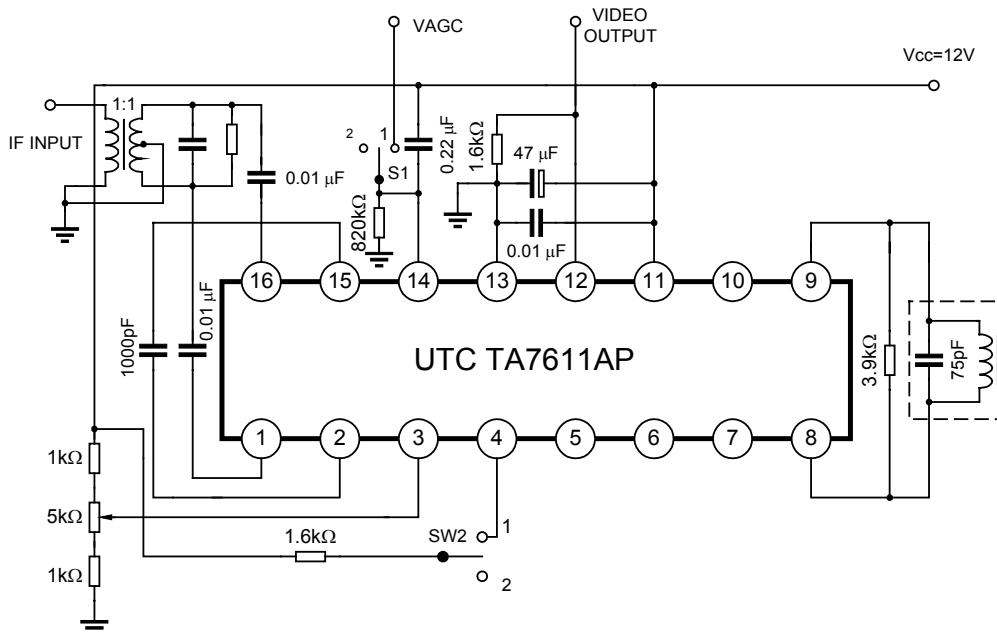

UTC TA7611AP LINEAR INTEGRATED CIRCUIT

TEST CIRCUIT 3

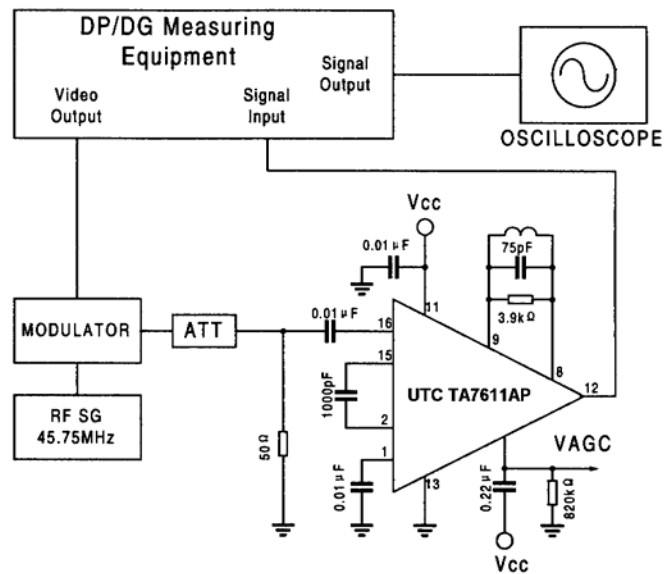

TEST CIRCUIT 4

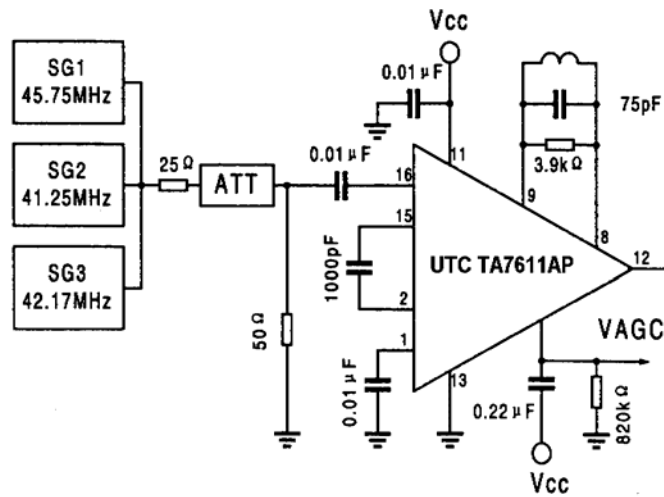

UTC TA7611AP LINEAR INTEGRATED CIRCUIT

TYPICAL APPLICATION CIRCUIT

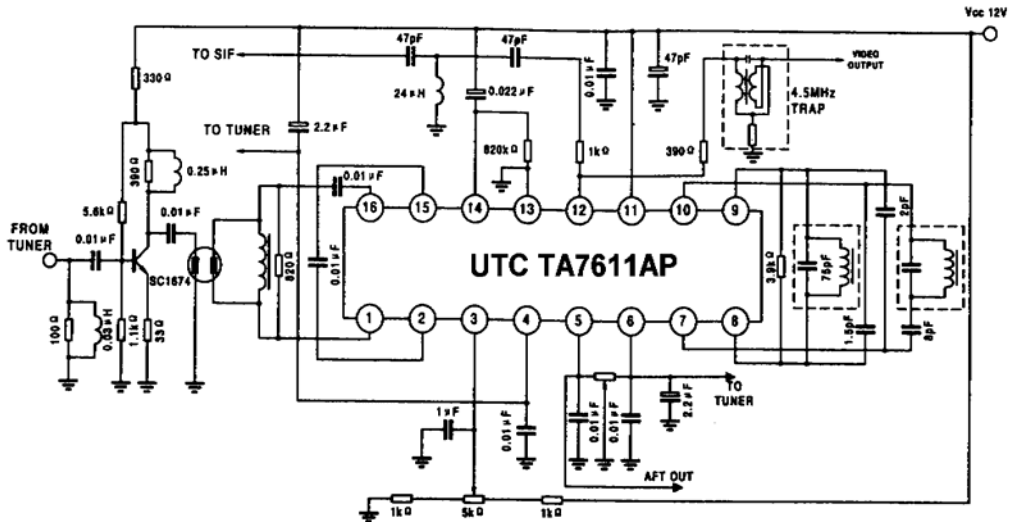

UTC assumes no responsibility for equipment failures that result from using products at values that exceed, even momentarily, rated values (such as maximum ratings, operating condition ranges, or other parameters) listed in products specifications of any and all UTC products described or contained herein. UTC products are not designed for use in life support appliances, devices or systems where malfunction of these products can be reasonably expected to result in personal injury. Reproduction in whole or in part is prohibited without the prior written consent of the copyright owner. The information presented in this document does not form part of any quotation or contract, is believed to be accurate and reliable and may be changed without notice.