

**AM/FM 1 CHIP TUNER SYSTEM IC (1.5V USE)  
TA7792**

**GENERAL DESCRIPTION**

The TA7792 is AM/FM 1 chip tuner system (FM FRONT END+AM/FM IF) ICs, which is designed for low voltage operation (1.5V,3.0V). Those are especially suitable for stereo headphone radio and radio cassette recorder equipments. These item can realize the low power dissipation and few external parts.

**FEATURES**

- AM detector coil-less
- FM mixer coil-less
- Switchover between AM/FM mode is possible with one-make switch.
- Operating supply voltage range:  $V_{cc}(opr)=0.95\sim 5V(T_a=25^{\circ}C)$
- Excellent low supply current ( $V_{cc}=1.5V, T_a=25^{\circ}C$ )

$I_{cc}(AM)=1.2mA(Typ.)$

$I_{cc}(FM)=4.0mA(Typ.)$

**BLOCK DIAGRAM**

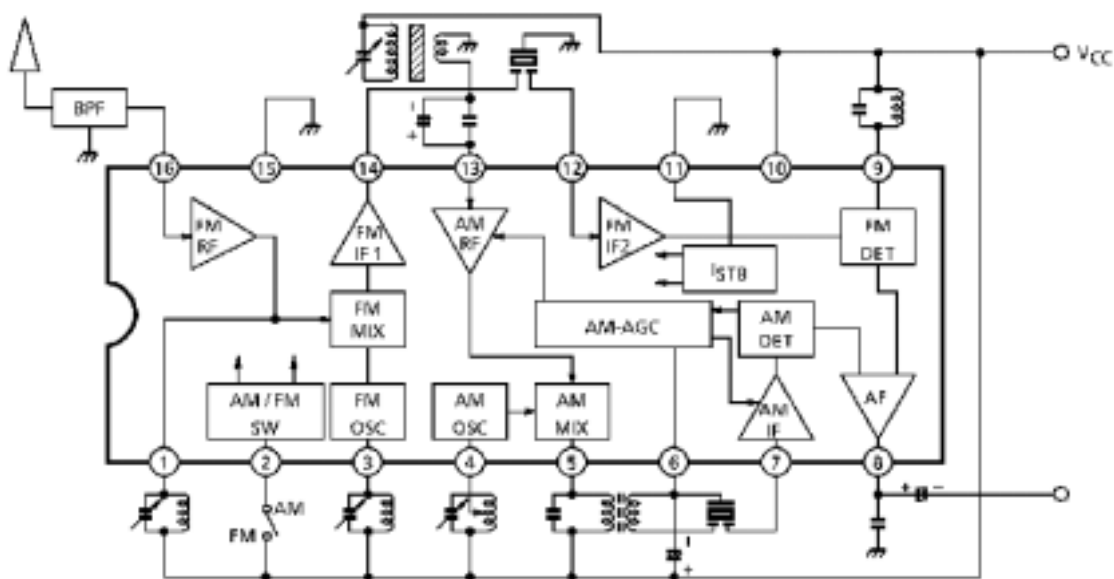

## PIN CONNECTION

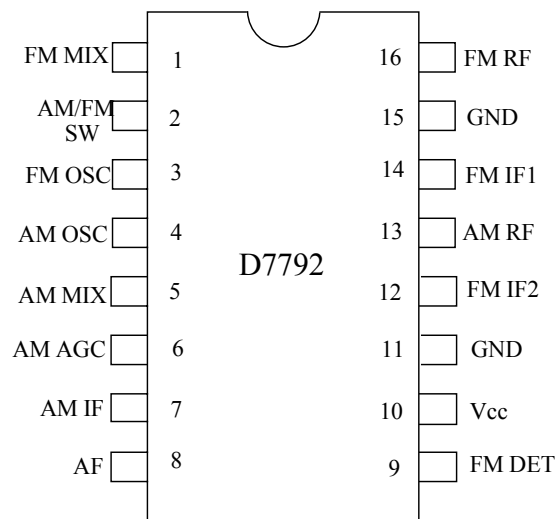

## TERMINAL VOLTAGE:

Terminal voltage at no signal with test circuit ( $V_{cc}=1.5V$ ,  $T_a=25^{\circ}C$ )

Pin No.	Pin Name	Sym- bol	Typ.		Unit	Pin No.	Pin Name	Sym- bol	Typ.		Unit
			AM	FM					AM	FM	
1	FM RF OUT	V1	-	1.5	V	9	FM DET	V9	1.5	1.5	V
2	Vcc1	V2	-	1.5	V	10	Vcc2	V10	1.5	1.5	V
3	FM OSC	V3	-	1.5	V	11	GND2	V11	0	0	V
4	AM OSC	V4	1.5	1.5	V	12	FM IF IN	V12	-	0.7	V
5	AM MIX OUT	V5	1.5	1.5	V	13	AM RF IN	V13	0.7	-	V
6	AM AGC	V6	0.8	-	V	14	FM MIX OUT	V14	-	0.8	V
7	AM IF IN	V7	1.4	1.5	V	15	GND1	V15	0	0	V
8	AF OUT	V8	0.6	0.6	V	16	FM RF IN	V16	-	0.7	V

## MAXIMUM RATINGS ( $T_a=25^{\circ}C$ )

Characteristics	Symbol	Rating	Unit
Supply Voltage	Vcc	5	V
Power Dissipation	P <sub>D</sub>	750(DIP)	mW
		350(SOP)	
Operating Temperature	Topr	-25~75	°C
Storage Temperature	Tstg	-55~150	°C

**ELECTRICAL CHARACTERISTICS** ( $V_{cc}=1.5V$ ,  $T_a=25^{\circ}C$ )

Characteristics	Sym- bol	Test Cir- Cuit	Test Condition	Min.	Typ.	Max.	Unit
Supply Current	I <sub>cc</sub>	1	FM: V <sub>in</sub> =0	-	4.0	5.2	mA
		1	AM: V <sub>in</sub> =0	-	1.2	1.8	
Output Resistance Pin 8	R <sub>o</sub>	1	FM: f=1kHz	-	1.4	-	kΩ
		1	AM: f=1kHz	-	8.0	-	
AM: V <sub>in</sub> =60dBμV EMF, f=1MHz, f <sub>m</sub> =1KHz, MOD=30%							
Voltage Gain	G <sub>v</sub>	1	V <sub>in</sub> =30dBμV EMF	14	25	50	mVrms
Recovered Output Voltage	V <sub>OD</sub>	1	-	25	40	60	mVrms
Total Harmonic Distortion	THD	1	-	-	1.5	-	%
Signal To Noise Ratio	S/N	1	-	-	40	-	dB
Oscillator Stop Supply Voltage	V <sub>stop</sub>	1	V <sub>in</sub> <-20dBμV EMF	-	0.85	0.95	V
FM: V <sub>in</sub> =60dBμV EMF, f=83MHz, f <sub>m</sub> =1kHz, f = ± 22.5kHz							
Input Limiting Voltage	V <sub>in(lim)</sub>	1	-3dB limiting	-	10	16	dBμV EMF
Total Harmonic Distortion	THD	1	-	-	0.25	-	%
Signal To Noise Ratio	S/N	1	-	-	62	-	dB
Quiescent Sensitivity	Q <sub>s</sub>	1	S/N=30dB	-	12	-	dBμV EMF
AM Rejection Ratio	AMR		MOD=30%	-	30	-	dB
Oscillator Voltage	V <sub>osc</sub>	2	F=60MHz	53	90	135	mVrms
Oscillator Stop Supply Voltage	V <sub>stop</sub>	1	V <sub>in</sub> <-20dBμV EMF	-	0.85	0.95	V
Recovered Output Voltage	V <sub>OD</sub>	1	-	28	45	68	mVrms

TEST CIRCUIT

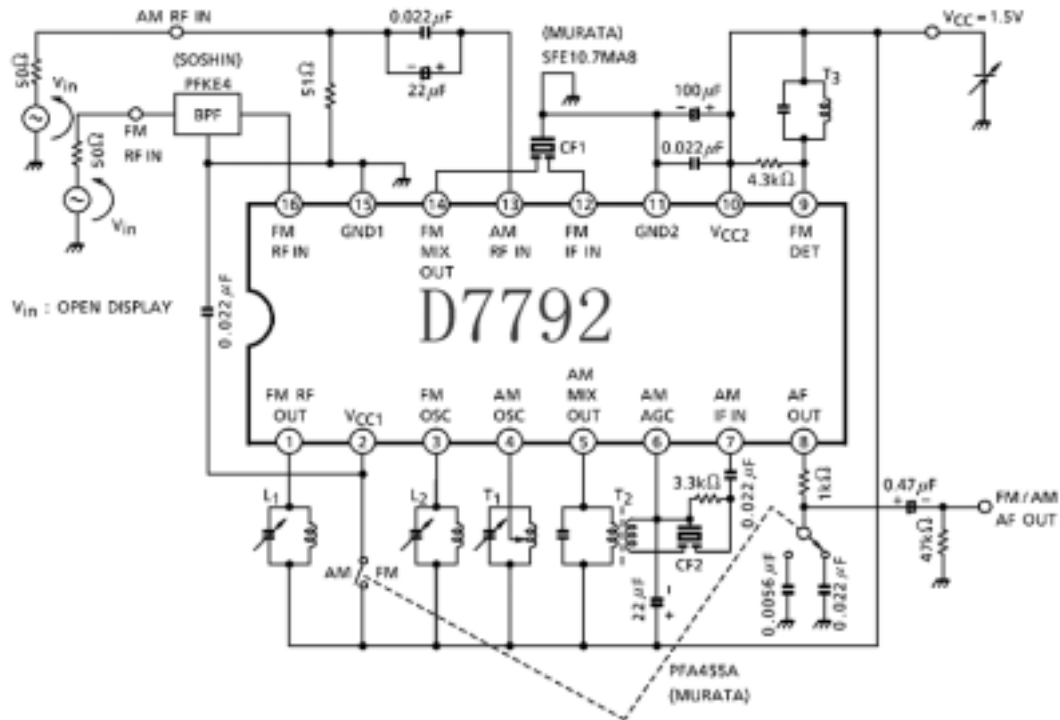

TEST CIRCUIT 1

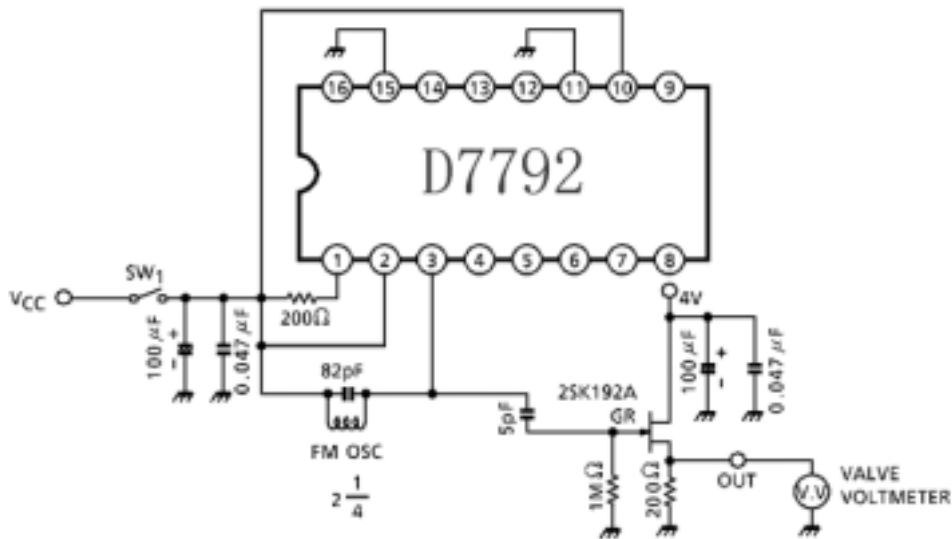

TEST CIRCUIT 2

COIL DATA ( TEST CIRCUIT )

COIL STAGE	TEST FREQUENCY	L ( $\mu$ H )	C <sub>o</sub> (pF)	Q <sub>o</sub>	TURN				WIRE (mm $\Phi$ )
					1-2	2-3	1-3	4-6	
L1 FM RF	100MHz	0.053	-	100	-	-	1.75	-	0.5UEW
L2 FM OSC	100MHz	0.065	-	100	-	-	2.25	-	0.5UEW
T1 AM OSC	796kHz	288	-	115	13	73	-	-	0.08UEW
T2 AM IFT	455kHz	-	180	120	-	-	180	15	0.06UEW
T3 FM DET	10.7MHz	-	82	110	-	-	13	-	0.12UEW

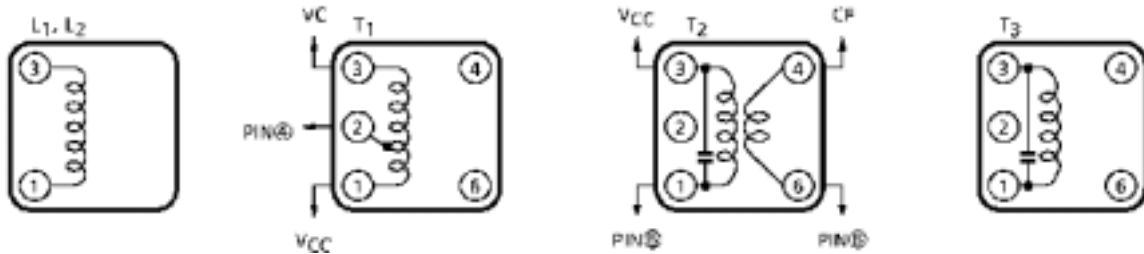

APPLICATION NOTE

<FM SECTION>

- RF amplifier (see Fig.1)

This stage is composed of the emitter-grounded and cascade connection amplifier.

The input impedance of pin 16 is about 260 $\Omega$ , which is determined by D1.

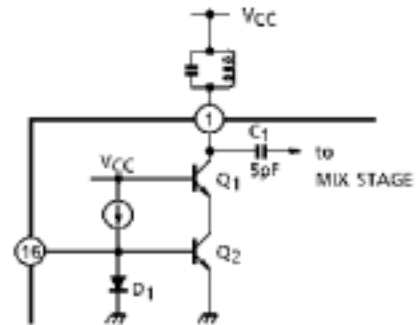

Fig.1

- Mixer amplifier (see Fig.2)

The amplified RF signal is transformed into IF signal by the mixer circuit which is composed of a differential amplifier.

The amplified IF signal is appeared through the emitter follower circuit at pin 14. The output impedance of the ceramic filter.

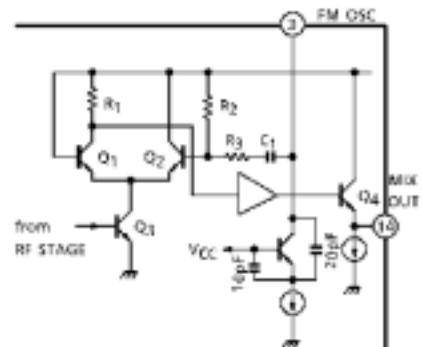

Fig.2

(note)

the spurious characteristic is determined by the characteristic of the ceramic filter (10.7MHz), because the mixer coil is dispensable. It is possible to improve the spurious characteristic that the two ceramic filters of different characteristics are connected in series.

- IF limiter amplifier (see Fig.3)

The IF limiter amplifier is composed of six emitter-grounded amplifiers and a differential amplifier. The basis composition of the emitter-ground amplifiers is shown as Fig.3

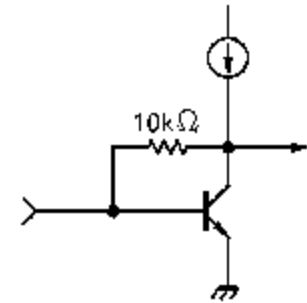

Fig.3

- Detector circuit

This stage is composed of the quadrature detector circuit, which has double balanced.

<AM SECTION>

- RF amplifier (see Fig.4)

This stage is composed of emitter-grounded amplifier, the input impedance of which has about 7.3kΩ. It is necessary to connect as Fig.4, because the condenser, C1 is available to the audio by-pass of the RF-AGC, the noise of low frequency.

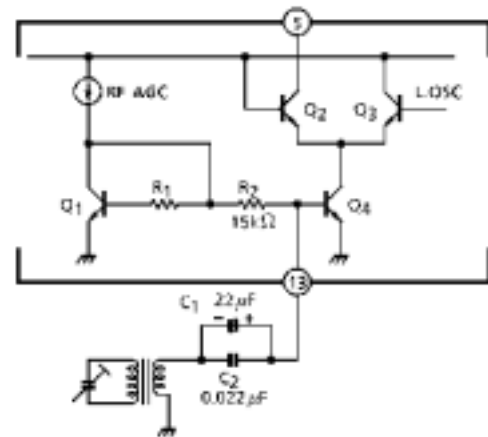

Fig.4

- Mixer circuit

The amplified RF signal is transformed into IF signal by the mixer circuit, which is composed of a differential amplifier.

- IF amplifier

This stage is composed of four emitter-grounded amplifiers and the two differential amplifiers. The input impedance is rather high, because it is changed by the amplitude of input signal (AGC level). So the input terminal of the IF amplifier must be matched with the impedance of ceramic filter.

<COMMON SECTION>

- AM/FM mode switchover

Switchover between AM/FM mode is possible with one-make switch. In case of the opened, this IC has AM mode.

Another in case that the terminal is connected to Vcc directly, that has FM mode.

And the terminal of pin 2 is Vcc terminal of FM FRONT END section, too.

- Output circuit (see Fig.5)

Both of the AM/FM detector signal is appeared through the pin 8.

Those output are chosen by the mode switchover.

At the same time, the output impedance is changed as follow at AM/FM mode, due to cut the AM carrier signal and pass the FM composite signal smoothly, with only one condenser.

$R_{out(AM)}=8k\Omega$  (Typ.)

$R_{out(FM)}=1.4k\Omega$  (Typ.)

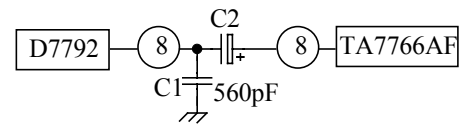

CHARACTERISTICS CURVES

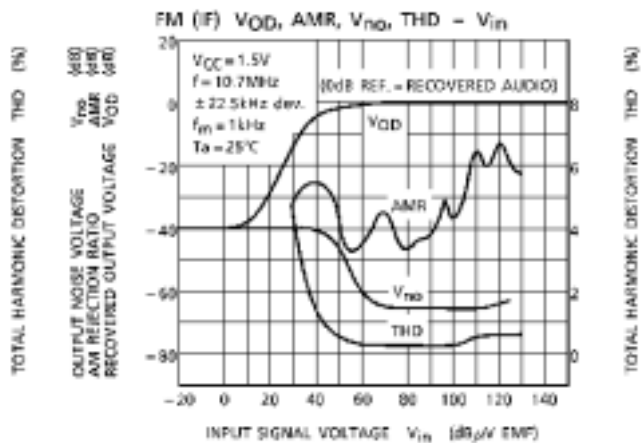
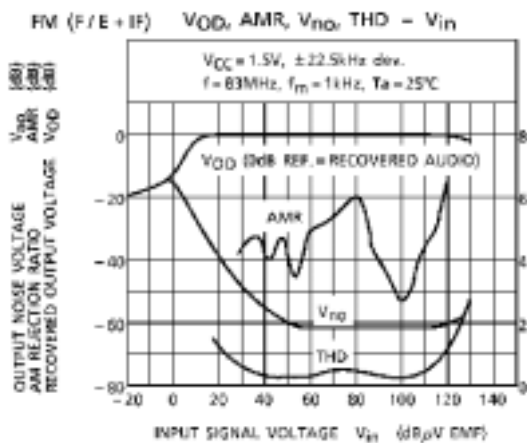

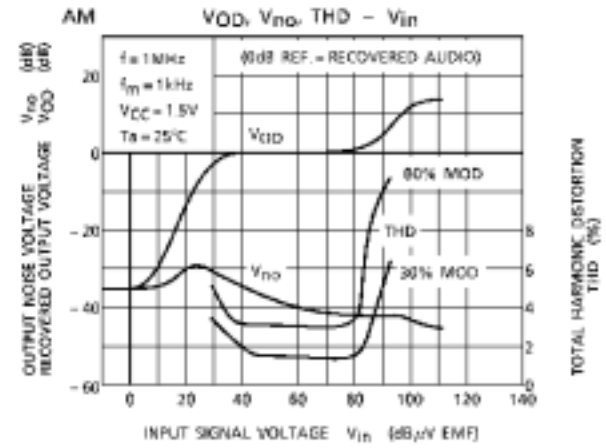
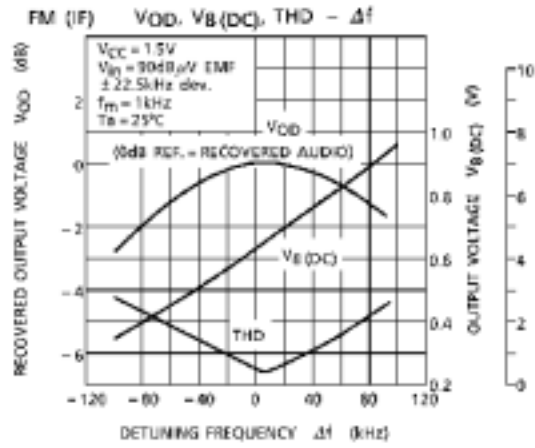
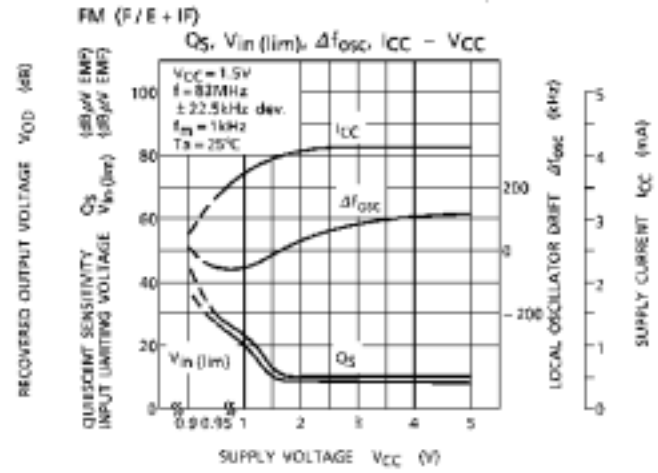
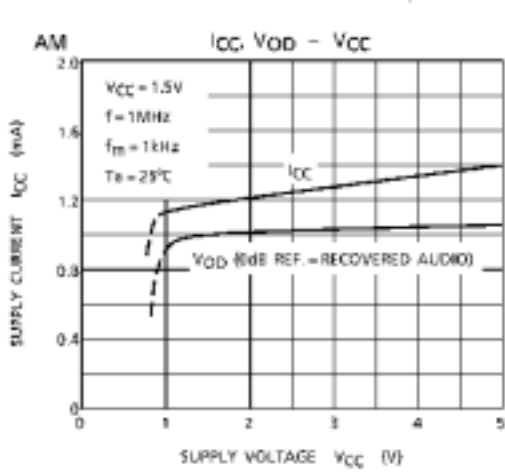



Outline Drawing

DIP16 :

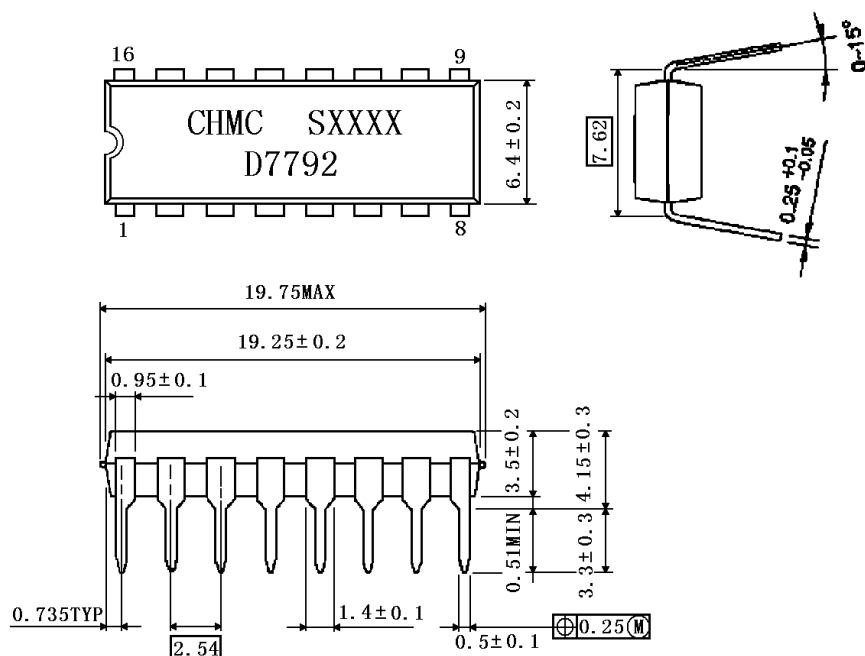

SOP16

