

TA8001S

5V VOLTAGE REGULATOR WITH RESET TIMER

The TA8001S is an IC specially designed for automotive microcomputer systems. It produces an output voltage of 5 ± 0.5 V without need for adjustment from its accurate reference voltage and amplifier circuit.

At power-on, it outputs a reset signal to reset the system. It will also output a reset signal when the 5V output voltage drops below 92% because of external disturbance or other problem. Since it is also designed to have a small bias current, power consumption on the system can be reduced.

FEATURES

- Accurate output : 5 ± 0.5 V
- Standby output : 3.5V
- Low bias current : 150 μ A (Typ.)
- Power-on reset timer
- Operating temperature range : from -40 to 85° C
- Wide operating voltage range : 30V (max.)
- Small SIP-7 pin

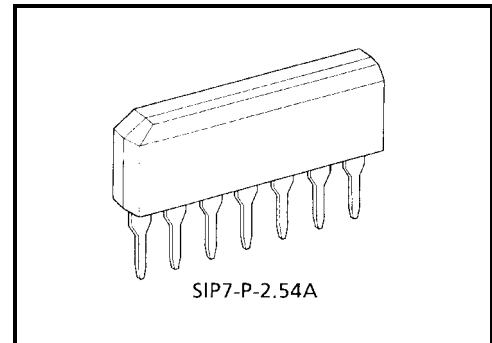

SIP7-P-2.54A

Weight: 0.7 g (typ.)

BLOCK DIAGRAM AND PIN LAYOUT

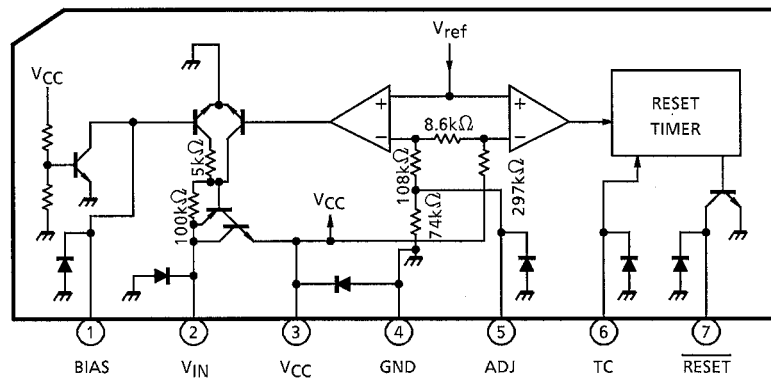

PIN DESCRIPTION

PIN No.	SYMBOL	DESCRIPTION									
1	BIAS	Power supply starting pin. The starting current is supplied through a resistor to which the input voltage is applied. The output current from this starting current is as follows : $I_{OUT}(V_{CC} \text{ Pin}) \geq 3000 \times (V_{IN} - 0.6) / (200 + R_1) \text{ (mA)}$ where R_1 is the external resistance attached to Bias Pin (k Ω) . When the output voltage rises above 2.7V, its control is transferred from the starting circuit to the internal control circuit.									
2	V_{IN}	Power supply input pin.									
3	V_{CC}	Power supply pin for internal circuit. The output voltage can also be detected at this pin.									
4	GND	Grounded									
5	ADJ	The output voltage can be adjusted by inserting a resistor between ADJ and GND or between ADJ and V_{CC} . <table border="1" style="margin: 10px auto;"> <thead> <tr> <th>Mode</th> <th>ADJ Pin</th> <th>Output Voltage V_{REG}</th> </tr> </thead> <tbody> <tr> <td>Standby</td> <td>OPEN</td> <td>3.5V</td> </tr> <tr> <td>Normal</td> <td>GND</td> <td>5.0V</td> </tr> </tbody> </table>	Mode	ADJ Pin	Output Voltage V_{REG}	Standby	OPEN	3.5V	Normal	GND	5.0V
Mode	ADJ Pin	Output Voltage V_{REG}									
Standby	OPEN	3.5V									
Normal	GND	5.0V									
6	TC	Time setting pin for reset timer. Use external R_T and C_T to set the time.									
7	$\overline{\text{RESET}}$	NPN transistor open-collector output. This pin supplies a reset signal when the output drops below 92% of the specified level. After the output voltage increases above 92% of the specified level, the reset signal will be output for a period of time set at the TC pin.									

FUNCTIONAL DESCRIPTION

The TA8001S incorporates a constant-voltage 5V power supply function to feed the 5V logic circuits and a reset function to ensure stable operation of the system. These functions are explained below.

(1) Constant-voltage 5V power supply function

This constant-voltage function has the reference voltage V_{ref} in the IC that is insusceptible to temperature changes and input voltage fluctuations. The power supply circuit is designed in such a way that this voltage is stepped up to 5V by using an OP amp and a voltage-dividing resistor. These OP amp and dividing resistor and an output transistor connected to the OP amp output together configure a closed loop.

The output voltage of 5V is obtained by shorting the ADJ pin to GND. The output voltage is reduced to 3.5V by leaving this pin open, allowing for a further reduction in the amount of current consumed by the entire system during standby.

(2) System reset function (See Timing Chart)

- Voltage monitoring function

When powered on, the power-on reset timer starts counting the moment the voltage V_{CC} applied to the CPU exceeds 4.6V. When powered off, this voltage monitoring function outputs a reset signal immediately when V_{CC} drops below 4.6V. A reset signal also is output immediately when V_{CC} drops for some reason during normal operation. Then, when V_{CC} is restored to the normal voltage and exceeds 4.6V, the power-on reset timer starts counting.

- Power-on reset timer function

To allow the 5V constant voltage to stabilize at power-on, as well as prevent the circuit system from operating erratically at power-on, the device remains reset for a predetermined time before being released from the reset state. The duration of this time can be set as desired by choosing appropriate values for the external resistor and capacitor connected to the TC pin.

The system starts charging the capacitor when the V_{CC} voltage exceeds 4.6V. When this charging voltage exceeds 1.7V, the reset signal is inverted to deactivate the reset.

TIMING CHART

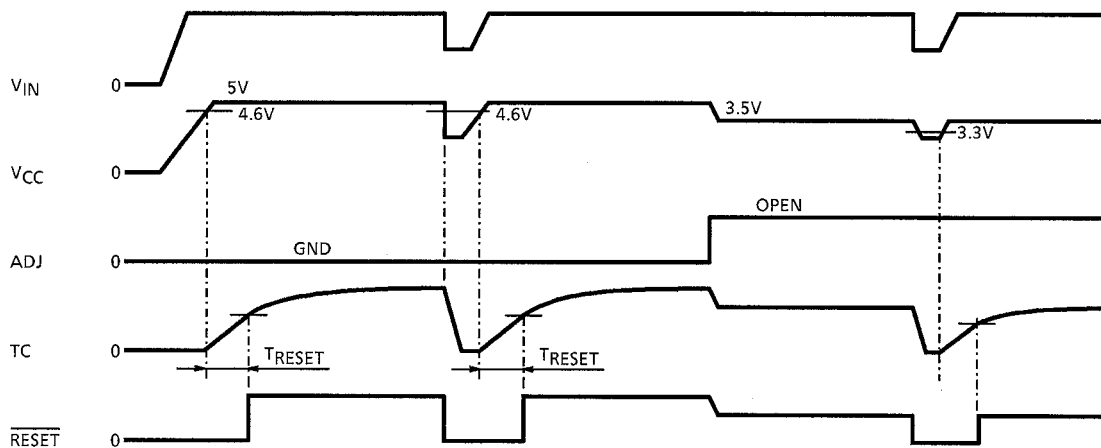

Note: T_{RESET} : Reset timer time

MAXIMUM RATINGS (Ta = 25°C)

CHARACTERISTIC	SYMBOL	RATING	UNIT
Input Voltage	V _{IN}	30	V
Output Current	I _{OUT1}	20	mA
	I _{OUT2}	1	mA
Output Voltage	V _{OUT2}	16	V
Power Dissipation	P _D	500	mW
Operating Temperature	T _{opr}	-40~85	°C
Storage Temperature	T _{stg}	-55~150	°C
Lead Temperature time	T _{sol}	260 (10s)	°C

Note: V_{IN} : BIAS input
 I_{OUT1}, V_{OUT1} : OUT output
 I_{OUT2}, V_{OUT2} : RESET output

ELECTRICAL CHARACTERISTICS (V_{IN} = 7 to 17V, Ta = -40 to 85°C, I_{LOAD} = 5mA)

CHARACTERISTIC	SYMBOL	PIN	TEST CIRCUIT	TEST CONDITION	MIN	TYP.	MAX	UNIT
Output Voltage	V _{REG}	V _{CC}	1		4.5	5.0	5.5	V
Line Regulation		V _{CC}	—	V _{IN} = 7~30V	—	0.2	1.0	%
Load Regulation		V _{CC}	—	I _{LOAD} = 2~10mA	—	0.5	2.0	%
Temperature Coefficient		V _{CC}	—		—	0.01	—	% / °C
Output Voltage	V _{OL}	$\overline{\text{RESET}}$	2	I _{OL} = 300μA	—	—	0.4	V
Output Leakage Current	I _{LEAK}	$\overline{\text{RESET}}$	3	V _{OUT} = 10V	—	—	5	μA
Input Current	I _{IN}	TC	4	V _{IN} = 0~V _{REG}	-2	—	2	μA
Threshold Voltage	V _{TH}	TC	5	TC : Low to High	—	1.7	—	V
Reset Detect Voltage		V _{CC}	—	V _{REG} = 5V	—	4.6	—	V
Standby Voltage	V _S	V _{CC}	6		3.1	3.5	3.9	V
Standby Current	I _S	V _{CC}	7	V _{IN} = 14V	—	150	300	μA
Reset Timer	T _{RESET}	$\overline{\text{RESET}}$	5		—	0.4× C _T R _T	—	ms

Note : The unit for C_T is μF, the unit for R_T is kΩ.

TEST CIRCUIT

1. V_{REG}

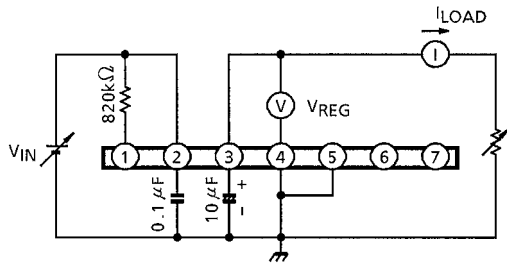

5. V_{RESET} , V_{TH} , T_{RESET}

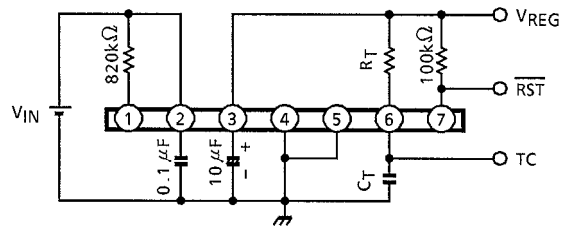

2. $V_{OL}(\overline{RESET})$

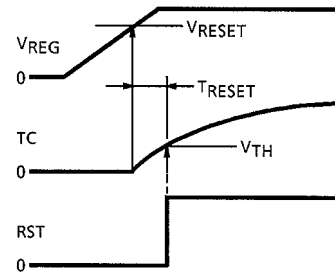
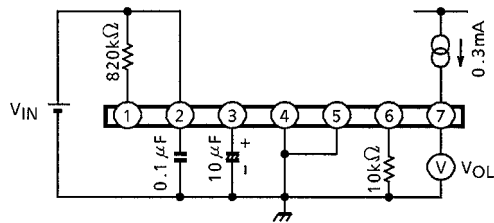

3. $I_{LEAK}(\overline{RESET})$

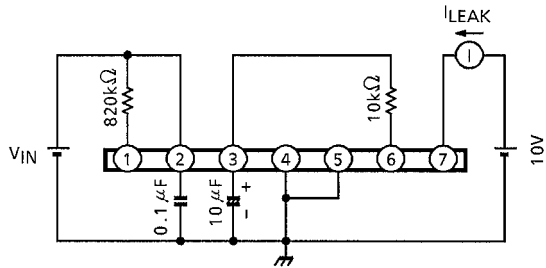

6. V_S

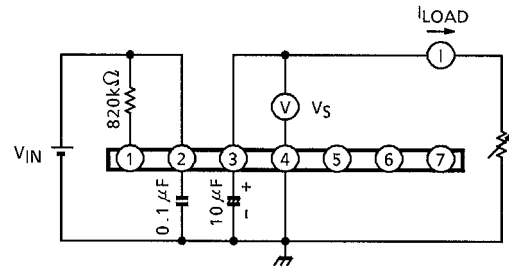

4. $I_{IN}(TC)$

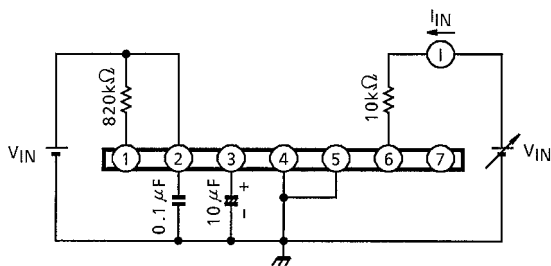

7. I_S

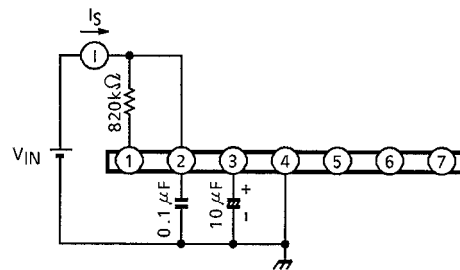

TYPICAL CHARACTERISTICS

1. Input-output Characteristic (RL = 500Ω)

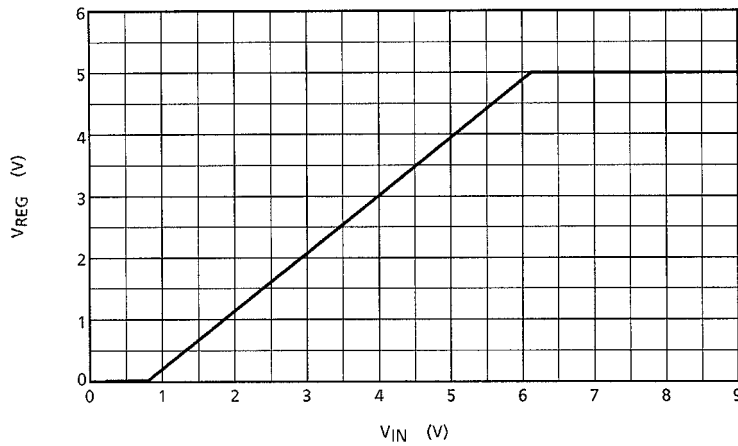

2. Reset Characteristic

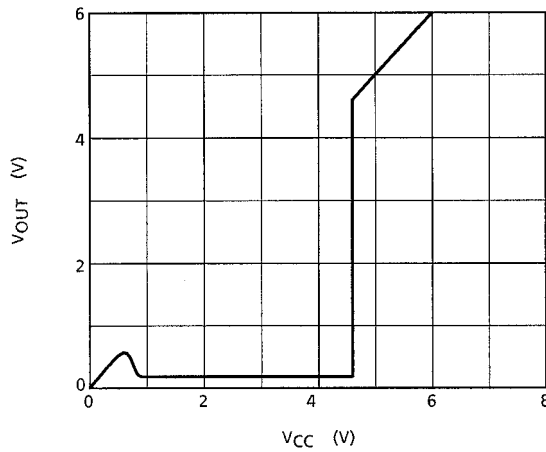

EQUIVALENT CIRCUIT

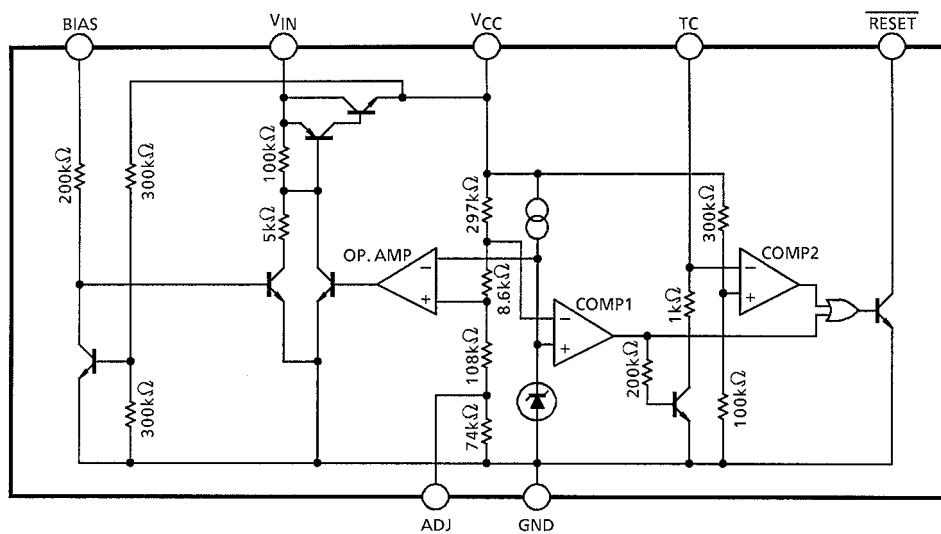

EXAMPLE OF APPLICATION CIRCUIT

$I_{LOAD} = 10\text{mA Max.}$ $V_{BATT} = 7\sim 17\text{V}$ (LOAD DUMP 120V_{peak} , 200ms)

1. 5V Standard Circuit

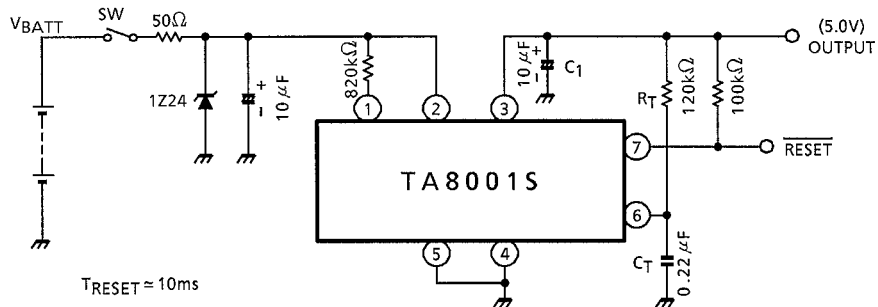

2. Backup Circuit

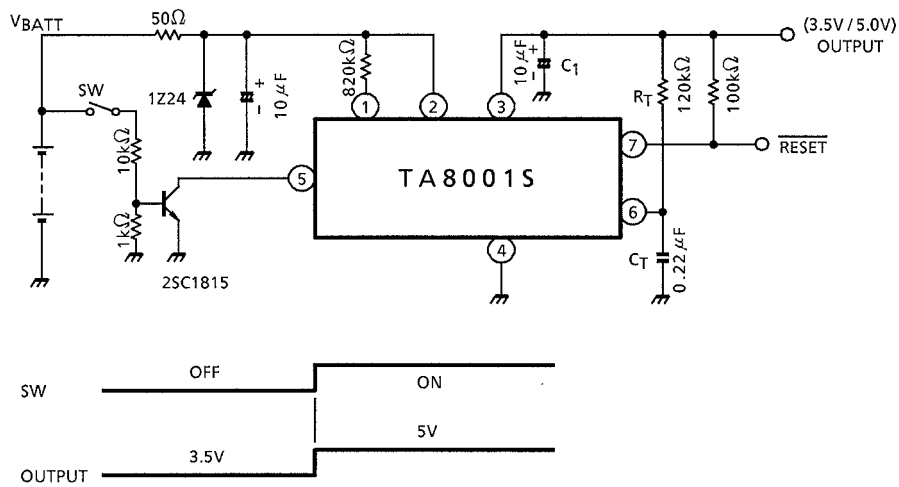

*: Use an output capacitor C_1 which has a low temperature dependence (such as a tantalum capacitor). Connect it as close to the IC as possible.

PACKAGE DIMENSIONS

SIP7-P-2.54A

Unit : mm

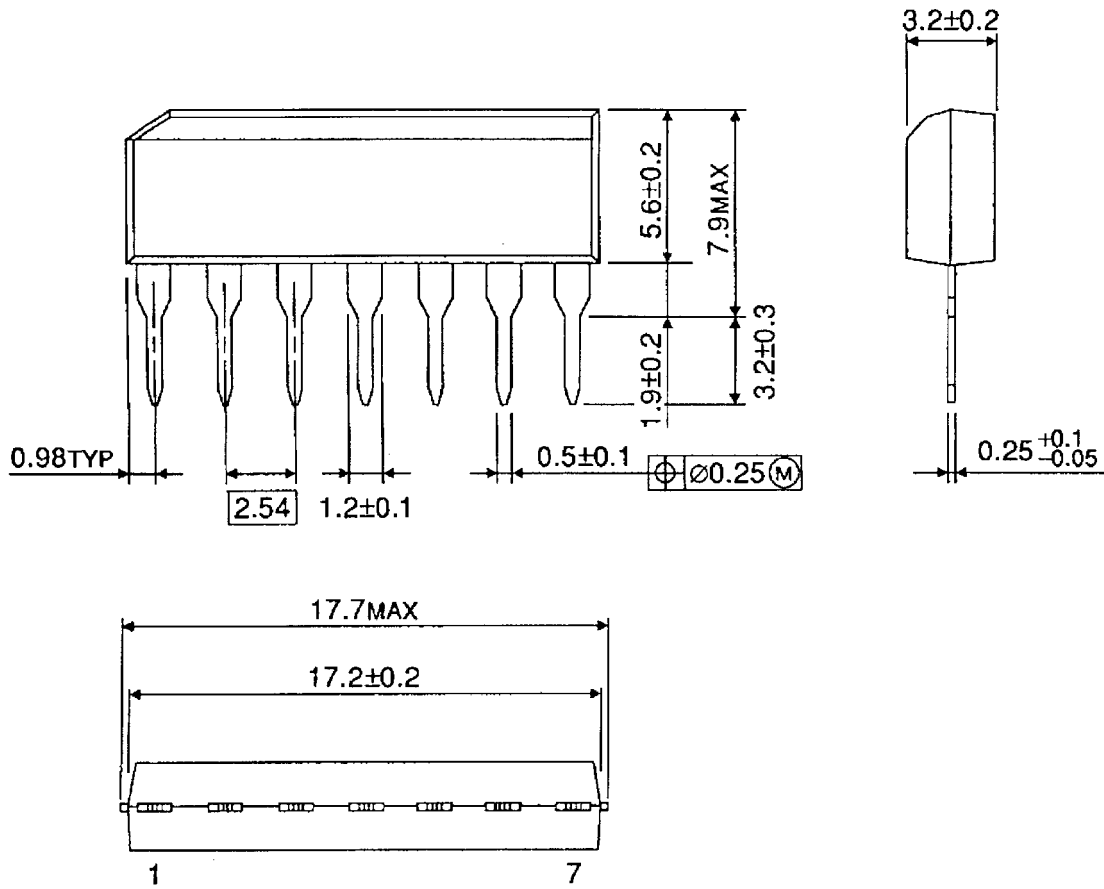

Weight: 0.7g (Typ.)

RESTRICTIONS ON PRODUCT USE

000707EAA_S

- TOSHIBA is continually working to improve the quality and reliability of its products. Nevertheless, semiconductor devices in general can malfunction or fail due to their inherent electrical sensitivity and vulnerability to physical stress. It is the responsibility of the buyer, when utilizing TOSHIBA products, to comply with the standards of safety in making a safe design for the entire system, and to avoid situations in which a malfunction or failure of such TOSHIBA products could cause loss of human life, bodily injury or damage to property.
In developing your designs, please ensure that TOSHIBA products are used within specified operating ranges as set forth in the most recent TOSHIBA products specifications. Also, please keep in mind the precautions and conditions set forth in the "Handling Guide for Semiconductor Devices," or "TOSHIBA Semiconductor Reliability Handbook" etc..
- The information contained herein is presented only as a guide for the applications of our products. No responsibility is assumed by TOSHIBA CORPORATION for any infringements of intellectual property or other rights of the third parties which may result from its use. No license is granted by implication or otherwise under any intellectual property or other rights of TOSHIBA CORPORATION or others.
- The information contained herein is subject to change without notice.