

TA8020S

DUAL VOLTAGE SENSOR

The TA8020S is an IC designed for lamp failure detection. When a lamp failure occurs, it detects the resulting lamp current change from the voltage across the detection resistor R_S . It has a reference voltage characterized by high accuracy and small temperature drift as well as a voltage comparator. It is also designed to compensate for lamp current changes due to supply voltage variations. It consists of two circuits which are supplied with power from separate pins.

FEATURES

- Two circuits served by separate power supplies
- High-performance input amplifier incorporated
- Reference voltage characterized by small temperature drift
- Built-in circuit which compensates for lamp voltage characteristic variations
- Operating temperature range : from -40 to 85°C
- Plastic SIP-9 pin

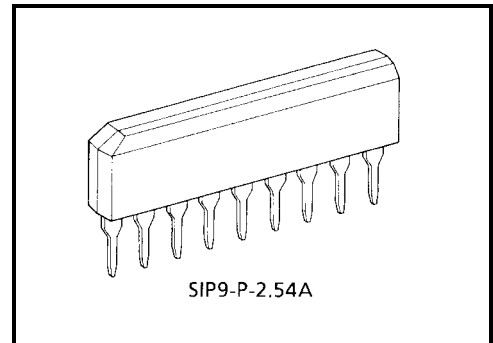

Weight: 0.92 g (typ.)

BLOCK DIAGRAM AND PIN LAYOUT

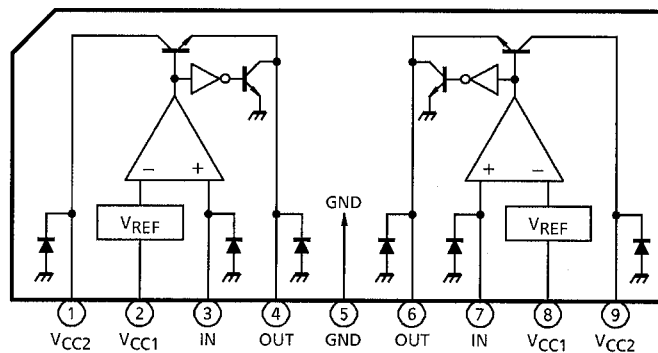

PIN DESCRIPTION

PIN No.	SYMBOL	DESCRIPTION
1, 9	V _{CC2}	Power supply pin dedicated to the output transistor. Since it is connected to V _{CC1} outside the IC, influence of output on / off on the detection voltage is low so that accurate detection is assured.
2, 8	V _{CC1}	Power supply pin for the IC. High accuracy is assured under the condition of V _{CC} = 8 to 16V.
3, 7	IN	Detection pin which leads to a differential input circuit consisting of a PNP transistor. The detected voltage is amplified ten times within the IC. The resulting voltage is fed to the differential-input PNP-transistor comparator.
4, 6	OUT	Push-pull output pin which connects to an NPN transistor. When a lamp failure is detected, this signal goes high to flow out a current for driving the external output circuit.
5	GND	Grounded

(Note: Operation mode)

Input Voltage	Output Mode
V _{IN} > V _{TH}	LOW
V _{IN} < V _{TH}	HIGH

MAXIMUM RATINGS (Ta = 25°C)

CHARACTERISTIC	SYMBOL	RATING	UNIT
Supply Voltage	V _{CC}	30	V
Power Dissipation	P _D	500	mW
Output Current	I _{OUT}	-20	mA
Input Voltage	V _{IN}	-0.3~V _{CC}	V
Operating Temperature	T _{opr}	-40~85	°C
Storage Temperature	T _{stg}	-55~150	°C
Lead Temperature-time	T _{sol}	260 (10s)	°C

ELECTRICAL CHARACTERISTICS (V_{CC} = 12V, Ta = -40 to 85°C)

CHARACTERISTIC	SYMBOL	PIN	TEST CIR-CUIT	TEST CONDITION	MIN	TYP.	MAX	UNIT
Operating Voltage	V _{CC}		—		8	—	16	V
Current Consumption	I _{CC}	V _{CC1} V _{CC2}	—	V _{CC} = 12V	—	—	7	mA
Output Voltage	V _{OUT}	OUT	—	R _L = 1kΩ(Note)	—	—	1.5	V
Leakage Current	I _{LEAK}	OUT	—	V _{OUT} = 0V	—	—	10	μA
Input Current	I _{IN}	IN	—	V _{CC} = 12V, V _{IN} = 12V	20	50	100	μA
Detection Voltage	V _{TH}	IN	—	V _{CC} = 9V	60	70	80	mV
	ΔV _{TH}		—	V _{TH} (V _{CC} = 16V) / V _{TH} (V _{CC} = 9V)	1.32	1.36	1.40	—
	ΔV _{TH} / ΔT		—	V _{CC} = 9V	-40	—	40	μV / °C

Note: V_{CC}-V_{OUT}

TYPICAL CHARACTERISTICS

(1) Detection Voltage Characteristic(V_{TH})

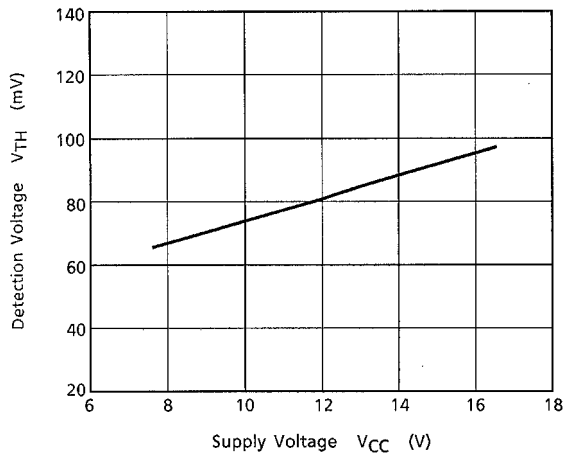

(2) Output Voltage Characteristic(V_{OUT})

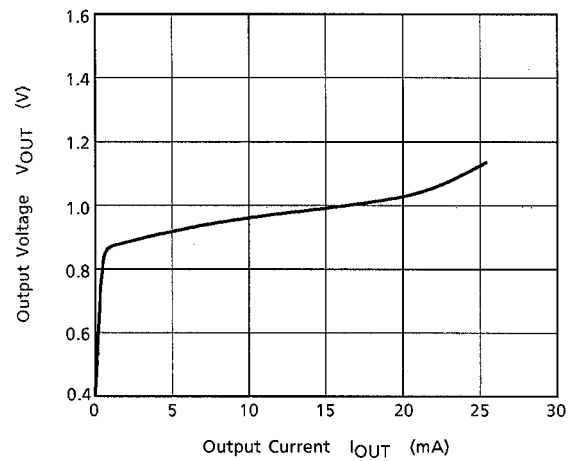

EXAMPLE OF APPLICATION CIRCUIT (120Vpeak 200ms LOAD DUMP)

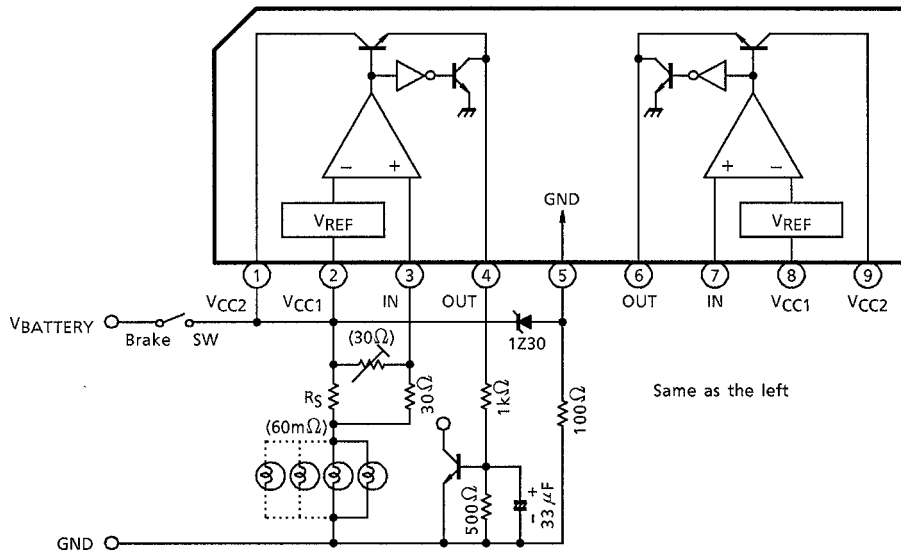

PACKAGE DIMENSIONS

SIP9-P-2.54A

Unit : mm

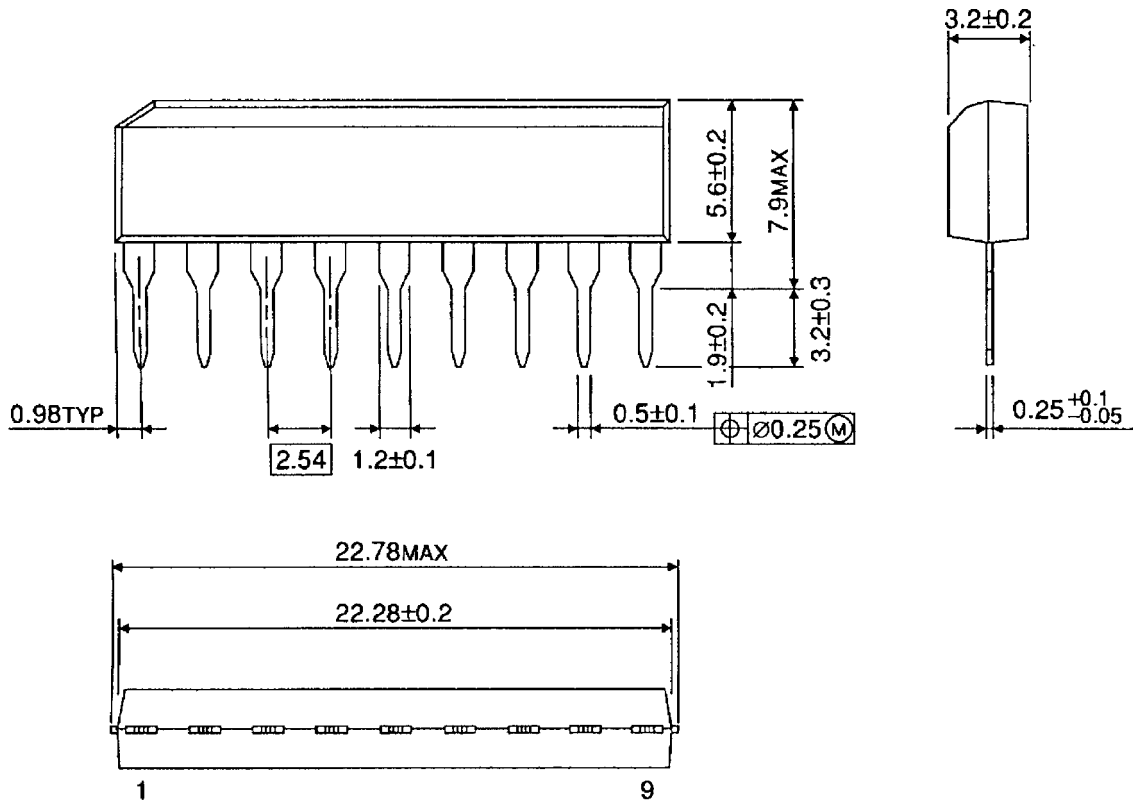

Weight: 0.92g (Typ.)

RESTRICTIONS ON PRODUCT USE

000707EAA_S

- TOSHIBA is continually working to improve the quality and reliability of its products. Nevertheless, semiconductor devices in general can malfunction or fail due to their inherent electrical sensitivity and vulnerability to physical stress. It is the responsibility of the buyer, when utilizing TOSHIBA products, to comply with the standards of safety in making a safe design for the entire system, and to avoid situations in which a malfunction or failure of such TOSHIBA products could cause loss of human life, bodily injury or damage to property.
In developing your designs, please ensure that TOSHIBA products are used within specified operating ranges as set forth in the most recent TOSHIBA products specifications. Also, please keep in mind the precautions and conditions set forth in the "Handling Guide for Semiconductor Devices," or "TOSHIBA Semiconductor Reliability Handbook" etc..
- The information contained herein is presented only as a guide for the applications of our products. No responsibility is assumed by TOSHIBA CORPORATION for any infringements of intellectual property or other rights of the third parties which may result from its use. No license is granted by implication or otherwise under any intellectual property or other rights of TOSHIBA CORPORATION or others.
- The information contained herein is subject to change without notice.