

TA8173AP

Sound Field Reproduction IC

The TA8173AP is the sound field reproduction IC developed for use on such stereo equipment as radio cassette tape recorder, multivoise TV set. etc.

This IC has made it possible to reproduce stereophonic sound with more presence by forcing difference signals of R-ch and L-ch to delay and applying these signals to R-ch and L-ch again.

Features

- Built-in 4 stages of the lagging phase filter
- Built-in NORMAL/DELAY switch
- Operating supply voltage range
: $V_{CC(opr)} = 4\sim 12\text{ V}$ ($T_a = 25^\circ\text{C}$)

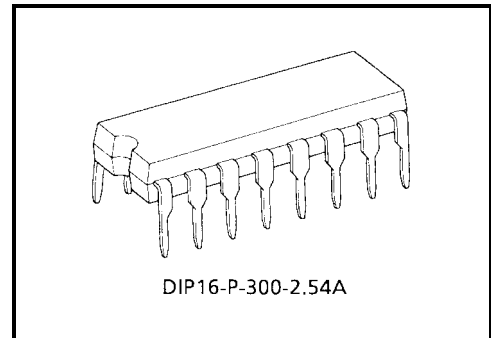

Weight: 1.00 g (typ.)

Block Diagram

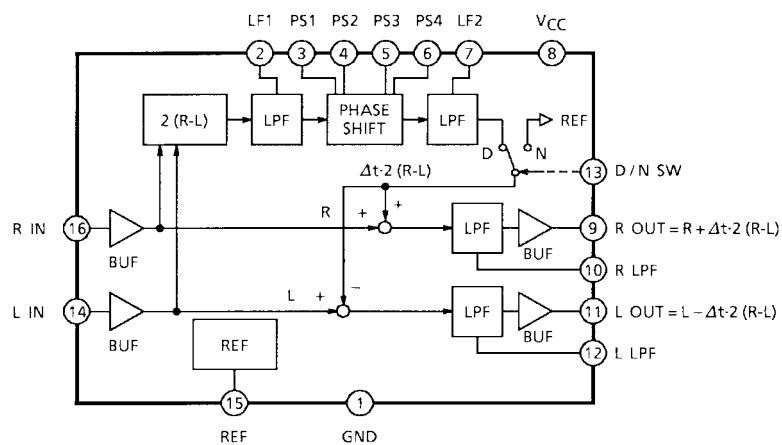

Cautions for Use

1. D/N (delay/normal) switch

The Pin 13 is the delay/normal mode selector switch. The delay mode/normal mode control voltage ranges are as follows :

V_{CC} = 5 V, Ta = 25°C

Delay mode	V ₁₃ = 2.0 V~V _{CC} or open
Normal mode	V ₁₃ = 0 V~0.2 V

If the output pop noise is generated when the delay/normal mode is Switched by pin 13, the Noise level can be reduced by smoothing current with a capacitor and resistor connected to pin 13 externally as shown in the test circuit diagram.

The recommended values are C = 33 μF and R = 3 kΩ.

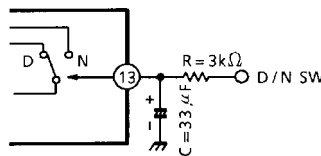

2. Delay system signal level

This IC delays phase of the difference signal (R-L) of the R (PIN 16 input) signal and L (PIN 14 input) signal and adds it to the R and L signals again. This delay system signal level has been set at 2 (R·L) in the standard circuit. However, as it is possible to reduce this signal level by externally connected parts. Set an optimum value through a listening test, etc. as shown below.

Connect a resistor from the LPF output PIN 2 or 7 to the REF PIN 15 as illustrated below. As a 10 kΩ is seen in the LPF output PIN, it is possible to attenuate the delay system signal level by dividing resistance with the external resistor R_x.

In this case as the time constant of the LPF changes when the R_x is connected, decide the LPF's time constant by (10 kΩ//R_x)·C_x again after deciding the R_x.

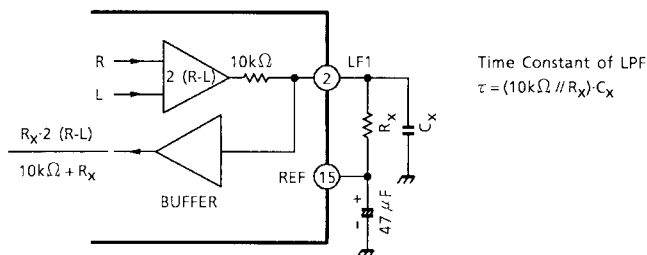

3. Delay system signal phase delay circuit

In the phase delay circuit of this IC, 4 stages of the block shown below are connected in series. Decide a time constant by the external C_D and total phase delay by the number of stages to be used.

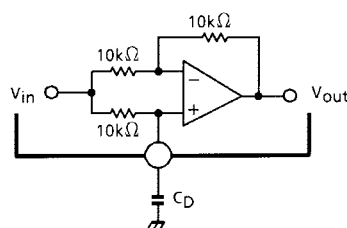

$$\frac{V_{out}}{V_{in}} = \frac{1 - j2\pi f \cdot 10k\Omega \cdot C_D}{1 + j2\pi f \cdot 10k\Omega \cdot C_D}$$

$$\phi = -2 \tan^{-1} (2\pi f \cdot 10k\Omega \cdot C)$$

4. Oscillation stability

In the test circuit diagram, the capacitor ($C = 330 \text{ pF}$) and the resistor ($R = 1 \text{ k}\Omega$) connected to the output pins 9 and 11 consist of the LPF for preventing frequency parasitic oscillation. If this LPF is not inserted in the circuit, weak oscillation of several MHz may be generated and therefore, user is advised to surely connect this LPF.

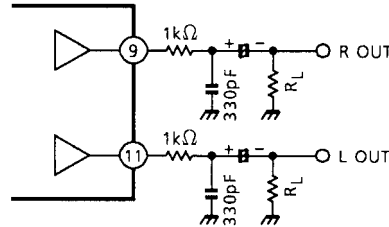

Maximum Ratings (Ta = 25°C)

Characteristics	Symbol	Rating	Unit
Supply voltage	V _{CC}	14	V
Power dissipation	P _D (Note)	750	mW
Operating temperature	T _{opr}	-25~75	°C
Storage temperature	T _{stg}	-55~150	°C

Note: Derated above Ta = 25°C in the proportion of 6 mW/°C.

Electrical Characteristics

(unless otherwise specified, V_{CC} = 5 V, f = 1 kHz, R_L = 10 kΩ, Ta = 25°C, Normal mode)

Characteristics	Symbol	Test Circuit	Test Condition	Min	Typ.	Max	Unit
Quiescent current	I _{CCQ}	—	V _{in} = 0	—	6	10	mA
Voltage gain 1	G _{v1}	—	—	-3	-1	1	dB
Voltage gain ratio	ΔG _v	—	—	-1	0	1	dB
Voltage gain 2	G _{v2}	—	Delay mode, f = 100 Hz	6	8	10	dB
Maximum output voltage	V _{om}	—	THD = 1%	—	1.0	—	V _{rms}
Total harmonic distortion	THD	—	V _{out} = 300 mV _{rms}	—	0.02	0.2	%
Output noise voltage 1	V _{no1}	—	Normal mode, DIN AUDIO Filter IN	—	10	40	μV _{rms}
Output noise voltage 2	V _{no2}	—	Delay mode, DIN AUDIO Filter IN	—	17	—	μV _{rms}
Channel separation ratio	Sep.	—	V _{out} = 1 V _{rms}	—	-55	—	dB
Ripple rejection 1	R.R.1	—	Normal mode, f = 100 Hz, V _{ripple} = 0.316 V _{rms} (-10dBV)	—	-55	—	dB
Ripple rejection 2	R.R.2	—	Delay mode, f = 100 Hz, V _{ripple} = 0.316 V _{rms} (-10dBV)	—	-45	—	dB
Input resistance	R _{IN}	—	—	—	33	—	kΩ

Test Circuit

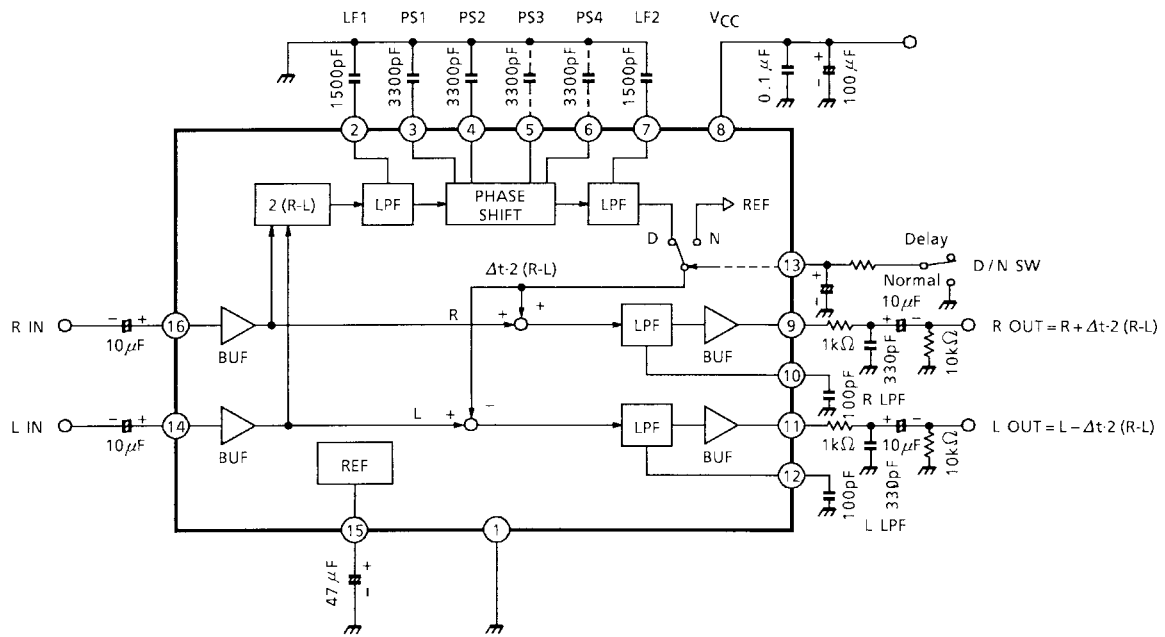

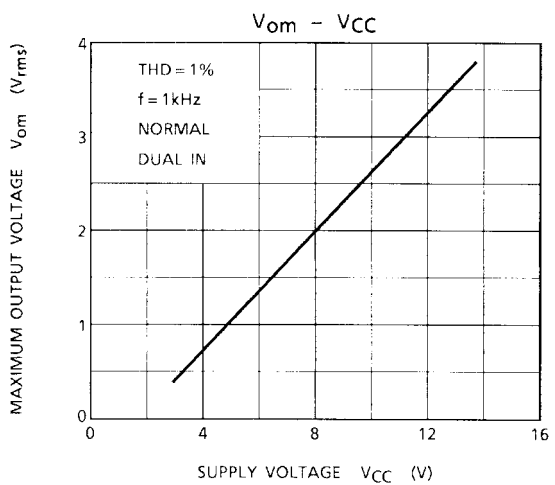
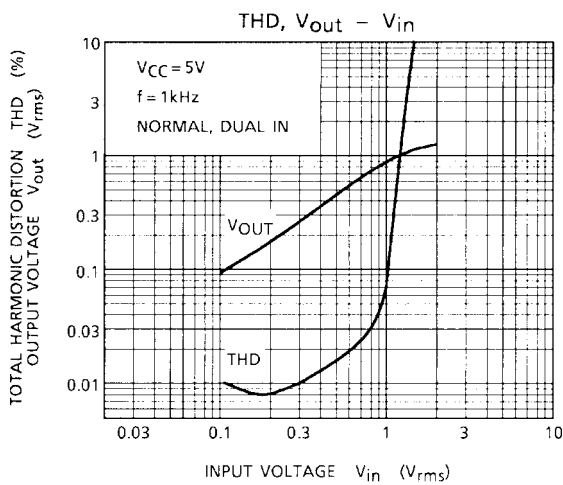
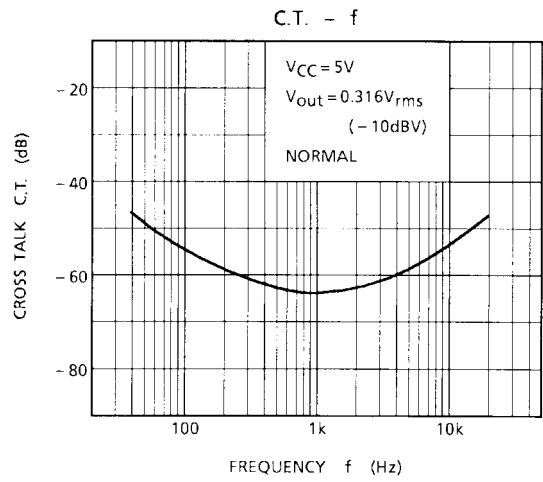
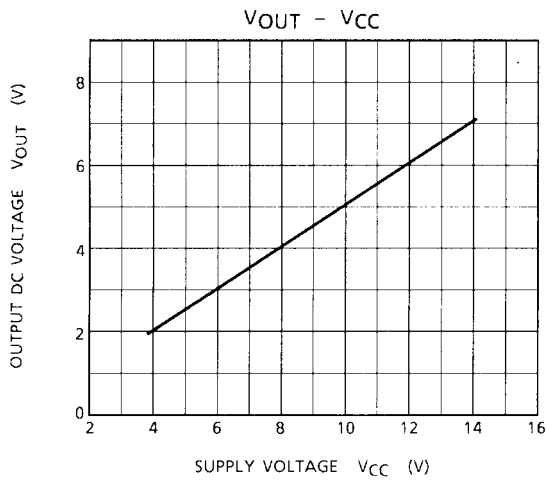
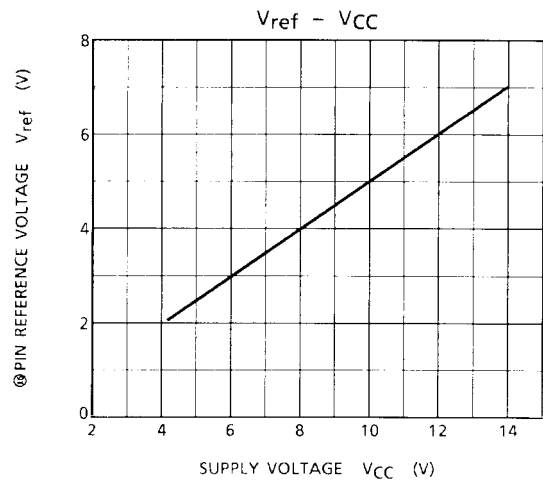
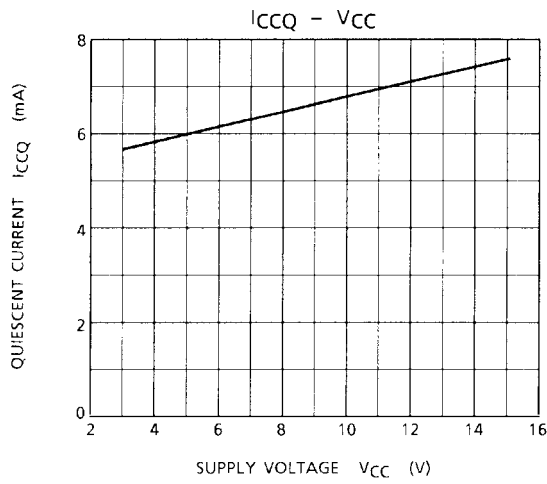

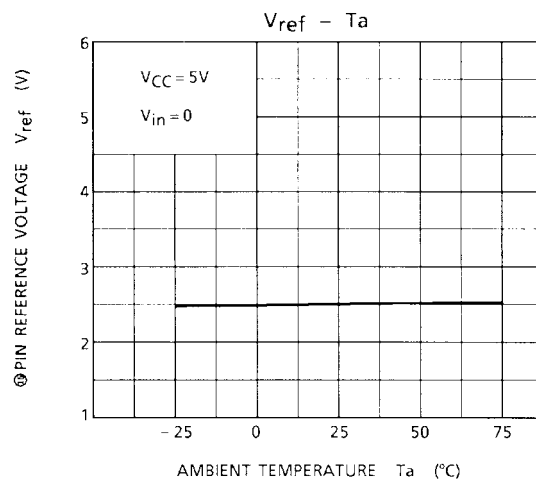
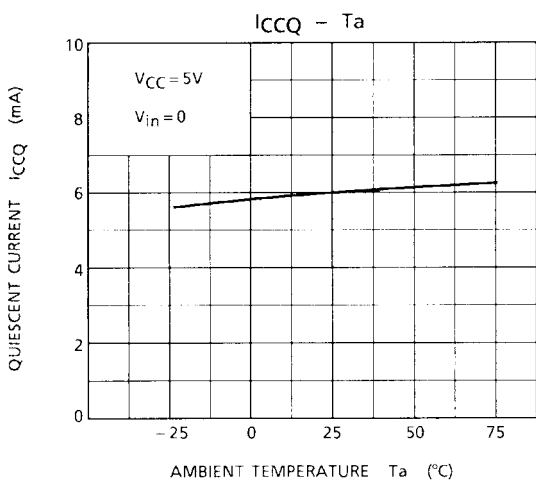
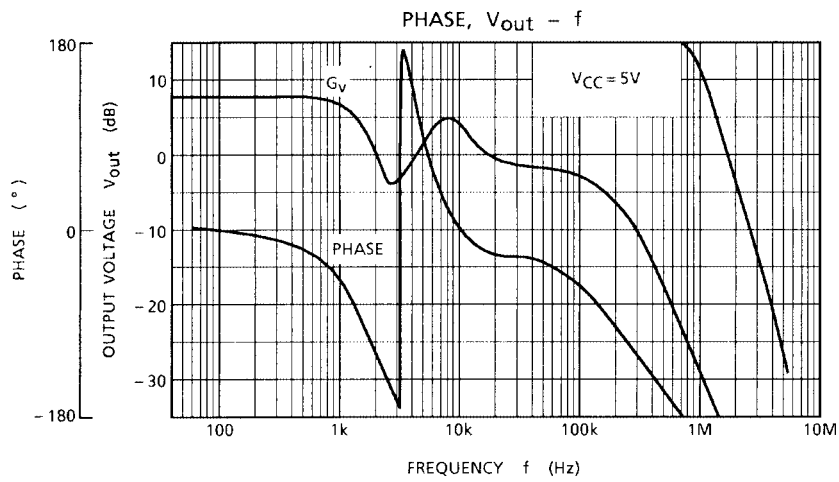
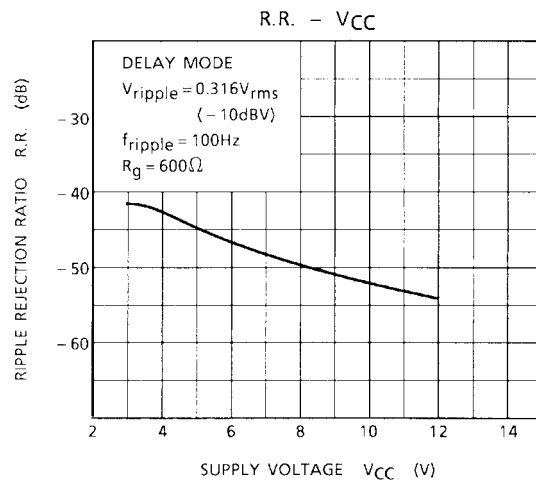
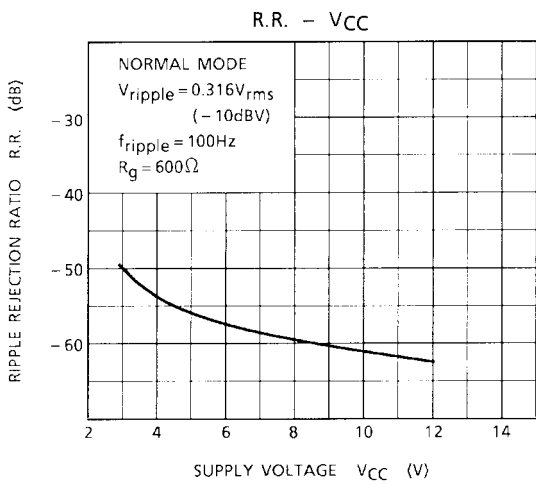

Package Dimensions

DIP16-P-300-2.54A

Unit : mm

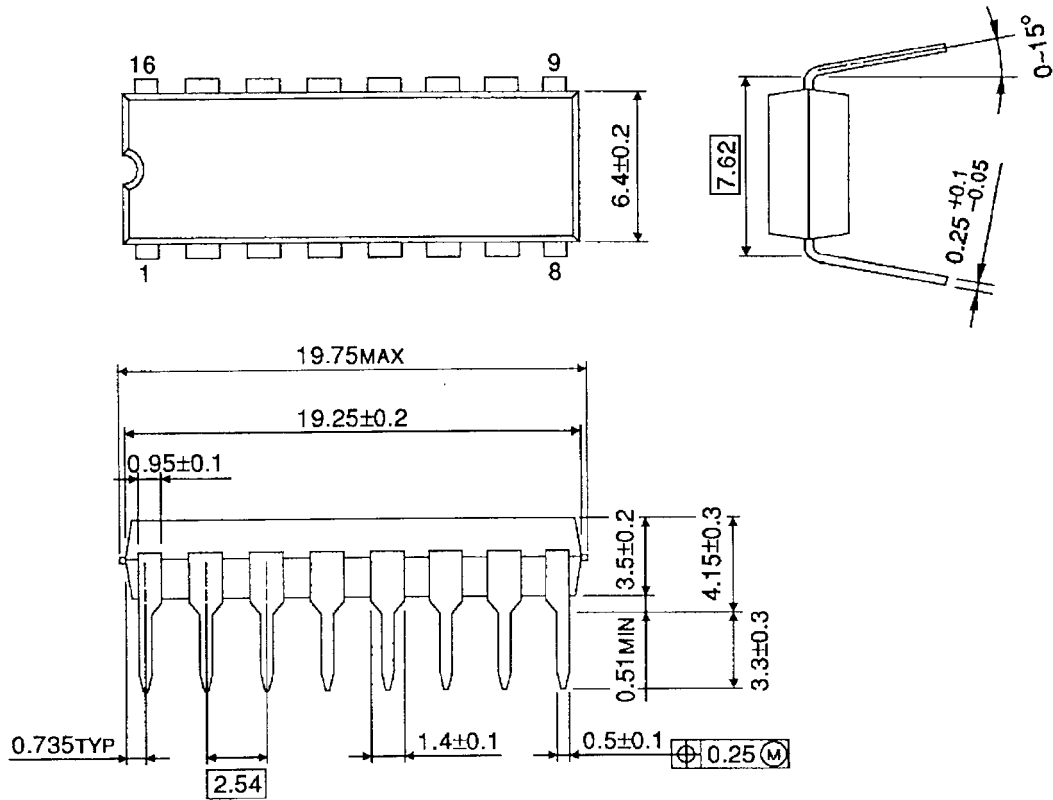

Weight: 1.00 g (typ.)

RESTRICTIONS ON PRODUCT USE

000707EBA

- TOSHIBA is continually working to improve the quality and reliability of its products. Nevertheless, semiconductor devices in general can malfunction or fail due to their inherent electrical sensitivity and vulnerability to physical stress. It is the responsibility of the buyer, when utilizing TOSHIBA products, to comply with the standards of safety in making a safe design for the entire system, and to avoid situations in which a malfunction or failure of such TOSHIBA products could cause loss of human life, bodily injury or damage to property.
In developing your designs, please ensure that TOSHIBA products are used within specified operating ranges as set forth in the most recent TOSHIBA products specifications. Also, please keep in mind the precautions and conditions set forth in the "Handling Guide for Semiconductor Devices," or "TOSHIBA Semiconductor Reliability Handbook" etc..
- The TOSHIBA products listed in this document are intended for usage in general electronics applications (computer, personal equipment, office equipment, measuring equipment, industrial robotics, domestic appliances, etc.). These TOSHIBA products are neither intended nor warranted for usage in equipment that requires extraordinarily high quality and/or reliability or a malfunction or failure of which may cause loss of human life or bodily injury ("Unintended Usage"). Unintended Usage include atomic energy control instruments, airplane or spaceship instruments, transportation instruments, traffic signal instruments, combustion control instruments, medical instruments, all types of safety devices, etc.. Unintended Usage of TOSHIBA products listed in this document shall be made at the customer's own risk.
- The products described in this document are subject to the foreign exchange and foreign trade laws.
- The information contained herein is presented only as a guide for the applications of our products. No responsibility is assumed by TOSHIBA CORPORATION for any infringements of intellectual property or other rights of the third parties which may result from its use. No license is granted by implication or otherwise under any intellectual property or other rights of TOSHIBA CORPORATION or others.
- The information contained herein is subject to change without notice.