

TOSHIBA Bipolar Linear Integrated Circuit Silicon Monolithic

# TA8263BH

## Max Power 43 W BTL × 4 ch Audio Power IC

The TA8263BH is 4 ch BTL audio power amplifier for car audio application.

This IC can generate more high power:  $POUT_{MAX} = 43\text{ W}$  as it is included the pure complementary PNP and NPN transistor output stage.

It is designed low distortion ratio for 4 ch BTL audio power amplifier, built-in stand-by function, muting function, and diagnosis circuit which can detect output to  $V_{CC}/GND$  short, output offset voltage and over voltage input mode.

Additionally, the AUX amplifier and various kind of protector for car audio use are built-in.

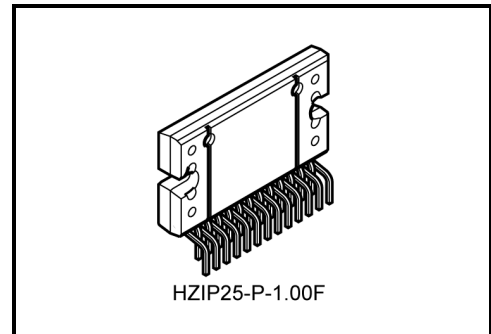

Weight: 7.7 g (typ.)

## Features

- High power:  $POUT_{MAX} (1) = 43\text{ W}$  (typ.)  
 ( $V_{CC} = 14.4\text{ V}$ ,  $f = 1\text{ kHz}$ , JEITA max,  $R_L = 4\ \Omega$ )  
 :  $POUT_{MAX} (2) = 40\text{ W}$  (typ.)  
 ( $V_{CC} = 13.7\text{ V}$ ,  $f = 1\text{ kHz}$ , JEITA max,  $R_L = 4\ \Omega$ )  
 :  $POUT (1) = 28\text{ W}$  (typ.)  
 ( $V_{CC} = 14.4\text{ V}$ ,  $f = 1\text{ kHz}$ , THD = 10%,  $R_L = 4\ \Omega$ )  
 :  $POUT (2) = 24\text{ W}$  (typ.)  
 ( $V_{CC} = 13.2\text{ V}$ ,  $f = 1\text{ kHz}$ , THD = 10%,  $R_L = 4\ \Omega$ )
- Built-in diagnosis circuit (pin 25)
- Low distortion ratio: THD = 0.02% (typ.)  
 ( $V_{CC} = 13.2\text{ V}$ ,  $f = 1\text{ kHz}$ ,  $POUT = 5\text{ W}$ ,  $R_L = 4\ \Omega$ )
- Low noise:  $V_{NO} = 0.10\text{ mV}_{rms}$  (typ.)  
 ( $V_{CC} = 13.2\text{ V}$ ,  $R_g = 0\ \Omega$ ,  $GV = 26\text{ dB}$ ,  $BW = 20\text{ Hz} \sim 20\text{ kHz}$ )
- Built-in stand-by switch function (pin 4)
- Built-in muting function (pin 22)
- Built-in AUX amplifier from single input to 4 channels output (pin 16)
- Built-in various protection circuit  
 : Thermal shut down, over voltage, out to GND, out to  $V_{CC}$ , out to out short
- Operating supply voltage:  $V_{CC (opr)} = 9 \sim 18\text{ V}$

## Block Diagram

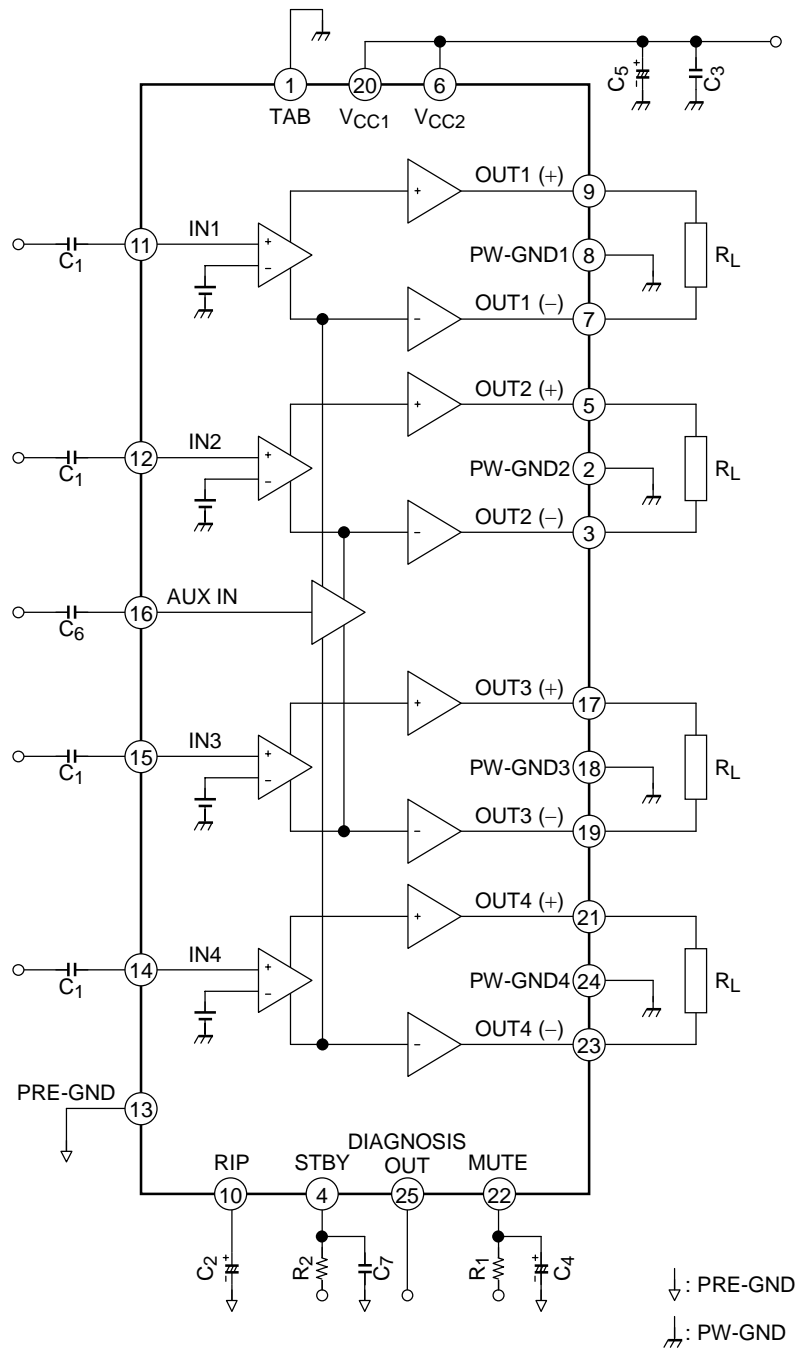

**Caution and Application Method**  
 (Description is made only on the single channel.)

**1. Voltage Gain Adjustment**

This IC has no NF (negative feedback) terminals. Therefore, the voltage gain can't adjusted, but it makes the device a space and total costs saver.

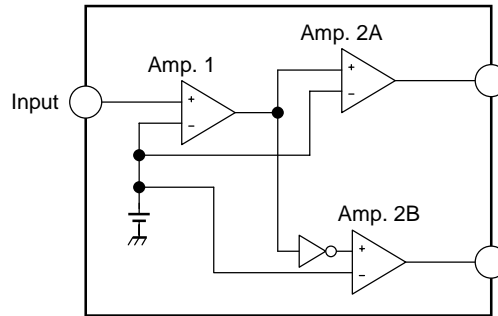

**Figure 1 Block Diagram**

The voltage gain of Amp.1 :  $GV_1 = 0 \text{ dB}$   
 The voltage gain of Amp.2A, B :  $GV_2 = 20 \text{ dB}$   
 The voltage gain of BLT Connection :  $GV \text{ (BTL)} = 6 \text{ dB}$   
 Therefore, the total voltage gain is decided by expression below.  
 $GV = GV_1 + GV_2 + GV \text{ (BTL)} = 0 + 20 + 6 = 26 \text{ dB}$

**2. Stand-by SW Function (pin 4)**

By means of controlling pin 4 (stand-by terminal) to high and low, the power supply can be set to ON and OFF. The threshold voltage of pin 4 is set at about  $3V_{BE}$  (typ.), and the power supply current is about  $2 \mu\text{A}$  (typ.) at the stand-by state.

**Control Voltage of pin 4:  $V_{SB}$**

Stand-by	Power	$V_{SB}$ (V)
ON	OFF	0~1.5
OFF	ON	$3 \sim V_{CC}$

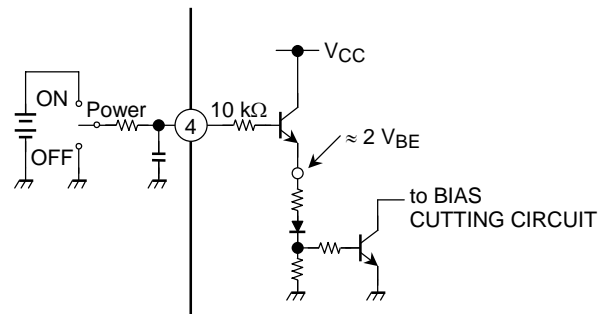

**Figure 2 With pin 4 set to High, Power is turned ON**

**Adjustage of Stand-by SW**

- (1) Since  $V_{CC}$  can directly be controlled to ON or OFF by the microcomputer, the switching relay can be omitted.
- (2) Since the control current is microscopic, the switching relay of small current capacity is satisfactory for switching

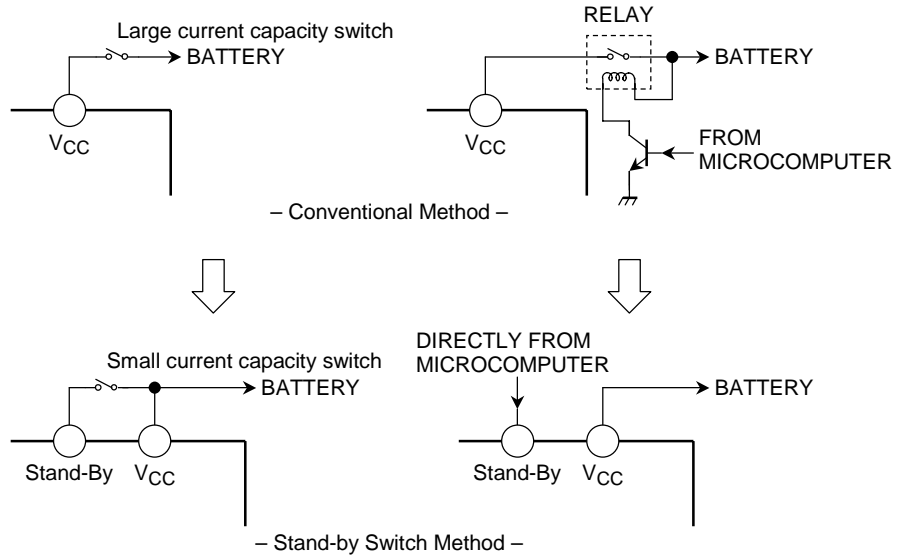

Figure 3

3. Muting Function (pin 22)

By means of controlling pin 22 less than 0.5 V, it can make the audio muting condition.

The muting time constant is decided by  $R_1$  and  $C_4$  and these parts is related the pop noise at power ON/OFF.

The series resistance;  $R_1$  must be set up less than 10 k $\Omega$  to get enough muting attenuation.

The muting function have to be controlled by a transistor, FET and microcontroller port which has  $I_{MUTE} > 250 \mu A$  ability.

Pin 22 terminal voltage has the temperature characteristics of 4.6 V (low temperature) to 3.2 V (high temperature).

Therefore, it is need to design with attention as using the microcontroller of which operating voltage is less than 5 V.

Terminal 22 may not be pulled up and shall be controlled by OPEN/LOW.

When it is obliged to do, it must be pulled up via diode, because it has to defend flowing reverse current to internal circuit of pin 22.

<Recommended Application>

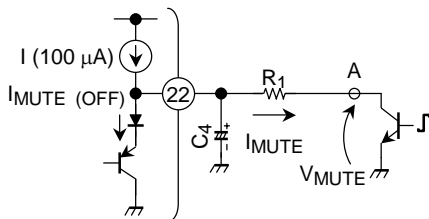

<Application for pulled up>

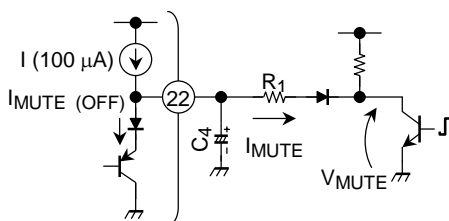

Figure 4 Muting Function

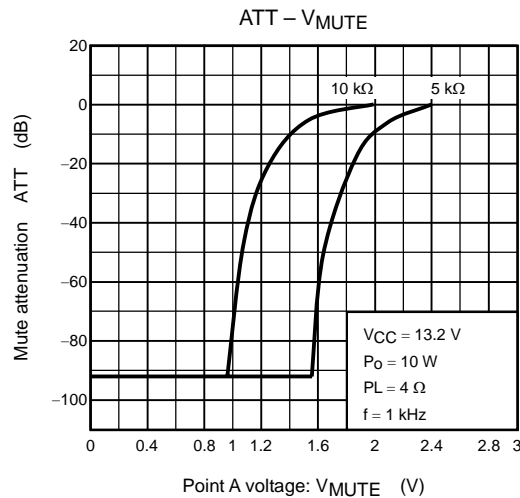

Figure 5 Mute Attenuation -  $V_{MUTE}$  (V)

**4. AUX Input (pin 16)**

The pin 16 is for input terminal of AUX amplifier.

The total gain is 0dB by using of AUX amplifier.

Therefore, the  $\mu$ -COM can directly drive the AUX amplifier.

BEEP sound or voice synthesizer signal can be input to pin 16 directly.

When AUX function is not used, this pin must be connected to PRE-GND (pin 13) via a capacitor.

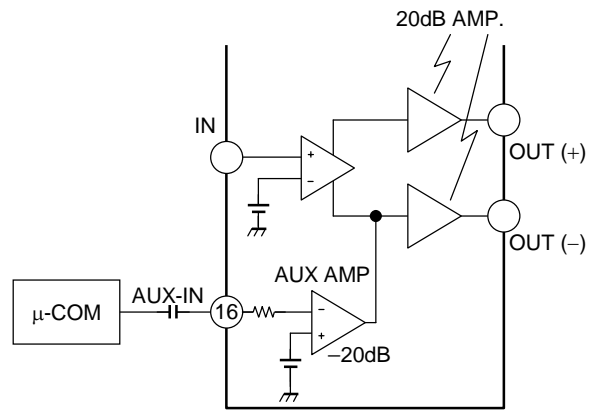

**Figure 6 AUX Input**

**5. Diagnosis Output (pin 25)**

This diagnosis output terminal of pin 25 has open collector output structure on chip as shown in Figure 7. In case diagnosis circuit that detect unusual case is operated, NPN transistor (Q1) or (Q2) is turned on.

It is possible to protect all the system of apparatus as well as power IC protection.

In case of being unused this function, use this IC as open-connection on pin 25.

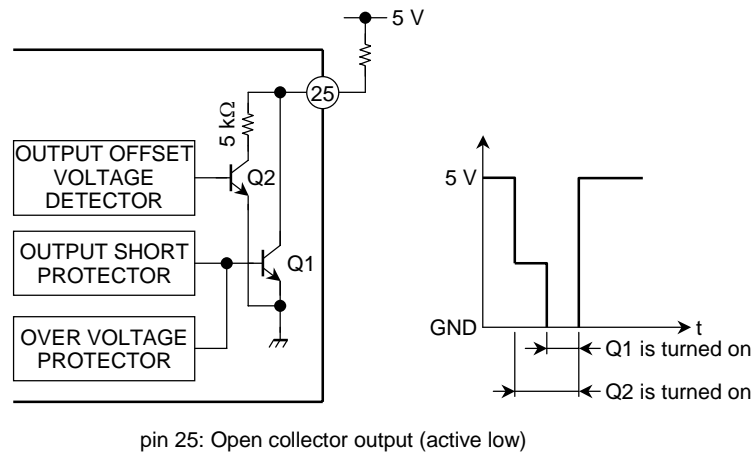

pin 25: Open collector output (active low)

**Figure 7 Self Diagnosis Output**

**5.1 In Case of Shorting Output to V<sub>CC</sub>/GND or Over Voltage Power Supplied**

NPN transistor (Q1) is turned on.

Threshold of over voltage protection: V<sub>CC</sub> = 22 V (typ.)

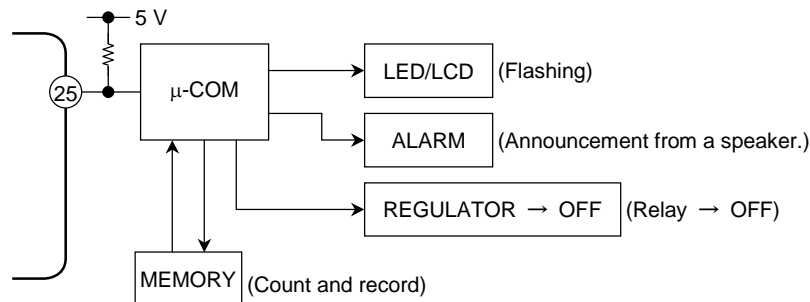

**Figure 8 Application 1**

**5.2 In Case of Shorting Q1 Output to Output**

NPN transistor (Q1) is turned on and off in response to the input signal voltage.

**5.3 In Case of Appearing Output Offset Voltage by Generating a Large Leakage Current on the Input Capacitor etc.**

NPN transistor (Q2) is turned on while the inverted output voltage level become less than the threshold level of output offset voltage detector.

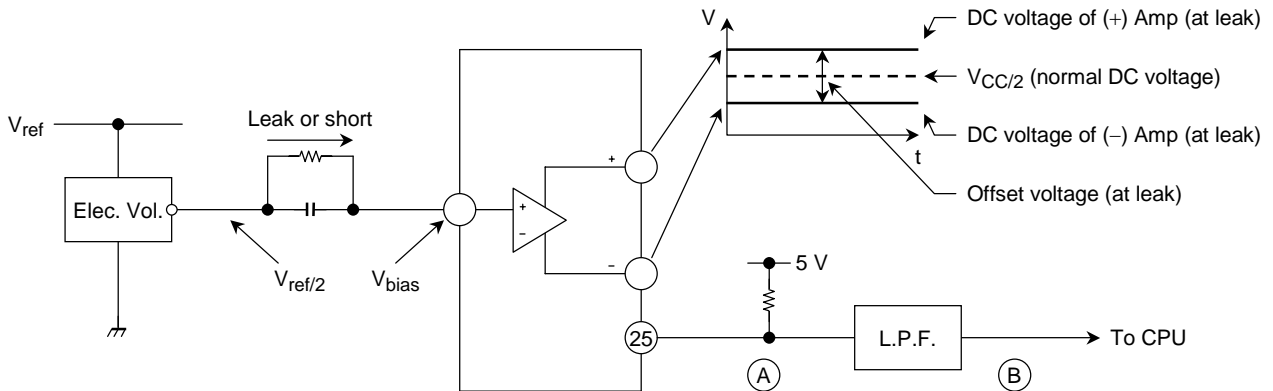

\*: It is possible to detect the abnormal output offset which is appeared by the large leakage of the input capacitor at  $V_{ref}/2 > V_{bias}$  (about 1.4 V)

**Figure 9 Application and Detection Mechanism**

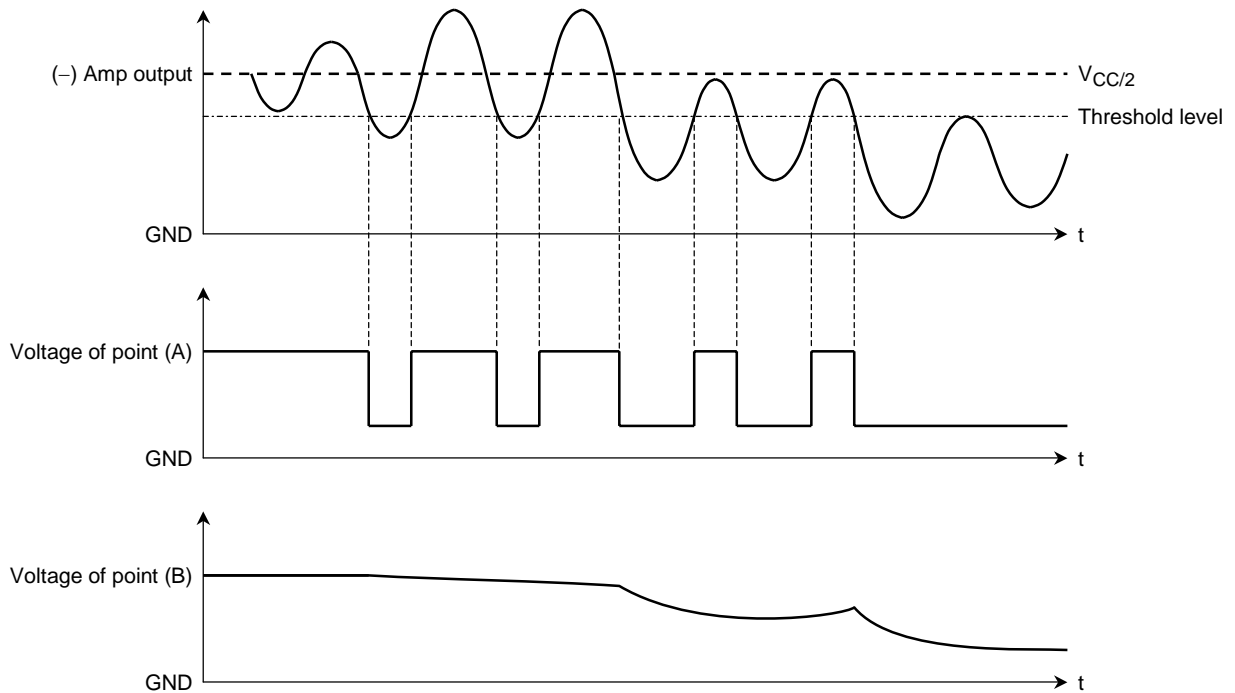

**Figure 10 Wave Form**

## Maximum Ratings (Ta = 25°C)

Characteristics	Symbol	Rating	Unit
Peak supply voltage (0.2 s)	V <sub>CC</sub> (surge)	50	V
DC supply voltage	V <sub>CC</sub> (DC)	25	V
Operation supply voltage	V <sub>CC</sub> (opr)	18	V
Output current (peak)	I <sub>O</sub> (peak)	9	A
Power dissipation	P <sub>D</sub> (Note1)	125	W
Operation temperature	T <sub>opr</sub>	-40~85	°C
Storage temperature	T <sub>stg</sub>	-55~150	°C

Note1: Package thermal resistance  $\theta_{j-T} = 1^{\circ}\text{C/W}$  (typ.)  
(Ta = 25°C, with infinite heat sink)

## Electrical Characteristics (unless otherwise specified V<sub>CC</sub> = 13.2 V, f = 1 kHz, R<sub>L</sub> = 4 Ω, Ta = 25°C)

Characteristics	Symbol	Test Circuit	Test Condition	Min	Typ.	Max	Unit
Quiescent current	I <sub>CCQ</sub>	—	V <sub>IN</sub> = 0	—	200	400	mA
Output power	P <sub>OUT</sub> MAX (1)	—	V <sub>CC</sub> = 14.4 V, max Power	—	43	—	W
	P <sub>OUT</sub> MAX (2)	—	V <sub>CC</sub> = 13.7 V, max Power	—	40	—	
	P <sub>OUT</sub> (1)	—	V <sub>CC</sub> = 14.4 V, THD = 10%	—	28	—	
	P <sub>OUT</sub> (2)	—	THD = 10%	22	24	—	
Total harmonic distortion	THD	—	P <sub>OUT</sub> = 5 W	—	0.02	0.2	%
Voltage gain	G <sub>V</sub>	—	V <sub>OUT</sub> = 0.775 V <sub>rms</sub> (0dBm)	24	26	28	dB
Voltage gain ratio	ΔG <sub>V</sub>	—	V <sub>OUT</sub> = 0.775 V <sub>rms</sub> (0dBm)	-1.0	0	1.0	
Output noise voltage	V <sub>NO</sub> (1)	—	R <sub>g</sub> = 0 Ω, DIN45405	—	0.12	—	mV <sub>rms</sub>
	V <sub>NO</sub> (2)	—	R <sub>g</sub> = 0 Ω, BW = 20 Hz~20 kHz	—	0.10	0.35	
Ripple rejection ratio	R.R.	—	f <sub>rip</sub> = 100 Hz, R <sub>g</sub> = 620 Ω V <sub>rip</sub> = 0.775 V <sub>rms</sub> (0dBm)	40	50	—	dB
Cross talk	C.T.	—	R <sub>g</sub> = 620 Ω V <sub>OUT</sub> = 0.775 V <sub>rms</sub> (0dBm)	—	65	—	dB
Output offset voltage	V <sub>OFFSET</sub>	—	—	-150	0	+150	mV
Input resistance	R <sub>IN</sub>	—	—	—	90	—	kΩ
Stand-by current	I <sub>SB</sub>	—	Stand-by condition	—	2	10	μA
Stand-by control voltage	V <sub>SB</sub> H	—	Power: ON	3.0	—	V <sub>CC</sub>	V
	V <sub>SB</sub> L	—	Power: OFF	0	—	1.5	
Mute control voltage (Note2)	V <sub>M</sub> H	—	Mute: OFF	Open			—
	V <sub>M</sub> L	—	Mute: ON, R <sub>1</sub> = 10 kΩ	0	—	0.5	V
Mute attenuation	ATT M	—	Mute: ON, V <sub>OUT</sub> = 7.75 V <sub>rms</sub> (20dBm) at Mute: OFF.	80	90	—	dB

Note2: Muting function have to be controlled by open and low logic, which logic is a transistor, FET and μ-COM port of I<sub>MUTE</sub> > 250 μA ability.  
This means than the mute control terminal : pin 22 must not be pulled-up.

## Test Circuit

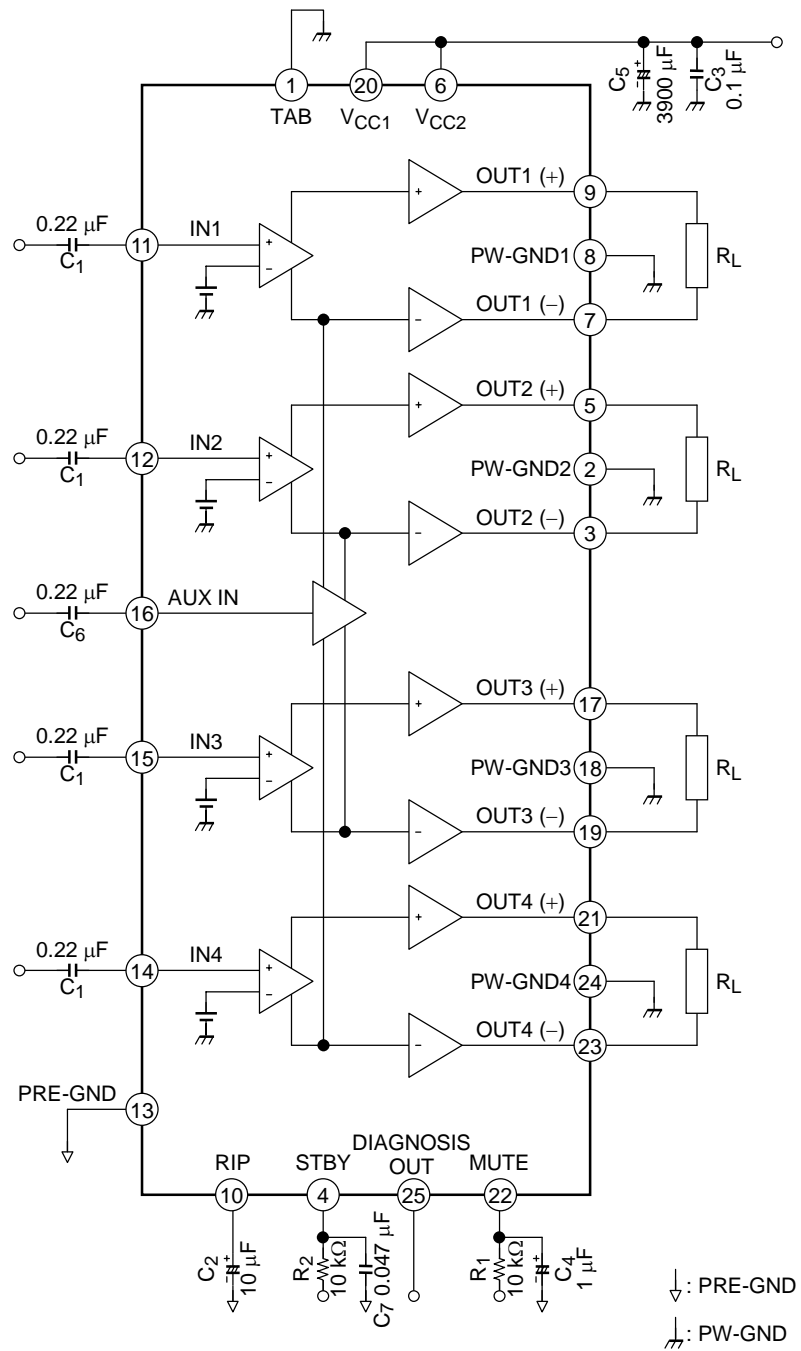



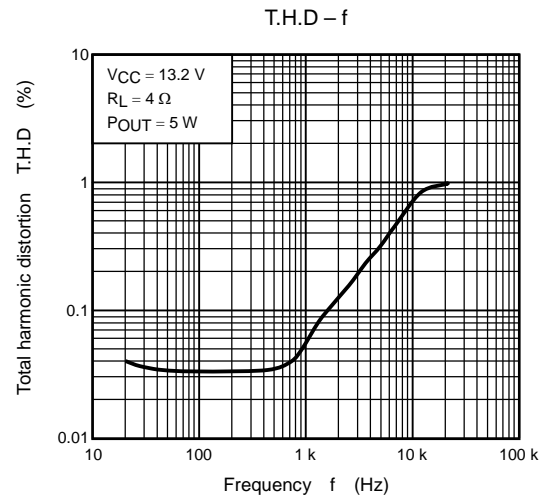
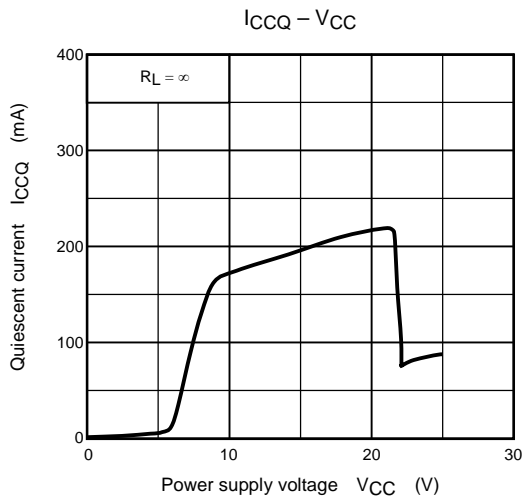
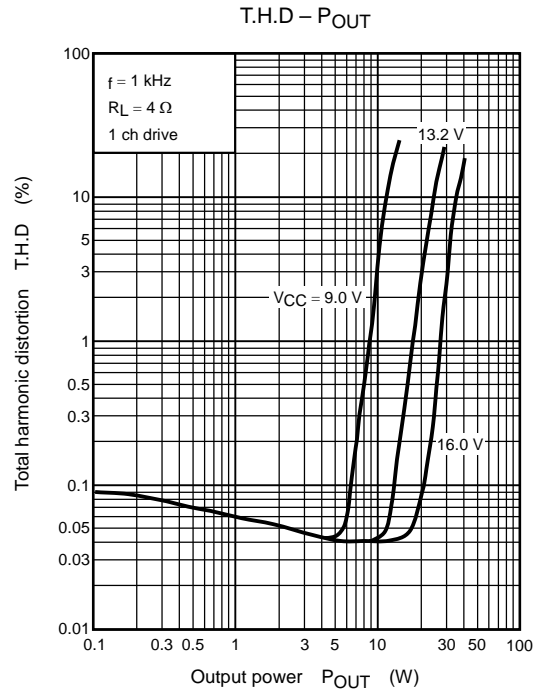
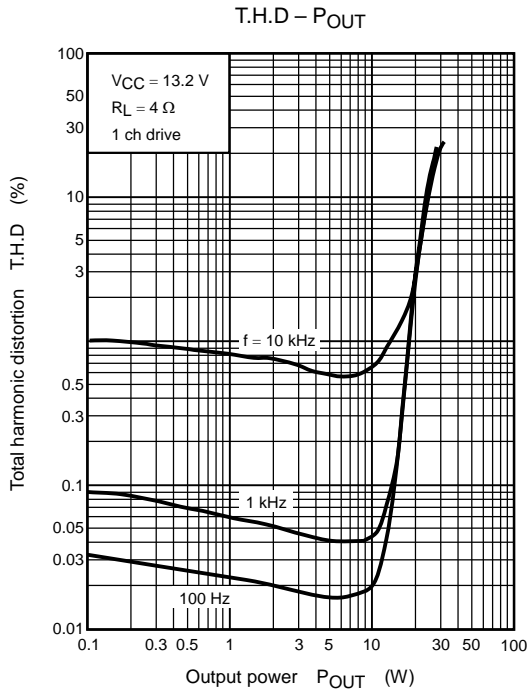

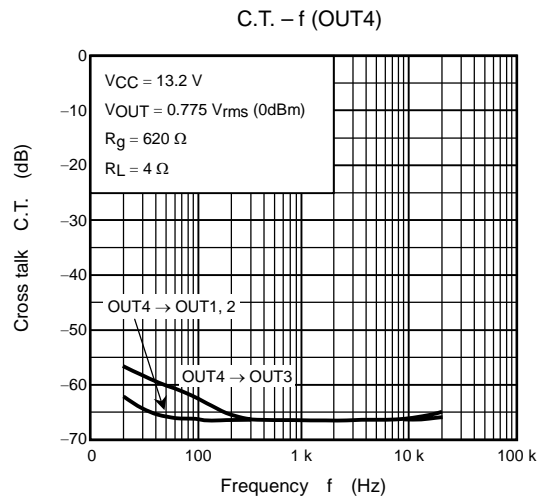
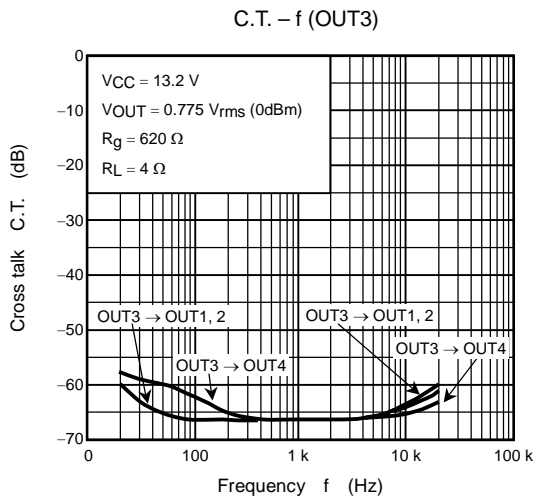
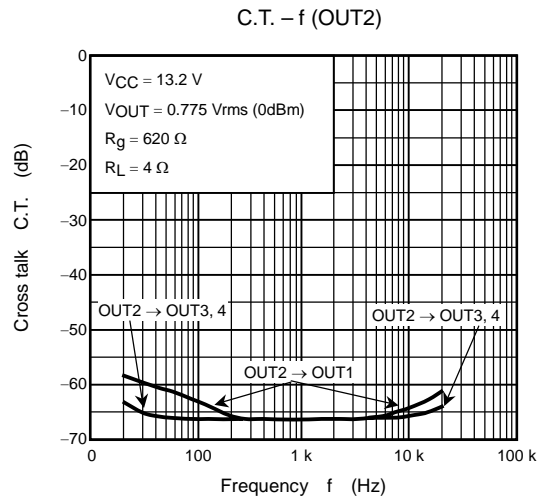
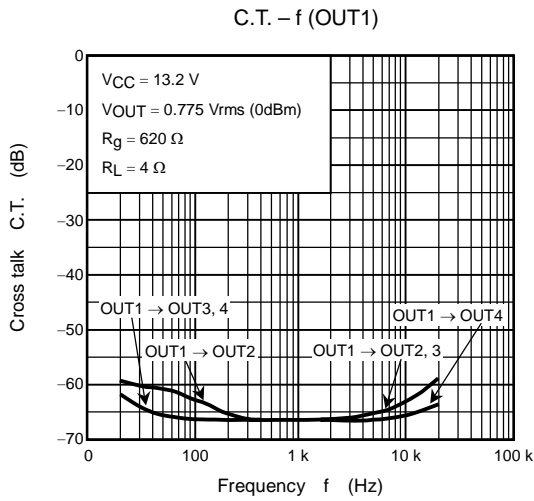
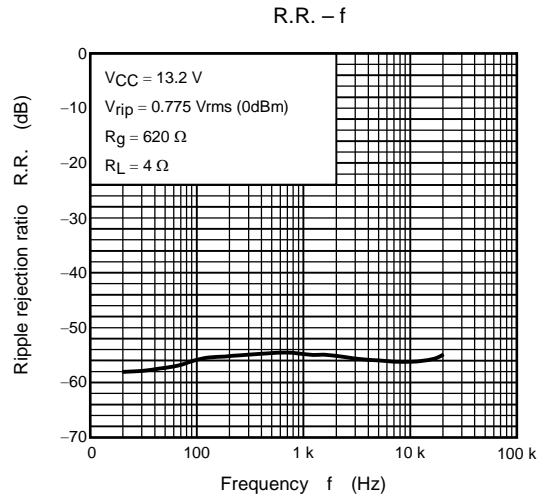
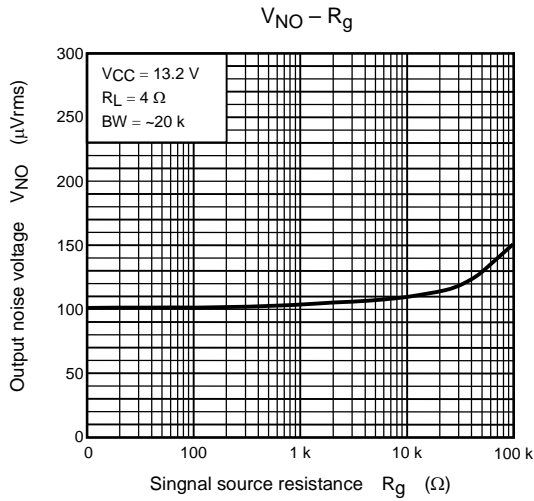

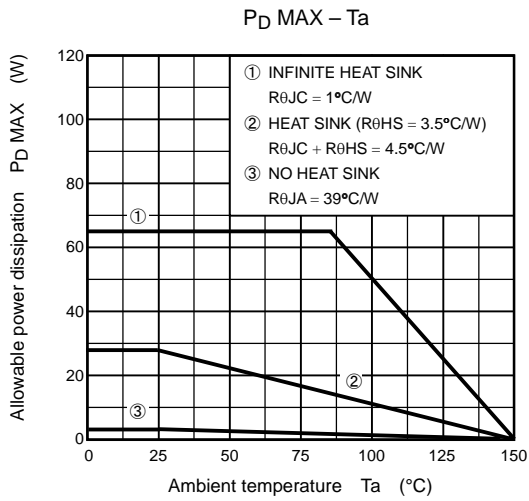
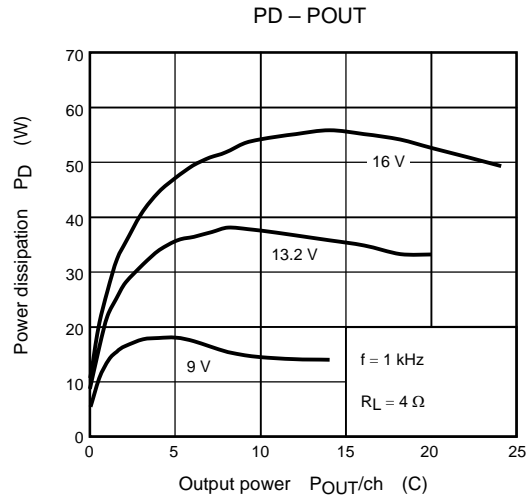
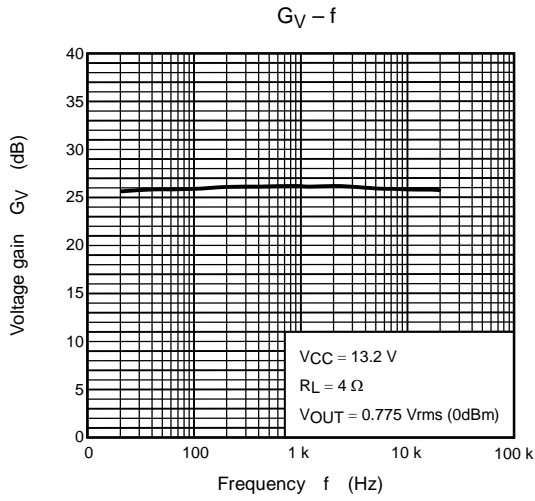

## Package Dimensions

HZIP25-P-1.00F

Unit: mm

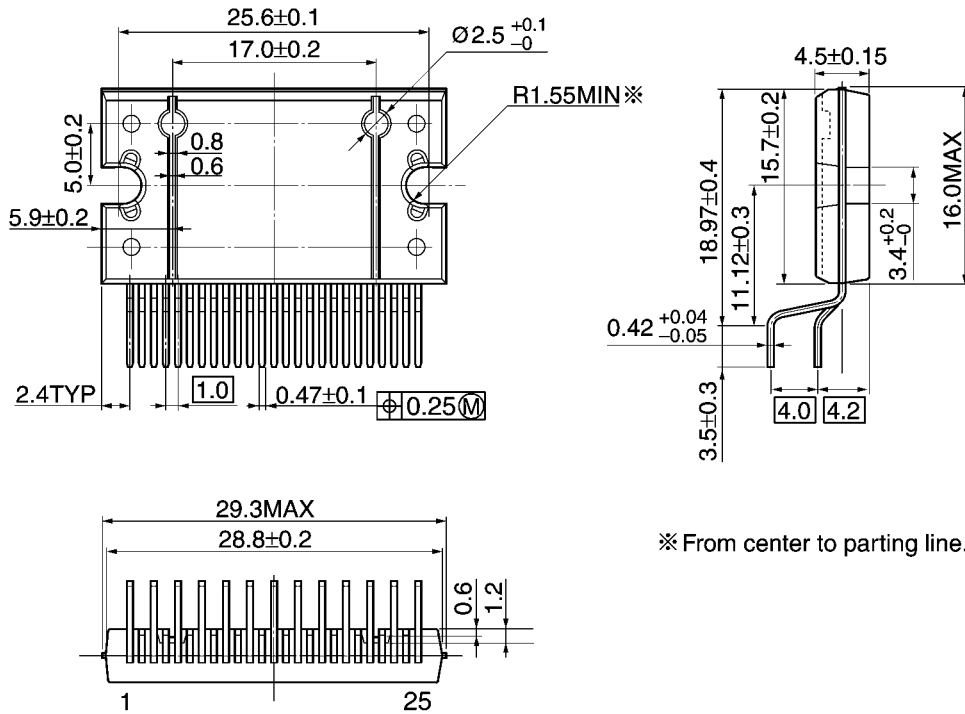

※ From center to parting line.

Weight: 7.7 g (typ.)

**RESTRICTIONS ON PRODUCT USE**

000707EBF

- TOSHIBA is continually working to improve the quality and reliability of its products. Nevertheless, semiconductor devices in general can malfunction or fail due to their inherent electrical sensitivity and vulnerability to physical stress. It is the responsibility of the buyer, when utilizing TOSHIBA products, to comply with the standards of safety in making a safe design for the entire system, and to avoid situations in which a malfunction or failure of such TOSHIBA products could cause loss of human life, bodily injury or damage to property.  
In developing your designs, please ensure that TOSHIBA products are used within specified operating ranges as set forth in the most recent TOSHIBA products specifications. Also, please keep in mind the precautions and conditions set forth in the "Handling Guide for Semiconductor Devices," or "TOSHIBA Semiconductor Reliability Handbook" etc..
- The TOSHIBA products listed in this document are intended for usage in general electronics applications (computer, personal equipment, office equipment, measuring equipment, industrial robotics, domestic appliances, etc.). These TOSHIBA products are neither intended nor warranted for usage in equipment that requires extraordinarily high quality and/or reliability or a malfunction or failure of which may cause loss of human life or bodily injury ("Unintended Usage"). Unintended Usage include atomic energy control instruments, airplane or spaceship instruments, transportation instruments, traffic signal instruments, combustion control instruments, medical instruments, all types of safety devices, etc.. Unintended Usage of TOSHIBA products listed in this document shall be made at the customer's own risk.
- This product generates heat during normal operation. However, substandard performance or malfunction may cause the product and its peripherals to reach abnormally high temperatures.  
The product is often the final stage (the external output stage) of a circuit. Substandard performance or malfunction of the destination device to which the circuit supplies output may cause damage to the circuit or to the product.
- The products described in this document are subject to the foreign exchange and foreign trade laws.
- The information contained herein is presented only as a guide for the applications of our products. No responsibility is assumed by TOSHIBA CORPORATION for any infringements of intellectual property or other rights of the third parties which may result from its use. No license is granted by implication or otherwise under any intellectual property or other rights of TOSHIBA CORPORATION or others.
- The information contained herein is subject to change without notice.