

TA8320F

LED DRIVER FOR CAMERA

TA8320F is Multi Chip IC incorporates 3 low saturation discrete transistors.

This IC is suitable for a camera use LED drive applications.

FEATURES

- Suitable for LED drive circuit.
- Small package sealed : SSOP10
- Low saturation voltage
- 3-channel sink type

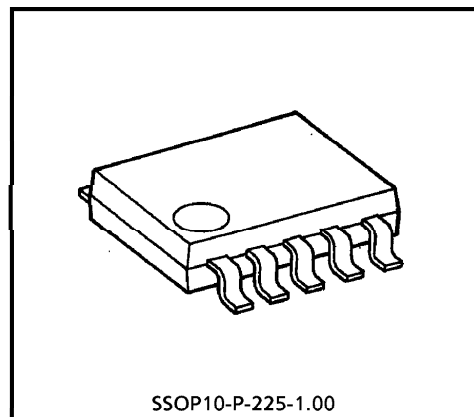

SSOP10-P-225-1.00
Weight : 0.10g (Typ.)

BLOCK DIAGRAM

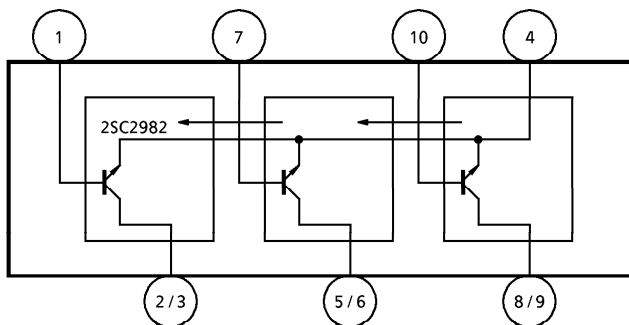

PIN CONNECTION

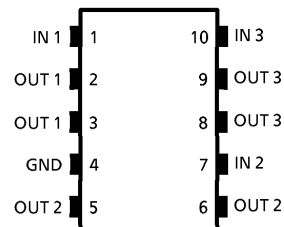

980910EBA2

● TOSHIBA is continually working to improve the quality and the reliability of its products. Nevertheless, semiconductor devices in general can malfunction or fail due to their inherent electrical sensitivity and vulnerability to physical stress. It is the responsibility of the buyer, when utilizing TOSHIBA products, to observe standards of safety, and to avoid situations in which a malfunction or failure of a TOSHIBA product could cause loss of human life, bodily injury or damage to property. In developing your designs, please ensure that TOSHIBA products are used within specified operating ranges as set forth in the most recent products specifications. Also, please keep in mind the precautions and conditions set forth in the TOSHIBA Semiconductor Reliability Handbook.

MAXIMUM RATINGS (Ta = 25°C)

CHARACTERISTIC	SYMBOL	RATING	UNIT
Supply Voltage	V _{CC}	10	V
Breakdown Voltage	V _{CB0}	10	V
	V _{CEO}	10	V
	V _{EBO}	6	V
Output Current	I _O	2	A
	I _{O (peak)}	(*) 4	
Base Current	I _B	0.4	A
	I _{B (peak)}	(*) 0.8	
Power Dissipation	P _D	590	mW
Junction Temperature	T _j	150	°C
Operating Temperature	T _{opr}	-40~85	°C
Storage Temperature	T _{stg}	-55~150	°C

(*) T = 10ms Max. and maximum duty is less than 30%

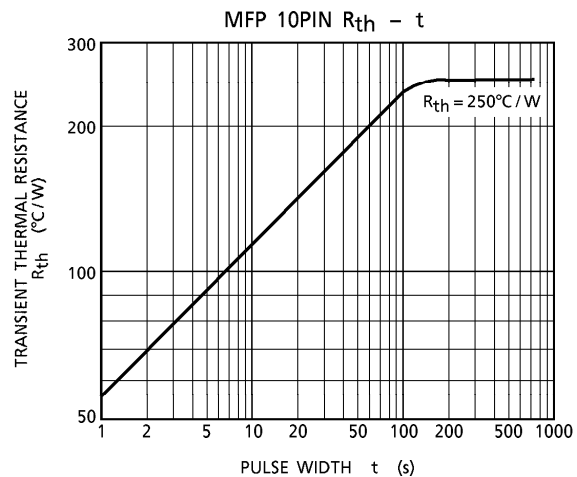
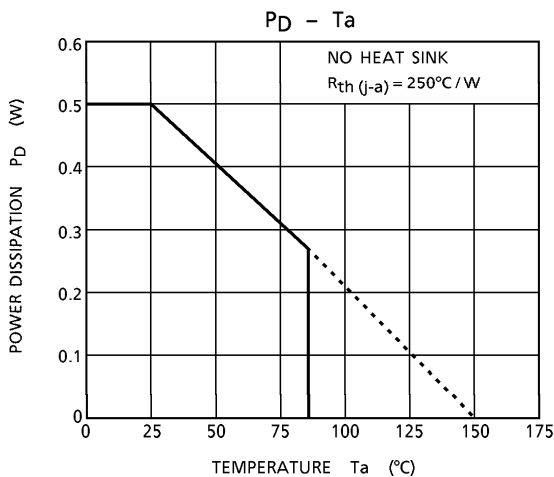

ELECTRICAL CHARACTERISTICS (Ta = 25°C)

CHARACTERISTIC	SYMBOL	TEST CIR-CUIT	TEST CONDITION	MIN.	TYP.	MAX.	UNIT
Current Gain	h _{FE (1)}	—	V _{CE} = 1V, I _C = 0.5A	160	—	600	
	h _{FE (2)}	—	V _{CE} = 1V, I _C = 2.0A	60	130	—	
Saturation Voltage	V _{CE (sat)}	—	I _C = 2A, I _B = 50mA	—	—	0.5	V
Transition Frequency	f _T	—	V _{CE} = 2V, I _C = 0.5A	—	150	—	MHz
Leakage Current	I _{OL}	—	V _{CC} = 10V	—	0	1.0	μA
Base-Emitter Forward Voltage	V _{BE}	—	V _{CE} = 1V, I _C = 2.0A	—	0.84	1.5	V

980910EBA2'

- The products described in this document are subject to the foreign exchange and foreign trade laws.
- The information contained herein is presented only as a guide for the applications of our products. No responsibility is assumed by TOSHIBA CORPORATION for any infringements of intellectual property or other rights of the third parties which may result from its use. No license is granted by implication or otherwise under any intellectual property or other rights of TOSHIBA CORPORATION or others.
- The information contained herein is subject to change without notice.

OUTLINE DRAWING
SSOP10-P-225-1.00

Unit : mm

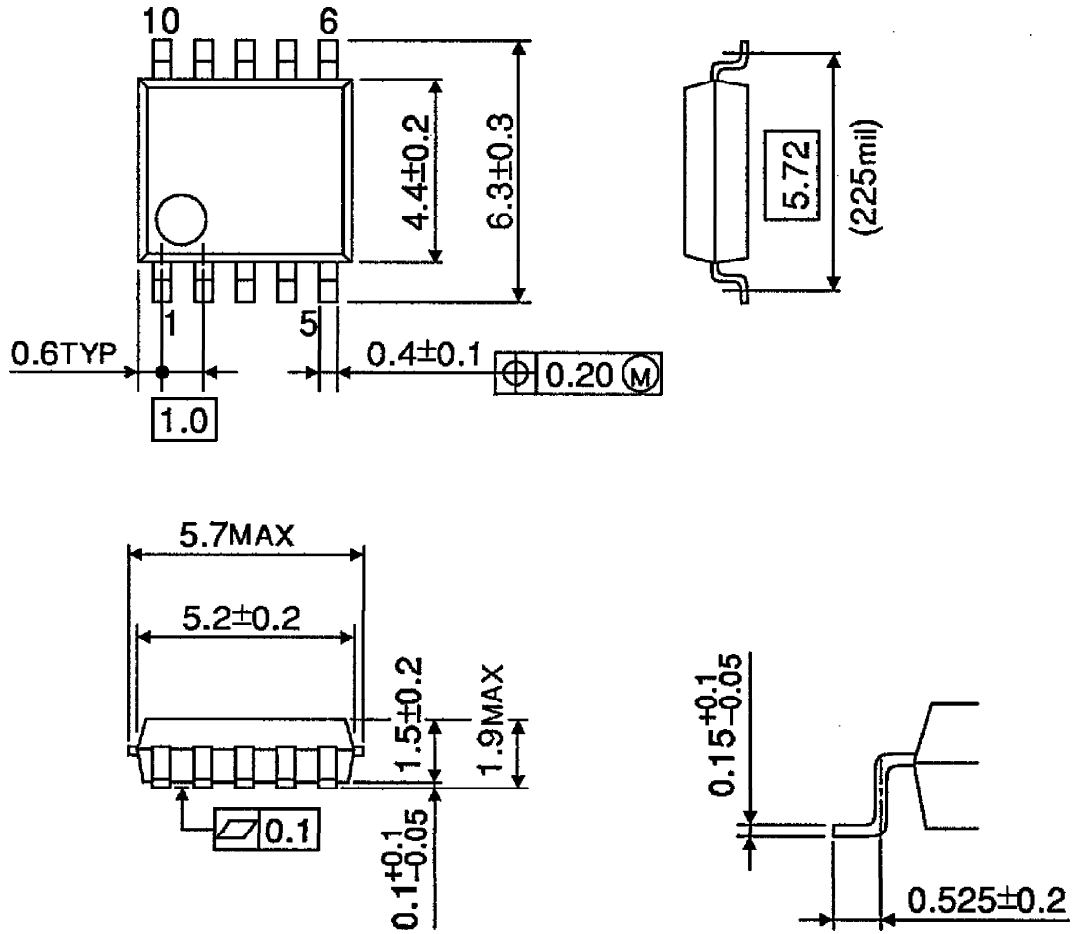

Weight : 0.10g (Typ.)