

TA8401F

FUNCTIONAL BRIDGE DRIVER

FEATURES

- Wide operating supply voltage range.
: V_{CC} (opr.) = 3.0~15 V
- Capsuled in flat package 16 pin.
- Forward and reverse rotation, short brake modes are Available by means of rotation control signals.
- High efficiency is obtained.
- Can be used as interface driver.

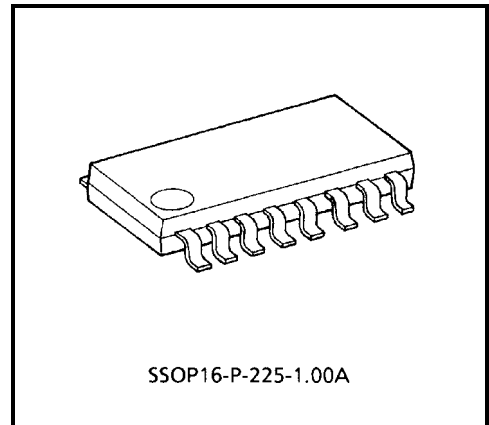

Weight: 0.14 g (Typ.)

BLOCK DIAGRAM

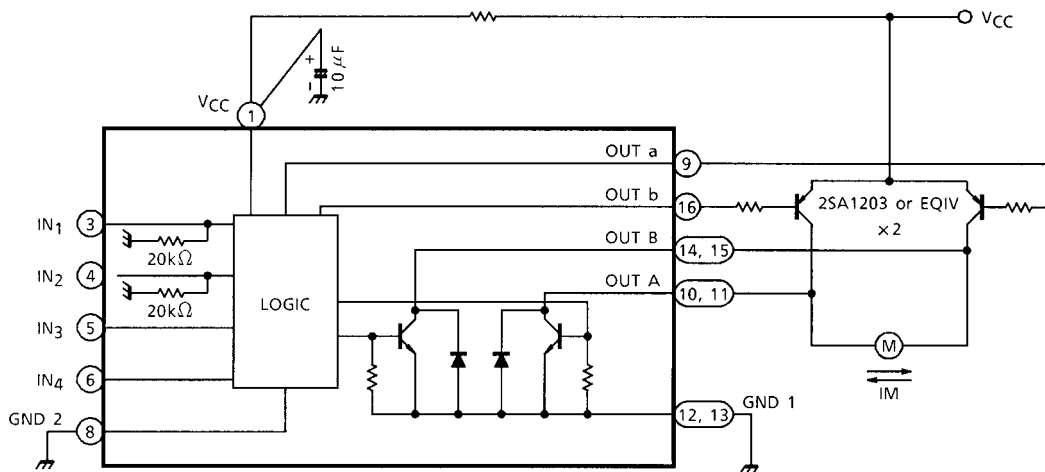

PIN FUNCTION

PIN No.	SYMBOL	FUNCTIONAL DESCRIPTION	
1	V _{CC}	Power supply voltage	
2	NC	Non Connection	
3	IN ₁	Signal input terminal	Truth table 1
4	IN ₂	Signal input terminal	
5	IN ₃	Signal input terminal	
6	IN ₄	Signal input terminal	
7	NC	No connection	
8	GND 2	Logic GND terminal	
9	OUT a	Output a	
10	OUT A	Output A	
11	OUT A		
12	GND 1	Power GND terminal	
13	GND 1		
14	OUT B	Output B	
15	OUT B		
16	OUT b	Output b	

FUNCTION

(1) Bridge driver (Truth table 1)

CONTROL	INPUT MODE				OUTPUT				OPERATING MODE	NOTE
	IN ₁	IN ₂	IN ₃	IN ₄	OUT A	OUT B	OUT a	OUT b		
2 Input Control	H	L	H	H	ON (-500 mA)	—	ON (-25 mA)	—	Forward Rotation	—
	L	H	H	H	—	ON (-500 mA)	—	ON (-25 mA)	Reverse Rotation	
	H	H	H	H	ON (-500 mA)	ON (-500 mA)	—	—	Brake	
	L	L	H	H	—	—	—	—	STOP	
1 Input Control	H	L	L	H	ON (-500 mA)	—	ON (-25 mA)	—	A ON	
	L	L	L	H	—	ON (-500 mA)	—	ON (-25 mA)	B ON	
	H / L	H	L	H	ON (-500 mA)	ON (-500 mA)	—	—	AB ON	
	—	—	—	L	—	—	—	—	INHIBIT	LOW 0.3 V (MAX)

(2) Interface driver application

If IN₃ and IN₄ connect to "HIGH" OUT A and OUT B can be used as a interface driver output for each inputs.

(Connect OUT a and OUT b to GND)

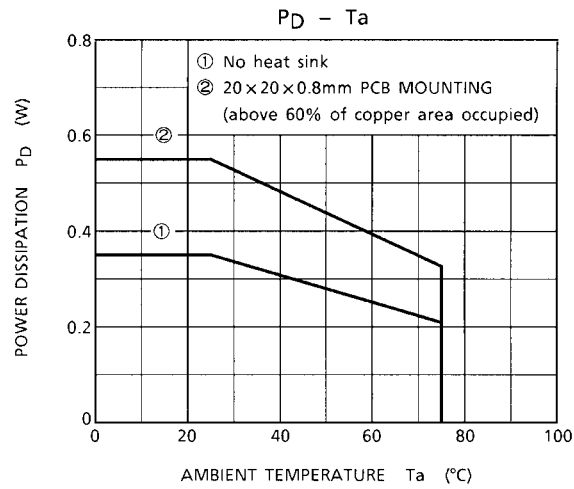

INPUT, OUTPUT CIRCUIT

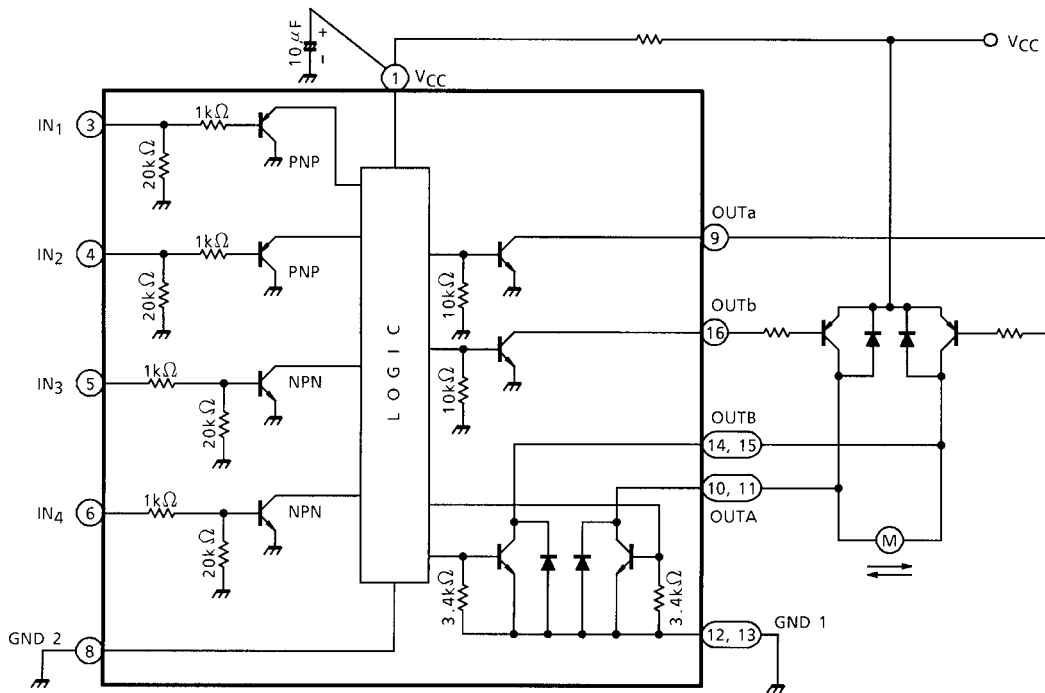

MAXIMUM RATINGS (Ta = 25°C)

CHARACTERISTIC	SYMBOL	RATING	UNIT
Peak Supply Voltage	V _{CC}	18	V
Output Current	I _O (AVE.)	0.5	A
Power Dissipation	P _D	350 (Note 1)	mW
		550 (Note 2)	
Operating Temperature	T _{opr}	-30~75	°C
Storage Temperature	T _{stg}	-55~150	°C

Note 1: No heat sink

Note 2: This rating is obtained by mounting on 20 × 20 × 0.8 mm PCB that occupied above 60% of copper area.

ELECTRICAL CHARACTERISTICS (Unless otherwise specified, Ta = 25°C, V_{CC} = 5 V)

CHARACTERISTIC		SYMBOL	TEST CIR-CUIT	TEST CONDITION	MIN	TYP.	MAX	UNIT
Supply Current		I _{CC1}	1	Output open CW / CCW mode	—	13	20	mA
		I _{CC2}	1	Output open stop mode	—	11	15	
		I _{CC3}	1	Output open brake mode	—	17	26	
		I _{CC4}	1	Inhibit (INPUT4 = "L")	—	2.4	7	
Output Saturation Voltage		V _{sat1}	2	I _{O1} = 500 mA, Lower side (Output A, B)	—	0.3	0.5	V
		V _{sat2}	2	I _{O2} = 25 mA, Upper side (Output a, b)	—	0.3	0.55	
Output TR Leakage Current		I _L	3	V _C = 15 V	—	—	50	μA
Input Voltage	"H" Level	V _{IN 1, 2} (H)	—	—	2.0	—	V _{CC}	V
	"L" Level	V _{IN 1, 2} (L)	—	—	—	—	0.8	
Input Current	"L" Level	I _{IN1, 2}	4	Input "L", V _{IN} = 0 V (Source current)	—	—	20	μA
Input Voltage	"H" Level	V _{IN 3, 4} (H)	—	—	1.0	—	V _{CC}	V
	"L" Level	V _{IN 3, 4} (L)	—	—	—	—	0.3	
Input Current	"H" Level	I _{IN3, 4}	4	Input "H" (Sink current) V _{IN} = 1 V	—	—	30	μA
Diode Forward Voltage		V _F	5	I _F = 0.5 A, V _{CC} = 0 V	—	1.3	—	V

TEST CIRCUIT

1. $I_{CC1, 2, 3, 4}$

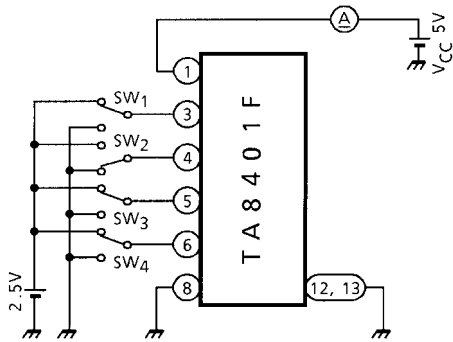

2. $V_{sat1, 2}$

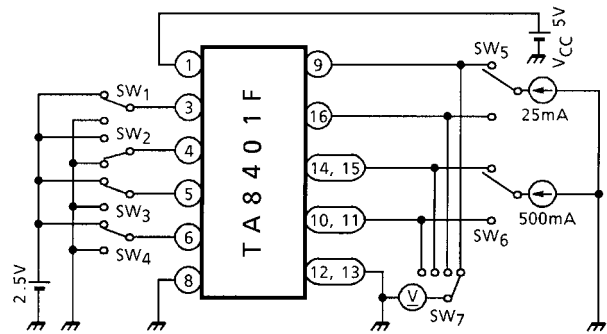

3. I_L

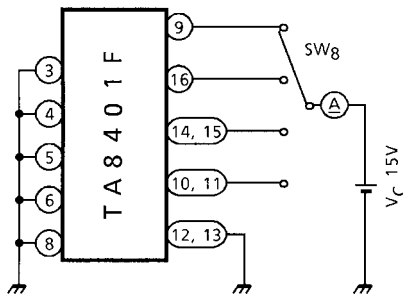

4. I_{IN}

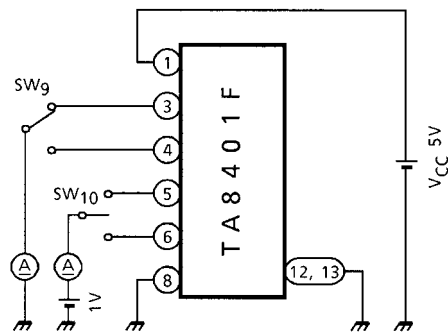

5. V_F

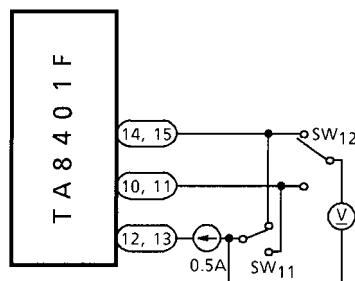

The functionable bridge driver, TA8401F, is an IC specifically developed to control rotation switching in brush motors. This IC has been carefully designed and strengthened to withstand counter-electromotive force or start up rush current, which are problems in driving brush motors.

However, as with other power ICs, application circuits must be designed not to apply surge voltage or excess current that exceeds the standard values. In addition, when designing PCBs, make sure the wiring pattern does not cause oscillation, which can result in equipment malfunction or destruction of the IC.

The following are notes on TA8401F use. These should be reflected at the design stage.

(1) Power supply voltage

To avoid the motor current affecting the TA8401F control-side power supply, we recommend you use two power supplies: an external transistor power supply, and a TA8401F control-side power supply. However, when using a single power supply, connect as in the diagram below.

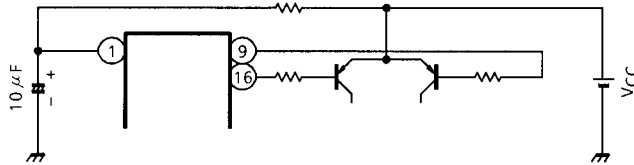

(2) Maximum voltage and current

The maximum supply voltage (pin (1)) for TA8401F is 18V. Operating supply voltage is in the range of 1.8~15 V. No voltage exceeding this range should be applied to pin (1).

The maximum current is 0.5 A (AVE.) or 1.5 A (PEAK). The circuit should be designed so that rush current at startup does not exceed peak current, and average current at steady operation does not exceed 0.5 A.

(3) External diodes

As the block diagram shows, TA8401F has internal diodes.

The lower two diodes, which are the IC's internal parasitic diodes, have a relatively large capacitance. However, when a motor with a large reactance such as a core motor is driven, the upper two diodes may be damaged by the motors counter-electromotive force. In such a case, connect external diodes in parallel. The lower diodes should not be subjected to high current. Therefore, in such cases as brake operation, external diodes should be connected.

(4) PCB design

The following points concern the TA8401F pattern design around the power supply line (pin (1)) and the pattern design of the GND (pin (8), pin (12) / (13)).

- a) Ensure that the bypass capacitor between pin (1), and GND does not share impedance with other lines.
- b) The GND line should not be shared by other circuits.
- c) The capacitance of the bypass capacitor should be as large as possible.

(5) Oscillation remedies

To prevent noise from sparks when using brush motors, a capacitor may be connected between both pins. When using TA8401F, the capacitor is connected between output pin (10) / (11), pin (14) / (15). This may cause oscillation.

Therefore, avoid connecting the capacitor where possible. If connection is necessary to overcome noise, connect resistors in series as shown in the technical data.

The values for the capacitor and resistors must be determined according to the motor.

Note: Utmost care is necessary in the design of the output line, V_{CC} and GND line since IC may be destroyed due to short-circuit between outputs, air contamination fault, or fault by improper grounding.

PACKAGE DIMENSIONS

SSOP16-P-225-1.00A

Unit: mm

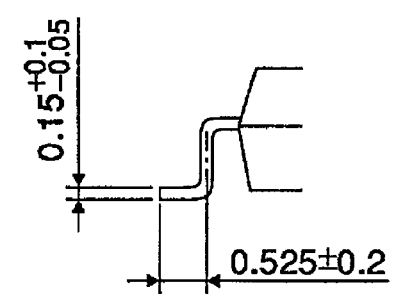
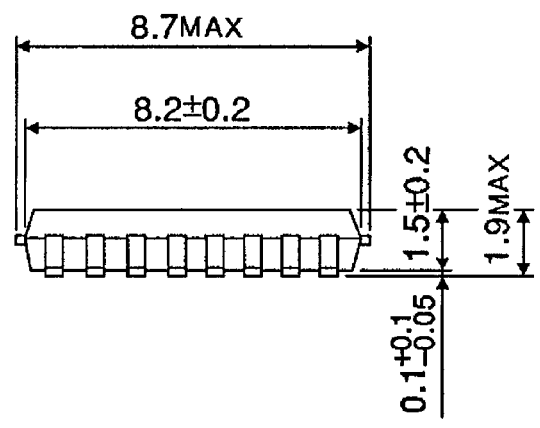
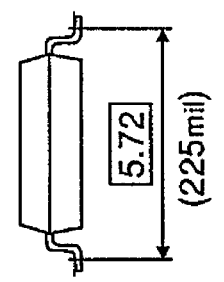
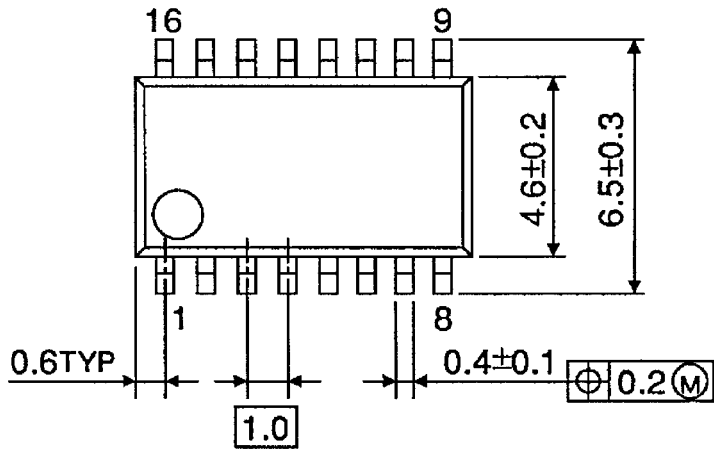

Weight: 0.14 g (Typ.)

RESTRICTIONS ON PRODUCT USE

000707EBA

- TOSHIBA is continually working to improve the quality and reliability of its products. Nevertheless, semiconductor devices in general can malfunction or fail due to their inherent electrical sensitivity and vulnerability to physical stress. It is the responsibility of the buyer, when utilizing TOSHIBA products, to comply with the standards of safety in making a safe design for the entire system, and to avoid situations in which a malfunction or failure of such TOSHIBA products could cause loss of human life, bodily injury or damage to property.
In developing your designs, please ensure that TOSHIBA products are used within specified operating ranges as set forth in the most recent TOSHIBA products specifications. Also, please keep in mind the precautions and conditions set forth in the "Handling Guide for Semiconductor Devices," or "TOSHIBA Semiconductor Reliability Handbook" etc..
- The TOSHIBA products listed in this document are intended for usage in general electronics applications (computer, personal equipment, office equipment, measuring equipment, industrial robotics, domestic appliances, etc.). These TOSHIBA products are neither intended nor warranted for usage in equipment that requires extraordinarily high quality and/or reliability or a malfunction or failure of which may cause loss of human life or bodily injury ("Unintended Usage"). Unintended Usage include atomic energy control instruments, airplane or spaceship instruments, transportation instruments, traffic signal instruments, combustion control instruments, medical instruments, all types of safety devices, etc.. Unintended Usage of TOSHIBA products listed in this document shall be made at the customer's own risk.
- The products described in this document are subject to the foreign exchange and foreign trade laws.
- The information contained herein is presented only as a guide for the applications of our products. No responsibility is assumed by TOSHIBA CORPORATION for any infringements of intellectual property or other rights of the third parties which may result from its use. No license is granted by implication or otherwise under any intellectual property or other rights of TOSHIBA CORPORATION or others.
- The information contained herein is subject to change without notice.