

TAS2563 6.1-W Boosted Class-D Audio Amplifier With Integrated DSP and IV Sense

1 Features

- Key Features
 - 11.5 V, 12-step Look-Ahead Class-H boost
 - Integrated DSP
 - Full Scale Ultrasonic Output to 40kHz
 - 2 PDM Microphone inputs
- Powerful Class-D Audio Amplifier :
 - 6.1 W 1% THD+N (4 Ω, 3.6 V)
 - 5 W 1% THD+N (8 Ω, 3.6 V)
 - 10 W 1% THD+N (4 Ω, 12 V)
- Protection Features:
 - Real-Time I/V-Sense Speaker Protection
 - Speaker Thermal & Over-Excursion Protection
 - Short and Open Load Protection
 - Thermal and Over-Current Protection
- Advanced Audio Processing
 - Dedicated Real-Time DSP with:
 - 10-Band Equalizer
 - 3-Band Dynamic EQ
 - Dynamic Range Compression
 - Psychoacoustic Bass
- Flexible Interfaces and Control :
 - I²S/TDM: 8 Channels of 32 Bit up to 96 KSPS
 - I²C: Selectable Addresses with Fast Mode+
 - Inter-Chp Communication Bus (DSBGA)
 - 8 kHz to 96 kHz Sample Rates
- Power Efficiency and Flexibility :
 - 83.5% Efficiency at 1W
 - <1uA HW Shutdown VBAT Current
 - Boost-Bypass Mode
- Power Supplies and Management
 - VBAT: 2.5 V to 5.5 V
 - VDD: 1.62 V to 1.95 V
 - PVDD: VBAT to 13 V (QFN)
 - PVDD: VBAT to 16 V (DSBGA)
 - IOVDD: 1.65 V to 3.6 V
 - VBAT Tracking Peak Voltage Limiter
 - Advanced Brown Out Prevention

2 Applications

- [Smart Phone, Tablets and Laptops](#)
- [Smart Speakers with Voice Assistance](#)
- [Bluetooth and Wireless Speakers](#)
- [Smart Home](#)
- [IP Camera](#)

3 Description

The TAS2563 is a digital input Class-D audio amplifier optimized for efficiently driving high peak power into small loudspeakers. The Class-D amplifier is capable of delivering 6.1 W of peak power into a 4 Ω load at battery voltage of 3.6 V using the integrated 11.5V Class-H boost, or 10W peak power into 4Ω load in boost bypass mode using external 12V supply.

An on-chip, low-latency DSP supports Texas Instruments SmartAmp speaker protection algorithms. The integrated current and voltage sense provide for real-time monitoring of the loudspeakers, which permits pushing peak sound pressure levels (SPL) while keeping speakers from being damaged.

The integrated look-ahead Class-H boost dynamically adjusts boost voltage during playback, increasing efficiency and saving battery life in battery-powered systems. For regulated wall-powered systems, TAS2563 also features a boost bypass mode, supporting supply voltages of up to 16V for even higher output power.

Two PDM microphone inputs simplify audio signal chain for two-way audio systems, interfacing digital microphones with the host processor. A battery tracking peak voltage limiter with brown-out protection prevents systems shutdowns by optimizing amplifier headroom over the entire charge cycle.

Device Information⁽¹⁾

PART NUMBER	PACKAGE	BODY SIZE (NOM)
TAS2563	DSBGA	2.5 mm × 3 mm
TAS2563	QFN	4.5 mm x 4 mm

- (1) For all available packages, see the orderable addendum at the end of the data sheet.

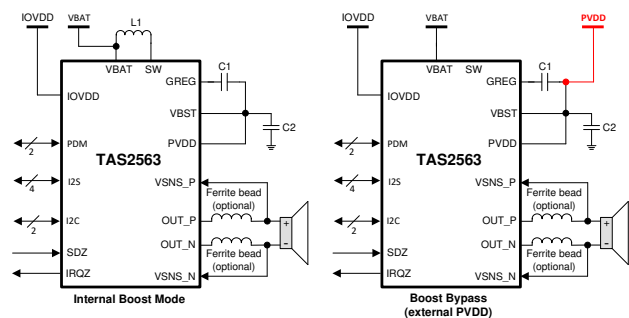

Simplified Schematic

Table of Contents

1 Features	1	8.3 Feature Description.....	30
2 Applications	1	8.4 Device Functional Modes.....	39
3 Description	1	8.5 Register Maps.....	64
4 Revision History	2	9 Application and Implementation	95
5 Pin Configuration and Functions	3	9.1 Application Information.....	95
Pin Functions.....	4	9.2 Typical Application.....	95
6 Specifications	6	10 Power Supply Recommendations	99
6.1 Absolute Maximum Ratings	6	10.1 Power Supplies.....	99
6.2 ESD Ratings	6	10.2 Power Supply Sequencing.....	99
6.3 Recommended Operating Conditions	6	11 Layout	100
6.4 Thermal Information	7	11.1 Layout Guidelines.....	100
6.5 Electrical Characteristics	7	11.2 Layout Example.....	101
6.6 I ² C Timing Requirements	14	12 Device and Documentation Support	105
6.7 SPI Timing Requirements	15	12.1 Documentation Support.....	105
6.8 PDM Port Timing Requirements	15	12.2 Receiving Notification of Documentation Updates.....	105
6.9 TDM Port Timing Requirements	15	12.3 Support Resources.....	105
6.10 Timing Diagrams.....	16	12.4 Trademarks.....	105
6.11 Typical Characteristics.....	18	12.5 Electrostatic Discharge Caution.....	105
7 Parameter Measurement Information	28	12.6 Glossary.....	105
8 Detailed Description	29	13 Mechanical, Packaging, and Orderable Information	105
8.1 Overview.....	29		
8.2 Functional Block Diagram.....	29		

4 Revision History

NOTE: Page numbers for previous revisions may differ from page numbers in the current version.

Changes from Revision B (December 2020) to Revision C (March 2021)	Page
• Added QFN THDN Isense.....	7
• Removed Idle Channel QFN.....	7
• Added Current Consumption with Speaker Protection ON.....	7
• Updated DNR QFN Package.....	7
• Updated DNR for Isense and Vsense.....	7
• Removed Group Delay.....	7
• Updated Captive Load for fast I2C.....	14
• Merged Efficiency vs Output Power for both packages.....	18
• Added AVDD and VBAT Idle Current QFN Package.....	18
• Merged Vsense characteristics for both packages.....	18

Changes from Revision A (August 2019) to Revision B (December 2020)	Page
• Added RPP mechanical data	1
• Changed device status to Mixed Production.....	1
• Added QFN package as Advanced Information	1

Changes from Revision * (April 2019) to Revision A (August 2019)	Page
• Changed TAS2562 from Advance Information to Production Data	1

5 Pin Configuration and Functions

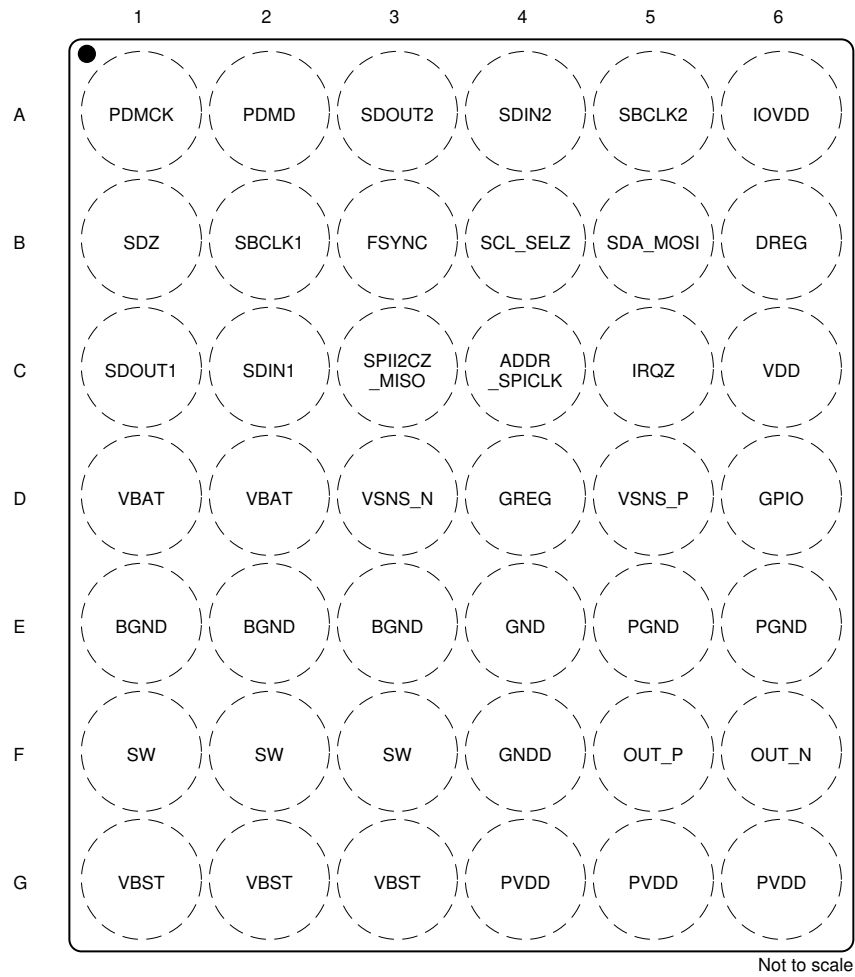

Figure 5-1. YBG Package 42-Ball DSBGA Top View

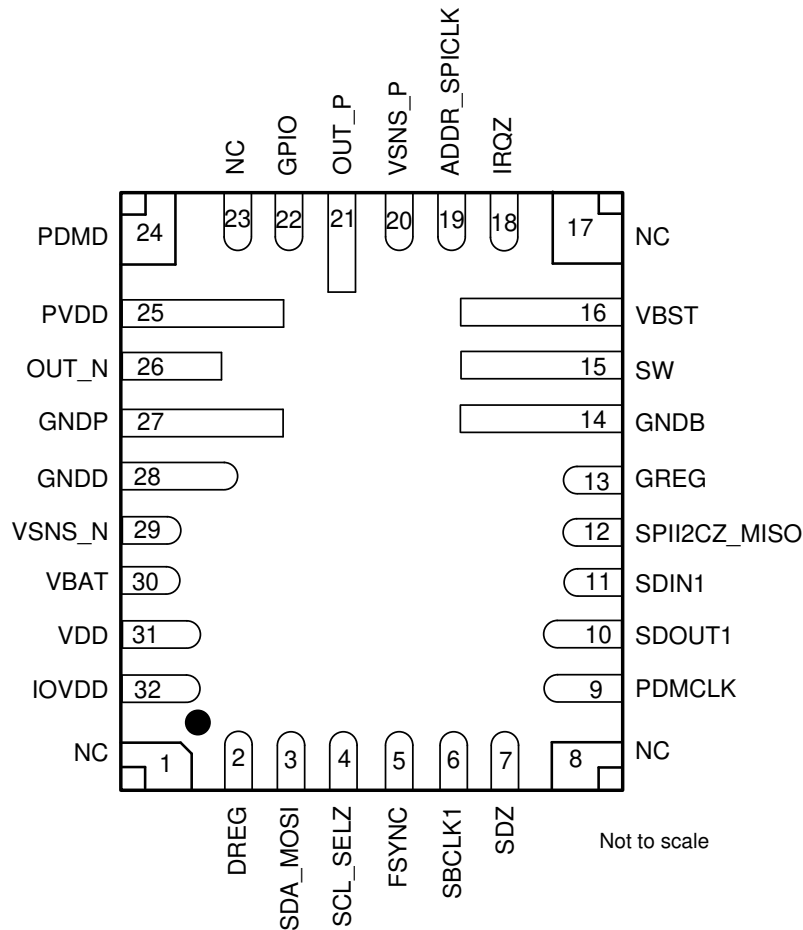

Figure 5-2. RPP Package 32-pin QFN Top View

Pin Functions

NAME	PIN		TYPE	DESCRIPTION
	DSBGA NO.	QFN NO.		
ADDR_SPI CLK	C4	19	I	I2C Mode - Address selection pin See General I2C operation. SPI Mode - SPI clock
DREG	B6	2	P	Digital core voltage regulator output. Bypass to GND with a cap. Do not connect to external load.
FSYNC	B3	5	I	I2S word clock or TDM frame sync for ASI1 and ASI2 channels.
GNDB	E1, E2, E3	14	P	Boost ground. Connect to PCB GND plane.
GNDD	F4	28	P	Digital ground. Connect to PCB GND plane.
GND	E4	N/A	P	Analog ground. Connect to PCB GND plane.
GNDP	E5,E6	27	P	Power stage ground. Connect to PCB GND plane.
GPIO	D6	22	IO	General purpose input-ouput or MCLK base on register configuration.
GREG	D4	13	P	High-side gate CP regulator output. Do not connect to external load.
IOVDD	A6	32	P	3.3-V/1.8-V IOVDD Supply
IRQZ	C5	18	O	Open drain, active low interrupt pin. Pull up to IOVDD with resistor if optional internal pull up is not used.
OUT_N	F6	26	O	Class-D negative output for receiver channel.
OUT_P	F5	21	O	Class-D positive output for receiver channel.
PDMCLK	A1	9	IO	PDM clock.

PIN			TYPE	DESCRIPTION
NAME	DSBGA NO.	QFN NO.		
PDMD	A2	24	IO	PDM data.
PVDD	G4, G5, G6	25	P	Power stage supply.
SBCLK1	B2	6	I	ASI1 channel I2S/TDM serial bit clock.
SBCLK2	A5		I	ASI2 channel I2S/TDM serial bit clock.
SDA_MOSI	B5	3	IO	I2C Mode: I ² C Data Pin. Pull up to IOVDD with a resistor. SPI Mode: Serial data input pin.
SDIN1	C2	11	I	ASI1 channel I2S/TDM serial data input.
SDIN2	A4		I	ASI2 channel I2S/TDM serial data input.
SDOUT1	C1	10	IO	ASI1 channel I2S/TDM serial data output.
SDOUT2	A3		IO	ASI2 channel I2S/TDM serial data output.
SDZ	B1	7	I	Active low hardware shutdown.
SCL_SELZ	B4	4	IO	I2C Mode: I2C clock pin. Pull up to IOVDD with a resistor. SPI Mode: active low chip select.
SPII2CZ_MISO	C3	12	IO	Pin is queried on power-up. Short to GND for I2C Mode. Pull to IOVDD with resistor for SPI mode. SPI serial data output pin.
SW	F1, F2, F3	15	P	Boost converter switch input.
VBAT	D1, D2	30	P	Battery power supply input. Connect to 2.7 V to 5.5 V supply and decouple with a cap.
VBST	G1, G2, G3	16	P	Boost converter output. Do not connect to external load.
VDD	C6	31	P	Analog, digital, and IO power supply. Connect to 1.8 V supply and decouple to GND with cap.
VSNS_N	D3	29	I	Voltage sense negative input. Connect to Class-D OUT_N output after Ferrite bead filter.
VSNS_P	D5	20	I	Voltage sense positive input. Connect to Class-D OUT_P output after Ferrite bead filter.
NC		1, 8, 17		No Connect.

6 Specifications

6.1 Absolute Maximum Ratings

over operating free-air temperature range (unless otherwise noted) ⁽¹⁾

		MIN	MAX	UNIT
IO Supply IOVDD	IOVDD	-0.3	3.9	V
Analog Voltage	VDD	-0.3	2	V
Battery Supply Voltage	VBAT	-0.3	6	V
Boost Pin	VBST	-0.3	18.5	V
Power Supply Voltage	PVDD ⁽³⁾	-0.3	18.5	V
Switching Pin	SW	-0.7	16	V
High Side Regulator Pin	GREG	-0.3	PVDD+6	V
Digital Regular Pin	DREG	-0.3	1.65	V
Input voltage ⁽²⁾	Digital IOs referenced to VDD supply	-0.3	VDD+0.3	V
Operating free-air temperature, T _A		-40	85	°C
Operating junction temperature, T _J		-40	150	°C
Storage temperature, T _{stg}		-65	150	°C

(1) Stresses beyond those listed under *Absolute Maximum Ratings* can cause permanent damage to the device. These are stress ratings only, which do not imply functional operation of the device at these or any other conditions beyond those indicated under *Recommended Operating Procedures*. Exposure to absolute-maximum-rated conditions for extended periods can affect device reliability.

(2) All digital inputs and IOs are failsafe.

(3) PVDD can handle 19V transients for less than 10ns

6.2 ESD Ratings

			VALUE	UNIT
V _(ESD)	Electrostatic discharge	Human-body model (HBM), per ANSI/ESDA/JEDEC JS-001 OUT_N / OUT_P / VSNS_N / VSNS_P Pins ⁽¹⁾	±3000	V
		Human-body model (HBM), per ANSI/ESDA/JEDEC JS-001 ⁽¹⁾	±2000	V
		Charged-device model (CDM), per JEDEC specification JESD22-C101 ⁽²⁾	±500	

(1) JEDEC document JEP155 states that 500-V HBM allows safe manufacturing with a standard ESD control process.

(2) JEDEC document JEP157 states that 250-V CDM allows safe manufacturing with a standard ESD control process.

6.3 Recommended Operating Conditions

over operating free-air temperature range (unless otherwise noted)

		MIN	NOM	MAX	UNIT
IOVDD	IO Supply Voltage 1.8V	1.62	1.8	1.98	V
IOVDD	IO Supply Voltage 3.3V	3	3.3	3.6	V
VBAT	Supply voltage	2.5	3.6	5.5	V
VDD	Supply voltage	1.62	1.8	1.95	V
PVDD _{DSBGA} (VBST)	Supply voltage - external boost mode (DSBGA package)	VBAT		16	V
PVDD _{QFN} (VBST)	Supply voltage - external boost mode (QFN package)	VBAT		13	V
V _{IH}	High-level digital input voltage	0.7 x IOVDD			V
V _{IL}	Low-level digital input voltage	0			V
R _{SPK}	Minimum speaker impedance	3.2			Ω
L _{SPK}	Minimum speaker inductance	10			μH

6.4 Thermal Information

THERMAL METRIC ⁽¹⁾		TAS2563		UNIT
		RPP (QFN)	YBG (WCSP)	
		32 PINS	42 PINS	
R _{θJA}	Junction-to-ambient thermal resistance	43.7	55.3	°C/W
R _{θJC(top)}	Junction-to-case (top) thermal resistance	20.3	0.3	°C/W
R _{θJB}	Junction-to-board thermal resistance	10.5	11.6	°C/W
ψ _{JT}	Junction-to-top characterization parameter	0.5	0.2	°C/W
ψ _{JB}	Junction-to-board characterization parameter	10.5	11.6	°C/W
R _{θJC(bot)}	Junction-to-case (bottom) thermal resistance	N/A	N/A	°C/W

(1) For more information about traditional and new thermal metrics, see the *Semiconductor and IC Package Thermal Metrics* application report, [SPRA953](#).

6.5 Electrical Characteristics

T_A = 25 °C, V_{BAT} = 3.6 V, (External PVDD = 12 V), VDD = 1.8 V, R_L = 8Ω + 33 μH, f_{in} = 1 kHz, SSM, f_s = 48 kHz, Gain = 16 dBV (External PVDD Gain=18 dBV), SDZ = 1, Thermal Foldback Disabled, Measured filter free with an Audio Precision with a 22 Hz to 20 kHz un-weighted bandwidth (unless otherwise noted).

PARAMETER	TEST CONDITIONS	MIN	TYP	MAX	UNIT
DIGITAL INPUT and OUTPUT					
V _{IH}	High-level digital input logic voltage threshold (max current limit = 30 mA)	All digital pins except SDA_MOSI and SCL_SELZ	0.65 × IOVDD		V
V _{IL}	Low-level digital input logic voltage threshold (max current limit = 30 mA)	All digital pins except SDA_MOSI and SCL_SELZ		0.35 × IOVDD	V
V _{IH(I2C)}	High-level digital input logic voltage threshold (max current limit = 30 mA)	SDA_MOSI and SCL_SELZ	0.7 × IOVDD		V
V _{IL(I2C)}	Low-level digital input logic voltage threshold (max current limit = 30 mA)	SDA_MOSI and SCL_SELZ		0.3 × IOVDD	V
V _{OH}	High-level digital output voltage (max current limit = 30 mA)	All digital pins except SDA_MOSI, SCL_SELZ and IRQZ; I _{OH} = 2 mA.	IOVDD – 0.45 V		V
V _{OL}	Low-level digital output voltage (max current limit = 30 mA)	All digital pins except SDA_MOSI, SCL_SELZ and IRQZ; I _{OL} = –2 mA.		0.45	V
V _{OL(I2C)}	Low-level digital output voltage (max current limit = 30 mA)	SDA and SCL; I _{OL(I2C)} = –2 mA.		0.2 × IOVDD	V
V _{OL(IRQZ)}	Low-level digital output voltage for IRQZ open drain Output (max current limit = 30 mA)	IRQZ; I _{OL(IRQZ)} = –2 mA.		0.45	V
I _{IH}	Input logic-high leakage for digital inputs	All digital pins; Input = VDD.	–5	0.1	5 μA
I _{IL}	Input logic-low leakage for digital inputs	All digital pins; Input = GND.	–5	0.1	5 μA
C _{IN}	Input capacitance for digital inputs	All digital pins		8	pF
R _{PD}	Pull down resistance for digital input/IO pins when asserted on	SDOUT, SDIN, FSYNC, SBCLK		50	kΩ
AMPLIFIER PERFORMANCE - Internal Boost					
	Output Voltage for Full-scale digital Input	Measured at -6 dB FS input		6.32	V _{rms}

TAS2563

SLASET3C – APRIL 2019 – REVISED MARCH 2021

$T_A = 25\text{ }^\circ\text{C}$, $V_{BAT} = 3.6\text{ V}$, (External PVDD = 12 V), $V_{DD} = 1.8\text{ V}$, $R_L = 8\ \Omega + 33\ \mu\text{H}$, $f_{in} = 1\text{ kHz}$, SSM, $f_s = 48\text{ kHz}$, Gain = 16 dBV (External PVDD Gain=18 dBV), SDZ = 1, Thermal Foldback Disabled, Measured filter free with an Audio Precision with a 22 Hz to 20 kHz un-weighted bandwidth (unless otherwise noted).

PARAMETER		TEST CONDITIONS	MIN	TYP	MAX	UNIT
P _{OUT}	Maximum Continuous Output Power	R _L = 32Ω + 33 μH, THD+N = 0.03 %, f _{in} = 1 kHz		1.25		W
		R _L = 8 Ω + 33 μH, THD+N = 0.03 %, f _{in} = 1 kHz		5		W
		R _L = 4 Ω + 33 μH, THD+N = 1 %, f _{in} = 1 kHz		6.1		W
System efficiency at P _{OUT} = 1 W		R _L = 8 Ω + 33 μH, f _{in} = 1 kHz, DSBGA package		82		%
		R _L = 8 Ω + 33 μH, f _{in} = 1 kHz, QFN package		81.3		%
		R _L = 4 Ω + 33 μH, f _{in} = 1 kHz		78.5		%
		R _L = 8 Ω + 33 μH, f _{in} = 1 kHz, V _{BAT} = 4.2 V, DSBGA package		82.5		%
		R _L = 8 Ω + 33 μH, f _{in} = 1 kHz, V _{BAT} = 4.2 V, QFN package		81.7		%
		R _L = 4 Ω + 33 μH, f _{in} = 1 kHz, V _{BAT} = 4.2 V		84.2		%
System efficiency at P _{OUT} = 0.5 W		R _L = 8 Ω + 33 μH, f _{in} = 1 kHz, DSBGA package		76.6		%
		R _L = 8 Ω + 33 μH, f _{in} = 1 kHz, QFN		75.8		%
		R _L = 4 Ω + 33 μH, f _{in} = 1 kHz		81.1		%
		R _L = 8 Ω + 33 μH, f _{in} = 1 kHz, V _{BAT} = 4.2 V		84.2		%
		R _L = 4 Ω + 33 μH, f _{in} = 1 kHz, V _{BAT} = 4.2 V		81.6		%
THD+N	Total harmonic distortion + noise	P _{OUT} = 0.25 W, R _L = 32Ω + 33 μH, f _{in} = 1 kHz		0.01		%
		P _{OUT} = 1 W, R _L = 8 Ω + 33 μH, f _{in} = 1 kHz		0.01		%
		P _{OUT} = 1 W, R _L = 4 Ω + 33 μH, f _{in} = 1 kHz		0.01		%
V _N	Idle channel noise	A-Weighted, 20 Hz - 20 kHz, DAC Modulator Running		14.8		μV
F _{PWM}	Class-D PWM switching frequency	Average frequency in Spread Spectrum Mode, CLASSD_SYNC=0		384		kHz
		Fixed Frequency Mode, CLASSD_SYNC=0		384		kHz
		Fixed Frequency Mode, CLASSD_SYNC=1, f _s = 44.1, 88.2, 174.6 kHz		352.8		kHz
		Fixed Frequency Mode, CLASSD_SYNC=1, f _s = 48, 96, 192 kHz		384		kHz
V _{OS}	Output offset voltage		-1		1	mV
DNR	Dynamic range, DSBGA Package	A-Weighted, -60 dBFS Method		109		dB
DNR	Dynamic range, QFN Package	A-Weighted, -60 dBFS Method		105		dB
SNR	Signal to noise ratio	A-Weighted, Referenced to 1 % THD+N Output Level		112.5		dB
K _{CP}	Click and pop performance	Into and out of Mute, Shutdown, Power Up, Power Down and audio clocks starting and stopping. Measured with APx Plugin.		3.4		mV

$T_A = 25\text{ }^\circ\text{C}$, $V_{BAT} = 3.6\text{ V}$, (External PVDD = 12 V), $V_{DD} = 1.8\text{ V}$, $R_L = 8\ \Omega + 33\ \mu\text{H}$, $f_{in} = 1\text{ kHz}$, SSM, $f_s = 48\text{ kHz}$, Gain = 16 dBV (External PVDD Gain=18 dBV), SDZ = 1, Thermal Foldback Disabled, Measured filter free with an Audio Precision with a 22 Hz to 20 kHz un-weighted bandwidth (unless otherwise noted).

PARAMETER		TEST CONDITIONS	MIN	TYP	MAX	UNIT
	Programmable output level range		8		18	dBV
	Programmable output level step size			0.5		dB
$A_{V_{ERROR}}$	Amplifier gain error	$P_{OUT} = 1\text{ W}$		± 0.1		dB
	Mute attenuation	Device in Shutdown or Muted in Normal Operation		110		dB
	VBAT power-supply rejection ratio	$V_{BAT} = 3.6\text{ V} + 200\text{ mV}_{pp}$, $f_{ripple} = 217\text{ Hz}$		108		dB
		$V_{BAT} = 3.6\text{ V} + 200\text{ mV}_{pp}$, $f_{ripple} = 20\text{ kHz}$		90		dB
	AVDD power-supply rejection ratio	$V_{DD} = 1.8\text{ V} + 200\text{ mV}_{pp}$, $f_{ripple} = 217\text{ Hz}$		98		dB
		$V_{DD} = 1.8\text{ V} + 200\text{ mV}_{pp}$, $f_{ripple} = 20\text{ kHz}$		93		dB
	Turn on time from release of SW shutdown	No Volume Ramping		1.8		ms
		Volume Ramping		4.5		ms
	Turn off time from assertion of SW shutdown to amp Hi-Z	No Volume Ramping		1.5		ms
		Volume Ramping		12.5		ms
AMPLIFIER PERFORMANCE - External PVDD						
	Output Voltage for Full-scale digital Input	Measured at -6 dB FS input		7.94		V _{rms}
P_{OUT}	Maximum Continuous Output Power	$R_L = 32\ \Omega + 33\ \mu\text{H}$, THD+N = 1 %, $f_{in} = 1\text{ kHz}$		1.3		W
		$R_L = 8\ \Omega + 33\ \mu\text{H}$, THD+N = 1 %, $f_{in} = 1\text{ kHz}$		5.2		W
		$R_L = 4\ \Omega + 33\ \mu\text{H}$, THD+N = 1 %, $f_{in} = 1\text{ kHz}$		10.4		W
		$R_L = 32\ \Omega + 33\ \mu\text{H}$, THD+N = 10 %, $f_{in} = 1\text{ kHz}$		1.6		W
		$R_L = 8\ \Omega + 33\ \mu\text{H}$, THD+N = 10 %, $f_{in} = 1\text{ kHz}$		6.3		W
		$R_L = 4\ \Omega + 33\ \mu\text{H}$, THD+N = 10 %, $f_{in} = 1\text{ kHz}$		12.6		W
	System efficiency at $P_{OUT} = 1\text{ W}$	$R_L = 8\ \Omega + 33\ \mu\text{H}$, $f_{in} = 1\text{ kHz}$		83.8		%
		$R_L = 4\ \Omega + 33\ \mu\text{H}$, $f_{in} = 1\text{ kHz}$		80		%
		$R_L = 8\ \Omega + 33\ \mu\text{H}$, $f_{in} = 1\text{ kHz}$, External PVDD = 8.4 V		85.9		%
		$R_L = 4\ \Omega + 33\ \mu\text{H}$, $f_{in} = 1\text{ kHz}$, External PVDD = 8.4 V		81.8		%
THD+N	Total harmonic distortion + noise	$P_{OUT} = 0.25\text{ W}$, $R_L = 32\ \Omega + 33\ \mu\text{H}$, $f_{in} = 1\text{ kHz}$		0.01		%
		$P_{OUT} = 1\text{ W}$, $R_L = 8\ \Omega + 33\ \mu\text{H}$, $f_{in} = 1\text{ kHz}$		0.01		%
		$P_{OUT} = 1\text{ W}$, $R_L = 4\ \Omega + 33\ \mu\text{H}$, $f_{in} = 1\text{ kHz}$		0.02		%
V_N	Idle channel noise	A-Weighted, 20 Hz - 20 kHz, DAC Modulator Running		21.3		μV

TAS2563

SLASET3C – APRIL 2019 – REVISED MARCH 2021

$T_A = 25\text{ }^\circ\text{C}$, $V_{BAT} = 3.6\text{ V}$, (External PVDD = 12 V), $V_{DD} = 1.8\text{ V}$, $R_L = 8\Omega + 33\text{ }\mu\text{H}$, $f_{in} = 1\text{ kHz}$, SSM, $f_s = 48\text{ kHz}$, Gain = 16 dBV (External PVDD Gain=18 dBV), SDZ = 1, Thermal Foldback Disabled, Measured filter free with an Audio Precision with a 22 Hz to 20 kHz un-weighted bandwidth (unless otherwise noted).

PARAMETER		TEST CONDITIONS	MIN	TYP	MAX	UNIT
F _{PWM}	Class-D PWM switching frequency	Average frequency in Spread Spectrum Mode, CLASSD_SYNC=0		384		kHz
		Fixed Frequency Mode, CLASSD_SYNC=0		384		kHz
		Fixed Frequency Mode, CLASSD_SYNC=1, $f_s = 44.1, 88.2, 174.6\text{ kHz}$		352.8		kHz
		Fixed Frequency Mode, CLASSD_SYNC=1, $f_s = 48, 96, 192\text{ kHz}$		384		kHz
V _{OS}	Output offset voltage		-1		1	mV
DNR	Dynamic range	A-Weighted, -60 dBFS Method		109		dB
SNR	Signal to noise ratio	A-Weighted, Referenced to 1 % THD+N Output Level		109		dB
K _{CP}	Click and pop performance	Into and out of Mute, Shutdown, Power Up, Power Down and audio clocks starting and stopping. Measured with APx Plugin.		3		mV
	Programmable output level range		8		18	dBV
	Programmable output level step size			0.5		dB
AV _{ERROR}	Amplifier gain error	P _{OUT} = 1 W		±0.1		dB
	Mute attenuation	Device in Shutdown or Muted in Normal Operation		110		dB
	VBAT power-supply rejection ratio	V _{BAT} = 3.6 V + 200 mV _{pp} , $f_{ripple} = 217\text{ Hz}$		110		dB
		V _{BAT} = 3.6 V + 200 mV _{pp} , $f_{ripple} = 20\text{ kHz}$		90		dB
	PVDD power-supply rejection ratio	PVDD = 12 V + 200 mV _{pp} , $f_{ripple} = 217\text{ Hz}$		105		dB
		PVDD = 12 V + 200 mV _{pp} , $f_{ripple} = 20\text{ kHz}$		90		dB
	AVDD power-supply rejection ratio	V _{DD} = 1.8 V + 200 mV _{pp} , $f_{ripple} = 217\text{ Hz}$		86		dB
		V _{DD} = 1.8 V + 200 mV _{pp} , $f_{ripple} = 20\text{ kHz}$		73		dB
	Turn on time from release of SW shutdown	No Volume Ramping		2		ms
		Volume Ramping		4.8		ms
	Turn off time from assertion of SW shutdown to amp Hi-Z	No Volume Ramping		1.1		ms
		Volume Ramping		12.6		ms
BOOST CONVERTER						
	Startup inrush current limit	default setting		1.5		A
	Startup inrush limit time	default setting		0.45		ms
	Switching Frequency	PFM mode		50		kHz
		Current Control Mode		4		MHz
	Inductor Peak Current Limit	default setting		4		A
DIE TEMPERATURE SENSOR						
	Resolution			8		bits
	Die temperature measurement range		-40		150	°C

$T_A = 25\text{ }^\circ\text{C}$, $V_{BAT} = 3.6\text{ V}$, (External PVDD = 12 V), $V_{DD} = 1.8\text{ V}$, $R_L = 8\Omega + 33\text{ }\mu\text{H}$, $f_{in} = 1\text{ kHz}$, SSM, $f_s = 48\text{ kHz}$, Gain = 16 dBV (External PVDD Gain=18 dBV), SDZ = 1, Thermal Foldback Disabled, Measured filter free with an Audio Precision with a 22 Hz to 20 kHz un-weighted bandwidth (unless otherwise noted).

PARAMETER		TEST CONDITIONS	MIN	TYP	MAX	UNIT
	Die temperature resolution			0.75		$^\circ\text{C}$
	Die temperature accuracy			± 5		$^\circ\text{C}$
VOLTAGE MONITOR						
	Resolution			10		bits
	VBAT measurement range		2		6	V
	VBAT resolution			6		mV
	VBAT accuracy			± 25		mV
PDM INPUT PORT						
SNR	Signal to Noise Ratio	No signal, Input generated using a 4 th order PDM modulator		118		dB
		No signal, Input generated using a 5 th order PDM modulator		128		
DR	Dynamic Range	20Hz to 20kHz, -60dBFS input signal, A-weighted, Input generated using a 4 th order PDM modulator		117		dB
		20Hz to 20kHz, -60dBFS input signal, A-weighted, Input generated using a 5 th order PDM modulator		127		
FR	Frequency Response	20Hz to 20kHz	-0.1		0	dB
TDM SERIAL AUDIO PORT						
	PCM Sample Rates & FSYNC Input Frequency		8		96	kHz
	SBCLK Input Frequency	I ² S/TDM Operation	0.512		24.57	MHz
	SBCLK Maximum Input Jitter	RMS Jitter below 40 kHz that can be tolerated without performance degradation			1	ns
		RMS Jitter above 40 kHz that can be tolerated without performance degradation			10	ns
	SBCLK Cycles per FSYNC in I ² S and TDM Modes	Values: 64, 96, 128, 192, 256, 384 and 512	64		512	Cycles
PCM PLAYBACK CHARACTERISTICS to $f_s \leq 48\text{ kHz}$						
fs	Sample Rates		8		48	kHz
	Passband LPF Corner			0.454		fs
	Passband Ripple	20 Hz to LPF cutoff	-0.3		0.3	dB
	Stop Band Attenuation	$\geq 0.55\text{ fs}$		60		dB
		$\geq 1\text{ fs}$		65		dB
	Group Delay (ROM MODE)	DC to 0.454 fs			38	1/fs
PCM PLAYBACK CHARACTERISTICS $f_s > 48\text{ kHz}$						
fs	Sample Rates		88.2		96	kHz
	Passband LPF Corner	fs = 96 kHz		0.42		fs
		fs = 192 kHz		0.21		fs
	Passband Ripple	DC to LPF cutoff	-0.5		0.5	dB
	Stop Band Attenuation	$\geq 0.55\text{ fs}$		60		dB
		$\geq 1\text{ fs}$		65		dB

TAS2563

SLASET3C – APRIL 2019 – REVISED MARCH 2021

$T_A = 25\text{ }^\circ\text{C}$, $V_{BAT} = 3.6\text{ V}$, (External PVDD = 12 V), $V_{DD} = 1.8\text{ V}$, $R_L = 8\ \Omega + 33\ \mu\text{H}$, $f_{in} = 1\text{ kHz}$, SSM, $f_s = 48\text{ kHz}$, Gain = 16 dBV (External PVDD Gain=18 dBV), SDZ = 1, Thermal Foldback Disabled, Measured filter free with an Audio Precision with a 22 Hz to 20 kHz un-weighted bandwidth (unless otherwise noted).

PARAMETER		TEST CONDITIONS	MIN	TYP	MAX	UNIT
CURRENT SENSE						
DNR	Dynamic range, DSBGA Package	Un-Weighted, Relative to 0 dBFS		69		dB
DNR	Dynamic range, QFN Package	Un-Weighted, Relative to 0 dBFS		65		dB
THD+N	Total harmonic distortion + noise, DSBGA package	$R_L = 8\ \Omega + 33\ \mu\text{H}$, $f_{in} = 1\text{ kHz}$, $P_{OUT} = 1\text{ W}$		-56		dB
		$R_L = 4\ \Omega + 33\ \mu\text{H}$, $f_{in} = 1\text{ kHz}$, $P_{OUT} = 1\text{ W}$		-57		dB
THD+N	Total harmonic distortion + noise, QFN package	$R_L = 8\ \Omega + 33\ \mu\text{H}$, $f_{in} = 1\text{ kHz}$, $P_{OUT} = 1\text{ W}$		-54.5		dB
		$R_L = 4\ \Omega + 33\ \mu\text{H}$, $f_{in} = 1\text{ kHz}$, $P_{OUT} = 1\text{ W}$		-54.7		dB
	Full-scale input current			2.0		A
	Current-sense accuracy	$R_L = 8\ \Omega + 33\ \mu\text{H}$, $I_{OUT} = 354\text{ mA}_{RMS}$ ($P_{OUT} = 1\text{ W @ }1\text{ kHz}$)		± 1		%
	Current-sense gain error over temperature	0°C to 70°C, 8 Ω , using a 60Hz -40dB pilot tone		± 1		%
	Current-sense gain error over output power	50mW to 0.1 % THD+N level, $f_{in} = 1\text{ kHz}$, 8 Ω , using a 60Hz -40dB pilot tone		± 1.5		%
	LPF passband corner	$f_s = 8\text{ kHz to }48\text{ kHz}$		0.417		fs
		$f_s = 88.2\text{ kHz}$		0.208		fs
		$f_s = 96\text{ kHz}$		0.208		fs
	LPF passband ripple		-0.05		0.05	dB
	LPF stopband attenuation	0.55 fs		60		dB
VOLTAGE SENSE						
DNR	Dynamic range, DSBGA Package	Un-Weighted, Relative 0 dBFS		69		dB
DNR	Dynamic range, QFN Package	Un-Weighted, Relative 0 dBFS		66		dB
THD+N	Total harmonic distortion + noise	$R_L = 8\ \Omega + 33\ \mu\text{H}$, $f_{in} = 1\text{ kHz}$, $P_{OUT} = 1\text{ W}$		-60		dB
		$R_L = 4\ \Omega + 33\ \mu\text{H}$, $f_{in} = 1\text{ kHz}$, $P_{OUT} = 1\text{ W}$		-60		dB
	Full-scale input voltage			14		V_{PK}
	Voltage-sense accuracy	$R_L = 8\ \Omega + 33\ \mu\text{H}$, $I_{OUT} = 354\text{ mA}_{RMS}$ ($P_{OUT} = 1\text{ W}$)		$\pm 0.5\%$		
	Voltage-sense gain error over temperature	0°C to 70°C, 8 Ω , using a 60Hz -40dB pilot tone		$\pm 0.5\%$		
	Voltage-sense gain error over output power	50mV to 0.1 % THD+N level, 8 Ω , using a 60Hz -40dB pilot tone		$\pm 0.5\%$		
	LPF passband corner	$f_s = 14.7\text{ kHz to }48\text{ kHz}$		0.417		fs
		$f_s = 88.2\text{ kHz}$		0.208		fs
		$f_s = 96\text{ kHz}$		0.208		fs
	LPF passband ripple		-0.05		0.05	dB
	LPF stopband attenuation	0.55 fs		60		dB
VOLTAGE/CURRENT SENSE RATIO						
	Gain ratio error over output power	50mW to 0.1 % THD+N level, $f_{in} = 1\text{ kHz}$, 8 Ω , using a 60Hz -40dB pilot tone		$\pm 1\%$		

$T_A = 25\text{ }^\circ\text{C}$, $V_{BAT} = 3.6\text{ V}$, (External PVDD = 12 V), $V_{DD} = 1.8\text{ V}$, $R_L = 8\Omega + 33\text{ }\mu\text{H}$, $f_{in} = 1\text{ kHz}$, SSM, $f_s = 48\text{ kHz}$, Gain = 16 dBV (External PVDD Gain=18 dBV), SDZ = 1, Thermal Foldback Disabled, Measured filter free with an Audio Precision with a 22 Hz to 20 kHz un-weighted bandwidth (unless otherwise noted).

PARAMETER	TEST CONDITIONS	MIN	TYP	MAX	UNIT
Gain ratio drift over temperature	0°C to 70°C		±1%		
V/I phase error			300		ns
TYPICAL CURRENT CONSUMPTION					
Current consumption in hardware shutdown	SDZ = 0, VBAT		1		μA
	SDZ = 0, VDD		1		μA
Current consumption in software shutdown	All Clocks Stopped, VBAT		1		μA
	All Clocks Stopped, VDD		10		μA
Current consumption in idle channel, DSBGA Package	Clocking 0s PCM mode, VBAT		2.7		mA
	Clocking 0s PCM mode, VDD		10.9		mA
Current consumption during active operation with IV sense disabled	$f_s = 48\text{ kHz}$, VBAT		4.6		mA
	$f_s = 48\text{ kHz}$, VDD, DSBGA Package		10.9		mA
	$f_s = 48\text{ kHz}$, VDD, QFN Package		13.2		mA
Current consumption during active operation with IV sense enabled	$f_s = 48\text{ kHz}$, VBAT		4.6		mA
	$f_s = 48\text{ kHz}$, VDD, DSBGA Package		12.5		mA
	$f_s = 48\text{ kHz}$, VDD, QFN Package		14.8		mA
Current consumption during active operation with speaker protection ON	$f_s = 48\text{ kHz}$, VBAT		4.95		mA
	$f_s = 48\text{ kHz}$, VDD, DSBGA Package		28.8		mA
	$f_s = 48\text{ kHz}$, VDD, QFN Package		36		mA
PROTECTION CIRCUITRY					
Thermal shutdown temperature			140		°C
Thermal shutdown retry			1.5		s
VBAT undervoltage lockout threshold (UVLO)	UVLO is asserted	2			V
	UVLO is released			2.55	V
Output short circuit limit	Output to Output, Output to GND, Output to VBST or Output to VBAT Short		3.75		A

6.6 I²C Timing Requirements

T_A = 25 °C, VDD = 1.8 V (unless otherwise noted)

		MIN	NOM	MAX	UNIT
Standard-Mode					
f _{SCL}	SCL clock frequency	0		100	kHz
t _{HD,STA}	Hold time (repeated) START condition. After this period, the first clock pulse is generated.	4			µs
t _{LOW}	LOW period of the SCL clock	4.7			µs
t _{HIGH}	HIGH period of the SCL clock	4			µs
t _{SU,STA}	Setup time for a repeated START condition	4.7			µs
t _{HD,DAT}	Data hold time: For I ² C bus devices	0		3.45	µs
t _{SU,DAT}	Data set-up time	250			ns
t _r	SDA and SCL rise time			1000	ns
t _f	SDA and SCL fall time			300	ns
t _{SU,STO}	Set-up time for STOP condition	4			µs
t _{BUF}	Bus free time between a STOP and START condition	4.7			µs
C _b	Capacitive load for each bus line			400	pF
Fast-Mode					
f _{SCL}	SCL clock frequency	0		400	kHz
t _{HD,STA}	Hold time (repeated) START condition. After this period, the first clock pulse is generated.	0.6			µs
t _{LOW}	LOW period of the SCL clock	1.3			µs
t _{HIGH}	HIGH period of the SCL clock	0.6			µs
t _{SU,STA}	Setup time for a repeated START condition	0.6			µs
t _{HD,DAT}	Data hold time: For I ² C bus devices	0		0.9	µs
t _{SU,DAT}	Data set-up time	100			ns
t _r	SDA and SCL rise time	20 + 0.1 × C _b		300	ns
t _f	SDA and SCL fall time	20 + 0.1 × C _b		300	ns
t _{SU,STO}	Set-up time for STOP condition	0.6			µs
t _{BUF}	Bus free time between a STOP and START condition	1.3			µs
C _b	Capacitive load for each bus line			400	pF
Fast-Mode Plus					
f _{SCL}	SCL clock frequency	0		1000	kHz
t _{HD,STA}	Hold time (repeated) START condition. After this period, the first clock pulse is generated.	0.26			µs
t _{LOW}	LOW period of the SCL clock	0.5			µs
t _{HIGH}	HIGH period of the SCL clock	0.26			µs
t _{SU,STA}	Setup time for a repeated START condition	0.26			µs
t _{HD,DAT}	Data hold time: For I ² C bus devices	0			µs
t _{SU,DAT}	Data set-up time	50			ns
t _r	SDA and SCL Rise Time			120	ns
t _f	SDA and SCL Fall Time			120	ns
t _{SU,STO}	Set-up time for STOP condition				µs
t _{BUF}	Bus free time between a STOP and START condition	0.5			µs
C _b	Capacitive load for each bus line			200	pF

6.7 SPI Timing Requirements

For SPI interface signals over recommended operating conditions (unless otherwise noted). **Note:** All timing specifications are specified by design but not tested at final test.

SYMBOL	PARAMETER	CONDITIONS	IOVDD = 1.8 V		IOVDD = 3.3 V		UNIT
			MIN	MAX	MIN	MAX	
t _{sck}	SCLK Period		60		50		ns
t _{sckh}	SCLK Pulse width High		30		25		ns
t _{sckl}	SCLK Pulse width Low		30		25		ns
t _{lead}	Enable Lead Time		60		50		ns
t _{trail}	Enable Trail Time		60		50		ns
t _{d;seqxfr}	Sequential Transfer Delay		60		50		ns
t _a	Slave DOUT access time			35		25	ns
t _{dis}	Slave DOUT disable time			35		25	ns
t _{su}	DIN data setup time		8		8		ns
t _{h;DIN}	DIN data hold time		8		8		ns
t _{v;DOUT}	DOUT data valid time			35		25	ns
t _r	SCLK Rise Time			4		4	ns
t _f	SCLK Fall Time			4		4	ns
Pd-spi	External Pullup on SPII2CSELZ_MISO_PAD		18		18		kΩ

6.8 PDM Port Timing Requirements

T_A = 25 °C, AVDD = IOVDD = 1.8 V, 20 pF load on all outputs (unless otherwise noted)

			MIN	NOM	MAX	UNIT
t _{SU} (PDM)	PDM IN setup time		20			ns
t _{HLD} (PDM)	PDM IN hold time		3			ns
t _r (PDM)	PDM IN rise time	10 % - 90 % Rise Time			4	ns
t _f (PDM)	PDM IN fall time	90 % - 10 % Fall Time			4	ns

6.9 TDM Port Timing Requirements

T_A = 25 °C, VDD = 1.8 V, 20 pF load on all outputs (unless otherwise noted)

			MIN	NOM	MAX	UNIT
t _H (SBCLK)	SBCLK high period		20			ns
t _L (SBCLK)	SBCLK low period		20			ns
t _{SU} (FSYNC)	FSYNC setup time		6.5			ns
t _{HLD} (FSYNC)	FSYNC hold time		6.5			ns
t _{SU} (SDIN)	SDIN setup time		6.5			ns
t _{HLD} (SDIN)	SDIN hold time		6.5			ns
t _d (DO-SBCLK)	SBCLK to SDOUT delay	50% of SBCLK to 50% of SDOUT			29	ns
t _r (SBCLK)	SBCLK rise time	10% - 90 % Rise Time			8	ns
t _f (SBCLK)	SBCLK fall time	90% - 10 % Fall Time			8	ns

6.10 Timing Diagrams

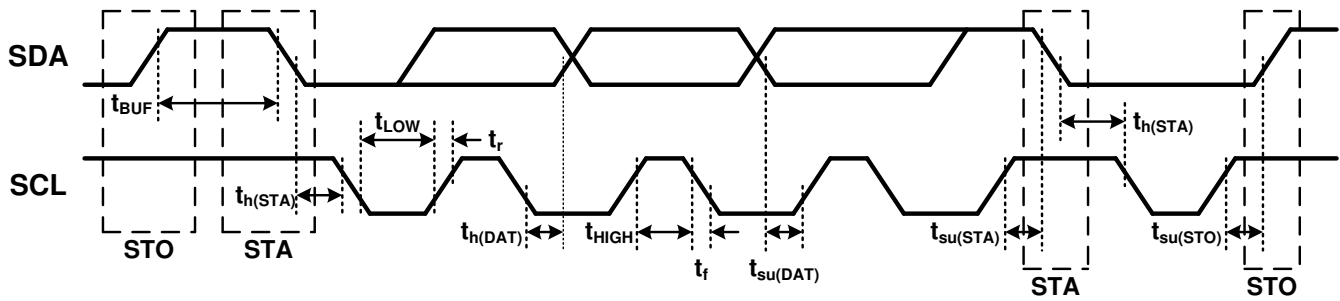

Figure 6-1. I²C Timing Diagram

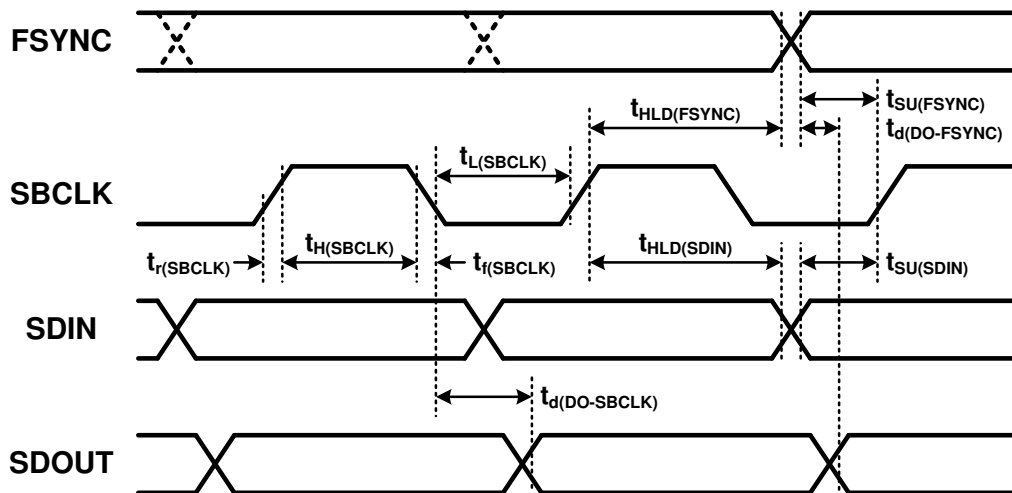

Figure 6-2. TDM Timing Diagram

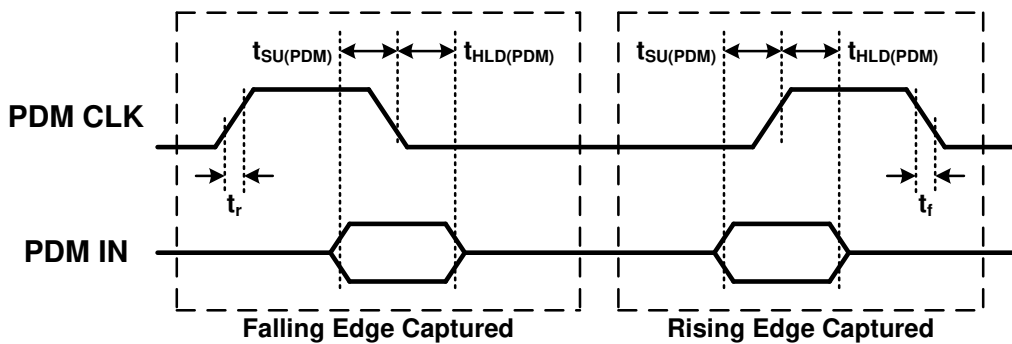

Figure 6-3. PDM Timing Diagram

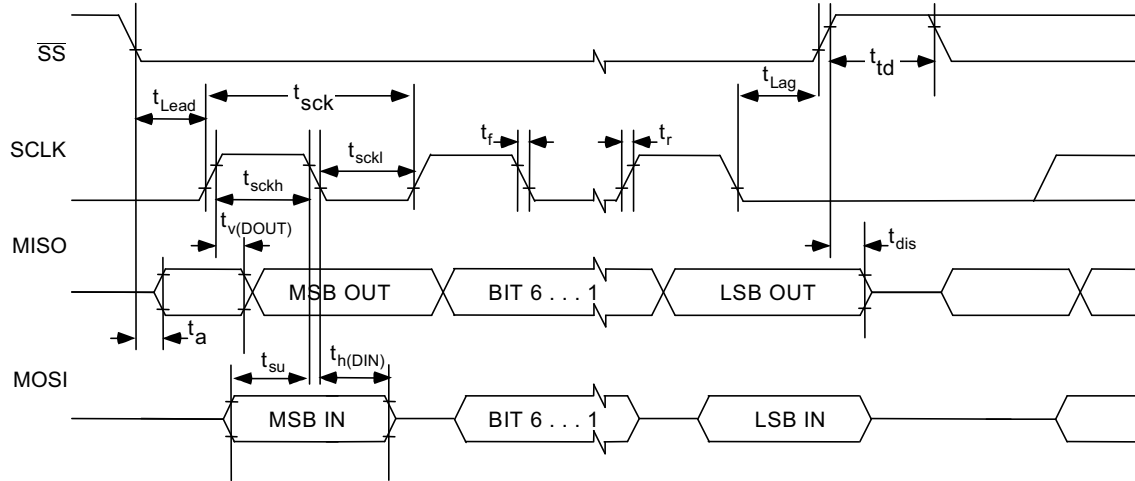

Figure 6-4. SPI Interface Timing Diagram

6.11 Typical Characteristics

At $T_A = 25^\circ\text{C}$, $f_{\text{SPK_AMP}} = 384 \text{ kHz}$, input signal is 1 kHz Sine, unless otherwise noted. Filter used for Load Resistance is $30 \mu\text{H}$, unless otherwise noted.

Note

All the characteristics specified for $\text{PVDD} = 16 \text{ V}$ refer to the DSBGA package.

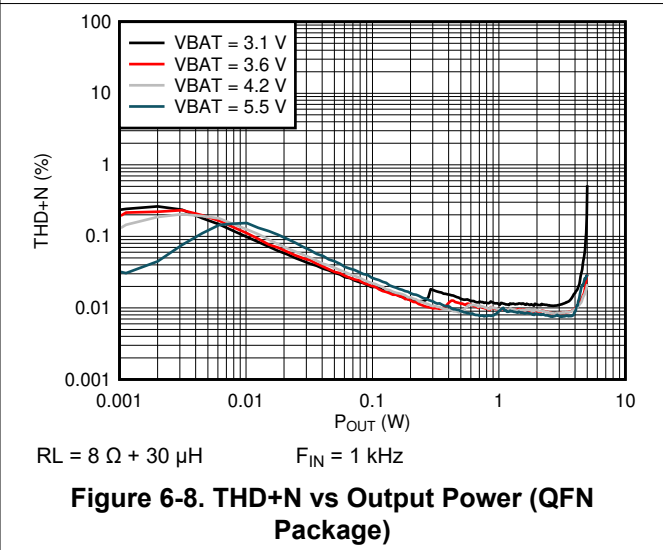
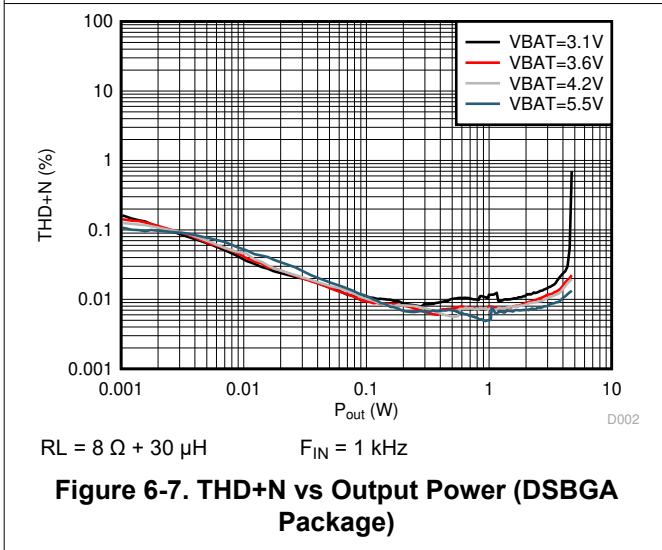
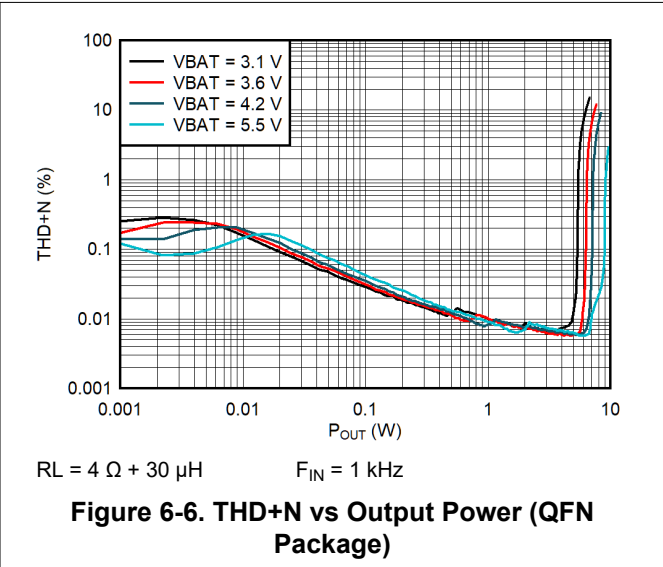
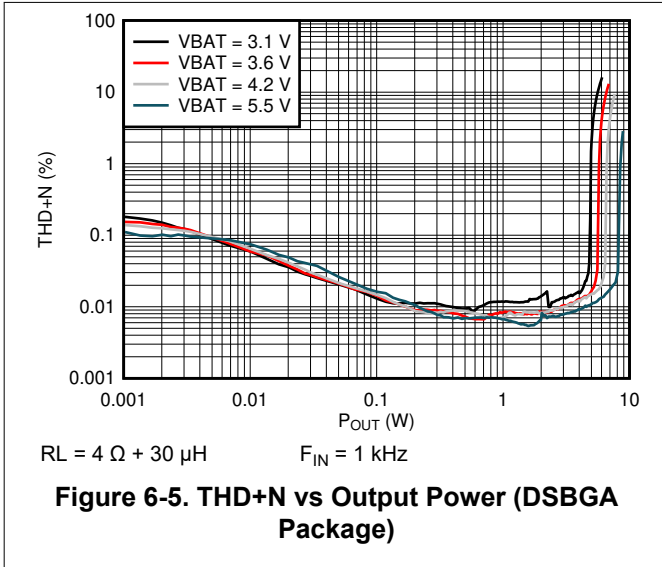

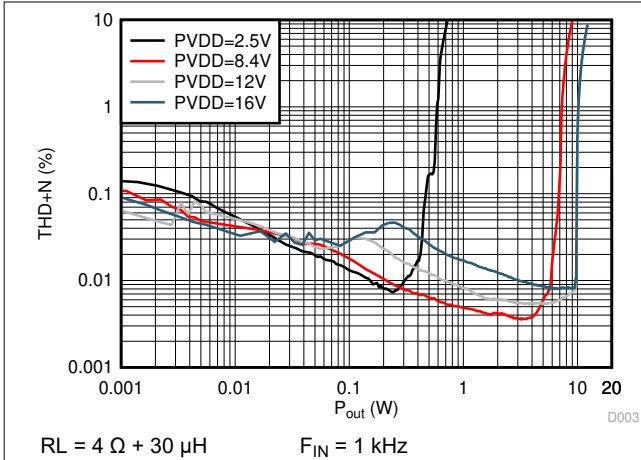

Figure 6-9. THD+N vs Output Power

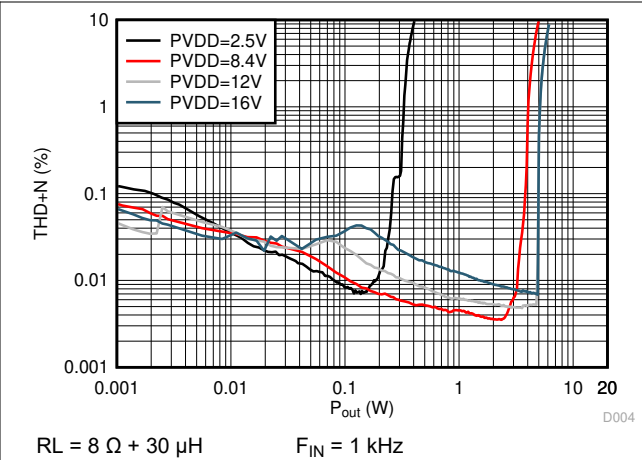

Figure 6-10. THD+N vs Output Power

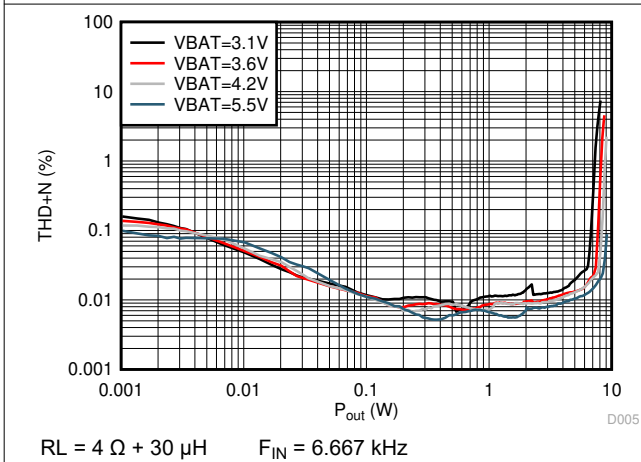

Figure 6-11. THD+N vs Output Power (DSBGA Package)

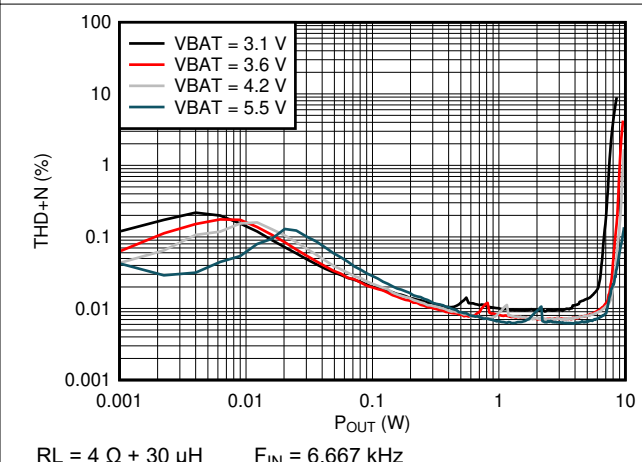

Figure 6-12. THD+N vs Output Power (QFN Package)

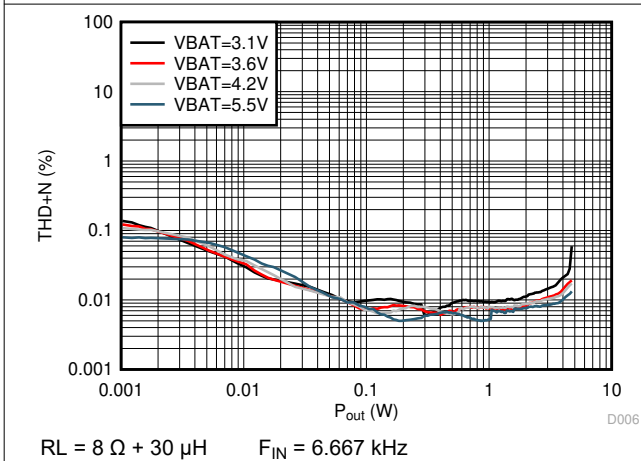

Figure 6-13. THD+N vs Output Power (DSBGA Package)

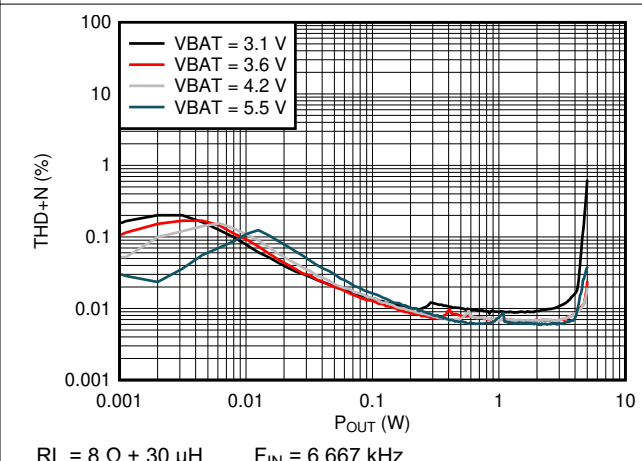
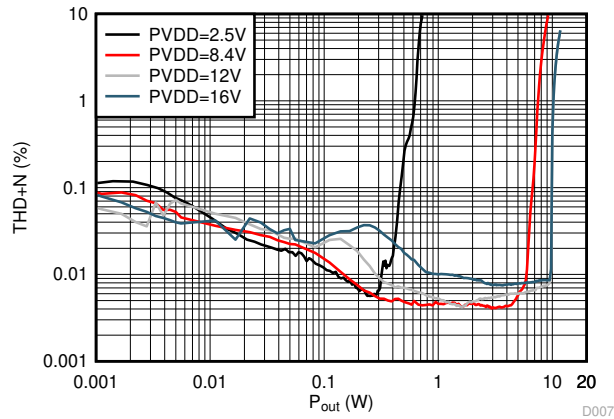
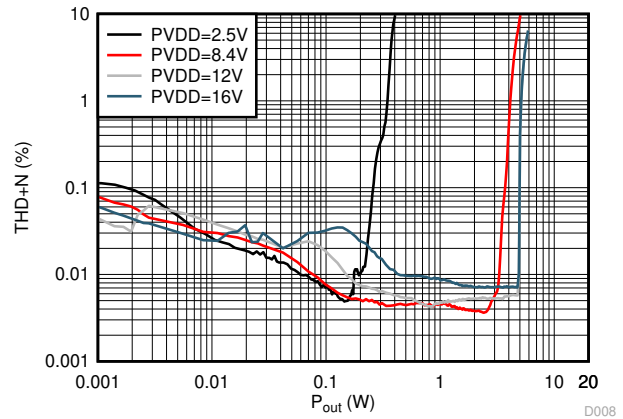

Figure 6-14. THD+N vs Output Power (QFN Package)



RL = 4 Ω + 30 μH $F_{IN} = 6.667$ kHz

Figure 6-15. THD+N vs Output Power



RL = 8 Ω + 30 μH $F_{IN} = 6.667$ kHz

Figure 6-16. THD+N vs Output Power

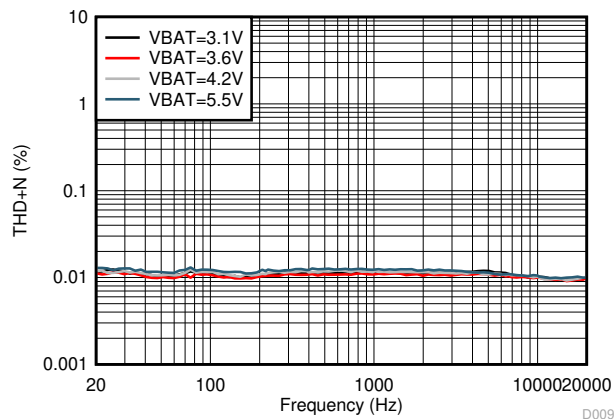

RL = 4 Ω + 30 μH P = 0.1 W

Figure 6-17. THD+N vs Frequency

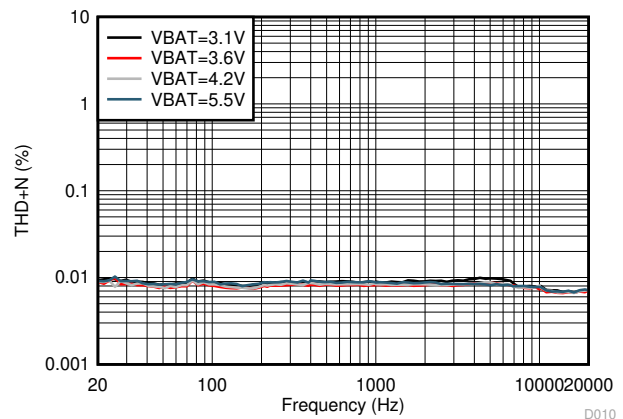

RL = 8 Ω + 30 μH P = 0.1 W

Figure 6-18. THD+N vs Frequency

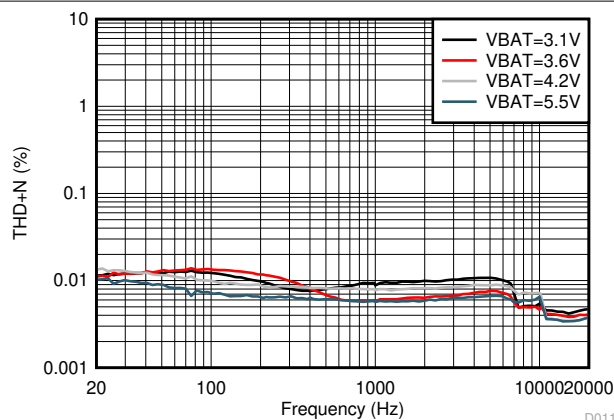

RL = 4 Ω + 30 μH P = 1 W

Figure 6-19. THD+N vs Frequency

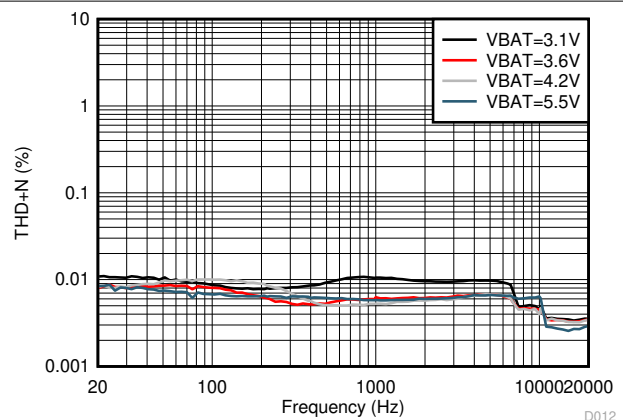

RL = 8 Ω + 30 μH P = 1 W

Figure 6-20. THD+N vs Frequency

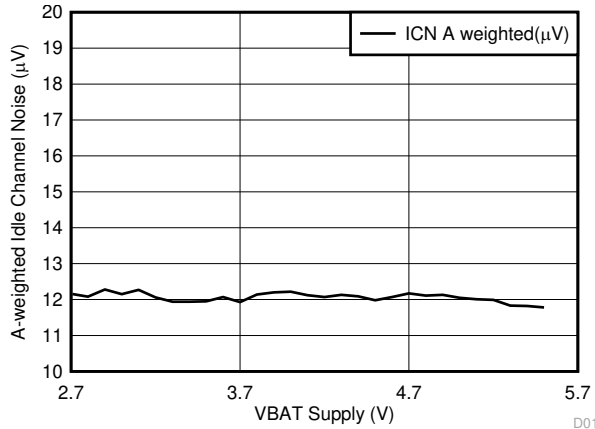

Figure 6-21. Idle Channel Noise (A-Weighted) vs VBAT

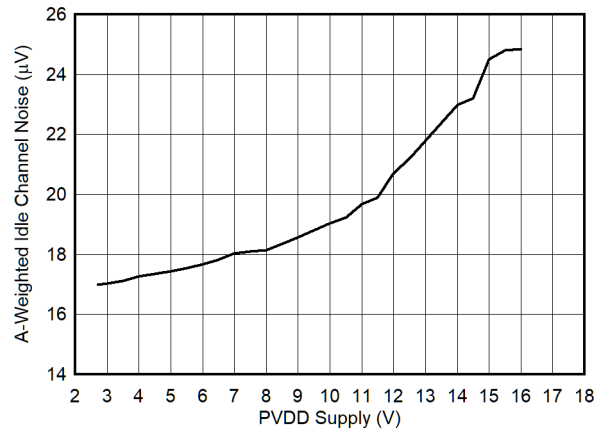

Figure 6-22. Idle Channel Noise (A-Weighted) vs PVDD

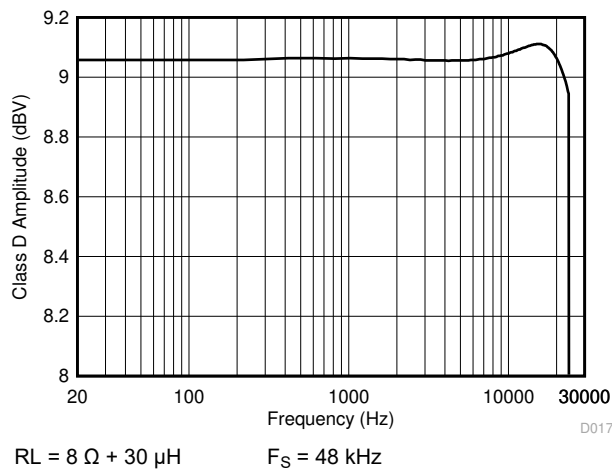

Figure 6-23. Amplitude vs Frequency

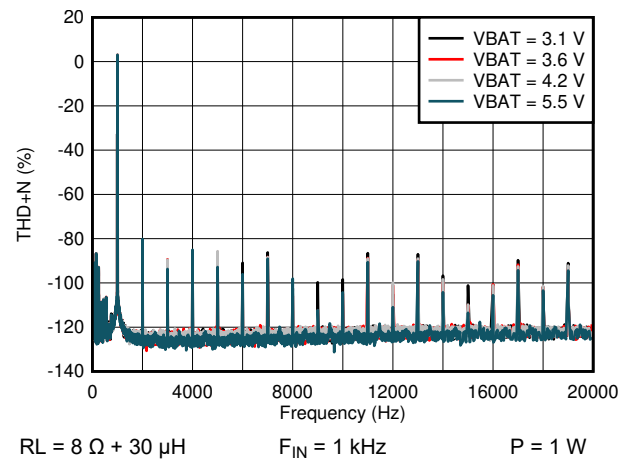

Figure 6-24. FFT Signal Plot

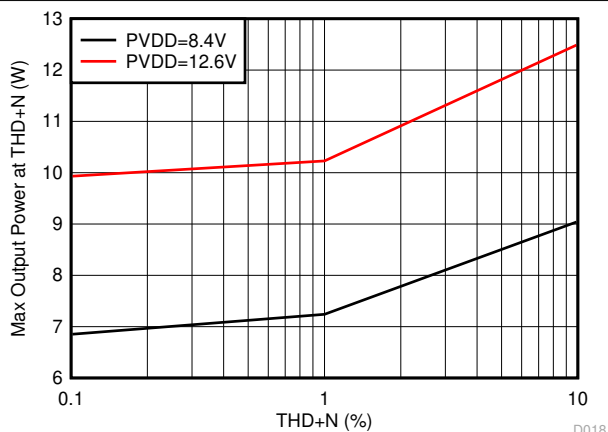

Figure 6-25. Max Output Power vs THD+N

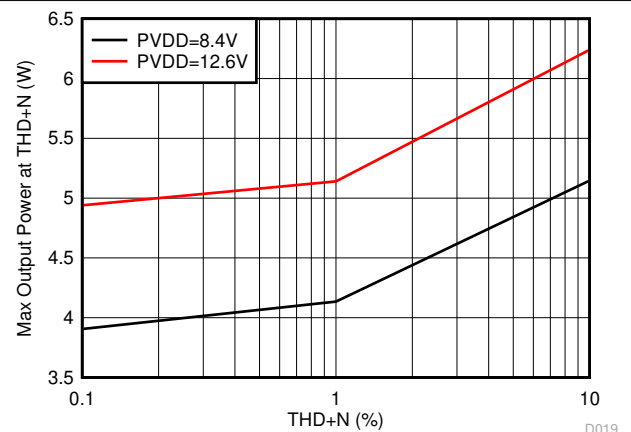

Figure 6-26. Max Output Power vs THD+N

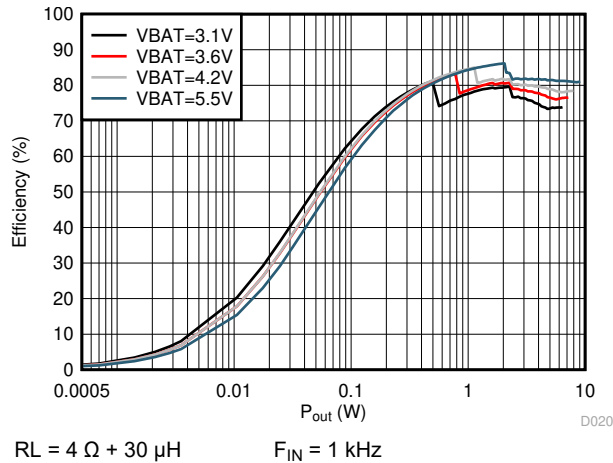

Figure 6-27. Efficiency vs Output Power

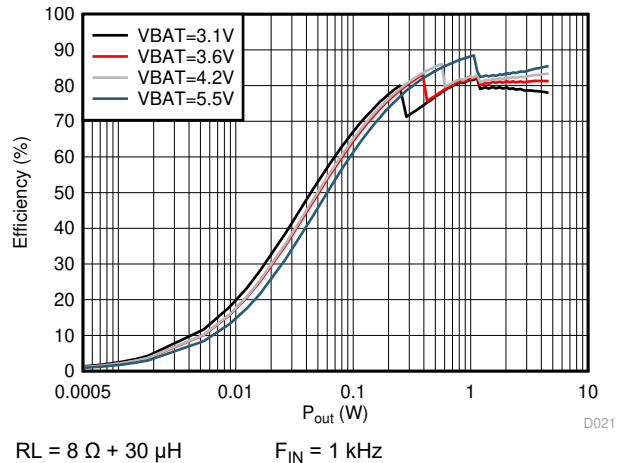

Figure 6-28. Efficiency vs Output Power

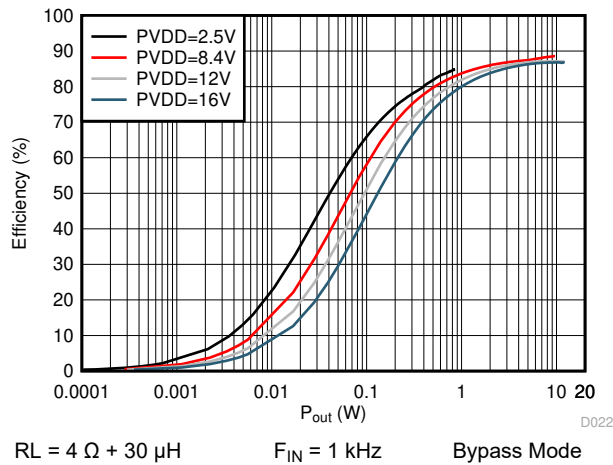

Figure 6-29. Efficiency vs Output Power

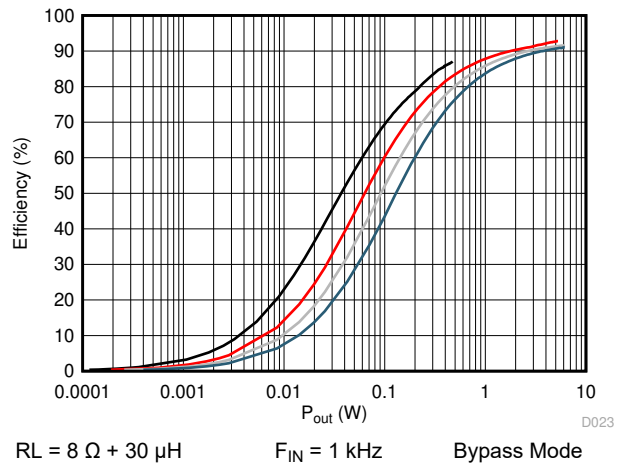

Figure 6-30. Efficiency vs Output Power

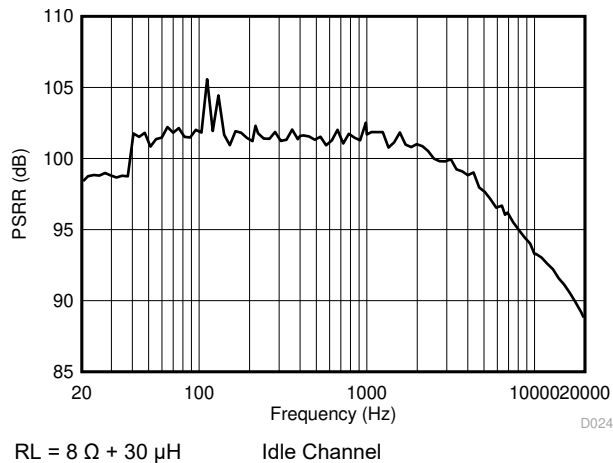

Figure 6-31. AVDD PSRR vs Frequency

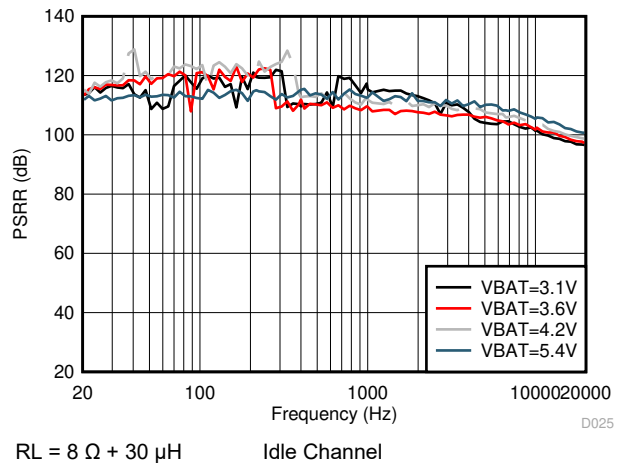
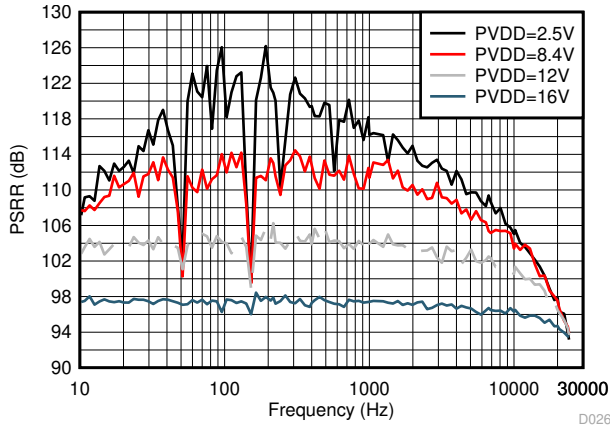
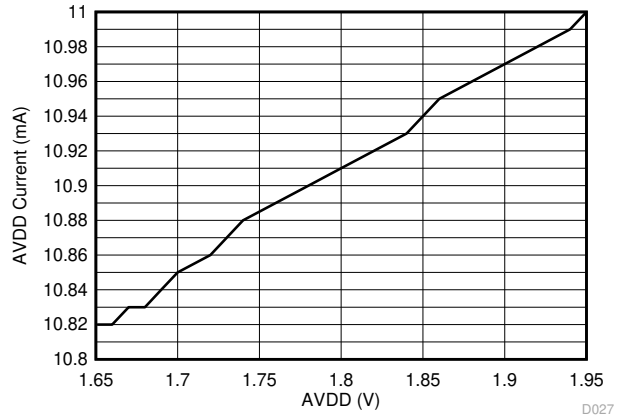

Figure 6-32. VBAT PSRR vs Frequency



RL = 8 Ω + 30 μH Idle Channel

Figure 6-33. PVDD PSRR vs Frequency



Idle Channel

Figure 6-34. AVDD Idle Current vs AVDD (DSBGA Package)

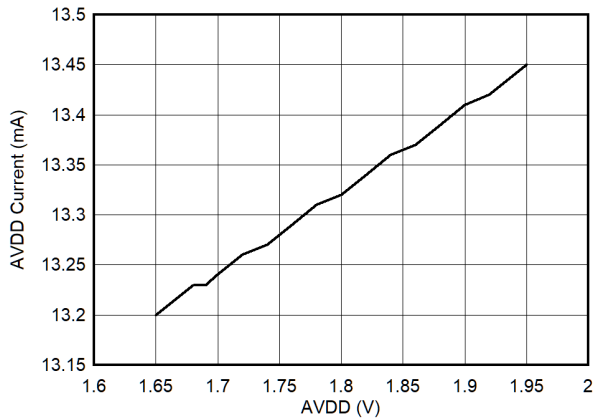

Idle Channel

Figure 6-35. AVDD Idle Current vs AVDD (QFN Package)

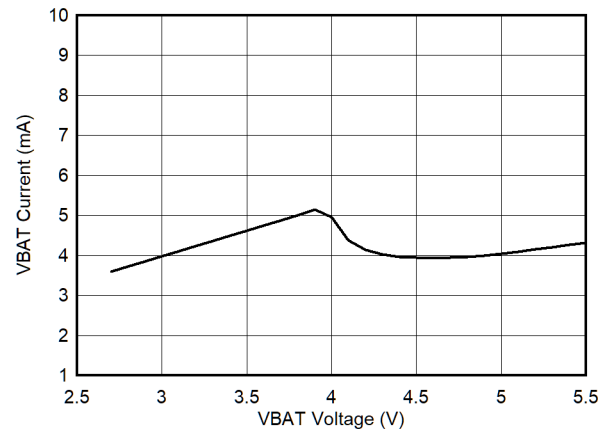

Idle Channel

Figure 6-36. VBAT Idle Current vs VBAT

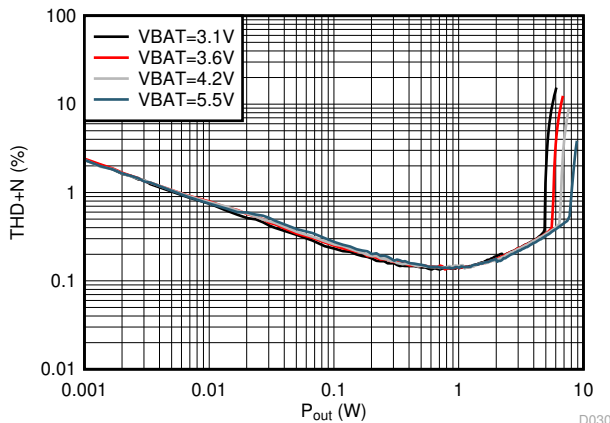

RL = 4 Ω + 30 μH F_{IN} = 1 kHz

Figure 6-37. I-sense THD+N vs Output Power (DSBGA Package)

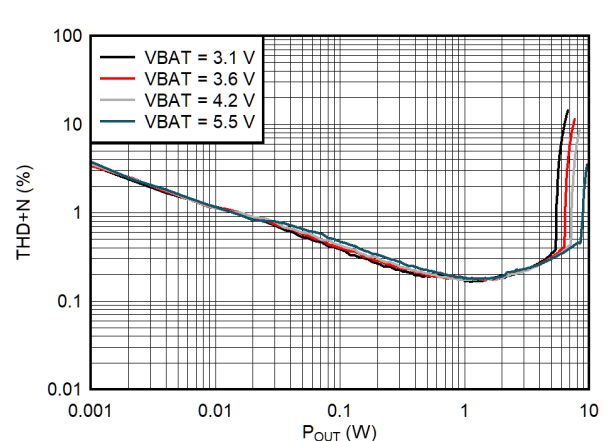

RL = 4 Ω + 30 μH F_{IN} = 1 kHz

Figure 6-38. I-sense THD+N vs Output Power (QFN Package)

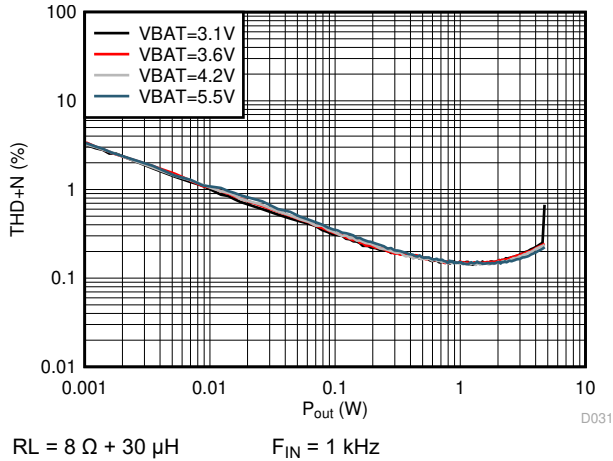

Figure 6-39. I-sense THD+N vs Output Power (DSBGA Package)

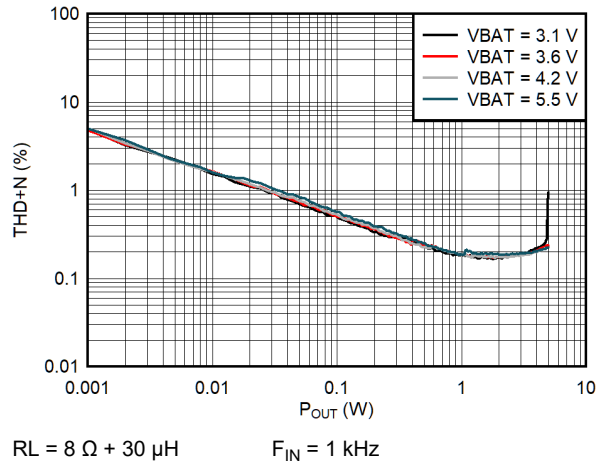

Figure 6-40. I-sense THD+N vs Output Power (QFN Package)

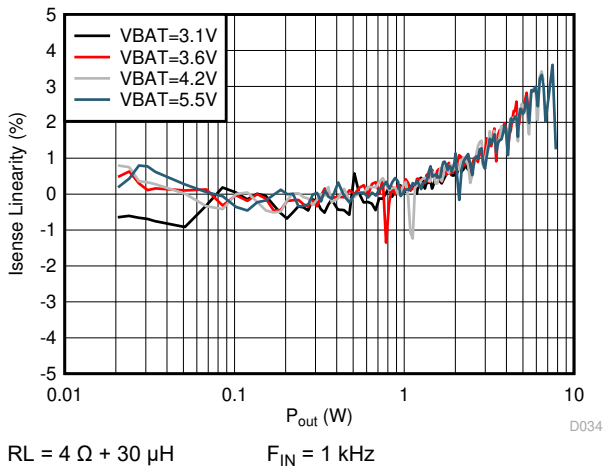

Figure 6-41. I-sense Linearity vs Output Power (DSBGA Package)

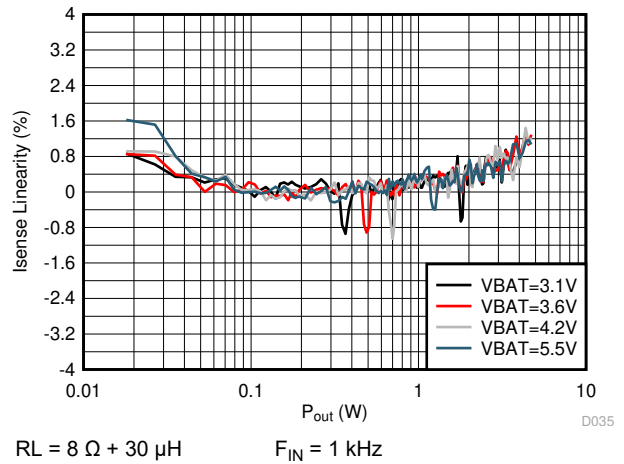

Figure 6-42. I-sense Linearity vs Output Power (QFN Package)

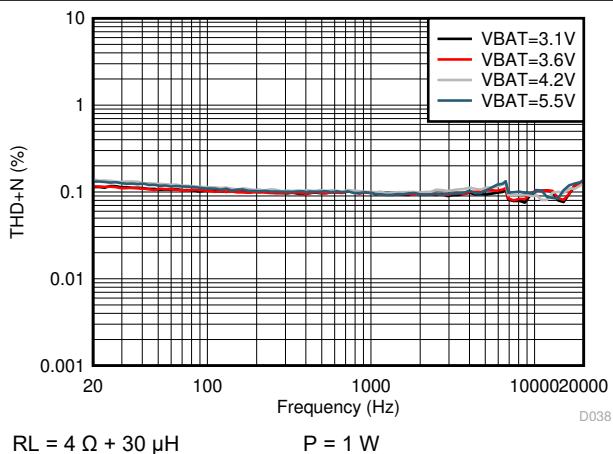

Figure 6-43. I-sense THD+N vs Frequency (DSBGA Package)

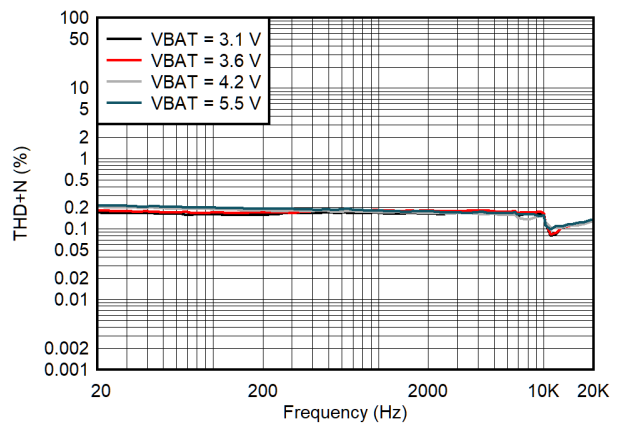

Figure 6-44. I-sense THD+N vs Frequency (QFN Package)

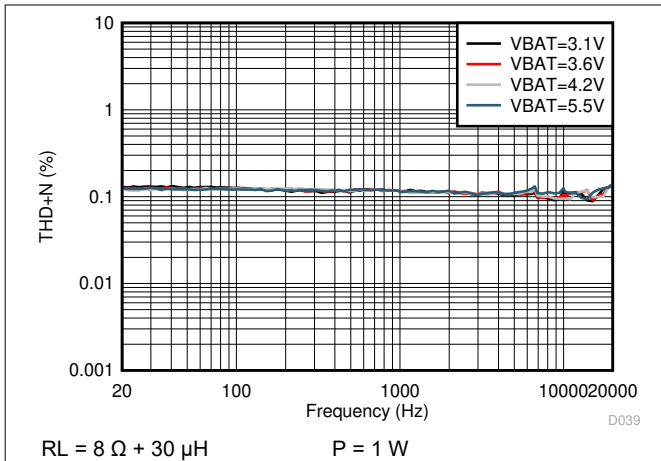

Figure 6-45. I-sense THD+N vs Frequency (DSBGA Package)

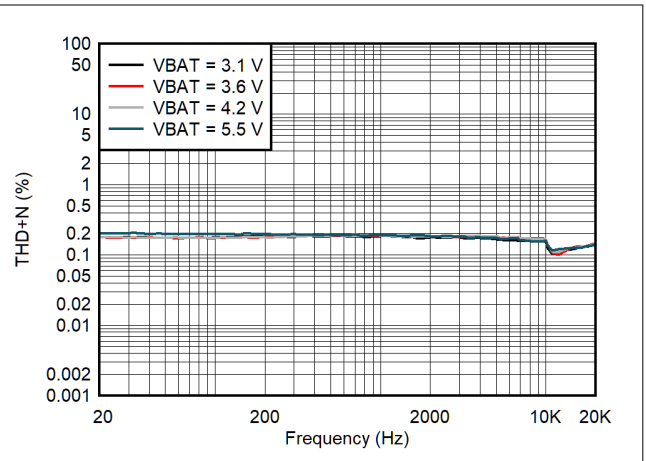

Figure 6-46. I-sense THD+N vs Frequency (QFN Package)

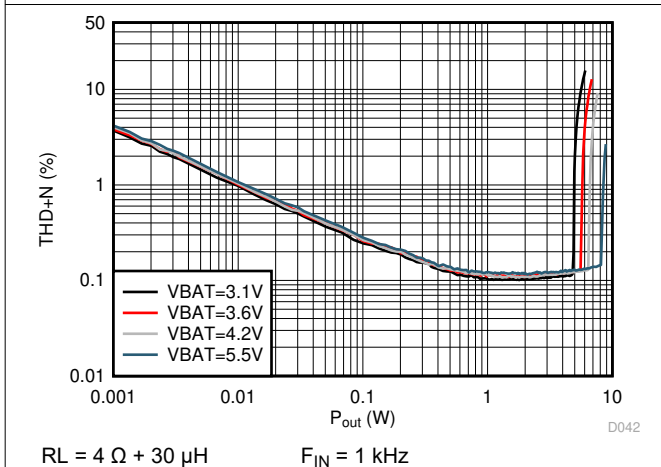

Figure 6-47. V-sense THD+N vs Output Power (DSBGA Package)

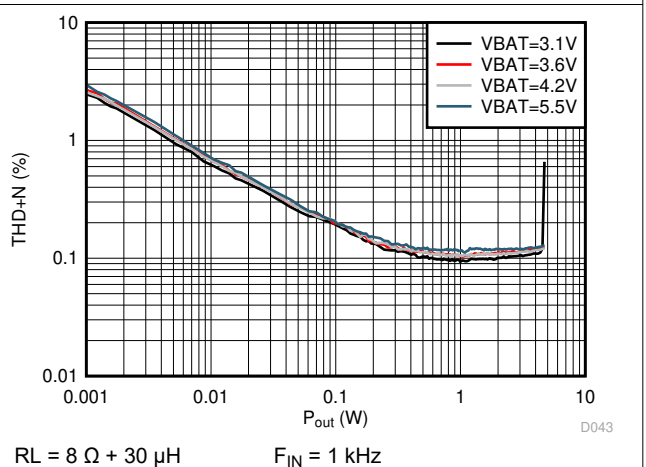

Figure 6-48. V-sense THD+N vs Output Power (QFN Package)

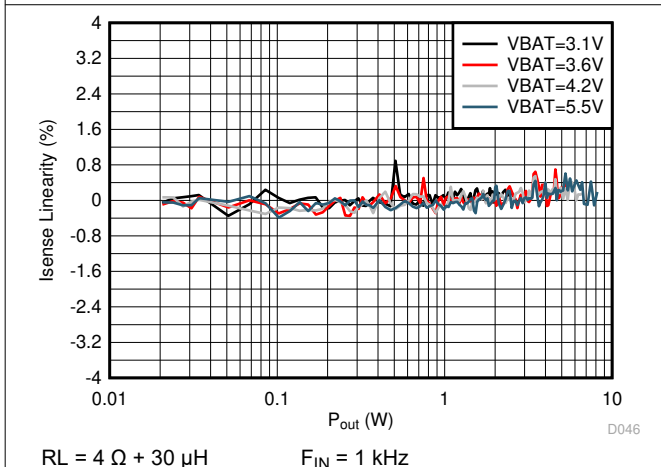

Figure 6-49. V-sense Linearity vs Output Power (DSBGA Package)

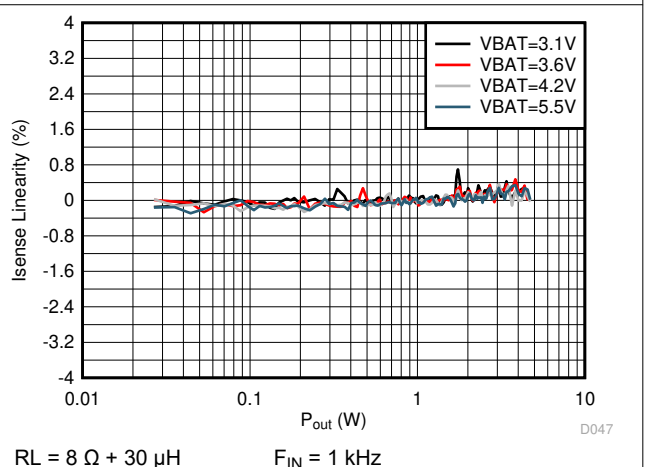
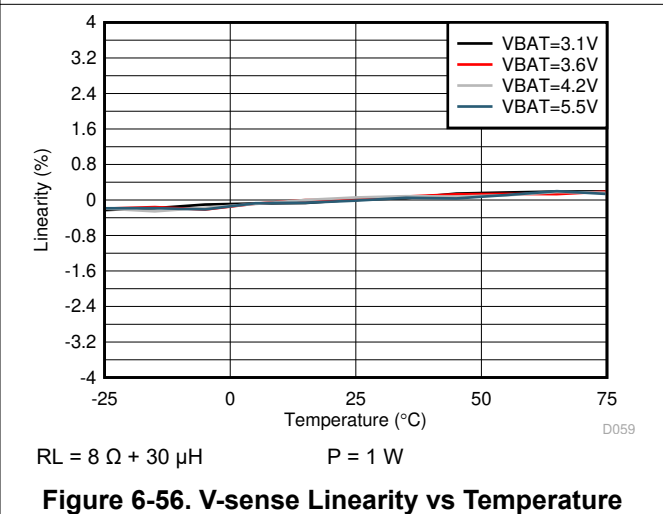
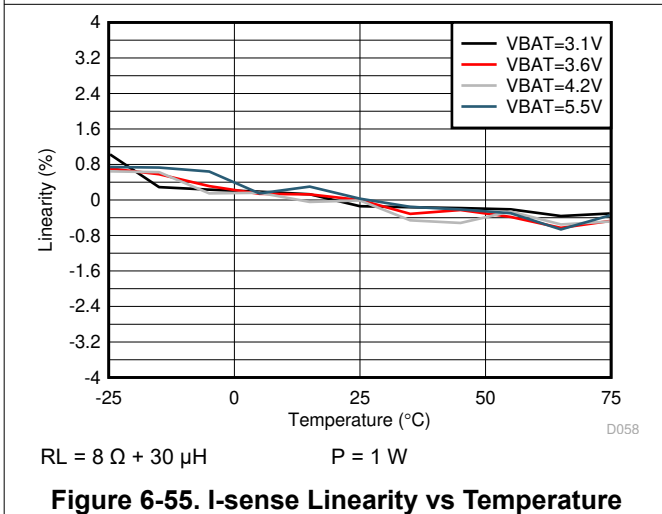
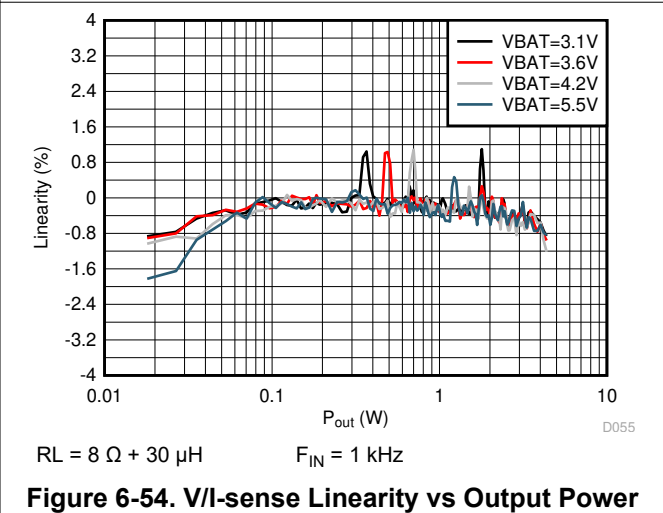
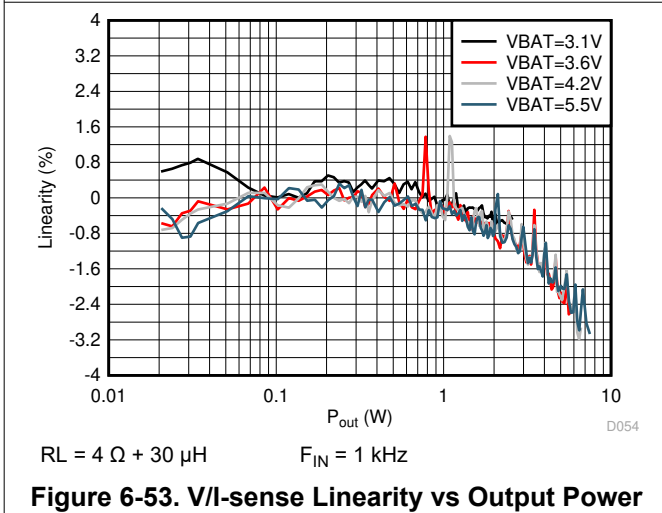
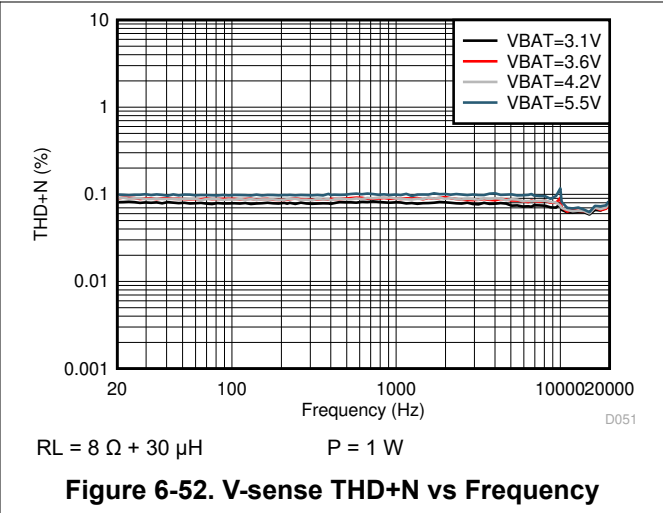
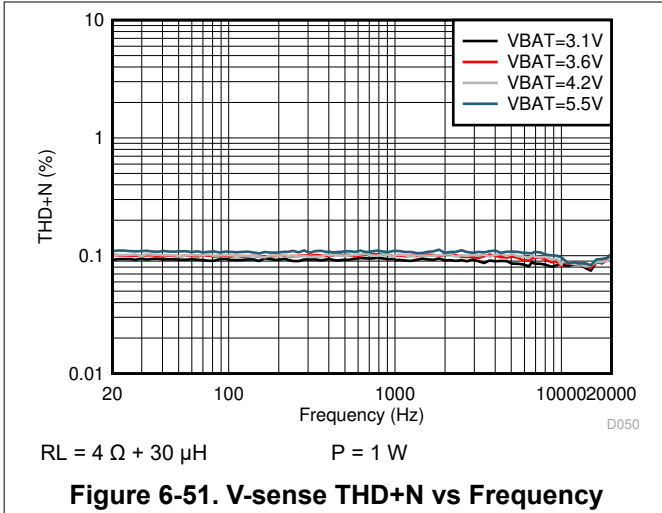

Figure 6-50. V-sense Linearity vs Output Power (QFN Package)



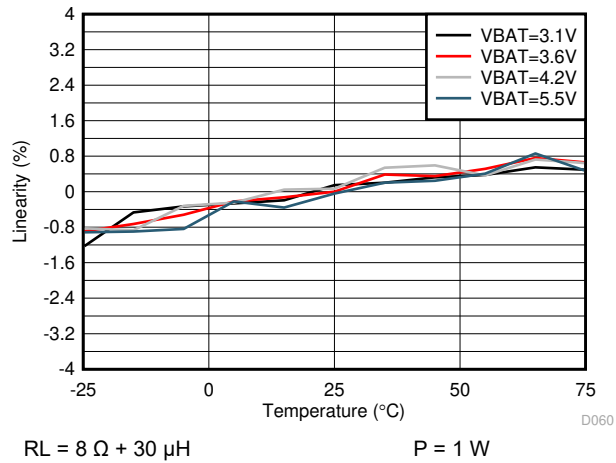

Figure 6-57. V/I-sense Linearity vs Temperature

7 Parameter Measurement Information

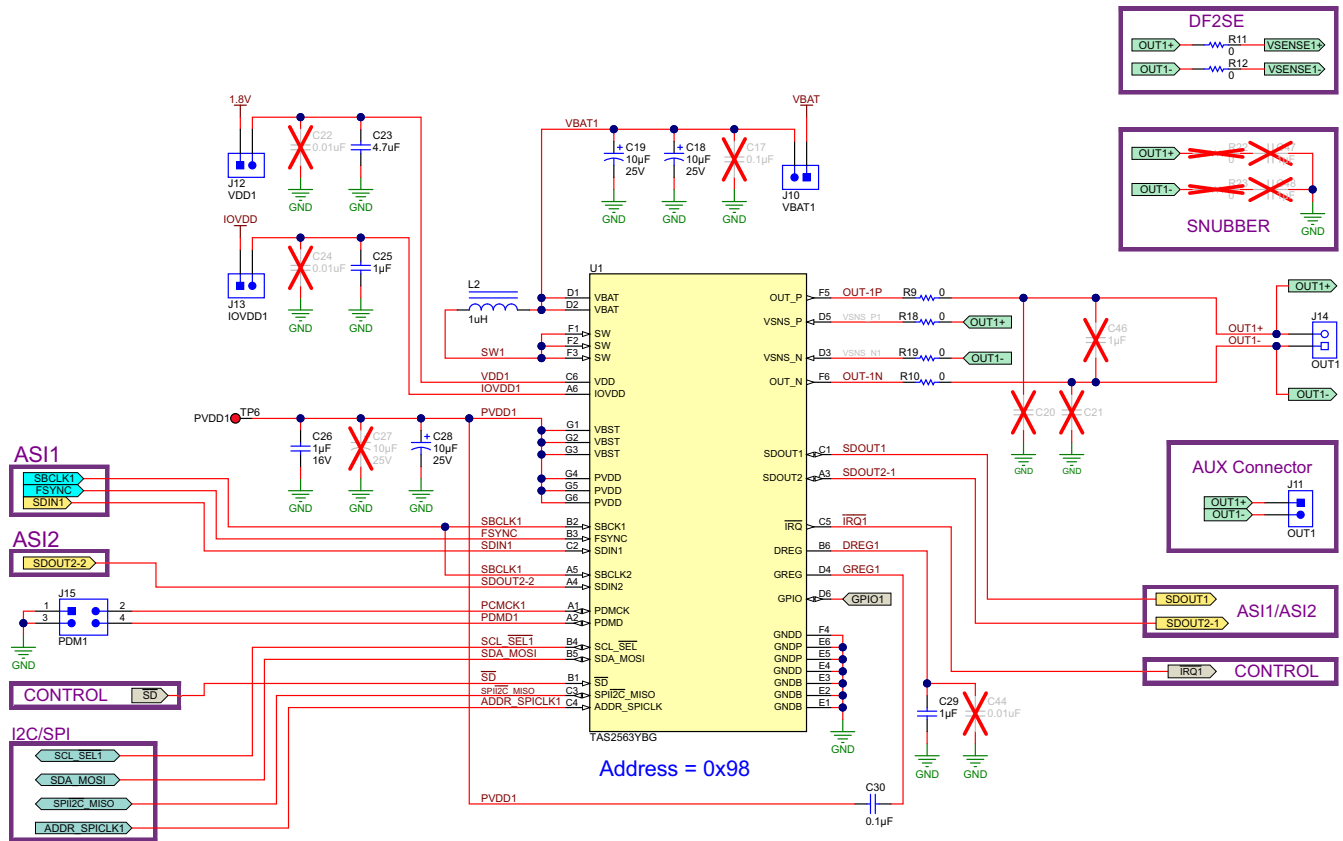

Figure 7-1. TAS2563 Circuit

All typical characteristics for the devices are measured using the Bench EVM and an Audio Precision SYS-2722 Audio Analyzer. A PSIA interface is used to allow the I²S interface to be driven directly into the SYS-2722. Speaker output terminals are connected to the Audio-Precision analyzer analog inputs through a differential-to-single ended (D2S) filter as shown below. The D2S filter contains a 1st order Passive pole at 120 kHz. The D2S filter ensures the TAS2563 high performance class-D amplifier sees a fully differential matched loading at its outputs. This prevents measurement errors due to loading effects of AUX-0025 filter on the class-D outputs.

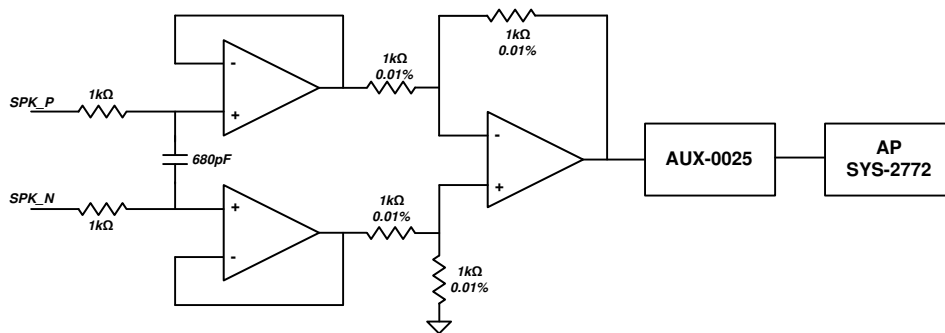

Figure 7-2. Differential To Single Ended (D2S) Filter

8 Detailed Description

8.1 Overview

The TAS2563 is a mono digital input Class-D amplifier optimized for mobile applications where efficient battery operation and small solution size are crucial. It integrates speaker voltage and current sensing and battery tracking limiting with brown out prevention.

8.2 Functional Block Diagram

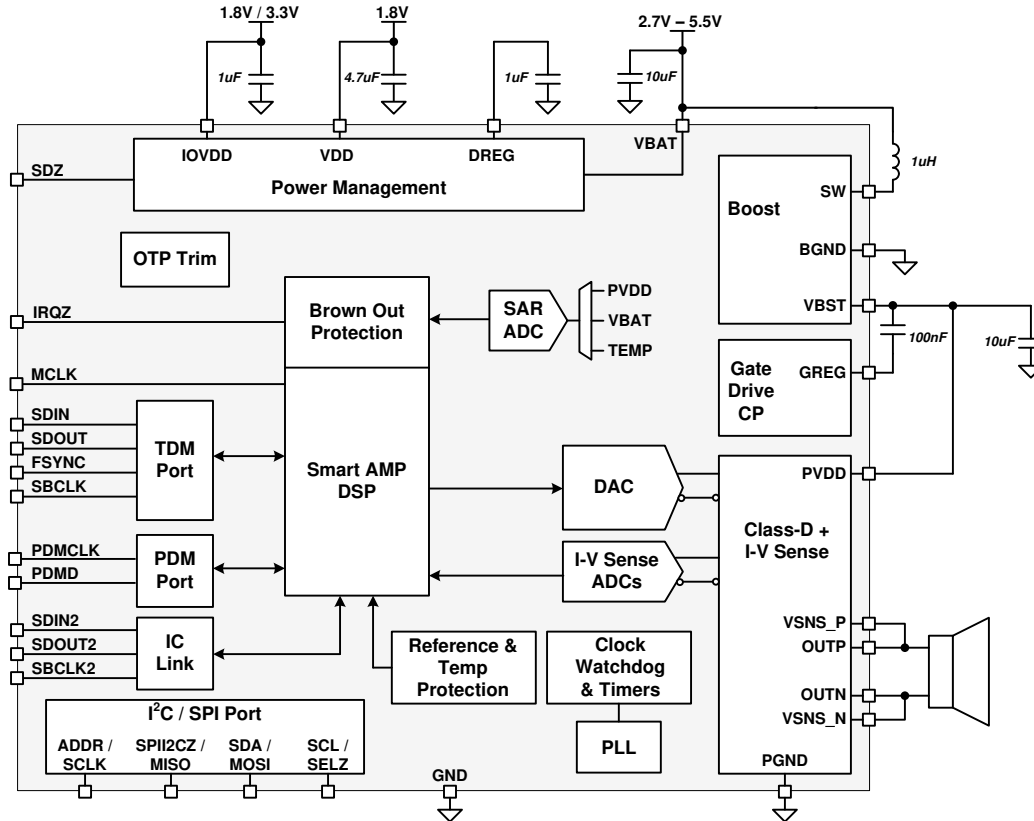

Figure 8-1. Functional Block Diagram

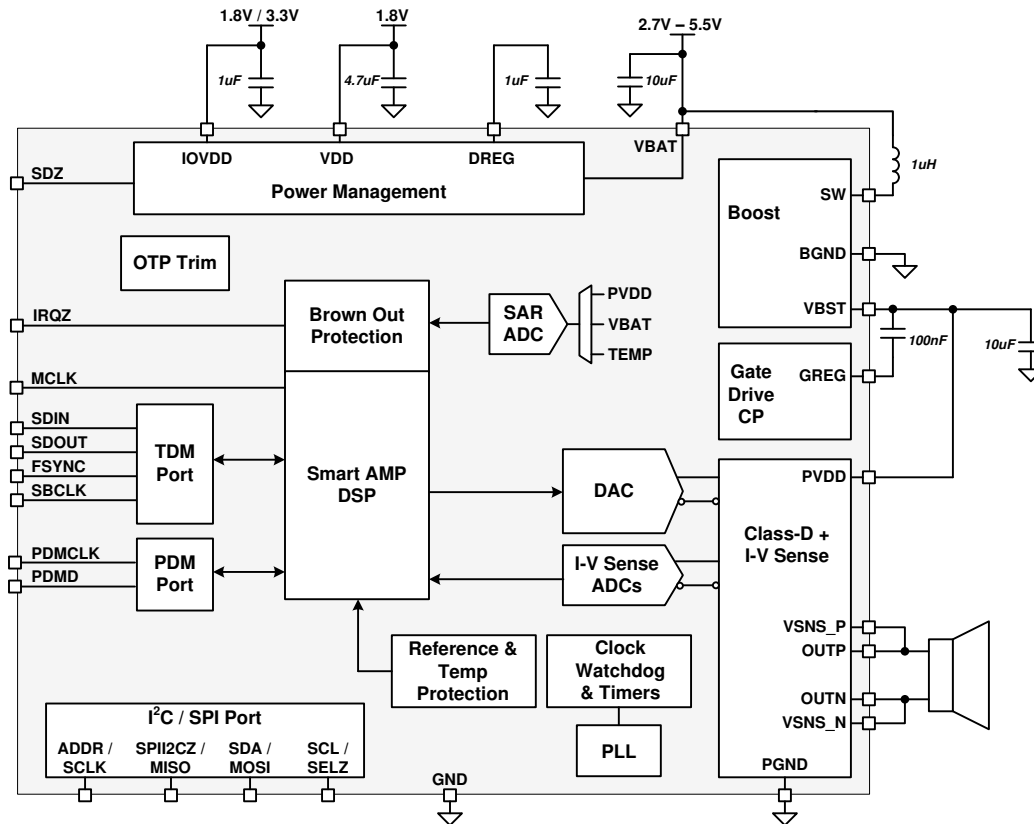

Figure 8-2. TAS2563 QFN Functional Block Diagram

8.3 Feature Description

8.3.1 PurePath™ Console 3 Software

The TAS2563 advanced features and device configuration should be performed using PurePath Console 3 (PPC3) software. The base software PPC3 is downloaded and installed from the TI website. Once installed the TAS2563 application can be download from with-in PPC3. The PCC3 tool will calculate necessary register coefficients that are described in the following sections. It is the recommended method to configure the device. Once the TAS2563 application calculates and updates the device, the registers values can be read back using the PPC3 tool for final system integration.

8.3.2 Device Mode and Address Selection

The TAS2563 has a global 7-bit I²C address 0x48. When enabled the device will additionally respond to I²C commands at this address once it is put in I²C Mode. This is used to speed up device configuration when using multiple TAS2563 devices and programming similar settings across all devices. The I²C ACK / NACK cannot be used during the multi-device writes since multiple devices are responding to the I²C command. The I²C CRC function should be used to ensure each device properly received the I²C commands. At the completion of writing multiple devices using the global address, the CRC at I2C_CKSUM register should be checked on each device using the local address for a proper value. The global I²C address can be disabled using I2C_GBL_EN register. The I²C address is detected by sampling the address pins when SDZ pin is released. Additionally, the address may be re-detected by setting I2C_AD_DET high after power up and the pins will be resampled.

Table 8-1. I²C Global Address Enable

I2C_GBL_EN	SETTING
0	Disabled
1	Enabled (default)

Table 8-2. I²C Global Address Detection

I ² C_AD_DET	SETTING
0	normal (default)
1	Re-detect

8.3.3 General I²C Operation

The I²C bus employs two signals, SDA (data) and SCL (clock), to communicate between integrated circuits in a system using serial data transmission. The address and data 8-bit bytes are transferred most-significant bit (MSB) first. In addition, each byte transferred on the bus is acknowledged by the receiving device with an acknowledge bit. Each transfer operation begins with the master device driving a start condition on the bus and ends with the master device driving a stop condition on the bus. The bus uses transitions on the data terminal (SDA) while the clock is at logic high to indicate start and stop conditions. A high-to-low transition on SDA indicates a start, and a low-to-high transition indicates a stop. Normal data-bit transitions must occur within the low time of the clock period. shows a typical sequence.

To configure the TAS2563 for I²C operation set the SPII2CZ_MISO pin to ground. The I²C address can then be set using pins ADDR_SPICLK according to [Table 8-3](#). The pin configures the two LSB bits of the following 7-bit binary address A6-A0 of 10011xx. This permits the I²C address of TAS2563 to be 0x4C(7-bit) through 0x4F(7-bit). For example, if ADDR_SPICLK is connected to ground the I²C address for the TAS2563 would be 0x4C(7-bit). This is equivalent to 0x98 (8-bit) for writing and 0x99 (8-bit) for reading. The ADDR_SPICLK should be only pulled high to the IOVDD pin voltage.

Table 8-3. I²C Mode Address Selection

I ² C SLAVE ADDRESS	ADDR_SPICLK PIN
0x48 (global address)	NA
0x4C	GND
0x4D	10k to GND
0x4E	10k to VDD
0x4F	VDD

The master generates the 7-bit slave address and the read/write (R/W) bit to open communication with another device and then waits for an acknowledge condition. The device holds SDA low during the acknowledge clock period to indicate acknowledgment. When this occurs, the master transmits the next byte of the sequence. Each device is addressed by a unique 7-bit slave address plus R/W bit (1 byte). All compatible devices share the same signals via a bi-directional bus using a wired-AND connection.

Use external pull-up resistors for the SDA and SCL signals to set the logic-high level for the bus. Pull Up Resistor can be calculated as per the table below. For Capacitive Loads different from mentioned below in table, use interpolated values.

Do not allow the SDA and SCL voltages to exceed the device supply voltage, IOVDD. The I²C pins are fault tolerant and will not load the I²C bus when the device is powered down.

Table 8-4. I²C Pull Up Resistor Selection

I ² C Mode of Operation	Capacitive Load	Recommended Pull Up Resistor
Standard/Fast	10pF	500 Ω to 4.7 KΩ
	400pF	500 Ω to 1 KΩ
Fast Mode Plus	10pF	500 Ω to 4 KΩ
	550pF	350 Ω to 400 Ω

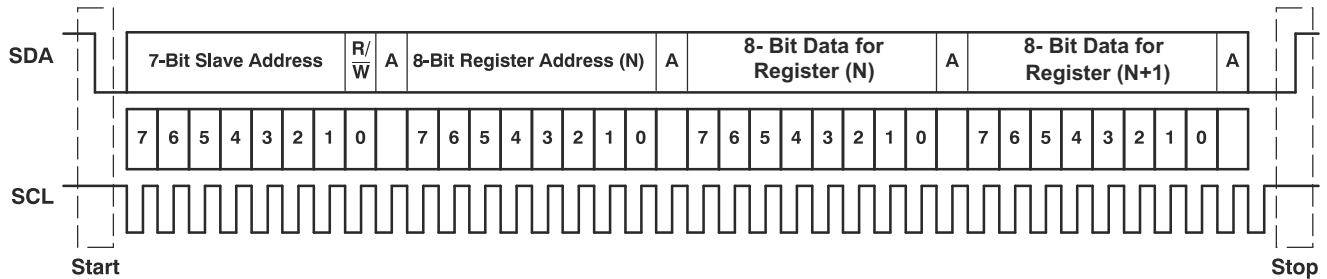

Figure 8-3. Typical I²C Sequence

There is no limit on the number of bytes that can be transmitted between start and stop conditions. When the last word transfers, the master generates a stop condition to release the bus. Figure 8-3 shows a generic data transfer sequence.

8.3.4 General SPI Operation

The TAS2563 operates as an SPI slave over the IOVDD voltage range. To enable SPI mode the SPII2CZ_MISO pin is pulled to IOVDD using a resistor. During the device power up the pin state is queried and if high will enter SPI mode.

In the SPI control mode, the TAS2563 uses the terminals SCL_SELZ as SS, ADDR_SPICLK as SCLK, SPII2CZ_MISO as MISO, SDA_MOSI as MOSI; The SPI port allows full-duplex, synchronous, serial communication between a host processor (the master) and peripheral devices (slaves). The SPI master (in this case, the host processor) generates the synchronizing clock (driven onto SCLK) and initiates transmissions. The SPI slave device depends on a master to start and synchronize transmissions. A transmission begins when initiated by an SPI master. The byte from the SPI master begins shifting in on the slave MOSI terminal under the control of the master serial clock (driven onto SCLK). As the byte shifts in on the MOSI terminal, a byte shifts out on the MISO terminal to the master shift register.

The TAS2563 interface is designed so that with a clock-phase bit setting of 1 (typical microprocessor SPI control bit CPHA = 1), the master begins driving its MOSI terminal and the slave begins driving its MISO terminal on the first serial clock edge. The SSZ terminal can remain low between transmissions; however, the TAS2563 only interprets the first 8 bits transmitted after the falling edge of SSZ as a command byte, and the next 8 bits as a data byte only if writing to a register. Reserved register bits should be written to their default values. The TAS2563 is entirely controlled by registers. Reading and writing these registers is accomplished by an 8-bit command sent to the MOSI terminal of the part prior to the data for that register. The command is structured as shown in Table 8-5 below. The first 7 bits specify the address of the register which is being written or read, from 0 to 127 (decimal). The command word ends with an R/W bit, which specifies the direction of data flow on the serial bus. In the case of a register write, the R/W bit should be set to 0. A second byte of data is sent to the MOSI terminal and contains the data to be written to the register. Reading of registers is accomplished in a similar fashion. The 8-bit command word sends the 7-bit register address, followed by the R/W bit = 1 to signify a register read is occurring. The 8-bit register data is then clocked out of the part on the MISO terminal during the second 8 SCLK clocks in the frame.

Table 8-5. Command Word

Bit 7	Bit 6	Bit 5	Bit 4	Bit 3	Bit 2	Bit 1	Bit 0
ADDR(6)	ADDR(5)	ADDR(4)	ADDR(3)	ADDR(2)	ADDR(1)	ADDR(0)	R/WZ

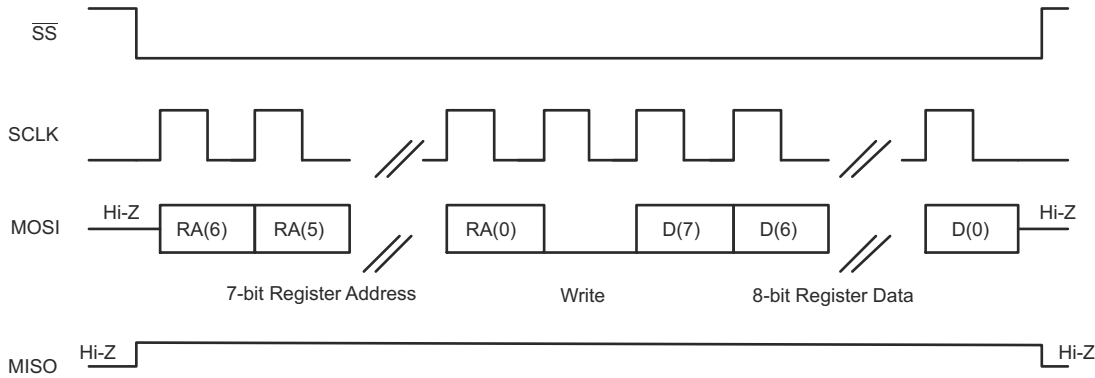

Figure 8-4. SPI Timing Diagram for Register Write

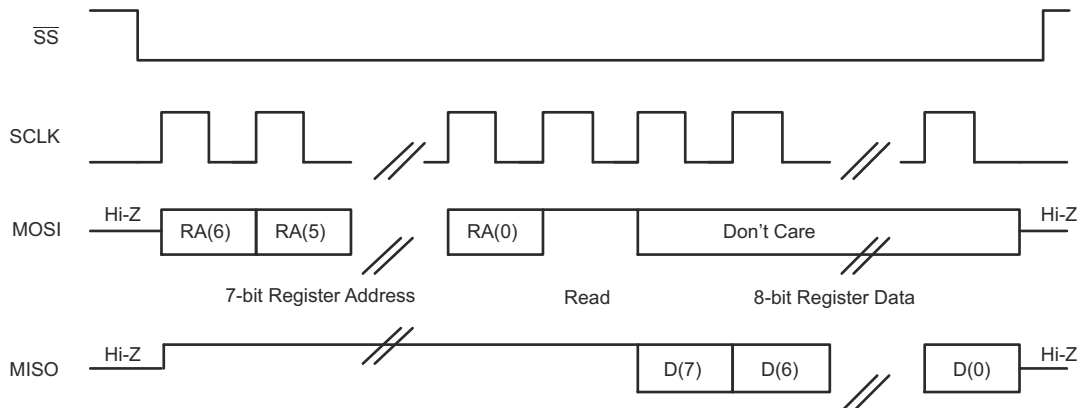

Figure 8-5. SPI Timing Diagram for Register Read

8.3.5 Single-Byte and Multiple-Byte Transfers

The serial control interface supports both single-byte and multiple-byte read/write operations for all registers. During multiple-byte read operations, the TAS2563 responds with data, a byte at a time, starting at the register assigned, as long as the master device continues to respond with acknowledges.

The TAS2563 supports sequential I²C addressing. For write transactions, if a register is issued followed by data for that register and all the remaining registers that follow, a sequential I²C write transaction has taken place. For I²C sequential write transactions, the register issued then serves as the starting point, and the amount of data subsequently transmitted, before a stop or start is transmitted, determines to how many registers are written.

8.3.6 Single-Byte Write

As shown in Figure 8-6, a single-byte data-write transfer begins with the master device transmitting a start condition followed by the I²C device address and the read/write bit. The read/write bit determines the direction of the data transfer. For a write-data transfer, the read/write bit must be set to 0. After receiving the correct I²C device address and the read/write bit, the TAS2563 responds with an acknowledge bit. Next, the master transmits the register byte corresponding to the device internal memory address being accessed. After receiving the register byte, the device again responds with an acknowledge bit. Finally, the master device transmits a stop condition to complete the single-byte data-write transfer.

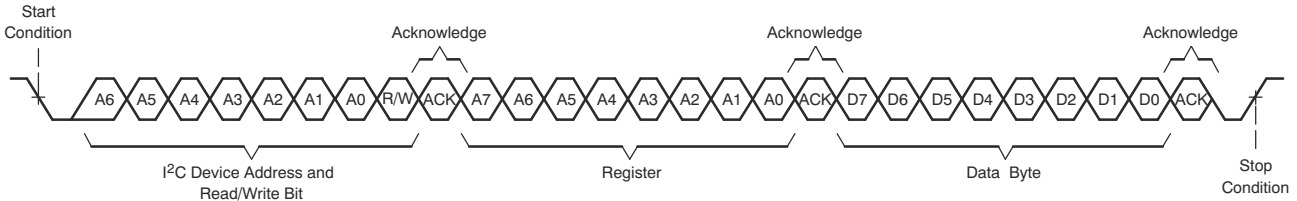

Figure 8-6. Single-Byte Write Transfer

8.3.7 Multiple-Byte Write and Incremental Multiple-Byte Write

A multiple-byte data write transfer is identical to a single-byte data write transfer except that multiple data bytes are transmitted by the master device to the TAS2563 as shown in Figure 8-7. After receiving each data byte, the device responds with an acknowledge bit.

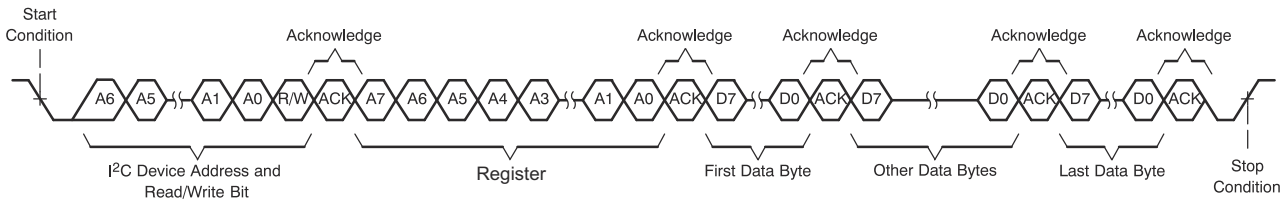

Figure 8-7. Multi-Byte Write Transfer

8.3.8 Single-Byte Read

As shown in Figure 8-8, a single-byte data-read transfer begins with the master device transmitting a start condition followed by the I²C device address and the read/write bit. For the data-read transfer, both a write followed by a read are actually done. Initially, a write is done to transfer the address byte of the internal memory address to be read. As a result, the read/write bit is set to a 0.

After receiving the TAS2563 address and the read/write bit, the device responds with an acknowledge bit. The master then sends the internal memory address byte, after which the device issues an acknowledge bit. The master device transmits another start condition followed by the TAS2563 address and the read/write bit again. This time, the read/write bit is set to 1, indicating a read transfer. Next, the TAS2563 transmits the data byte from the memory address being read. After receiving the data byte, the master device transmits a not-acknowledge followed by a stop condition to complete the single-byte data read transfer.

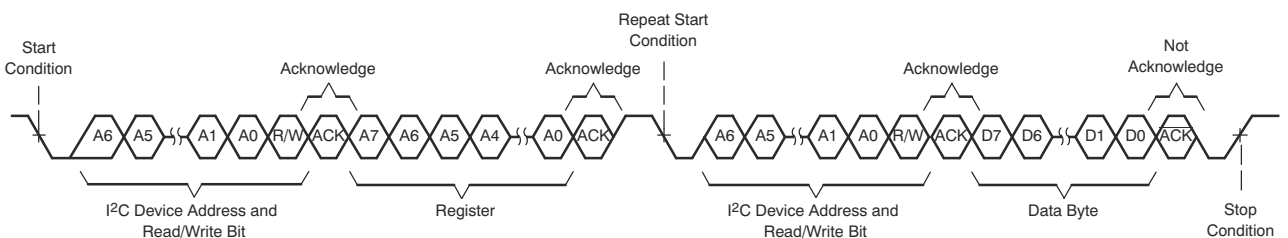

Figure 8-8. Single-Byte Read Transfer

8.3.9 Multiple-Byte Read

A multiple-byte data-read transfer is identical to a single-byte data-read transfer except that multiple data bytes are transmitted by the TAS2563 to the master device as shown in Figure 8-9. With the exception of the last data byte, the master device responds with an acknowledge bit after receiving each data byte.

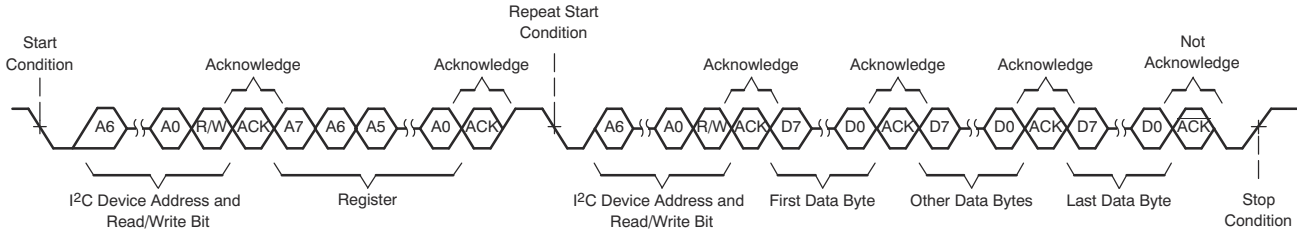

Figure 8-9. Multi-Byte Read Transfer

8.3.10 Register Organization

Device configuration and coefficients are stored using a page and book scheme. Each page contains 128 bytes and each book contains 256 pages. All device configuration registers are stored in book 0, page 0, which is the default setting at power up (and after a software reset). The book and page can be set by the *BOOK[7:0]* and *PAGE[7:0]* registers respectively.

8.3.11 Operational Modes

8.3.11.1 Hardware Shutdown

The device enters Hardware Shutdown mode if the SDZ pin is asserted low. In Hardware Shutdown mode, the device consumes the minimum quiescent current from VDD and VBAT supplies. All registers lose state in this mode and I²C communication is disabled.

In normal shutdown mode if SDZ is asserted low while audio is playing, the device will ramp down volume on the audio, stop the Class-D switching, power down analog and digital blocks and finally put the device into Hardware Shutdown mode. If configured in normal with timeout shutdown mode the device will force a hard shutdown after a timeout of the configurable shutdown timer. Finally the device can be configured for hard shutdown and will not attempt to gracefully stop the audio channel.

Table 8-6. Shutdown Control

<i>SDZ_MODE[1:0]</i>	SETTING
00	Normal Shutdown with Timer (default)
01	Immediate Shutdown
10	Normal Shutdown
11	Reserved

Table 8-7. Shutdown Control

<i>SDZ_TIMEOUT[1:0]</i>	SETTING
00	2 ms
01	4 ms
10	6 ms (default)
11	23.8 ms

When SDZ is released, the device will sample the AD0 and AD1 pins and enter the software shutdown mode.

8.3.11.2 Software Shutdown

Software Shutdown mode powers down all analog blocks required to playback audio, but does not cause the device to lose register state. Software Shutdown is enabled by asserting the *MODE[1:0]* register bits to 2'b10. If audio is playing when Software Shutdown is asserted, the Class-D will volume ramp down before shutting down. When deasserted, the Class-D will begin switching and volume ramp back to the programmed digital volume setting.

8.3.11.3 Mute

The TAS2563 will volume ramp down the Class-D amplifier to a mute state by setting the *MODE[1:0]* register bits to 2'b01. During mute the Class-D still switches, but transmits no audio content. If mute is deasserted, the device will volume ramp back to the programmed digital volume setting.

8.3.11.4 Active

In Active Mode the Class-D switches and plays back audio. Speaker voltage and current sensing are operational if enabled. Set the *MODE[1:0]* register bits to 2'b00 to enter active mode.

8.3.11.5 Perform Load Diagnostics

In Load Diagnostics Mode, TAS2563 checks the speaker terminal for an open or short. This can be used to determine if a problem exists with the speaker or trace to the speaker. The entire operation is performed by the TAS2563 and results reported using the IRQZ pin or read over I²C bus on completion. Set the *MODE[1:0]* register bits to 2'b11 to enter load diagnostics mode.

8.3.11.6 Mode Control and Software Reset

The TAS2563 mode can be configured by writing the *MODE[1:0]* bits.

Table 8-8. Mode Control

<i>MODE[1:0]</i>	SETTING
00	Section 8.3.11.4
01	Section 8.3.11.3
10	Section 8.3.11.2 (default)
11	Section 8.3.11.5

A software reset can be accomplished by asserting the *SW_RESET* bit, which is self clearing. This will restore all registers to their default values.

Table 8-9. Software Reset

<i>SW_RESET</i>	SETTING
0	Don't reset (default)
1	Reset

8.3.12 Faults and Status

During the power-up sequence, the power-on-reset circuit (POR) monitoring the VDD and VBAT pins will hold the device in reset (including all configuration registers) until the supply is valid. The device will not exit hardware shutdown until VDD and VBAT are valid and the SDZ pin is released. Once SDZ is released, the digital core voltage regulator will power up, enabling detection of the operational mode. If VDD dips below the POR threshold, the device will immediately be forced into a reset state.

The device also monitors the VBAT supply and holds the analog core in power down if the supply is below the UVLO threshold. If the TAS2563 is in active operation and a UVLO fault occurs, the analog supplies will immediately power down to protect the device. These faults are latching and require a transition through HW/SW shutdown to clear the fault. The live and latched registers will report UVLO faults.

The device transitions into software shutdown mode if it detects any faults with the TDM clocks such as:

- Invalid SBCLK to FSYNC ratio
- Invalid FSYNC frequency
- Halting of SBCLK or FSYNC clocks

Upon detection of a TDM clock error, the device transitions into software shutdown mode as quickly as possible to limit the possibility of audio artifacts. Once all TDM clock errors are resolved, the device volume ramps back to its previous playback state. During a TDM clock error, the IRQZ pin will assert low if the clock error interrupt mask register bit is set low (*INT_MASK[2]*). The clock fault is also available for readback in the live or latched fault status registers (*INT_LIVE[2]* and *INT_LTCH[2]*). Reading the latched fault status register (*INT_LTCH[7:0]*) clears the register.

The TAS2563 also monitors die temperature and Class-D load current and will enter software shutdown mode if either of these exceed safe values. As with the TDM clock error, the IRQZ pin will assert low for these faults if the appropriate fault interrupt mask register bit is set low (*INT_MASK[0]* for over temp and *INT_MASK[1]* for over current). The fault status can also be monitored in the live and latched fault registers as with the TDM clock error.

Die over temp and Class-D over current errors can either be latching (for example the device will enter software shutdown until a HW/SW shutdown sequence is applied) or they can be configured to automatically retry after a prescribed time. This behavior can be configured in the *OTE_RETRY* and *OCE_RETRY* register bits (for over temp and over current respectively). Even in latched mode, the Class-D will not attempt to retry after an over temp or over current error until the retry time period (1.5 s) has elapsed. This prevents applying repeated stress to the device in a rapid fashion that could lead to device damage. If the device has been cycled through SW/HW shutdown, the device will only begin to operate after the retry time period.

The status registers (and IRQZ pin if enabled via the status mask register) also indicates limiter behavior including when the limiter is activity, when VBAT is below the inflection point, when maximum attenuation has been applied, when the limiter is in infinite hold and when the limiter has muted the audio.

Interrupts can be queried using the *INT_LIVE[9:0]* and *INT_LTCH[13:0]* registers and correspond to the *INT_MASK[10:0]* Interrupts. The latched registers are cleared by writing the self clearing register *INT_CLR_LTCH* high.

The IRQZ pin is an open drain output that asserts low during unmasked fault conditions and therefore must be pulled up with a resistor to IOVDD. An internal pull up resistor is provided in the TAS2563 and can be accessed by setting the *IRQZ_PU* register bit high. [Figure 8-10](#) below highlights the IRQZ pin circuit.

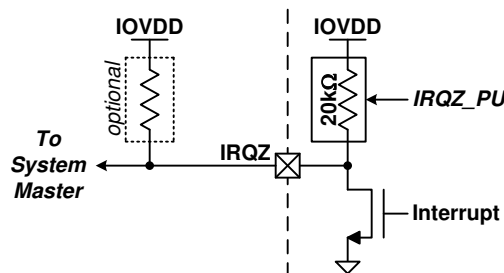

Figure 8-10. IRQZ Pin

Table 8-10. Fault Interrupt Mask

<i>INT_MASK[10:0]</i> BIT	INTERRUPT	DEFAULT (1 = Mask)
0	Over Temp Error	0
1	Over Current Error	0
2	TDM Clock Error	1
3	Limiter Active	1
4	Limter Voltage < Inf Point	1
5	Limiter Max Atten	1
6	Limiter Inf Hold	1
7	Limiter Mute	1

Table 8-10. Fault Interrupt Mask (continued)

<i>INT_MASK[10:0] BIT</i>	INTERRUPT	DEFAULT (1 = Mask)
8	Brown Out on VBAT Supply	0
9	Brown Out Protection Active	1
10	Brown Out Power Down (Latched Only)	1
11:12	Speaker Open Load (Latched Only)	00
13	Load Diagnostic Complete (Latched Only)	1

Table 8-11. IRQ Clear Latched

<i>INT_CLR_LTCH</i>	STATE
0	Don't Clear
1	Clear (self clearing)

Table 8-12. IRQZ Internal Pull Up Enable

<i>IRQZ_PU</i>	STATE
0	Disabled (default)
1	Enabled

Table 8-13. IRQZ Polarity

<i>IRQZ_POL</i>	STATE
0	Active High
1	Active Low (default)

Table 8-14. IRQZ Assert Interrupt Configuration

<i>IRQZ_PIN_CFG[1:0]</i>	VALUE
00	On any unmasked live interrupts
01	On any unmasked latched interrupts (default)
10	For 2-4 ms one time on any unmasked live interrupt event
11	For 2-4 ms every 4 ms on any unmasked latched interrupts

Table 8-15. Retry after Over Current Event

<i>OCE_RETRY</i>	STATE
0	Disabled (default)
1	Enabled

Table 8-16. Retry after Over Temperature Event

<i>OTE_RETRY</i>	VALUE
0	Do not retry (default)
1	Retry after 1.5s

8.3.13 Digital Input Pull Downs

Each digital input and IO has an optional weak pull down to prevent the pin from floating. Pull downs are not enabled during HW shutdown.

Table 8-17. Digital Input Pull Down Enables

REGISTER BIT	DESCRIPTION	BIT VALUE	STATE
<i>DIN_PD[0]</i>	Weak pull down for SBCLK.	0	Disabled (default)
		1	Enabled
<i>DIN_PD[1]</i>	Weak pull down for FSYNC.	0	Disabled (default)
		1	Enabled
<i>DIN_PD[2]</i>	Weak pull down for SDIN.	0	Disabled (default)
		1	Enabled
<i>DIN_PD[3]</i>	Weak pull down for SDOUT.	0	Disabled (default)
		1	Enabled
<i>DIN_PD[4]</i>	Weak pull down forAD0.	0	Disabled (default)
		1	Enabled
<i>DIN_PD[5]</i>	Weak pull down for AD1.	0	Disabled(default)
		1	Enabled
<i>DIN_PD[7]</i>	Weak pull down for GPIO.	0	Disabled
		1	Enabled (default)

8.4 Device Functional Modes

8.4.1 PDM Input

The TAS2563 provides one PDM input. [Figure 8-11](#) below illustrates the double data rate nature of the PDM input. It has two interleaved PDM channels, one sampled by the rising edge and the other by the falling edge of the clock.

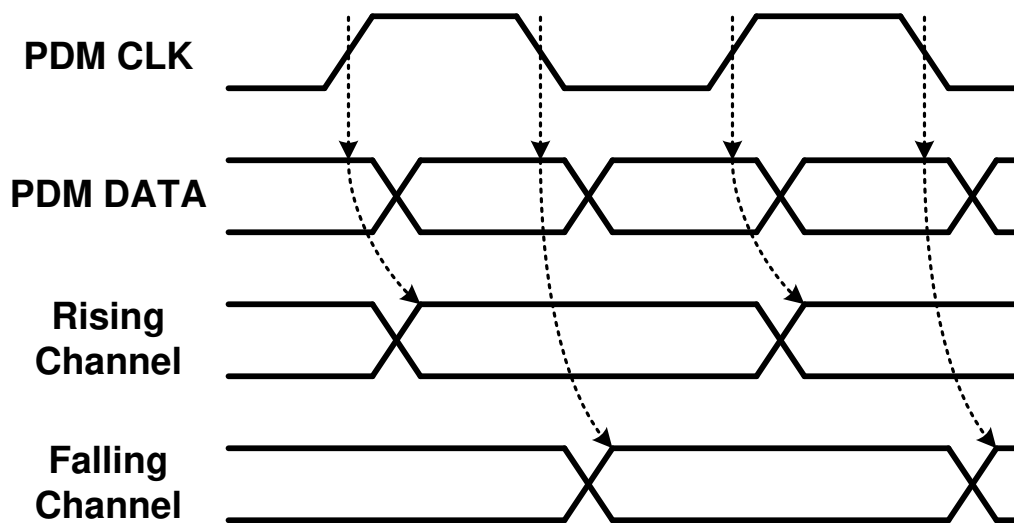

Figure 8-11. PDM Waveform

The PDM inputs are sampled by the PDMCLK pin, which can be configured as either a PDM clock slave input or a PDM clock master output. The *PDM_MIC_EDGE* and *PDM_MIC_SLV* register bits select the sample clock

edge and master/slave mode PDM inputs. In master mode the PDMCLK pin can disable the clocks (and drive a logic 0) by setting the *PDM_GATE_PAD0* register bits low.

When configured as a clock slave, the PDM clock input does not require a specific phase relationship to the system clock (SBCLK in TDM/I²S Mode), but must be from the same source as audio sample rate. This is equivalent to 64/32/16 (~3 MHz) or 128/64/32 (~6 MHz) times a single/double/quadruple speed sample rate. The PDM rate is set by the *PDM_RATE_PAD0*.

When PDMCLK pin is configured as a clock master, the TAS2563 will output a 50% duty cycle clock of frequency that is set by the *PDM_RATE_PAD0* and register bit (64/32/16 or 128/64/32 times a single/double/quadruple speed sample rate).

Table 8-18. PDM Clock Slave

PDM INPUT PIN	REGISTER BIT	VALUE	MASTER/SLAVE
PDMD	<i>PDM_MIC_SLV</i>	0	Master
		1	Slave (default)

Table 8-19. PDM Master Mode Clock Gate

PDM CLOCK PIN	REGISTER BIT	VALUE	GATING
PDMCLK	<i>PDM_GATE_PAD0</i>	1	Gated Off (default)
		0	Active

Table 8-20. PDM Input Sample Rate

PDM INPUT PIN	REGISTER BITS	VALUE	SAMPLE RATE
PDMD	<i>PDM_RATE_PAD0</i>	0	3.072 MHz (default)
		1	6.144 MHz

Table 8-21. PDM MIC Enable

<i>PDM_MIC_EN</i>	MAPPING
<i>PDM_MIC2_EN</i> = 0	Disable MIC2
<i>PDM_MIC2_EN</i> = 1	Enable MIC2
<i>PDM_MIC1_EN</i> = 0	Disable MIC1
<i>PDM_MIC1_EN</i> = 1	Enable MIC1

8.4.2 TDM Port

The TAS2563 provides a flexible TDM serial audio port. The port can be configured to support a variety of formats including stereo I²S, Left Justified and TDM. Mono audio playback is available via the SDIN pin. The SDOOUT pin is used to transmit sample streams including speaker voltage and current sense, VBAT voltage, die temperature and channel gain.

The TDM serial audio port supports up to 16 32-bit time slots at 44.1/48 kHz, 8 32-bit time slots at a 88.2/96 kHz sample rate and 4 32-bit time slots at a 176.4/192 kHz sample rate. The device supports 2 time slots at 32 bits in width and 4 or 8 time slots at 16, 24 or 32 bits in width. Valid SBCLK to FSYNC ratios are 64, 96, 128, 192, 256, 384 and 512. The device will automatically detect the number of time slots and this does not need to be programmed.

By default, the TAS2563 will automatically detect the PCM playback sample rate. This can be disabled by setting the *AUTO_RATE* register bit high and manually configuring the device.

The *SAMP_RATE[2:0]* register bits set the PCM audio sample rate when *AUTO_RATE* is enabled. The TAS2563 employs a robust clock fault detection engine that will automatically volume ramp down the playback path if *FSYNC* does not match the configured sample rate (*AUTO_RATE* enabled) or the ratio of *SBCLK* to *FSYNC* is not supported (minimizing any audible artifacts). Once the clocks are detected to be valid in both frequency and ratio, the device will automatically volume ramp the playback path back to the configured volume and resume playback.

When using the auto rate detection the sampling rate and *SBCLK* to *FSYNC* ratio detected on the TDM bus is reported back on the read-only register *FS_RATE* and *FS_RATIO* respectively.

While the sampling rate of 192 kHz is supported, it is internally down-sampled to 96 kHz. Therefore audio content greater than 40 kHz should not be applied to prevent aliasing. This additionally affects all processing blocks like BOP and limiter which should use 96 kHz fs when accepting 192 kHz audio. It is recommend to use [Section 8.3.1](#) to configure the device.

Table 8-22. PCM Auto Sample Rate Detection

<i>AUTO_RATE</i>	SETTING
0	Enabled (default)
1	Disabled

Table 8-23. PCM Audio Sample Rates

<i>SAMP_RATE[2:0]</i>	<i>FS_RATE</i> (read only)	SAMPLE RATE
000	000	Reserved
001	001	14.7 kHz / 16 kHz
010	010	Reserved
011	011	29.4 kHz / 32 kHz
100	100	44.1 kHz / 48 kHz (default)
101	101	88.2 kHz / 96 kHz
110	110	176.4 kHz / 192 kHz supported only by QFN device package.
111	111	Reserved

Table 8-24. PCM SBCLK to FSYNC Ratio

<i>FS_RATIO[3:0]</i>	SBCLK to FSYNC Ratio
0x0-0x3	Reserved
0x4	64
0x5	96
0x6	128
0x7	192
0x8	256
0x9	384
0xA	512
0xB-0xE	Reserved
0xF	Error Condition

[Figure 8-12](#) and [Figure 8-13](#) below illustrates the receiver frame parameters required to configure the port for playback. A frame begins with the transition of *FSYNC* from either high to low or low to high (set by the

FRAME_START register bit). FSYNC and SDIN are sampled by SBCLK using either the rising or falling edge (set by the RX_EDGE register bit). The RX_OFFSET[4:0] register bits define the number of SBCLK cycles from the transition of FSYNC until the beginning of time slot 0. This is typically set to a value of 0 for Left Justified format and 1 for an I²S format.

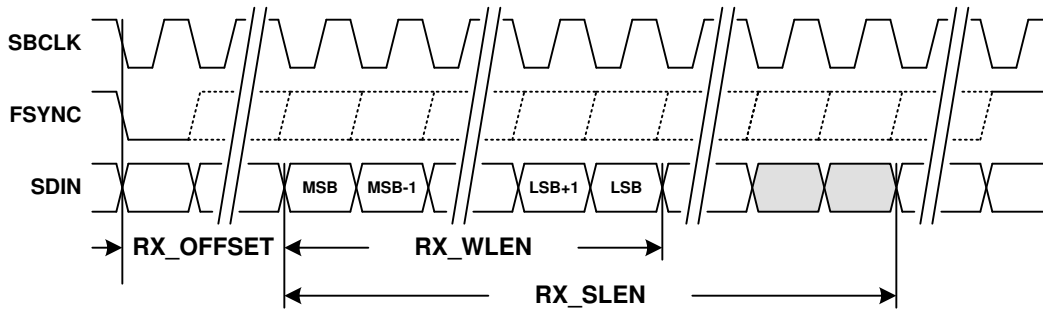

Figure 8-12. TDM RX Time Slot with Left Justification

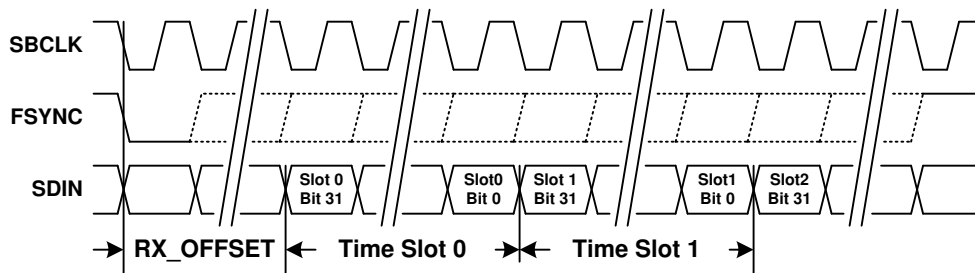

Figure 8-13. TDM RX Time Slots

Table 8-25. TDM Start of Frame Polarity

FRAME_START	POLARITY
0	Low to High on FSYNC ⁽¹⁾
1	High to Low on FSYNC (default) ⁽²⁾

- (1) When Low to High is used RX_EDGE and TX_EDGE cannot both simultaneously be set to rising edge.
- (2) When High to Low is used RX_EDGE and TX_EDGE cannot both simultaneously be set to falling edge.

Table 8-26. TDM RX Capture Polarity

RX_EDGE	FSYNC AND SDIN CAPTURE EDGE
0	Rising edge of SBCLK (default)
1	Falling edge of SBCLK

Table 8-27. TDM RX Start of Frame to Time Slot 0 Offset

RX_OFFSET[4:0]	SBCLK CYCLES
0x00	0
0x01	1 (default)
0x02	2
...	...
0x1E	30

Table 8-27. TDM RX Start of Frame to Time Slot 0 Offset (continued)

<i>RX_OFFSET[4:0]</i>	SBCLK CYCLES
0x1F	31

The *RX_SLEN[1:0]* register bits set the length of the RX time slot. The length of the audio sample word within the time slot is configured by the *RX_WLEN[1:0]* register bits. The RX port will left justify the audio sample within the time slot by default, but this can be changed to right justification via the *RX_JUSTIFY* register bit. The TAS2563 supports mono and stereo down mix playback ($(L+R)/2$) via the left time slot, right time slot and time slot configuration register bits (*RX_SLOT_L[3:0]*, *RX_SLOT_R[3:0]* and *RX_SCFG[1:0]* respectively). By default the device will playback mono from the time slot equal to the I²C base address offset for playback. The *RX_SCFG [1:0]* register bits can be used to override the playback source to the left time slot, right time slot or stereo down mix set by the *RX_SLOT_L[3:0]* and *RX_SLOT_R[3:0]* register bits.

If time slot selections places reception either partially or fully beyond the frame boundary, the receiver will return a null sample equivalent to a digitally muted sample.

Table 8-28. TDM RX Time Slot Length

<i>RX_SLEN[1:0]</i>	TIME SLOT LENGTH
00	16-bits
01	24-bits
10	32-bits (default)
11	reserved

Table 8-29. TDM RX Sample Word Length

<i>RX_WLEN[1:0]</i>	LENGTH
00	16-bits
01	20-bits
10	24-bits (default)
11	32-bits

Table 8-30. TDM RX Sample Justification

<i>RX_JUSTIFY</i>	JUSTIFICATION
0	Left (default)
1	Right

Table 8-31. TDM RX Time Slot Select Configuration

<i>RX_SCFG[1:0]</i>	CONFIG ORIGIN
00	Mono with Time Slot equal to I ² C Address Offset (default)
01	Mono Left Channel
10	Mono Right Channel
11	Stereo Down Mix $(L+R)/2$

Table 8-32. TDM RX Left Channel Time Slot

<i>RX_SLOT_L[3:0]</i>	TIME SLOT
0x0	0 (default)
0x1	1

**Table 8-32. TDM RX Left Channel Time Slot
(continued)**

<i>RX_SLOT_L[3:0]</i>	TIME SLOT
...	...
0xE	14
0xF	15

Table 8-33. TDM RX Right Channel Time Slot

<i>RX_SLOT_R[3:0]</i>	TIME SLOT
0x0	0
0x1	1 (default)
...	...
0xE	14
0xF	15

The TDM port can transmit a number sample streams on the SDOUT pin including speaker voltage sense, speaker current sense, VBAT voltage, die temperature and channel gain. Figure 8-14 below illustrates the alignment of time slots to the beginning of a frame and how a given sample stream is mapped to time slots. Either the rising or falling edge of SBCLK can be used to transmit data on the SDOUT pin, which can be configured by setting the *TX_EDGE* register bit. The *TX_OFFSET* register defines the number SBCLK cycles between the start of a frame and the beginning of time slot 0. This would typically be programmed to 0 for Left Justified format and 1 for I²S format. The TDM TX can either transmit logic 0 or Hi-Z depending on the setting of the *TX_FILL* register bit setting. An optional bus keeper will weakly hold the state of SDOUT when all devices driving are Hi-Z. Since only one bus keeper is required on SDOUT, this feature can be disabled via the *TX_KEEPEEN* register bit. The bus-keeper can additionally be configured to be enabled for only 1LSB cycle or always using *TX_KEEPLN* and to drive the full or half cycle of the LSB using *TX_KEEPCY*.

Each sample stream is composed of either one or two 8-bit time slots. , so they will always utilize two TX time slots. The VBAT voltage stream is 10-bit precision, and can either be transmitted left justified in a 16-bit word (using two time slots) or can be truncated to 8-bits (the top 8 MSBs) and be transmitted in a single time slot. This is configured by setting *VBAT_SLEN* register bit. The Die temperature and gain are both 8-bit precision and are transmitted in a single time slot.

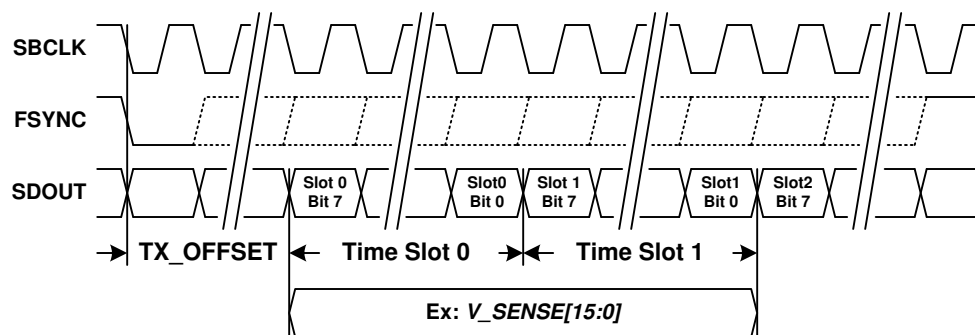

Figure 8-14. TDM Port TX Diagram

Table 8-34. TDM TX Transmit Polarity

<i>TX_EDGE</i>	SDOUT TRANSMIT EDGE
0	Rising edge of SBCLK
1	Falling edge of SBCLK (default)

Table 8-35. TDM TX Start of Frame to Time Slot 0 Offset

<i>TX_OFFSET[2:0]</i>	SBCLK CYCLES
0x0	0
0x1	1 (default)
0x2	2
...	...
0x6	6
0x7	7

Table 8-36. TDM TX Unused Bit Field Fill

<i>TX_FILL</i>	SDOUT UNUSED BIT FIELDS
0	Transmit 0
1	Transmit Hi-Z (default)

Table 8-37. TDM TX SDOUT Bus Keeper Enable

<i>TX_KEEPEM</i>	SDOUT BUS KEEPER
0	Disable bus keeper
1	Enable bus keeper (default)

Table 8-38. TDM TX SDOUT Bus Keeper Length

<i>TX_KEEPLN</i>	SDOUT BUS KEEPER ENABLED FOR
0	1 LSB cycle (default)
1	Always

Table 8-39. TDM TX SDOUT Bus Keeper LSB Cycle

<i>TX_KEEPCY</i>	SDOUT BUS KEEPER DRIVEN
0	full-cycle (default)
1	half-cycle

The time slot register for each sample stream defines where the MSB transmission begins. For instance, if *VSNS_SLOT* is set to 2, the upper 8 MSBs will be transmitted in time slot 2 and the lower 8 LSBs will be transmitted in time slot 3. Each sample stream can be individually enabled or disabled. This is useful to manage limited TDM bandwidth since it may not be necessary to transmit all streams for all devices on the bus.

It is important to ensure that time slot assignments for actively transmitted sample streams do not conflict. For instance, if *VSNS_SLOT* is set to 2 and *ISNS_SLOT* is set to 3, the lower 8 LSBs of voltage sense will conflict with the upper 8 MSBs of current sense. This will produce unpredictable transmission results in the conflicting bit slots (for example the priority is not defined).

The current and voltage values are transmitted at the full 16-bit measured values by default. The *IVMON_LEN* register can be used to transmit only the 8 MSB bits in one slot or 12 MSB bits values across multiple slots. The special 12-bit mode is used when only 24-bit I²S/TDM data can be processed by the host processor. The device should be configured with the voltage-sense slot and current-sense slot off by 1 slot and will consume 3 consecutive 8-bit slots. In this mode the device will transmit the first 12 MSB bits followed by the second 12 MSB bits specified by the preceding slot.

If time slot selections place transmission beyond the frame boundary, the transmitter will truncate transmission at the frame boundary.

It is recommended to keep the following slot ordering:

ISNS_SLOT<VSNS_SLOT<VBAT_SLOT<TEMP_SLOT<GAIN_SLOT<BIL_ILIM_SLOT.

Table 8-40. TDM Voltage/Current Length

<i>IVMON_LEN[1:0]</i>	LENGTH BITS
00	16 bits (default)
01	12 bits
10	8 bits
11	Reserved

Table 8-41. TDM Voltage Sense Time Slot

<i>VSNS_SLOT[5:0]</i>	SLOT
0x00	0
0x01	1
0x02	2 (default)
...	...
0x3E	62
0x3F	63

Table 8-42. TDM Voltage Sense Transmit Enable

<i>VSNS_TX</i>	STATE
0	Disabled (default)
1	Enabled

Table 8-43. TDM Current Sense Time Slot

<i>ISNS_SLOT[5:0]</i>	SLOT
0x00	0 (default)
0x01	1
0x02	2
...	...
0x3E	62
0x3F	63

Table 8-44. TDM Current Sense Transmit Enable

<i>ISNS_TX</i>	STATE
0	Disabled (default)
1	Enabled

Table 8-45. TDM VBAT Time Slot

<i>VBAT_SLOT[5:0]</i>	SLOT
0x00	0
0x01	1
...	...
0x04	4 (default)

Table 8-45. TDM VBAT Time Slot (continued)

<i>VBAT_SLOT[5:0]</i>	SLOT
...	...
0x3E	62
0x3F	63

Table 8-46. TDM VBAT Time Slot Length

<i>VBAT_SLEN</i>	SLOT LENGTH
0	Truncate to 8-bits (default)
1	Left justify to 16-bits

Table 8-47. TDM VBAT Transmit Enable

<i>VBAT_TX</i>	STATE
0	Disabled (default)
1	Enabled

Table 8-48. TDM Temp Sensor Time Slot

<i>TEMP_SLOT[5:0]</i>	SLOT
0x00	0
0x01	1
...	...
0x05	5 (default)
...	...
0x3E	62
0x3F	63

Table 8-49. TDM Temp Sensor Transmit Enable

<i>TEMP_TX</i>	STATE
0	Disabled (default)
1	Enabled

The following sample streams are part of the system. These data streams can be routed over the audio TDM bus .

Table 8-50. TDM Limiter Gain Reduction Time Slot

<i>GAIN_SLOT[5:0]</i>	SLOT
0x00	0
0x01	1
...	...
0x06	6 (default)
...	...
0x3E	62
0x3F	63

Table 8-51. TDM Limiter Gain Reduction Transmit Enable

<i>GAIN_TX</i>	STATE
0	Disabled (default)
1	Enabled

Table 8-52. TDM Boost Sync Time Slot

<i>BST_SLOT[5:0]</i>	SLOT
0x00	0
0x01	1
...	...
0x07	7 (default)
...	...
0x3E	62
0x3F	63

Table 8-53. TDM Boost Sync Enable

<i>BST_TX</i>	STATE
0	Disabled (default)
1	Enabled

Note that the boost sync function is only operational with input sample rates higher than 16 kHz.

8.4.3 Playback Signal Path

8.4.3.1 Digital Signal Processor

An on-chip, low-latency DSP supports Texas Instruments' Smart Amp speaker protection algorithms to maximize loudness while maintaining safe speaker conditions. The DSP implemented in the TAS2563 device offers a variety of algorithm features such as real time tracking, ultrasound and bass processing. Additionally, TAS2563 QFN has a DSP with extra feature such as Smart Bass, Psychoacoustic bass (PBE) and Automatic gain control (AGC).

8.4.3.2 High Pass Filter

Excessive DC and low frequency content in audio playback signal can damage loudspeakers. The TAS2563 employs a high-pass filter (HPF) to prevent this from occurring for the PCM playback path. The HPF can be disabled using register HPF_EN. The HPF Bi-Quad filter coefficients can be changed from the default 2 Hz using the *HPFC_N0*, *HPFC_N1*, *HPFC_D1* registers using the equation $[N, D] = \text{butter}(1, fc/(fs/2), 'high');$; $\text{round}(N(0)*2^{31})$. These coefficients should be calculated and set using [Section 8.3.1](#).

Table 8-54. HPF Enable

<i>HPF_EN</i>	STATE
0	Enabled (default)
1	Disabled

8.4.3.3 Digital Volume Control and Amplifier Output Level

The gain from audio input to speaker terminals is controlled by setting the amplifier's output level and digital volume control (DVC).

Amplifier output level settings are presented in dBV (dB relative to 1 V_{rms}) with a full scale digital audio input (0 dBFS) and the digital volume control set to 0 dB. It should be noted that these levels may not be achievable

because of analog clipping in the amplifier, so they should be used to convey gain only. [Table 8-55](#) below shows gain settings that can be programmed via the *AMP_LEVEL* register.

Table 8-55. Amplifier Output Level Settings

<i>AMP_LEVEL</i> [4:0]	FULL SCALE OUTPUT	
	dBV	V _{PEAK} (V)
0x00	8	3.55
0x01	8.5	3.76
0x02	9	3.99
...
0x10	16	8.92
...
0x13	17.5	10.60
0x14	18	11.23
0x15-0x1F	Reserved	Reserved

[Equation 1](#) calculates the amplifiers output voltage.

$$V_{AMP} = \text{Input} + A_{dvc} + A_{AMP} \text{ dBV} \tag{1}$$

where

- V_{AMP} is the amplifier output voltage in dBV
- Input is the digital input amplitude in dB with respect to 0 dBFS
- A_{dvc} is the digital volume control setting, 0 dB to -100 dB in 0.5 dB steps
- A_{AMP} is the amplifier output level setting in dBV

Settings greater than 0xC8 are interpreted as mute. When a change in digital volume control occurs, the device ramps the volume to the new setting based on the *DVC_RAMP* register bits. If *DVC_RAMP* is set to 0x0000 0000, volume ramping is disabled. This can be used to speed up startup, shutdown and digital volume changes when volume ramping is handled by the system master.

The digital volume control registers *DVC_PCM* represent the volume in a 2.X format. To calculate the value to write to these 4 registers apply the following formula to the desired dB *DVC_PCM* = round(10^(dB/20)*2³⁰).

A volume ramp rate can be set using *DVC_RAMP* and represents a rate in 1.X format. To calculate the value to write to these 4 registers apply the following formula *DVC_RAMP* = round(((1-exp(-1/(0.2*fs*time in seconds))))*2³¹).

Table 8-56. PCM Digital Volume Control

<i>DVC_PCM</i> [31:0]	VOLUME (dB)
0x0000 0D43 (MIN)	-110
...	...
0x4000 0000	0 (default)
...	...
0x5092 BEE4 (MAX)	2

Table 8-57. Digital Volume Ramp Rate

<i>DVC_RAMP</i> [31:0]	RAMP RATE @ 48kHz (s)
0x0000 0D43	0

Table 8-57. Digital Volume Ramp Rate (continued)

<i>DVC_RAMP[31:0]</i>	RAMP RATE @ 48kHz (s)
...	
0x7FFC 963B	1 s

where

- $V_{PK(max,preclip)}$ is the maximum peak unclipped output voltage in V
- V_{BAT} is the power supply voltage
- R_L is the speaker load in Ω
- $R_{interconnect}$ is the additional resistance in the PCB (such as cabling and filters) in Ω
- $R_{FET(on)}$ is the power stage total on resistance (HS FET+LS FET+Sense Resistor+bonding+packaging) in Ω

8.4.3.4 Auto-mute During Idle Channel Mode

Device will stop playing audio if the input audio level drops below the programmable threshold for a programmable timer window. If this behavior is not preferred, threshold level can be kept at very low levels.

8.4.3.5 Auto-start/stop on Audio Clocks

The TAS2563 can enter low power software shutdown when the TDM clocks are stopped instead of going into clock error. The device will resume operation when the clocks resume.

8.4.3.6 Supply Tracking Limiters with Brown Out Prevention

The TAS2563 monitors battery voltage (V_{BAT}) and the class-D voltage ($PVDD$) along with the audio signal to automatically decrease gain when the audio signal peaks exceed a programmable threshold. This helps prevent clipping and extends playback time through end of charge battery conditions. The limiters threshold can be configured to track the monitored voltage below a programmable inflection point with a programmable slope. A minimum threshold sets the limit of threshold reduction from the voltage tracking. Configurable attack rate, hold time and release rate are provided to shape the dynamic response of each limiter. The total attenuation is the sum of both the V_{BAT} and $PVDD$ limiter. If the ICLA is enabled the actual attenuation is based on the ICLA configuration using the calculated attenuation value of all devices on the selected ICLA bus.

A Brown Out Prevention (BOP) feature provides a priority input to provide a very fast response to transient dips in the battery supply (V_{BAT}) which at end of charge conditions that can cause system level brown out. When the selected supply dips below the brown-out threshold the BOP will begin reducing gain with an first attack latency of less than 10 μ s and a configurable attack rate. When the V_{BAT} supply rises above the brownout threshold, the BOP will begin to release after the programmed hold time. During a BOP event the limiter updates will be paused. This is to prevent a limiter from releasing during a BOP event. The V_{BAT} and $PVDD$ limiters are enabled by setting the respective $LIMB_EN$ and $LIMP_EN$ bits high.

Table 8-58. VBAT Tracking Limiter Enable

<i>LIMB_EN</i>	VALUE
0	Disabled (default)
1	Enabled

Table 8-59. PVDD Tracking Limiter Enable

<i>LIMP_EN</i>	VALUE
0	Disabled (default)
1	Enabled

The limiters have configurable attack rates, hold times and release rates, which are available via the $LIMB_ATK_RT[2:0]$, $LIMB_HLD_TM[2:0]$, $LIMB_RLS_RT[2:0]$ register bits respectively for V_{BAT} and $LIMP_ATK_RT[2:0]$, $LIMP_HLD_TM[2:0]$, $LIMP_RLS_RT[2:0]$ register bits respectively for $PVDD$. The limiters attack and release step sizes can be set by configuring the $LIMB_ATK_ST[1:0]$ and $LIMB_RLS_ST[1:0]$ register

bits respectively for VBAT and *LIMP_ATK_ST[1:0]* and *LIMP_RLS_ST[1:0]* register bits respectively for PVDD. For sampling rates less than 44.1kHz and greater than 8 kHz the minimum attack rate is 20µs and for sampling rates of 8kHz or less the minimum attack rate is 40µs.

A maximum level of attenuation applied by the limiters and brown out prevention feature is configurable via the *LIM_MAX_ATN* register. This attenuation limit is shared between the features. For instance, if the maximum attenuation is set to 6 dB and the limiters have reduced gain by 4 dB, the brown out prevention feature will only be able to reduce the gain further by another 2 dB. If the limiter or brown out prevention feature is attacking and it reaches the maximum attenuation, gain will not be reduced any further.

The limiter max attenuation *LIM_MAX_ATN* represent the limit in a 1.X format. To calculate the value to write to the 4 registers by apply the following formula to the desired dB using equation $LIMB_MAX_ATN = \text{round}(10^{(-dB/20)} * 2^{31})$.

Table 8-60. Limiter Max Attenuation

<i>LIM_MAX_ATN[31:0]</i>	ATTENUATION (dB)
0x7214 82C0	-1
...	...
0x2D6A 866F	-9 (default)
...	...
0x1326 DD71	-16.5

The limiter begins reducing gain when the output signal level is greater than the limiter threshold. The limiter can be configured to track selected supply below a programmable inflection point with a minimum threshold value. Figure 8-15 below shows the limiter configured to limit to a constant level regardless of the selected supply level. To achieve this behavior, set the limiter maximum threshold to the desired level using *LIM_TH_MAX*. Set the limiter inflection point using *LIM_INF_PT* below the minimum allowable supply setting. The limiter minimum threshold register *LIM_TH_MIN* does not impact limiter behavior in this use case.

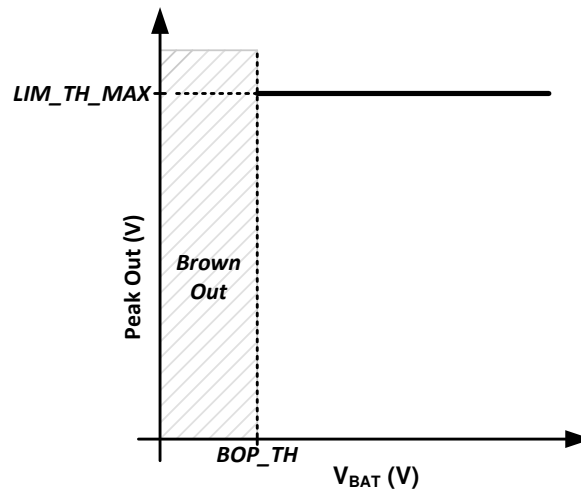

Figure 8-15. Limiter with Fixed Threshold

The VBAT limiter threshold max *LIMB_TH_MAX* and min *LIMB_TH_MIN* registers represent the limit in a 5.X format. To calculate the value to write to the 4 registers by apply the following formula to the desired threshold voltage using the equation $LIMB_TH_MAX$ or $LIMB_TH_MIN = \text{round}(\text{Volts} * 2^{27})$.

Table 8-61. VBAT Limiter Maximum Threshold

<i>LIMB_TH_MAX[31:0]</i>	THRESHOLD (V)
0x1400 0000	2.5

**Table 8-61. VBAT Limiter Maximum Threshold
(continued)**

<i>LIMB_TH_MAX</i> [31:0]	THRESHOLD (V)
...	...
0x4800 0000	9 (default)
...	...
0x7C00 0000	15.5

Table 8-62. VBAT Limiter Minimum Threshold

<i>LIMB_TH_MIN</i> [31:0]	THRESHOLD (V)
0x1400 0000	2.5
...	...
0x2000 0000	4 (default)
...	...
0x7C00 0000	15.5

The VBAT limiter inflection point *LIMB_INF_PT* represent the limit in a 5.X format. To calculate the value to write to the 4 registers by apply the following formula to the desired infection voltage using the equation $LIMB_INF_PT = \text{round}(\text{Volts} \times 2^{27})$.

Table 8-63. VBAT Limiter Inflection Point

<i>LIMB_INF_PT</i> [31:0]	THRESHOLD (V)
0x2000 0000	2
...	...
0x34CC CCCC	3.3 (default)
...	...
0x3000 0000	6

Figure 8-16 shows how to configure the limiter to track selected supply below a threshold without a minimum threshold. Set the *LIM_TH_MAX* register to the desired threshold and *LIM_INF_PT* register to the desired inflection point where the limiter will begin reducing the threshold with the selected supply. The default value of 1 V/V will reduce the threshold 1 V for every 1 V of drop in the supply voltage. More aggressive tracking slopes can be programmed if desired. Program the *LIM_TH_MIN* below the minimum the selected supply to prevent the limiter from having a minimum threshold reduction when tracking the selected supply.

The VBAT limiter tracking slope *LIMB_SLOPE*[31:0] represent the limit in a 5.X format. To calculate the value to write to the 4 registers by apply the following formula to the desired infection voltage using equation $LIMB_SLOPE = \text{round}(\text{slope}(V/V) \times 2^{27})$

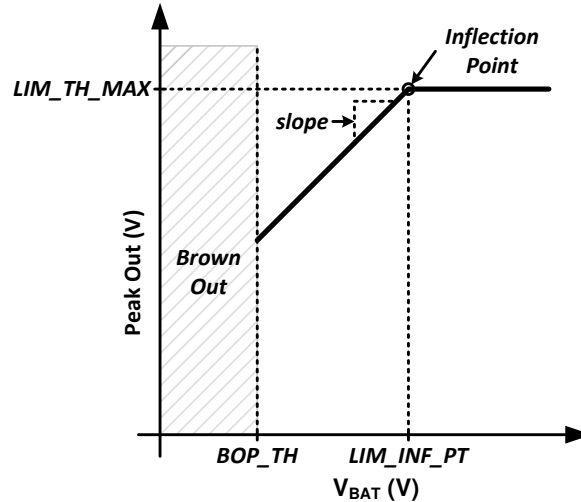

Figure 8-16. Limiter with Inflection Point

To achieve a limiter that tracks the selected supply below a threshold, configure the limiter as explained in the previous example, except program the *LIM_TH_MIN* register to the desired minimum threshold. This is shown in Figure 8-17 below.

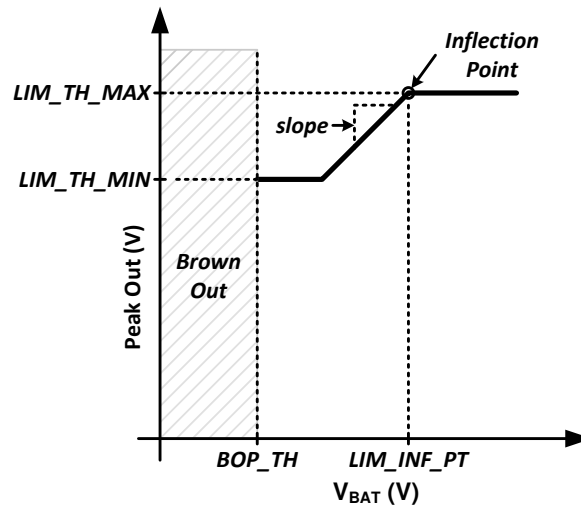

Figure 8-17. Limiter with Inflection Point and Minimum Threshold

The TAS2563 also employs a Brown Out Prevention (BOP) feature that serves as a low latency priority input to the limiter engine that begins attacking the VBAT supply dipping below the programmed BOP threshold. This feature can be enabled by setting the *BOP_EN* register bit high. It should be noted that the BOP feature is independent of the limiter and will function if enabled, even if the limiter is disabled. The BOP threshold is configured by setting the threshold with register bits *BOP_TH*.

Table 8-64. Brown Out Prevention Enable

<i>BOP_EN</i>	VALUE
0	Disabled
1	Enabled (default)

The Brownout prevention threshold *BOP_TH* represent a threshold in a 5.X format. To calculate the value to write to the 4 registers by apply the following formula to the desired brownout threshold using equation $BOP_TH = \text{round}(\text{Volts} * 2^{27})$.

Table 8-65. Brown Out Prevention Threshold

BOP_TH[31:0]	VBAT THRESHOLD (V)
0x0000 000 - 0x1FFF FFFF	Reserved
0x2000 0000	2.5
...	...
0x2E66 6666	2.9 (default)
...	...
0x2000 0000	4
0x2000 0001 - 0xFFFF FFFF	Reserved

The BOP feature has a separate attack rate *BOP_ATK_RT*, attack step size *BOP_ATK_ST* and hold time *BOP_HLD_TM* from the battery tracking limiter. The BOP feature uses the *LIMB_RLS_RT* register setting to release after a brown out event. The rates are based on the number of audio samples and actual time values can be calculated by multiplying by 1/fs. For example the attack rate of 4 samples at 48 ksps would be approximately 83 μ s.

Table 8-66. Brown Out Prevention Attack Rate

BOP_ATK_RT[2:0]	ATTACK RATE (samples/step)	ATTACK RATE @ 48 ksps (~μs)
0x0	1	20
0x1	2	42
0x2	4	83
0x3	8	167
0x4	16	333
0x5	32	666
0x6	64	1300
0x7	128	2700

Table 8-67. Brown Out Prevention Attack Step Size

BOP_ATK_ST[1:0]	STEP SIZE (dB)
00	0.5
01	1 (default)
10	1.5
11	2

Table 8-68. Brown Out Prevention Hold Time

BOP_HLD_TM[2:0]	HOLD TIME (ms)
0x0	0
0x1	10
0x2	25
0x3	50
0x4	100
0x5	250

**Table 8-68. Brown Out Prevention Hold Time
(continued)**

<i>BOP_HLD_TM[2:0]</i>	HOLD TIME (ms)
0x6	500 (default)
0x7	1000

The TAS2563 can also shutdown the device when a brown out event occurs if the *BOP_MUTE* register bit is set high. For the device to continue playing audio again, the device must transition through a SW/HW shutdown state. Setting the *BOP_INF_HLD* high will cause the limiter to stay in the hold state (i.e. never release) after a cleared brown out event until either the device transitions through a mute or SW/HW shutdown state or the register bit *BOP_HLD_CLR* is written to a high value (which will cause the device to exit the hold state and begin releasing). This bit is self clearing and will always readback low. Figure 8-18 below illustrates the entering and exiting from a brown out event.

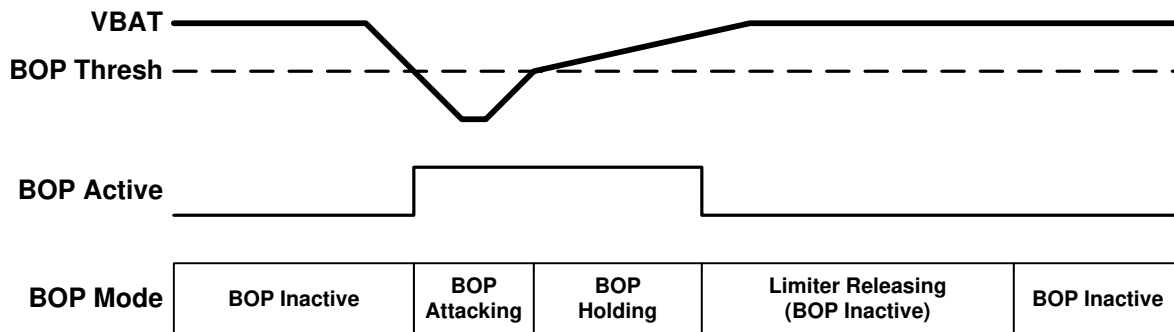

Figure 8-18. Brown Out Prevention Event

Table 8-69. Shutdown on Brown Out Event

<i>BOP_MUTE</i>	VALUE
0	Don't Shutdown (default)
1	Mute then shutdown

Table 8-70. Infinite Hold on Brown Out Event

<i>BOP_INF_HLD</i>	VALUE
0	Use <i>BOP_HLD_TM</i> after Brown Out event (default)
1	Do not release until <i>BOP_HLD_CLR</i> is asserted high

Table 8-71. BOP Infinite Hold Clear

<i>BOP_HLD_CLR</i>	VALUE
0	Don't clear (default)
1	Clear event (self clearing)

A hard brownout level can be set to shutdown the TAS2563 if the BOP cannot mitigate the drop in battery voltage VBAT. This will shutdown the device and should not be used if the *BOP_MUTE* is enable. The brownout shutdown will only function if brownout engine is enabled using *BOP_EN*.

Table 8-72. Brown Out Shutdown Enable

<i>BOSD_EN</i>	VALUE
0	Disabled (default)

Table 8-72. Brown Out Shutdown Enable (continued)

<i>BOSD_EN</i>	VALUE
1	Enabled

The Brownout prevention shutdown threshold *BOSD_TH* represent a threshold in a 5.X format. To calculate the value to write to the 4 registers by apply the following formula to the desired brownout threshold using equation $BOSD_TH = \text{round}(\text{Volts} * 2^{27})$.

Table 8-73. Brown Out Shutdown Threshold

<i>BOSD_TH[31:0]</i>	VBAT THRESHOLD (V)
0x2000 0000	2.5
...	...
0x2B33 3333	2.7 (default)
...	...
0x3FFF FFFF	3.99

8.4.3.7 Class-D Settings

The TAS2563 Class-D amplifier supports spread spectrum PWM modulation, which can be enabled by setting the *AMP_SS* register bit high. This can help reduce EMI in some systems.

Table 8-74. Low EMI Spread Spectrum Mode

<i>AMP_SS</i>	SPREAD SPECTRUM
0	Disabled
1	Enabled (default)

By default the Class-D amplifier's switching frequency is based on the device's trimmed internal oscillator. To synchronize switching to the audio sample rate, set the *CLASSD_SYNC* register bit high. When the Class-D is synchronized to the audio sample rate, the *RATE_RAMP* register bit must be set based whether the audio sample rate is based on a 44.1 kHz or 48 kHz frequency. For 44.1, 88.2 and 176.4 kHz, set this bit high. for 48, 96 and 192 kHz, set this bit low. This ensures that the internal ramp generator has the appropriate slope.

Table 8-75. Class-D Synchronization Mode

<i>CLASSD_SYNC</i>	SYNCHRONIZATION MODE
0	Not synchronized to audio clocks (default)
1	Synchronized to audio clocks

Table 8-76. Sample Rate for Class-D Synchronized Mode

<i>RAMP_RATE</i>	PLAYBACK SAMPLE RATE
0	multiples of 48 kHz (default)
1	multiples of 44.1 kHz

8.4.4 SAR ADC

A 10-bit SAR ADC monitors VBAT voltage *VBAT_CNV*, PVDD voltage *PVDD_CNV* and die temperature *TMP_CNV*. VBAT voltage conversions are also used by the limiter and brown out prevention features.

Actual VBAT voltage is calculated by dividing the *VBAT_CNV* register by 64. Actual die temperature is calculated by subtracting 93 from *TMP_CNV* register. The battery voltage VBAT can be filtered using *VBAT_FLT* register but will increase the latency. The *VBAT_CNV* registers should be read *VBAT_MSB* followed by *VBAT_LSB*.

Table 8-77. ADC VBAT Voltage Conversion

VBAT_CNV[9:0]	VBAT VOLTAGE (V)
0x000	0 V
0x001	0.0156 V
...	...
0x100	4.0 V
...	...
0x17F	5.9844 V
0x180	6.0 V

Table 8-78. ADC Die Temperature Conversion

TMP_CNV[7:0]	DIE TEMPERATURE (°C)
0x00	-93 °C
0x01	-92 °C
...	...
0x76	25 °C
...	...
0xFE	161 °C
0xFF	162 °C

8.4.5 Boost

The TAS2563 internal processing algorithm automatically enables the boost when needed. A look-ahead algorithm monitors the battery voltage and the digital audio stream. When the speaker output approaches the battery voltage the boost is enabled in-time to supply the required speaker output voltage. When the boost is no longer required it is disabled and bypassed to maximize efficiency. The boost can be configured in one of two modes. The first is low in-rush (Class-G) supporting only boost on-off and has the lowest in-rush current. The second is high-efficiency (Class-H) where the boost voltage level is adjusted to a value just above what is needed. This mode is more efficient but has a higher in-rush current to quickly transition the levels. This can be configured using [Table 8-79](#).

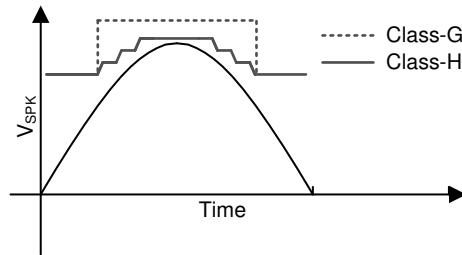

Figure 8-19. Boost Mode Signal Tracking Example

Table 8-79. Boost Mode

BST_MODE[1:0]	BOOST MODE
00	Class-H - High efficiency (default)
01	Class-G - Low in-rush
10	Always On

Table 8-79. Boost Mode (continued)

BST_MODE[1:0]	BOOST MODE
11	Always Off - Pass-through

The boost can be enabled and disabled using *BST_EN* register. When driving the Class-D amplifier using an external supply through the PVDD pin, the boost should be disabled and the VBST pin can be left floating. Do not drive an external voltage on the VBST pin. When supplying an external PVDD voltage the VBAT voltage must also be supplied to the device. While VBAT supply must be present it will not carry current to the speaker load.

Table 8-80. Boost Enable

BST_EN	BOOST IS
0	Disabled
1	Enabled (default)

Table 8-81. Active Mode PFM Lower Frequency Limit

BST_PFML[1:0]	LOWER LIMIT (Hz)
00	No lower limit
01	25 kHz
10	50 kHz (default)
11	100 kHz

The boost has a soft-start to limit in-rush current during the initial charge. The current limit and soft-start timer are configurable to adjust to system component selection.

Table 8-82. Soft-Start Current Limit

BST_SSL[1:0]	CURRENT LIMIT (A)
00	Disabled - Boost Normal Limit
01	1.0 A
10	1.5 A (default)
11	2 A

Table 8-83. Class-G Soft-Start Timer

BST_GSST[1:0]	TIMEOUT (s)
00	1 * BST_HSTT
01	2 * BST_HSTT
10	4 * BST_HSTT (default)
11	8 * BST_HSTT

Table 8-84. Class-H Soft-Start Timer

BST_HSST[3:0]	TIMEOUT (s)
0x0	9 μ S
0x1	18 μ S
0x2	36 μ S
0x3	54 μ S
0x4	72 μ S

Table 8-84. Class-H Soft-Start Timer (continued)

<i>BST_HSST[3:0]</i>	TIMEOUT (s)
0x5	90 μ S
0x6	108 μ S
0x7	135 μ S (default)
0x8	162 μ S
0x9	198 μ S
0xA	252 μ S
0xB	342 μ S
0xC	477 μ S
0xD	612 μ S
0xE	792 μ S
0xF	990 μ S

The boost inductor and decoupling capacitor range needs to be specified using *BST_IR* and *BST_CR* registers. These settings optimize the boost to ensure current limit accuracy and avoid clipping in class-H operation.

Table 8-85. Boost Inductor Range

<i>BST_IR[1:0]</i>	INDUCTANCE (H)
00	< 0.6 μ H
01	0.6 μ H-1.3 μ H (default)
10	1.3 μ H - 2.5 μ H
11	Reserved

Table 8-86. Boost Load Regulation

<i>BST_LR</i>	VALUE
00	Reserved
01	3 A/V; load regulation = 1V (default)
10	2 A/V; load regulation = 1.5 V
11	Reserved

The maximum boost voltage regulation is set by *BST_VREG*. When operating in class-G mode the boost when needed will be at this voltage. In class-H mode of operation the boost voltage is automatically selected based on the audio signal but, will not exceed this set value.

The peak current limits the boost current drawn from the VBAT supply. This setting allows flexibility in the inductor selection for various saturation currents. The current limit can be adjusted in 45 mA steps with register *BST_ILIM[5:0]*. The peak current limit setting is the maximum and may be temporarily reduced if the ICLA current limit is active.

Table 8-87. Peak Current Limit

<i>BST_ILIM[5:0]</i>	CURRENT (A)
0x00	0.99 A
0x01	1.045 A
0x02	1.1 A

Table 8-87. Peak Current Limit (continued)

<i>BST_ILIM[5:0]</i>	CURRENT (A)
...	...
0x36	3.96 A (default)
0x37	4 A
0x38–0x3F	Reserved

For multiple parts the TAS2563 can shift the boost phase to ensure each device will contribute to the load sharing. The boost syncing among multiple devices is enabled using *BST_SYNC* and then each part is configured to be on 0 or 180 phase using *BST_PA*. This avoids peak current align on and clock edges and spreads out battery ripple. The phase of additional devices can be set relative to the master using register *BST_PA[1:0]*. The phase align is performed over the Inter-chip Communication (ICC) bus and a slot for this feature needs to be configured if enabled.

Table 8-88. Boost Sync

<i>BST_SYNC</i>	
0	Not Synced (default)
1	Synced to FSYNC

Table 8-89. Boost Phase

<i>BST_PA[0]</i>	PHASE (Deg)
0	~0° (default)
1	~180°

8.4.6 IV Sense

The TAS2563 provides speaker voltage and current sense for real time monitoring of loudspeaker behavior. The *VSNS_P* and *VSNS_N* pins should be connected after any ferrite bead filter (or directly to the *OUT_P* and *OUT_N* connections if no EMI filter is used). The V-Sense connections eliminate IR drop error due to packaging, PCB interconnect or ferrite bead filter resistance. It should be noted that any interconnect resistance after the V-Sense terminals will not be corrected for, so it is advised to connect the sense connections as close to the load as possible.

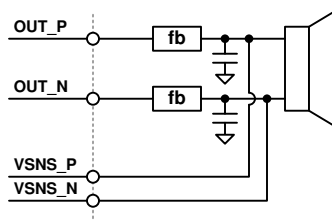
**Figure 8-20. V-Sense Connections**

I-Sense and V-Sense can be powered down by asserting the *ISNS_PD* and *VSNS_PD* register bits respectively. When powered down, the device will return null samples for the powered down block. The IV-sense is High Pass Filtered and the Bi-Quad filter coefficients can be changed from the default 2 Hz using the *IVHPFC_N0*, *IVHPFC_N1*, *IVHPFC_D1* registers using the equations $[N, D] = \text{butter}(1, fc/(fs/2), 'high');$; $\text{round}(N(0)*2^{31});$. These coefficients can be calculated and set using [Section 8.3.1](#).

Table 8-90. I-Sense Power Down

<i>ISNS_PD</i>	SETTING
0	I-Sense is active

Table 8-90. I-Sense Power Down (continued)

ISNS_PD	SETTING
1	I-Sense is powered down (default)

Table 8-91. V-Sense Power Down

VSNS_PD	SETTING
0	V-Sense is active
1	V-Sense is powered down (default)

8.4.7 Load Diagnostics

The TAS2563 can check the speaker terminal for an open or short. This can be used to determine if a problem exists with the speaker or trace to the speaker. The entire operation is performed by the TAS2563 and results reported using the IRQZ pin or read over I²C bus on completion. The load diagnostics can be performed using external audio clock or the internal oscillator.

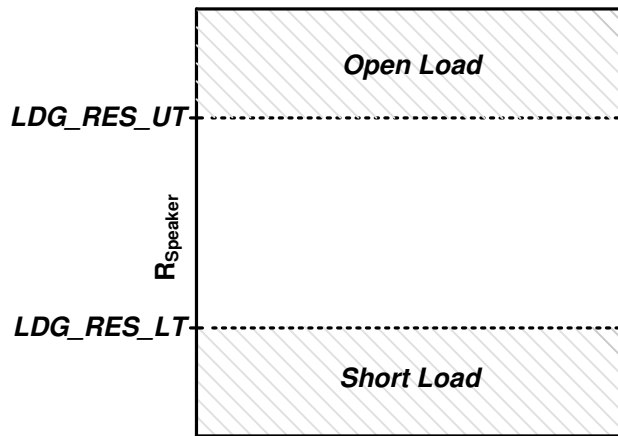

Figure 8-21. Load Diagnostics

The speaker open and short thresholds are configured using the respective LDG_RES_UT and LDG_RES_LT registers using equation $\text{round}(\Omega/7 \cdot 2^{22})$. The load diagnostic mode can be run in two ways. First if the device is in Section 8.3.11.2 the load diagnostic mode can be run by setting LDG_MODE high. The diagnostic will be run and the device will return to Section 8.3.11.2. The load diagnostics can also be run before transitioning to Section 8.3.11.4. This is done by setting the $MODE$ register to Section 8.3.11.5. If the load is within the specified range the device will transition to Section 8.3.11.4 otherwise it will transition to Section 8.3.11.2. When the load diagnostics is run it will play a 22 kHz at -35 dBFS for 100 ms and measure the resistance of the speaker trace. The result is averaged over the time specified by the $IVSNS_AVG$ register. The measured speaker impedance can be read from LDS_RES_VAL1 using the equations $\text{Impedance} = 7 \cdot (LD_RES_VAL1) / 2^{22} \Omega$.

Table 8-92. IV-sense Averaging

IVSNS_AVG[1:0]	SETTING
00	5 ms (default)
01	10 ms
10	50 ms
11	100 ms

Table 8-93. Load Diagnostic Mode

<i>LDG_MODE</i>	SETTING
0	Load Diagnostic Not Running (default)
1	Run Load Diagnostic

Table 8-94. Load Diagnostic Clock Source

<i>LDG_CLK</i>	SETTING
0	External TDM
1	Internal Oscillator (default)

8.4.8 Clocks and PLL

In TDM/I²S Mode, the device operates from SBCLK. [Table 8-95](#) and [Table 8-96](#) below shows the valid SBCLK frequencies for each sample rate and SBCLK to FSYNC ratio (for 44.1 kHz and 48 kHz family frequencies respectively).

If the sample rate is properly configured via the *SAMP_RATE[1:0]* bits, no additional configuration is required as long as the SBCLK to FSYNC ratio is valid. The device will detect improper SBCLK frequencies and SBCLK to FSYNC ratios and volume ramp down the playback path to minimize audible artifacts. After the clock error is detected the device will enter a low power halt mode after *CLK_HALT_TIMER* if *CLK_HALT_EN* is enabled. Additionally the device can automatically power up and down on valid clock signals if *CLK_ERR_PWR_EN* is set. The device sampling rate should not be changed while this feature is enabled. Additionally, the *CLK_HALT_EN* should be set when *CLK_ERR_PWR_EN* is set for this feature to work properly.

Table 8-95. Supported SBCLK Frequencies (48 kHz based sample rates)

Sample Rate (kHz)	SBCLK to FSYNC Ratio						
	64	96	128	192	256	384	512
16 kHz	1.024 MHz	1.536 MHz	2.048 MHz	3.072 MHz	4.096 MHz	6.144 MHz	8.192 MHz
32 kHz	2.048 MHz	3.072 MHz	4.0960 MHz	6.144 MHz	8.192 MHz	12.288 MHz	16.384 MHz
48 kHz	3.072 MHz	4.608 MHz	6.144 MHz	9.216 MHz	12.288 MHz	18.432 MHz	24.576 MHz
96 kHz	6.144 MHz	9.216 MHz	12.288 MHz	18.432 MHz	24.576 MHz	-	-

Table 8-96. Supported SBCLK Frequencies (44.1 kHz based sample rates)

Sample Rate (kHz)	SBCLK to FSYNC Ratio						
	64	96	128	192	256	384	512
14.7 kHz	940.8 kHz	1.4112 MHz	1.8816 MHz	2.8224 MHz	3.7632 MHz	5.6448 MHz	7.5264 MHz
29.4 kHz	1.8816 MHz	2.8224 MHz	3.7632 MHz	5.6448 MHz	7.5264 MHz	11.2896 MHz	15.0528 MHz
44.1 kHz	2.8224 MHz	4.2336 MHz	5.6448 MHz	8.4672 MHz	11.2896 MHz	16.9344 MHz	22.5792 MHz
88.2 kHz	5.6448 MHz	8.4672 MHz	11.2896 MHz	16.9344 MHz	22.5792 MHz	-	-

Table 8-97. Clock Power Up/Down on Valid ASI Clocks

<i>CLK_ERR_PWR_EN</i>	Setting
0	Disabled (default)
1	Enabled

Table 8-98. Clock Halt(Sleep) After Errors Longer Than Halt Timer

<i>CLK_HALT_EN</i>	Setting
0	Enabled (default)

Table 8-98. Clock Halt(Sleep) After Errors Longer Than Halt Timer (continued)

<i>CLK_HALT_EN</i>	Setting
1	Disabled

Table 8-99. Clock Halt Timer

<i>CLK_HALT_TIMER[2:0]</i>	Setting
000	1 ms
001	3.27 ms
010	26.21 ms
011	52.42 ms (default)
100	104.85 ms
101	209.71 ms
110	419.43 ms
111	838.86 ms

8.4.9 Thermal Foldback

The TAS2563 monitors the die temperature and can automatically limit the audio signal when the die temperature reaches a set threshold. It is recommended to use [Section 8.3.1](#) to configure the thermal foldback as the software will perform the necessary math for each register.

Thermal foldback can be disabled using *TF_EN*. If the die temperature reaches *TF_TEMP_TH* this feature will begin to attenuate the audio signal to prevent the device from shutting down due to over-temperature. It will attenuate the audio signal by *TF_LIMS* db per degree of temperature over *TF_TEMP_TH*. The thermal foldback with attack at a fixed rate of 0.25 dB per sample. A maximum attenuation of *TF_MAX_ATTN* can be specified. However if the device continue to heat up eventually the device over-temperature will be triggered. The attenuation will be held for *TF_HOLD_CNT* samples before the attenuation will begin releasing.

Table 8-100. Thermal Foldback Enable

<i>TF_EN</i>	SETTING
0	Disabled
1	Enabled (default)

Table 8-101. Thermal Foldback Registers

REGISTER	DESCRIPTION	CALCULATION
<i>TF_LIMS</i>	Thermal foldback limiter slope (in db/°C)	$\text{round}(10^{-(\text{slope} / 20)} * 2^{31})$
<i>TF_HOLD_CNT</i>	Thermal foldback hold count (samples)	$\text{round}(\text{seconds} * 1000)$
<i>TF_REL_RATE</i>	Thermal foldback limiter release rate (db/samples)	$\text{round}(10^{(\text{dB per sample} / 20)} * 2^{30})$
<i>TF_TEMP_TH</i>	Thermal foldback limiter temperature threshold (°C)	$\text{round}(\text{°C} * 2^{23})$
<i>TF_MAX_ATTN</i>	Thermal foldback max gain reduction (dB)	$\text{round}(10^{(\text{max attn dB} / 20)} * 2^{31})$

8.5 Register Maps

8.5.1 Register Summary Table Page=0x00

Addr	Register	Description	Section
0x00	PAGE	Device Page	Section 8.5.2
0x01	SW_RESET	Software Reset	Section 8.5.3
0x02	PWR_CTL	Power Control	Section 8.5.4
0x03	PB_CFG1	Playback Configuration 1	Section 8.5.5
0x04	MISC_CFG1	Misc Configuration 1	Section 8.5.6
0x05	MISC_CFG2	Misc Configuration 2	Section 8.5.7
0x06	TDM_CFG0	TDM Configuration 0	Section 8.5.8
0x07	TDM_CFG1	TDM Configuration 1	Section 8.5.9
0x08	TDM_CFG2	TDM Configuration 2	Section 8.5.10
0x09	TDM_CFG3	TDM Configuration 3	Section 8.5.11
0x0A	TDM_CFG4	TDM Configuration 4	Section 8.5.12
0x0B	TDM_CFG5	TDM Configuration 5	Section 8.5.13
0x0C	TDM_CFG6	TDM Configuration 6	Section 8.5.14
0x0D	TDM_CFG7	TDM Configuration 7	Section 8.5.15
0x0E	TDM_CFG8	TDM Configuration 8	Section 8.5.16
0x0F	TDM_CFG9	TDM Configuration 9	Section 8.5.17
0x10	TDM_CFG10	TDM Configuration 10	Section 8.5.18
0x11	DSP Mode & TDM_DET	TDM Clock detection monitor	Section 8.5.19
0x12	LIM_CFG0	Limiter Configuration 0	Section 8.5.20
0x13	LIM_CFG1	Limiter Configuration 1	Section 8.5.21
0x14	DSP FREQUENCY & BOP_CFG0	Brown Out Prevention 0	Section 8.5.22
0x15	BOP_CFG0	Brown Out Prevention 2	Section 8.5.23
0x16	BIL_and_ICLA_CFG0	Boost Current limiter and ICLA	Section 8.5.24
0x17	BIL_ICLA_CFG1	Inter Chip Limiter Alignment 0	Section 8.5.25
0x18	GAIN_ICLA_CFG0	Inter Chip Limiter Alignment 0	Section 8.5.26
0x19	ICLA_CFG1	Inter Chip Limiter Alignment 1	Section 8.5.27
0x1A	INT_MASK0	Interrupt Mask 0	Section 8.5.28
0x1B	INT_MASK1	Interrupt Mask 1	Section 8.5.29
0x1C	INT_MASK2	Interrupt Mask 2	Section 8.5.30
0x1D	INT_MASK3	Interrupt Mask 3	Section 8.5.31
0x1F	INT_LIVE0	Live Interrupt Readback 0	Section 8.5.32
0x20	INT_LIVE1	Live Interrupt Readback 1	Section 8.5.33
0x21	INT_LIVE3	Live Interrupt Readback 2	Section 8.5.34
0x22	INT_LIVE4	Live Interrupt Readback 3	Section 8.5.35
0x24	INT_LTCH0	Latched Interrupt Readback 0	Section 8.5.36
0x25	INT_LTCH1	Latched Interrupt Readback 1	Section 8.5.37
0x26	INT_LTCH3	Latched Interrupt Readback 2	Section 8.5.38
0x27	INT_LTCH4	Latched Interrupt Readback 3	Section 8.5.39
0x2A	VBAT_MSB	SAR ADC Conversion 0	Section 8.5.40
0x2B	VBAT_LSB	SAR ADC Conversion 1	Section 8.5.41
0x2C	TEMP	SAR ADC Conversion 2	Section 8.5.42
0x30	INT & CLK CFG		Section 8.5.43
0x31	DIN_PD	Digital Input Pin Pull Down	Section 8.5.44
0x32	MISC	Misc Configuration	Section 8.5.45
0x33	BOOST_CFG1	Boost Configure 1	Section 8.5.46
0x34	BOOST_CFG2	Boost Configure 2	Section 8.5.47
0x35	BOOST_CFG3	Boost Configure 3	Section 8.5.48

0x3B	MISC		Section 8.5.49
0x3F	TG_CFG0	Tone Generator	Section 8.5.50
0x40	BST_ILIM_CFG0	Boost ILIM configuration-0	Section 8.5.51
0x41	PDM_CONFIG0		Section 8.5.52
0x42	DIN_PD & PDM_CONFIG3		Section 8.5.53
0x43	ASI2_CONFIG0		Section 8.5.54
0x44	ASI2_CONFIG1		Section 8.5.55
0x45	ASI2_CONFIG2		Section 8.5.56
0x46	ASI2_CONFIG3		Section 8.5.57
0x49	PVDD_MSB_DSP	SAR ADC Conversion 0	Section 8.5.58
0x4A	PVDD_LSB_DSP	SAR ADC Conversion 1	Section 8.5.59
0x7D	REV_ID	Revision and PG ID	Section 8.5.60
0x7E	I2C_CKSUM	I2C Checksum	Section 8.5.61
0x7F	BOOK	Device Book	Section 8.5.62

8.5.2 PAGE (page=0x00 address=0x00) [reset=0h]

The device's memory map is divided into pages and books. This register sets the page.

Figure 8-22. PAGE Register Address: 0x00

7	6	5	4	3	2	1	0
PAGE[7:0]							
RW-0h							

LEGEND: R/W = Read/Write; R = Read only; -n = value after reset

Table 8-102. Device Page Field Descriptions

Bit	Field	Type	Reset	Description
7-0	PAGE[7:0]	RW	0h	Sets the device page. 00h = Page 0 01h = Page 1 ... FFh = Page 255

8.5.3 SW_RESET (page=0x00 address=0x01) [reset=0h]

Asserting Software Reset will place all register values in their default POR (Power on Reset) state.

Figure 8-23. SW_RESET Register Address: 0x01

7	6	5	4	3	2	1	0
Reserved							SW_RESET
R-0h							RW-0h

LEGEND: R/W = Read/Write; R = Read only; -n = value after reset

Table 8-103. Software Reset Field Descriptions

Bit	Field	Type	Reset	Description
7-1	Reserved	R	0h	Reserved
0	SW_RESET	RW	0h	Software reset. Bit is self clearing. 0b = Don't reset 1b = Reset

8.5.4 PWR_CTL (page=0x00 address=0x02) [reset=Eh]

Sets device's mode of operation and power down of IV sense blocks.

Figure 8-24. PWR_CTL Register Address: 0x02

7	6	5	4	3	2	1	0
PDM_I2S_MODE E	LDG_MODE_O NLY	Reserved	Reserved	ISNS_PD	VSNS_PD	MODE[1:0]	
RW-0h	RW-0h	RW-0h	RW-0h	RW-1h	RW-1h	RW-2h	

LEGEND: R/W = Read/Write; R = Read only; -n = value after reset

Table 8-104. Power Control Field Descriptions

Bit	Field	Type	Reset	Description
7	PDM_I2S_MODE	RW	0h	PDM I2S mode 0b = PDM_I2S mode disabled 1b = PDM_I2S mode enabled
6	LDG_MODE_ONLY	RW	0h	Only Load Diagnostics mode, self clearing bit 0b = Only Load diagnostics mode disabled 1b = Only Load diagnostics mode enabled
5	Reserved	RW	0h	Reserved
4	Reserved	RW	0h	Reserved
3	ISNS_PD	RW	1h	Current sense power down. 0b = Current sense active 1b = Current sense is powered down
2	VSNS_PD	RW	1h	Voltage sense power down. 0b = voltage sense is active 1b = Voltage sense is powered down
1-0	MODE[1:0]	RW	2h	Device operational mode. 00b = Active 01b = Mute 10b = Software Shutdown 11b = Load Diagnostics followed by device ACTIVE

8.5.5 PB_CFG1 (page=0x00 address=0x03) [reset=20h]

Sets playback high pass filter corner (PCM playback only).

Figure 8-25. PB_CFG1 Register Address: 0x03

7	6	5	4	3	2	1	0
Reserved	DIS_DC_BLOCK KER	AMP_LEVEL[4:0]					Reserved
R-0h	RW-0h	RW-10h					RW-0h

LEGEND: R/W = Read/Write; R = Read only; -n = value after reset

Table 8-105. Playback Configuration 1 Field Descriptions

Bit	Field	Type	Reset	Description
7	Reserved	R	0h	Reserved
6	DIS_DC_BLOCKER	RW	0h	Disable DC Blocker 0b = DC Blocker Enabled 1b = DC Blocker Disabled

Table 8-105. Playback Configuration 1 Field Descriptions (continued)

Bit	Field	Type	Reset	Description
5-1	AMP_LEVEL[4:0]	RW	10h	1Dh-1Fh - Reserved 01h = 8.5 dBV(3.76Vpk) 02h = 9.0 dBV(3.99Vpk) 03h = 9.5 dBV(4.22Vpk) 04h = 10.0 dBV(4.47Vpk) 05h = 10.5 dBV(4.74Vpk) 06h = 11.0 dBV (5.02 Vpk) 07h = 11.5 dBV (5.32 Vpk) 08h = 12.0 dBV (5.63 Vpk) 09h = 12.5 dBV (5.96 Vpk) 0Ah = 13.0 dBV (6.32 Vpk) 0Bh = 13.5 dBV (6.69 Vpk) 0Ch = 14.0 dBV (7.09 Vpk) 0Dh = 14.5 dBV (7.51 Vpk) 0Eh = 15.0 dBV (7.95 Vpk) 0Fh = 15.5 dBV (8.42 Vpk) 10h = 16.0 dBV (8.92 Vpk) 11h = 16.5 dBV (9.45 Vpk) 12h = 17.0 dBV (10.01 Vpk) 13h = 17.5 dBV (10.61 Vpk) 14h = 18.0 dBV (11.23 Vpk) 15h = 18.5dBV(11.90 Vpk) 16h = 19dBV(12.60Vpk) 17h = 19.5dBV(13.35Vpk) 18h = 20.0dBV(14.14Vpk) 19h = 20.5dBV(14.98Vpk) 1Ah = 21dBV(15.87Vpk) 1Bh = 21.5dBV(16.81Vpk) 1Ch = 22dBV(17.8Vpk) 1Dh-1Fh - Reserved
0	Reserved	RW	0h	Reserved

8.5.6 MISC_CFG1 (page=0x00 address=0x04) [reset=C6h]

Sets DVC Ramp Rate, OTE/OCE retry, IRQZ pull up, amp spread spectrum and I-Sense current range.

Figure 8-26. MISC_CFG1 Register Address: 0x04

7	6	5	4	3	2	1	0
CP_PG_RETR Y	VBAT_POR_RE TRY	OCE_RETRY	OTE_RETRY	IRQZ_PU	AMP_SS	Reserved	
RW-1h	RW-1h	RW-0h	RW-0h	RW-0h	RW-1h	RW-2h	

LEGEND: R/W = Read/Write; R = Read only; -n = value after reset

Table 8-106. Misc Configuration 1 Field Descriptions

Bit	Field	Type	Reset	Description
7	CP_PG_RETRY	RW	1h	Retry after vbat por event. 0b = Do not retry 1b = Retry after 1.5 s
6	VBAT_POR_RETRY	RW	1h	Retry after vbat por event. 0b = Do not retry 1b = Retry after 1.5 s
5	OCE_RETRY	RW	0h	Retry after over current event. 0b = Do not retry 1b = Retry after 1.5 s
4	OTE_RETRY	RW	0h	Retry after over temperature event. 0b = Do not retry 1b = Retry after 1.5 s

Table 8-106. Misc Configuration 1 Field Descriptions (continued)

Bit	Field	Type	Reset	Description
3	IRQZ_PU	RW	0h	IRQZ internal pull up enable. 0b = Disabled 1b = Enabled
2	AMP_SS	RW	1h	Low EMI spread spectrum enable. 0b = Disabled 1b = Enabled
1-0	Reserved	RW	2h	Reserved

8.5.7 MISC_CFG2 (page=0x00 address=0x05) [reset=22h]**Figure 8-27. MISC_CFG2 Register Address: 0x05**

7	6	5	4	3	2	1	0
SDZ_MODE[1:0]		SDZ_TIMEOUT[1:0]		Reserved	DIS_VBAT_FLT	I2C_GBL_EN	DIS_PVDD_FLT
RW-0h		RW-2h		RW-0h	RW-0h	RW-1h	RW-0h

LEGEND: R/W = Read/Write; R = Read only; -n = value after reset

Table 8-107. Misc Configuration 2 Field Descriptions

Bit	Field	Type	Reset	Description
7-6	SDZ_MODE[1:0]	RW	0h	SDZ Mode configuration. 00b = initiates normal shutdown; force shutdown after timeout 01b = immediate force shutdown 10b = normal shutdown only 11b = reserved
5-4	SDZ_TIMEOUT[1:0]	RW	2h	SDZ Timeout value 00b = 2 ms 01b = 4 ms 10b = 6 ms 11b = 23.8 ms
3	Reserved	RW	0h	Reserved
2	DIS_VBAT_FLT	RW	0h	VBAT filter into SAR ADC 0b = VBAT filter with 100kHz cut off 1b = Bypass VBAT FLT
1	I2C_GBL_EN	RW	1h	I2C global address is 0b = disabled 1b = enabled
0	DIS_PVDD_FLT	RW	0h	PVDD filter into SAR ADC 0b = PVDD filter with 100kHz cut off 1b = Bypass PVDD FLT

8.5.8 TDM_CFG0 (page=0x00 address=0x06) [reset=9h]

Sets the TDM frame start, TDM sample rate, TDM auto rate detection and whether rate is based on 44.1 kHz or 48 kHz frequency.

Figure 8-28. TDM_CFG0 Register Address: 0x06

7	6	5	4	3	2	1	0
Reserved	CLASSD_SYNC	RAMP_RATE	AUTO_RATE	SAMP_RATE[2:0]		FRAME_START	
R-0h	RW-0h	RW-0h	RW-0h	RW-4h		RW-1h	

LEGEND: R/W = Read/Write; R = Read only; -n = value after reset

Table 8-108. TDM Configuration 0 Field Descriptions

Bit	Field	Type	Reset	Description
7	Reserved	R	0h	Reserved
6	CLASSD_SYNC	RW	0h	Class-D synchronization mode. 0b = Not synchronized to audio clocks 1b = Synchronized to audio clocks
5	RAMP_RATE	RW	0h	Sample rate based on 44.1kHz or 48kHz when CLASSD_SYNC=1. 0b = 48kHz 1b = 44.1kHz
4	AUTO_RATE	RW	0h	Auto detection of TDM sample rate. 0b = Enabled 1b = Disabled
3-1	SAMP_RATE[2:0]	RW	4h	Sample rate of the TDM bus. 000b = 7.35/8 kHz 001b = 14.7/16 kHz 010b = 22.05/24 kHz 011b = 29.4/32 kHz 100b = 44.1/48 kHz 101b = 88.2/96 kHz 110b = 176.4/192 kHz 111b = Reserved
0	FRAME_START	RW	1h	TDM frame start polarity. 0b = Low to High on FSYNC 1b = High to Low on FSYNC

8.5.9 TDM_CFG1 (page=0x00 address=0x07) [reset=2h]

Sets TDM RX justification, offset and capture edge.

Figure 8-29. TDM_CFG1 Register Address: 0x07

7	6	5	4	3	2	1	0
Reserved	RX_JUSTIFY	RX_OFFSET[4:0]					RX_EDGE
R-0h	RW-0h	RW-1h					RW-0h

LEGEND: R/W = Read/Write; R = Read only; -n = value after reset

Table 8-109. TDM Configuration 1 Field Descriptions

Bit	Field	Type	Reset	Description
7	Reserved	R	0h	Reserved
6	RX_JUSTIFY	RW	0h	TDM RX sample justification within the time slot. 0b = Left 1b = Right
5-1	RX_OFFSET[4:0]	RW	1h	TDM RX start of frame to time slot 0 offset (SBCLK cycles).
0	RX_EDGE	RW	0h	TDM RX capture clock polarity. 0b = Rising edge of SBCLK 1b = Falling edge of SBCLK

8.5.10 TDM_CFG2 (page=0x00 address=0x08) [reset=4Ah]

Sets TDM RX time slot select, word length and time slot length.

Figure 8-30. TDM_CFG2 Register Address: 0x08

7	6	5	4	3	2	1	0
IVMON_LEN[1:0]		RX_SCFG[1:0]		RX_WLEN[1:0]		RX_SLEN[1:0]	
RW-1h		RW-0h		RW-2h		RW-2h	

LEGEND: R/W = Read/Write; R = Read only; -n = value after reset

Table 8-110. TDM Configuration 2 Field Descriptions

Bit	Field	Type	Reset	Description
7-6	IVMON_LEN[1:0]	RW	1h	Sets the current and voltage data to length of 00b = 8 bits 01b = 16 bits 10b = 24 bits 11b = 32 bits
5-4	RX_SCFG[1:0]	RW	0h	TDM RX time slot select config. 00b = Mono with time slot equal to I2C address offset 01b = Mono left channel 10b = Mono right channel 11b = Stereo downmix (L+R)/2
3-2	RX_WLEN[1:0]	RW	2h	TDM RX word length. 00b = 16-bits 01b = 20-bits 10b = 24-bits 11b = 32-bits
1-0	RX_SLEN[1:0]	RW	2h	TDM RX time slot length. 00b = 16-bits 01b = 24-bits 10b = 32-bits 11b = Reserved

8.5.11 TDM_CFG3 (page=0x00 address=0x09) [reset=10h]

Sets TDM RX left and right time slots.

Figure 8-31. TDM_CFG3 Register Address: 0x09

7	6	5	4	3	2	1	0
RX_SLOT_R[3:0]				RX_SLOT_L[3:0]			
RW-1h				RW-0h			

LEGEND: R/W = Read/Write; R = Read only; -n = value after reset

Table 8-111. TDM Configuration 3 Field Descriptions

Bit	Field	Type	Reset	Description
7-4	RX_SLOT_R[3:0]	RW	1h	TDM RX Right Channel Time Slot.
3-0	RX_SLOT_L[3:0]	RW	0h	TDM RX Left Channel Time Slot.

8.5.12 TDM_CFG4 (page=0x00 address=0x0A) [reset=13h]

Sets TDM TX bus keeper, fill, offset and transmit edge.

Figure 8-32. TDM_CFG4 Register Address: 0x0A

7	6	5	4	3	2	1	0
TX_KEEPCY	TX_KEEPLN	TX_KEEPEN	TX_FILL	TX_OFFSET[2:0]		TX_EDGE	
RW-0h	RW-0h	RW-0h	RW-1h	RW-1h		RW-1h	

LEGEND: R/W = Read/Write; R = Read only; -n = value after reset

Table 8-112. TDM Configuration 4 Field Descriptions

Bit	Field	Type	Reset	Description
7	TX_KEEPCY	RW	0h	TDM TX SDOOUT LSB data will be driven for 0b = full-cycle 1b = half-cycle
6	TX_KEEPLN	RW	0h	TDM TX SDOOUT will hold the bus for the following when TX_KEEPEN is enabled 0b = 1 LSB cycle 1b = always

Table 8-112. TDM Configuration 4 Field Descriptions (continued)

Bit	Field	Type	Reset	Description
5	TX_KEEPEN	RW	0h	TDM TX SDOUT bus keeper enable. 0b = Disable bus keeper 1b = Enable bus keeper
4	TX_FILL	RW	1h	TDM TX SDOUT unused bitfield fill. 0b = Transmit 0 1b = Transmit Hi-Z
3-1	TX_OFFSET[2:0]	RW	1h	TDM TX start of frame to time slot 0 offset.
0	TX_EDGE	RW	1h	TDM TX launch clock polarity. 0b = Rising edge of SBCLK 1b = Falling edge of SBCLK

8.5.13 TDM_CFG5 (page=0x00 address=0x0B) [reset=2h]

Sets TDM TX V-Sense time slot and enable.

Figure 8-33. TDM_CFG5 Register Address: 0x0B

7	6	5	4	3	2	1	0
Reserved	VSNS_TX	VSNS_SLOT[5:0]					
R-0h	RW-0h	RW-2h					

LEGEND: R/W = Read/Write; R = Read only; -n = value after reset

Table 8-113. TDM Configuration 5 Field Descriptions

Bit	Field	Type	Reset	Description
7	Reserved	R	0h	Reserved
6	VSNS_TX	RW	0h	TDM TX voltage sense transmit enable. 0b = Disabled 1b = Enabled
5-0	VSNS_SLOT[5:0]	RW	2h	TDM TX voltage sense time slot.

8.5.14 TDM_CFG6 (page=0x00 address=0x0C) [reset=0h]

Sets TDM TX I-Sense time slot and enable.

Figure 8-34. TDM_CFG6 Register Address: 0x0C

7	6	5	4	3	2	1	0
Reserved	ISNS_TX	ISNS_SLOT[5:0]					
R-0h	RW-0h	RW-0h					

LEGEND: R/W = Read/Write; R = Read only; -n = value after reset

Table 8-114. TDM Configuration 6 Field Descriptions

Bit	Field	Type	Reset	Description
7	Reserved	R	0h	Reserved
6	ISNS_TX	RW	0h	TDM TX current sense transmit enable. 0b = Disabled 1b = Enabled
5-0	ISNS_SLOT[5:0]	RW	0h	TDM TX current sense time slot.

8.5.15 TDM_CFG7 (page=0x00 address=0x0D) [reset=4h]

Sets TDM TX VBAT time slot and enable.

Figure 8-35. TDM_CFG7 Register Address: 0x0D

7	6	5	4	3	2	1	0
---	---	---	---	---	---	---	---

Figure 8-35. TDM_CFG7 Register Address: 0x0D (continued)

VBAT_SLEN	VBAT_TX	VBAT_SLOT[5:0]
RW-0h	RW-0h	RW-4h

LEGEND: R/W = Read/Write; R = Read only; -n = value after reset

Table 8-115. TDM Configuration 7 Field Descriptions

Bit	Field	Type	Reset	Description
7	VBAT_SLEN	RW	0h	TDM TX VBAT time slot length. 0b = Truncate to 8-bits 1b = Left justify to 16-bits
6	VBAT_TX	RW	0h	TDM TX VBAT transmit enable. 0b = Disabled 1b = Enabled
5-0	VBAT_SLOT[5:0]	RW	4h	TDM TX VBAT time slot.

8.5.16 TDM_CFG8 (page=0x00 address=0x0E) [reset=5h]

Sets TDM TX temp time slot and enable.

Figure 8-36. TDM_CFG8 Register Address: 0x0E

7	6	5	4	3	2	1	0
Reserved	TEMP_TX	TEMP_SLOT[5:0]					
R-0h	RW-0h	RW-5h					

LEGEND: R/W = Read/Write; R = Read only; -n = value after reset

Table 8-116. TDM Configuration 8 Field Descriptions

Bit	Field	Type	Reset	Description
7	Reserved	R	0h	Reserved
6	TEMP_TX	RW	0h	TDM TX temp sensor transmit enable. 0b = Disabled 1b = Enabled
5-0	TEMP_SLOT[5:0]	RW	5h	TDM TX temp sensor time slot.

8.5.17 TDM_CFG9 (page=0x00 address=0x0F) [reset=6h]

Sets ICLA bus, TDM TX limiter gain reduction time slot and enable.

Figure 8-37. TDM_CFG9 Register Address: 0x0F

7	6	5	4	3	2	1	0
Reserved	GAIN_TX	GAIN_SLOT[5:0]					
R-0h	RW-0h	RW-6h					

LEGEND: R/W = Read/Write; R = Read only; -n = value after reset

Table 8-117. TDM Configuration 9 Field Descriptions

Bit	Field	Type	Reset	Description
7	Reserved	R	0h	Reserved
6	GAIN_TX	RW	0h	TDM TX limiter gain reduction transmit enable. 0b = Disabled 1b = Enabled
5-0	GAIN_SLOT[5:0]	RW	6h	TDM TX limiter gain reduction time slot.

8.5.18 TDM_CFG10 (page=0x00 address=0x10) [reset=7h]

Sets boost current limiter slot and enable

Figure 8-38. TDM_CFG10 Register Address: 0x10

7	6	5	4	3	2	1	0
BST_TX	BST_SYNC_TX	BST_SLOT[5:0]					
RW-0h	RW-0h	RW-7h					

LEGEND: R/W = Read/Write; R = Read only; -n = value after reset

Table 8-118. TDM Configuration 10 Field Descriptions

Bit	Field	Type	Reset	Description
7	BST_TX	RW	0h	TDM TX boost current limiter enable. 0b = Disabled 1b = Enabled
6	BST_SYNC_TX	RW	0h	TDM TX boost clock sync enable. 0b = Disabled 1b = Enabled
5-0	BST_SLOT[5:0]	RW	7h	TDM TX boost sync and current limit time slot.

8.5.19 DSP Mode & TDM_DET (page=0x00 address=0x11) [reset=7Fh]

Readback of internal auto-rate detection.

Figure 8-39. DSP Mode & TDM_DET Register Address: 0x11

7	6	5	4	3	2	1	0
Reserved	FS_RATIO[3:0]				FS_RATE[2:0]		
R-0h	R-Fh				R-7h		

LEGEND: R/W = Read/Write; R = Read only; -n = value after reset

Table 8-119. TDM Clock detection monitor Field Descriptions

Bit	Field	Type	Reset	Description
7	Reserved	R	0h	Reserved
6-3	FS_RATIO[3:0]	R	Fh	Detected SBCLK to FSYNC ratio. 00h = 16 01h = 24 02h = 32 03h = 48 04h = 64 05h = 96 06h = 128 07h = 192 08h = 256 09h = 384 0Ah = 512 0Bh-0Eh = Reserved 0F = Invalid ratio
2-0	FS_RATE[2:0]	R	7h	Detected sample rate of TDM bus. 000b = 7.35/8 KHz 001b = 14.7/16 KHz 010b = 22.05/24 KHz 011b = 29.4/32 KHz 100b = 44.1/48 KHz 101b = 88.2/96 KHz 110b = 176.4/192 KHz 111b = Error condition

8.5.20 LIM_CFG0 (page=0x00 address=0x12) [reset=12h]

Sets Limiter attack step size, attack rate and enable.

Figure 8-40. LIM_CFG0 Register Address: 0x12

7	6	5	4	3	2	1	0
Reserved	VBAT_LIM_TH_SELECTION	LIMB_ATK_ST[1:0]		LIMB_ATK_RT[2:0]			LIMB_EN
R-0h	RW-0h	RW-1h		RW-1h			RW-0h

LEGEND: R/W = Read/Write; R = Read only; -n = value after reset

Table 8-120. Limiter Configuration 0 Field Descriptions

Bit	Field	Type	Reset	Description
7	Reserved	R	0h	Reserved
6	VBAT_LIM_TH_SELECTION	RW	0h	Select source of threshold for VBAT based limiting 0b = User configured Thresholds 1b = PVDD based thresholds
5-4	LIMB_ATK_ST[1:0]	RW	1h	VBAT Limiter attack step size. 00b = 0.25 dB 01b = 0.5 dB 10b = 1 dB 11b = 2 dB
3-1	LIMB_ATK_RT[2:0]	RW	1h	VBAT Limiter attack rate. 000b = 1 step in 1 sample 001b = 1 step in 2 samples 010b = 1 step in 4 samples 011b = 1 step in 8 samples 100b = 1 step in 16 samples 101b = 1 step in 32 samples 110b = 1 step in 64 samples 111b = 1 step in 128 samples
0	LIMB_EN	RW	0h	Limiter enable. 0b = Disabled 1b = Enabled

8.5.21 LIM_CFG1 (page=0x00 address=0x13) [reset=76h]

Sets VBAT limiter release step size, release rate and hold time.

Figure 8-41. LIM_CFG1 Register Address: 0x13

7	6	5	4	3	2	1	0
LIMB_RLS_ST[1:0]		LIMB_RLS_RT[2:0]			LIMB_HLD_TM[2:0]		
RW-1h		RW-6h			RW-6h		

LEGEND: R/W = Read/Write; R = Read only; -n = value after reset

Table 8-121. Limiter Configuration 1 Field Descriptions

Bit	Field	Type	Reset	Description
7-6	LIMB_RLS_ST[1:0]	RW	1h	VBAT Limiter/BOP/ICLA release step size. 00b = 0.25 dB 01b = 0.5 dB 10b = 1 dB 11b = 2 dB
5-3	LIMB_RLS_RT[2:0]	RW	6h	VBAT Limiter/BOP/ICLA release rate. 000b = 1 step in 10 ms 001b = 1 step in 20 ms 010b = 1 step in 40 ms 011b = 1 step in 80 ms 100b = 1 step in 160 ms 101b = 1 step in 320 ms 110b = 1 step in 640 ms 111b = 1 step in 1280 ms

Table 8-121. Limiter Configuration 1 Field Descriptions (continued)

Bit	Field	Type	Reset	Description
2-0	LIMB_HLD_TM[2:0]	RW	6h	VBAT Limiter hold time. 000b = 0 ms 001b = 10 ms 010b = 25 ms 011b = 50 ms 100b = 100 ms 101b = 250 ms 110b = 500 ms 111b = 1000 ms

8.5.22 DSP FREQUENCY & BOP_CFG0 (page=0x00 address=0x14) [reset=1h]

Sets BOP infinite hold clear, infinite hold enable, mute on brown out and enable.

Figure 8-42. DSP FREQUENCY & BOP_CFG0 Register Address: 0x14

7	6	5	4	3	2	1	0
Reserved			BOSD_EN	BOP_HLD_CLR	BOP_INF_HLD	BOP_MUTE	BOP_EN
R-0h			RW-0h	RW-0h	RW-0h	RW-0h	RW-1h

LEGEND: R/W = Read/Write; R = Read only; -n = value after reset

Table 8-122. Brown Out Prevention 0 Field Descriptions

Bit	Field	Type	Reset	Description
7-5	Reserved	R	0h	Reserved
4	BOSD_EN	RW	0h	Brown out prevention enable. 0b = Disabled 1b = Enabled
3	BOP_HLD_CLR	RW	0h	BOP infinite hold clear (self clearing). 0b = Don't clear 1b = Clear
2	BOP_INF_HLD	RW	0h	Infinite hold on brown out event. 0b = Use BOP_HLD_TM after brown out event 1b = Don't release until BOP_HLD_CLR is asserted high
1	BOP_MUTE	RW	0h	Mute on brown out event. 0b = Don't mute 1b = Mute followed by device shutdown
0	BOP_EN	RW	1h	Brown out prevention enable. 0b = Disabled 1b = Enabled

8.5.23 BOP_CFG0 (page=0x00 address=0x15) [reset=2Eh]

BOP attack rate, attack step size and hold time.

Figure 8-43. BOP_CFG0 Register Address: 0x15

7	6	5	4	3	2	1	0
BOP_ATK_RT[2:0]			BOP_ATK_ST[1:0]		BOP_HLD_TM[2:0]		
RW-1h			RW-1h		RW-6h		

LEGEND: R/W = Read/Write; R = Read only; -n = value after reset

Table 8-123. Brown Out Prevention 2 Field Descriptions

Bit	Field	Type	Reset	Description
7-5	BOP_ATK_RT[2:0]	RW	1h	Brown out prevention attack rate. 000b = 1 step in 1 sample 001b = 1 step in 2 samples 010b = 1 step in 4 samples 011b = 1 step in 8 samples 100b = 1 step in 16 samples 101b = 1 step in 32 samples 110b = 1 step in 64 samples 111b = 1 step in 128 samples
4-3	BOP_ATK_ST[1:0]	RW	1h	Brown out prevention attack step size. 00b = 0.5 dB 01b = 1 dB 10b = 1.5 dB 11b = 2 dB
2-0	BOP_HLD_TM[2:0]	RW	6h	Brown out prevention hold time. 000b = 0 ms 001b = 10 ms 010b = 25 ms 011b = 50 ms 100b = 100 ms 101b = 250 ms 110b = 500 ms 111b = 1000 ms

8.5.24 BIL_and_ICLA_CFG0 (page=0x00 address=0x16) [reset=60h]

Boost Current limiter and ICLA

Figure 8-44. BIL_and_ICLA_CFG0 Register Address: 0x16

7	6	5	4	3	2	1	0
Reserved	BIL_HLD_TM[2:0]			Reserved			
R-0h	RW-6h			R-0h			

LEGEND: R/W = Read/Write; R = Read only; -n = value after reset

Table 8-124. Boost Current limiter and ICLA Field Descriptions

Bit	Field	Type	Reset	Description
7	Reserved	R	0h	Reserved
6-4	BIL_HLD_TM[2:0]	RW	6h	VBAT current limiter hold time 000b = 0 ms 001b = 10 ms 010b = 25 ms 011b = 50 ms 100b = 100 ms 101b = 250 ms 110b = 500 ms 111b = 1000 ms
3-0	Reserved	R	0h	Reserved

8.5.25 BIL_ICLA_CFG1 (page=0x00 address=0x17) [reset=0h]

ICLA starting time slot and enable.

Figure 8-45. BIL_ICLA_CFG1 Register Address: 0x17

7	6	5	4	3	2	1	0
Reserved							
RW-0h							

LEGEND: R/W = Read/Write; R = Read only; -n = value after reset

Table 8-125. Inter Chip Limiter Alignment 0 Field Descriptions

Bit	Field	Type	Reset	Description
7-0	Reserved	RW	0h	Reserved

8.5.26 GAIN_ICLA_CFG0 (page=0x00 address=0x18) [reset=0h]

ICLA starting time slot and enable.

Figure 8-46. GAIN_ICLA_CFG0 Register Address: 0x18

7	6	5	4	3	2	1	0
Reserved							
R-0h							

LEGEND: R/W = Read/Write; R = Read only; -n = value after reset

Table 8-126. Inter Chip Limiter Alignment 0 Field Descriptions

Bit	Field	Type	Reset	Description
7-0	Reserved	R	0h	Reserved

8.5.27 ICLA_CFG1 (page=0x00 address=0x19) [reset=0h]

ICLA time slot enables.

Figure 8-47. ICLA_CFG1 Register Address: 0x19

7	6	5	4	3	2	1	0
Reserved							
RW-0h							

LEGEND: R/W = Read/Write; R = Read only; -n = value after reset

Table 8-127. Inter Chip Limiter Alignment 1 Field Descriptions

Bit	Field	Type	Reset	Description
7-0	Reserved	RW	0h	Reserved

8.5.28 INT_MASK0 (page=0x00 address=0x1A) [reset=FCh]

Interrupt masks.

Figure 8-48. INT_MASK0 Register Address: 0x1A

7	6	5	4	3	2	1	0
INT_MASK0[7]	INT_MASK0[6]	INT_MASK0[5]	INT_MASK0[4]	INT_MASK0[3]	INT_MASK0[2]	INT_MASK0[1]	INT_MASK0[0]
RW-1h	RW-1h	RW-1h	RW-1h	RW-1h	RW-1h	RW-0h	RW-0h

LEGEND: R/W = Read/Write; R = Read only; -n = value after reset

Table 8-128. Interrupt Mask 0 Field Descriptions

Bit	Field	Type	Reset	Description
7	INT_MASK0[7]	RW	1h	Limiter mute mask. 0b = Don't Mask 1b = Mask
6	INT_MASK0[6]	RW	1h	Limiter infinite hold mask. 0b = Don't Mask 1b = Mask

Table 8-128. Interrupt Mask 0 Field Descriptions (continued)

Bit	Field	Type	Reset	Description
5	INT_MASK0[5]	RW	1h	Limiter max attenuation mask. 0b = Don't Mask 1b = Mask
4	INT_MASK0[4]	RW	1h	VBAT below limiter inflection point mask. 0b = Don't Mask 1b = Mask
3	INT_MASK0[3]	RW	1h	Limiter active mask. 0b = Don't Mask 1b = Mask
2	INT_MASK0[2]	RW	1h	TDM clock error mask. 0b = Don't Mask 1b = Mask
1	INT_MASK0[1]	RW	0h	Over current error mask. 0b = Don't Mask 1b = Mask
0	INT_MASK0[0]	RW	0h	Over temp error mask. 0b = Don't Mask 1b = Mask

8.5.29 INT_MASK1 (page=0x00 address=0x1B) [reset=A6h]

Interrupt masks.

Figure 8-49. INT_MASK1 Register Address: 0x1B

7	6	5	4	3	2	1	0
Reserved	Reserved	INT_MASK1[5]	INT_MASK1[4:3][1:0]		INT_MASK1[2]	INT_MASK1[1]	INT_MASK1[0]
RW-1h	RW-0h	RW-1h	RW-0h		RW-1h	RW-1h	RW-0h

LEGEND: R/W = Read/Write; R = Read only; -n = value after reset

Table 8-129. Interrupt Mask 1 Field Descriptions

Bit	Field	Type	Reset	Description
7	Reserved	RW	1h	Reserved
6	Reserved	RW	0h	Reserved
5	INT_MASK1[5]	RW	1h	Load Diagnostic Completion Mask 0b = Don't Mask 1b = Masked
4-3	INT_MASK1[4:3]	RW	0h	Speaker open load mask 00b = Don't Mask 01b = Mask open Load detection 10b = Mask Short Load detection 11b = Mask both Open, Short Load detection
2	INT_MASK1[2]	RW	1h	Brownout device power down start mask 0b = Don't Mask 1b = Mask
1	INT_MASK1[1]	RW	1h	Brownout Protection Active mask 0b = Don't Mask 1b = Mask
0	INT_MASK1[0]	RW	0h	VBAT Brown out detected mask 0b = Don't Mask 1b = Mask

8.5.30 INT_MASK2 (page=0x00 address=0x1C) [reset=DFh]

Interrupt masks.

Figure 8-50. INT_MASK2 Register Address: 0x1C

7	6	5	4	3	2	1	0
INT_MASK2[7]	INT_MASK2[6]	INT_MASK2[5]	INT_MASK2[4]	INT_MASK2[3]	INT_MASK2[2]	INT_MASK2[1]	INT_MASK2[0]
RW-1h	RW-1h	RW-0h	RW-1h	RW-1h	RW-1h	RW-1h	RW-1h

LEGEND: R/W = Read/Write; R = Read only; -n = value after reset

Table 8-130. Interrupt Mask 2 Field Descriptions

Bit	Field	Type	Reset	Description
7	INT_MASK2[7]	RW	1h	DAC MOD clock error mask 0b = Don't Mask 1b = Mask
6	INT_MASK2[6]	RW	1h	Boost Clock Error mask 0b = Don't Mask 1b = Mask
5	INT_MASK2[5]	RW	0h	VBAT POR mask 0b = Don't Mask 1b = Mask
4	INT_MASK2[4]	RW	1h	PLL Lock interrupt mask 0b = Don't Mask 1b = Mask
3	INT_MASK2[3]	RW	1h	DC DETECT mask 0b = Don't Mask 1b = Mask
2	INT_MASK2[2]	RW	1h	BOOST OV Clamp interrupt mask 0b = Don't Mask 1b = Mask
1	INT_MASK2[1]	RW	1h	CP PG mask 0b = Don't Mask 1b = Mask
0	INT_MASK2[0]	RW	1h	Device power up intp mask 0b = Don't Mask 1b = Mask

8.5.31 INT_MASK3 (page=0x00 address=0x1D) [reset=FFh]

Interrupt masks.

Figure 8-51. INT_MASK3 Register Address: 0x1D

7	6	5	4	3	2	1	0
INT_MASK3[7]	Reserved	Reserved	INT_MASK3[4]	INT_MASK3[3]	Reserved	Reserved	Reserved
RW-1h	RW-1h	RW-1h	RW-1h	RW-1h	RW-1h	RW-1h	RW-1h

LEGEND: R/W = Read/Write; R = Read only; -n = value after reset

Table 8-131. Interrupt Mask 3 Field Descriptions

Bit	Field	Type	Reset	Description
7	INT_MASK3[7]	RW	1h	Device power down intp mask 0b = Don't Mask 1b = Mask
6	Reserved	RW	1h	Reserved
5	Reserved	RW	1h	Reserved
4	INT_MASK3[4]	RW	1h	PDM mic clock error intp mask 0b = Don't Mask 1b = Mask
3	INT_MASK3[3]	RW	1h	ASI2 clock error intp mask 0b = Don't Mask 1b = Mask

Table 8-131. Interrupt Mask 3 Field Descriptions (continued)

Bit	Field	Type	Reset	Description
2	Reserved	RW	1h	Reserved
1	Reserved	RW	1h	Reserved
0	Reserved	RW	1h	Reserved

8.5.32 INT_LIVE0 (page=0x00 address=0x1F) [reset=0h]

Live interrupt readback.

Figure 8-52. INT_LIVE0 Register Address: 0x1F

7	6	5	4	3	2	1	0
INT_LIVE0[7]	INT_LIVE0[6]	INT_LIVE0[5]	INT_LIVE0[4]	INT_LIVE0[3]	INT_LIVE0[2]	INT_LIVE0[1]	INT_LIVE0[0]
R-0h	R-0h	R-0h	R-0h	R-0h	R-0h	R-0h	R-0h

LEGEND: R/W = Read/Write; R = Read only; -n = value after reset

Table 8-132. Live Interrupt Readback 0 Field Descriptions

Bit	Field	Type	Reset	Description
7	INT_LIVE0[7]	R	0h	Interrupt due to limiter mute. 0b = No interrupt 1b = Interrupt
6	INT_LIVE0[6]	R	0h	Interrupt due to limiter infinite hold. 0b = No interrupt 1b = Interrupt
5	INT_LIVE0[5]	R	0h	Interrupt due to limiter max attenuation. 0b = No interrupt 1b = Interrupt
4	INT_LIVE0[4]	R	0h	Interrupt due to VBAT below limiter inflection point. 0b = No interrupt 1b = Interrupt
3	INT_LIVE0[3]	R	0h	Interrupt due to limiter active. 0b = No interrupt 1b = Interrupt
2	INT_LIVE0[2]	R	0h	Interrupt due to TDM clock error. 0b = No interrupt 1b = Interrupt
1	INT_LIVE0[1]	R	0h	Interrupt due to over current error. 0b = No interrupt 1b = Interrupt
0	INT_LIVE0[0]	R	0h	Interrupt due to over temp error. 0b = No interrupt 1b = Interrupt

8.5.33 INT_LIVE1 (page=0x00 address=0x20) [reset=0h]

Live interrupt readback.

Figure 8-53. INT_LIVE1 Register Address: 0x20

7	6	5	4	3	2	1	0
Reserved	Reserved	INT_LIVE1[5]	INT_LIVE1[4]	INT_LIVE1[3]	INT_LIVE1[2]	INT_LIVE1[1]	INT_LIVE1[0]
R-0h	R-0h	R-0h	R-0h	R-0h	R-0h	R-0h	R-0h

LEGEND: R/W = Read/Write; R = Read only; -n = value after reset

Table 8-133. Live Interrupt Readback 1 Field Descriptions

Bit	Field	Type	Reset	Description
7	Reserved	R	0h	Reserved
6	Reserved	R	0h	Reserved
5	INT_LIVE1[5]	R	0h	Reserved
4	INT_LIVE1[4]	R	0h	Reserved
3	INT_LIVE1[3]	R	0h	Reserved
2	INT_LIVE1[2]	R	0h	Reserved
1	INT_LIVE1[1]	R	0h	Brownout Protection Active flag 0b = No interrupt 1b = Interrupt
0	INT_LIVE1[0]	R	0h	Interrupt due to VBAT brown out detected flag. 0b = No interrupt 1b = Interrupt

8.5.34 INT_LIVE3 (page=0x00 address=0x21) [reset=0h]

Live interrupt readback.

Figure 8-54. INT_LIVE3 Register Address: 0x21

7	6	5	4	3	2	1	0
INT_LIVE2[7]	INT_LIVE2[6]	INT_LIVE2[5]	INT_LIVE2[4]	INT_LIVE2[3]	INT_LIVE2[2]	INT_LIVE2[1]	INT_LIVE2[0]
R-0h	R-0h	R-0h	R-0h	R-0h	R-0h	R-0h	R-0h

LEGEND: R/W = Read/Write; R = Read only; -n = value after reset

Table 8-134. Live Interrupt Readback 2 Field Descriptions

Bit	Field	Type	Reset	Description
7	INT_LIVE2[7]	R	0h	DAC MOD clock error flag 0b = No interrupt 1b = Interrupt
6	INT_LIVE2[6]	R	0h	Boost Clock error flag 0b = No interrupt 1b = Interrupt
5	INT_LIVE2[5]	R	0h	VBAT_POR flag 0b = No interrupt 1b = Interrupt
4	INT_LIVE2[4]	R	0h	PLL LOCK flag 0b = No interrupt 1b = Interrupt
3	INT_LIVE2[3]	R	0h	DC DETECT flag 0b = No interrupt 1b = Interrupt
2	INT_LIVE2[2]	R	0h	BOOST OV Clamp flag 0b = No interrupt 1b = Interrupt
1	INT_LIVE2[1]	R	0h	CP PG flag 0b = No interrupt 1b = Interrupt
0	INT_LIVE2[0]	R	0h	Device power up flag 0b = No interrupt 1b = Interrupt

8.5.35 INT_LIVE4 (page=0x00 address=0x22) [reset=0h]

Live interrupt readback.

Figure 8-55. INT_LIVE4 Register Address: 0x22

7	6	5	4	3	2	1	0
INT_LIVE3[7]	Reserved	Reserved	INT_LIVE3[4]	INT_LIVE3[3]	Reserved	Reserved	Reserved
R-0h	R-0h	R-0h	R-0h	R-0h	R-0h	R-0h	R-0h

LEGEND: R/W = Read/Write; R = Read only; -n = value after reset

Table 8-135. Live Interrupt Readback 3 Field Descriptions

Bit	Field	Type	Reset	Description
7	INT_LIVE3[7]	R	0h	Device power down flag 0b = No interrupt 1b = Interrupt
6	Reserved	R	0h	Reserved
5	Reserved	R	0h	Reserved
4	INT_LIVE3[4]	R	0h	PDM mic clock error flag 0b = No interrupt 1b = Interrupt
3	INT_LIVE3[3]	R	0h	ASI2 clock error flag 0b = No interrupt 1b = Interrupt
2	Reserved	R	0h	Reserved
1	Reserved	R	0h	Reserved
0	Reserved	R	0h	Reserved

8.5.36 INT_LTCH0 (page=0x00 address=0x24) [reset=0h]

Latched interrupt readback.

Figure 8-56. INT_LTCH0 Register Address: 0x24

7	6	5	4	3	2	1	0
INT_LTCH0[7]	INT_LTCH0[6]	INT_LTCH0[5]	INT_LTCH0[4]	INT_LTCH0[3]	INT_LTCH0[2]	INT_LTCH0[1]	INT_LTCH0[0]
R-0h	R-0h	R-0h	R-0h	R-0h	R-0h	R-0h	R-0h

LEGEND: R/W = Read/Write; R = Read only; -n = value after reset

Table 8-136. Latched Interrupt Readback 0 Field Descriptions

Bit	Field	Type	Reset	Description
7	INT_LTCH0[7]	R	0h	Interrupt due to limiter mute (cleared using CLR_INTP_LTCH). 0b = No interrupt 1b = Interrupt
6	INT_LTCH0[6]	R	0h	Interrupt due to limiter infinite hold (cleared using CLR_INTP_LTCH). 0b = No interrupt 1b = Interrupt
5	INT_LTCH0[5]	R	0h	Interrupt due to limiter max attenuation (cleared using CLR_INTP_LTCH). 0b = No interrupt 1b = Interrupt
4	INT_LTCH0[4]	R	0h	Interrupt due to VBAT below limiter inflection point (cleared using CLR_INTP_LTCH). 0b = No interrupt 1b = Interrupt
3	INT_LTCH0[3]	R	0h	Interrupt due to limiter active (cleared using CLR_INTP_LTCH). 0b = No interrupt 1b = Interrupt

Table 8-136. Latched Interrupt Readback 0 Field Descriptions (continued)

Bit	Field	Type	Reset	Description
2	INT_LTCH0[2]	R	0h	Interrupt due to TDM clock error (cleared using CLR_INTP_LTCH). 0b = No interrupt 1b = Interrupt
1	INT_LTCH0[1]	R	0h	Interrupt due to over current error (cleared using CLR_INTP_LTCH). 0b = No interrupt 1b = Interrupt
0	INT_LTCH0[0]	R	0h	Interrupt due to over temp error (cleared using CLR_INTP_LTCH). 0b = No interrupt 1b = Interrupt

8.5.37 INT_LTCH1 (page=0x00 address=0x25) [reset=0h]

Latched interrupt readback.

Figure 8-57. INT_LTCH1 Register Address: 0x25

7	6	5	4	3	2	1	0
Reserved	Reserved	INT_LTCH1[5]	INT_LTCH1[4:3][1:0]		INT_LTCH1[2]	INT_LTCH1[1]	INT_LTCH1[0]
R-0h	R-0h	R-0h	R-0h		R-0h	R-0h	R-0h

LEGEND: R/W = Read/Write; R = Read only; -n = value after reset

Table 8-137. Latched Interrupt Readback 1 Field Descriptions

Bit	Field	Type	Reset	Description
7	Reserved	R	0h	Reserved
6	Reserved	R	0h	Reserved
5	INT_LTCH1[5]	R	0h	Interrupt due to Load Diagnostic Mode Completion(cleared using CLR_INTP_LTCH). 0b = Load Diagnostic Mode Not completed 1b = Load Diagnostic Mode Completed
4-3	INT_LTCH1[4:3]	R	0h	Interrupt due to Load Diagnostic Mode Fault Status(cleared using CLR_INTP_LTCH). 00b = Normal Load 01b = Open Load Detected 10b = Short Load Detected 11b = Reserved
2	INT_LTCH1[2]	R	0h	Interrupt due to Brownout Protection Triggered shutdown (cleared using CLR_INTP_LTCH) 0b = No interrupt 1b = Interrupt
1	INT_LTCH1[1]	R	0h	Interrupt due to Brownout Protection Active flag (cleared using CLR_INTP_LTCH) 0b = No interrupt 1b = Interrupt
0	INT_LTCH1[0]	R	0h	Interrupt due to VBAT brown out detected flag (cleared using CLR_INTP_LTCH). 0b = No interrupt 1b = Interrupt

8.5.38 INT_LTCH3 (page=0x00 address=0x26) [reset=0h]

Latched interrupt readback.

Figure 8-58. INT_LTCH3 Register Address: 0x26

7	6	5	4	3	2	1	0
INT_LTCH2[7]	INT_LTCH2[6]	INT_LTCH2[5]	INT_LTCH2[4]	INT_LTCH2[3]	INT_LTCH2[2]	INT_LTCH2[1]	INT_LTCH2[0]

Figure 8-58. INT_LTCH3 Register Address: 0x26 (continued)

R-0h	R-0h	R-0h	R-0h	R-0h	R-0h	R-0h	R-0h
------	------	------	------	------	------	------	------

LEGEND: R/W = Read/Write; R = Read only; -n = value after reset

Table 8-138. Latched Interrupt Readback 2 Field Descriptions

Bit	Field	Type	Reset	Description
7	INT_LTCH2[7]	R	0h	Interrupt due to DAC MOD clock error (cleared using CLR_INTP_LTCH) 0b = No interrupt 1b = Interrupt
6	INT_LTCH2[6]	R	0h	Interrupt due to Boost Clock error (cleared using CLR_INTP_LTCH) 0b = No interrupt 1b = Interrupt
5	INT_LTCH2[5]	R	0h	Interrupt due to VBAT_POR (cleared using CLR_INTP_LTCH) 0b = No interrupt 1b = Interrupt
4	INT_LTCH2[4]	R	0h	Interrupt due to PLL LOCK (cleared using CLR_INTP_LTCH) 0b = No interrupt 1b = Interrupt
3	INT_LTCH2[3]	R	0h	Interrupt due to DC DETECT (cleared using CLR_INTP_LTCH) 0b = No interrupt 1b = Interrupt
2	INT_LTCH2[2]	R	0h	Interrupt due to BOOST OV Clamp (cleared using CLR_INTP_LTCH) 0b = No interrupt 1b = Interrupt
1	INT_LTCH2[1]	R	0h	Interrupt due to CP PG(cleared using CLR_INTP_LTCH) 0b = No interrupt 1b = Interrupt
0	INT_LTCH2[0]	R	0h	Interrupt due to DEVICE POWER UP(cleared using CLR_INTP_LTCH) 0b = No interrupt 1b = Interrupt

8.5.39 INT_LTCH4 (page=0x00 address=0x27) [reset=0h]

Latched interrupt readback.

Figure 8-59. INT_LTCH4 Register Address: 0x27

7	6	5	4	3	2	1	0
INT_LTCH3[7]	Reserved	Reserved	INT_LTCH3[4]	INT_LTCH3[3]	Reserved	Reserved	Reserved
R-0h	R-0h	R-0h	R-0h	R-0h	R-0h	R-0h	R-0h

LEGEND: R/W = Read/Write; R = Read only; -n = value after reset

Table 8-139. Latched Interrupt Readback 3 Field Descriptions

Bit	Field	Type	Reset	Description
7	INT_LTCH3[7]	R	0h	Interrupt due to DEVICE POWER DOWN(cleared using CLR_INTP_LTCH) 0b = No interrupt 1b = Interrupt
6	Reserved	R	0h	Reserved
5	Reserved	R	0h	Reserved
4	INT_LTCH3[4]	R	0h	Interrupt due to PDM mic clock error(cleared using CLR_INTP_LTCH) 0b = No interrupt 1b = Interrupt

Table 8-139. Latched Interrupt Readback 3 Field Descriptions (continued)

Bit	Field	Type	Reset	Description
3	INT_LTCH3[3]	R	0h	Interrupt due to ASI2 clock error (cleared using CLR_INTP_LTCH). 0b = No interrupt 1b = Interrupt
2	Reserved	R	0h	Reserved
1	Reserved	R	0h	Reserved
0	Reserved	R	0h	Reserved

8.5.40 VBAT_MSB (page=0x00 address=0x2A) [reset=0h]

MSBs of SAR ADC VBAT conversion.

Figure 8-60. VBAT_MSB Register Address: 0x2A

7	6	5	4	3	2	1	0
VBAT_CNV[9:2]							
R-0h							

LEGEND: R/W = Read/Write; R = Read only; -n = value after reset

Table 8-140. SAR ADC Conversion 0 Field Descriptions

Bit	Field	Type	Reset	Description
7-0	VBAT_CNV[9:2]	R	0h	Returns SAR ADC VBAT conversion MSBs.

8.5.41 VBAT_LSB (page=0x00 address=0x2B) [reset=0h]

LSBs of SAR ADC VBAT conversion.

Figure 8-61. VBAT_LSB Register Address: 0x2B

7	6	5	4	3	2	1	0
VBAT_CNV[1:0]		Reserved					
R-0h		R-0h					

LEGEND: R/W = Read/Write; R = Read only; -n = value after reset

Table 8-141. SAR ADC Conversion 1 Field Descriptions

Bit	Field	Type	Reset	Description
7-6	VBAT_CNV[1:0]	R	0h	Returns SAR ADC VBAT conversion LSBs.
5-0	Reserved	R	0h	Reserved

8.5.42 TEMP (page=0x00 address=0x2C) [reset=0h]

SARD ADC Temp conversion.

Figure 8-62. TEMP Register Address: 0x2C

7	6	5	4	3	2	1	0
TMP_CNV[7:0]							
R-0h							

LEGEND: R/W = Read/Write; R = Read only; -n = value after reset

Table 8-142. SAR ADC Conversion 2 Field Descriptions

Bit	Field	Type	Reset	Description
7-0	TMP_CNV[7:0]	R	0h	Returns SAR ADC temp sensor conversion.

8.5.43 INT & CLK CFG (page=0x00 address=0x30) [reset=19h]

Figure 8-63. INT & CLK CFG Register Address: 0x30

7	6	5	4	3	2	1	0
Reserved	Reserved	Reserved			CLR_INTP_LTC H	IRQZ_PIN_CFG[1:0]	
RW-0h	RW-0h	RW-3h			RW-0h	RW-1h	

LEGEND: R/W = Read/Write; R = Read only; -n = value after reset

Table 8-143. Field Descriptions

Bit	Field	Type	Reset	Description
7	Reserved	RW	0h	Reserved
6	Reserved	RW	0h	Reserved
5-3	Reserved	RW	3h	Reserved
2	CLR_INTP_LTCH	RW	0h	Clear INT_LTCH registers to clear interrupts (self clearing bit) 0b = Don't clear 1b = Clear INT_LTCH registers
1-0	IRQZ_PIN_CFG[1:0]	RW	1h	IRQZ interrupt configuration. 00b = IRQZ will assert on any unmasked live interrupts 01b = IRQZ will assert on any unmasked latched interrupts 10b = IRQZ will assert for 2-4ms one time on any unmasked live interrupt event 11b = IRQZ will assert for 2-4ms every 4ms on any unmasked latched interrupts

8.5.44 DIN_PD (page=0x00 address=0x31) [reset=40h]

Sets enables of input pin weak pull down.

Figure 8-64. DIN_PD Register Address: 0x31

7	6	5	4	3	2	1	0
DIN_PD[7]	Reserved	DIN_PD[5]	DIN_PD[4]	DIN_PD[3]	DIN_PD[2]	DIN_PD[1]	DIN_PD[0]
RW-0h	RW-1h	RW-0h	RW-0h	RW-0h	RW-0h	RW-0h	RW-0h

LEGEND: R/W = Read/Write; R = Read only; -n = value after reset

Table 8-144. Digital Input Pin Pull Down Field Descriptions

Bit	Field	Type	Reset	Description
7	DIN_PD[7]	RW	0h	Weak pull down for SBCLK2 0b = Disabled 1b = Enabled
6	Reserved	RW	1h	Reserved
5	DIN_PD[5]	RW	0h	Weak pull down for SPII2CZ_MISO 0b = Disabled 1b = Enabled
4	DIN_PD[4]	RW	0h	Weak pull down for ADDR_SPICLK 0b = Disabled 1b = Enabled
3	DIN_PD[3]	RW	0h	Weak pull down for SDOOUT 0b = Disabled 1b = Enabled
2	DIN_PD[2]	RW	0h	Weak pull down for SDIN. 0b = Disabled 1b = Enabled
1	DIN_PD[1]	RW	0h	Weak pull down for FSYNC. 0b = Disabled 1b = Enabled

Table 8-144. Digital Input Pin Pull Down Field Descriptions (continued)

Bit	Field	Type	Reset	Description
0	DIN_PD[0]	RW	0h	Weak pull down for SBCLK. 0b = Disabled 1b = Enabled

8.5.45 MISC (page=0x00 address=0x32) [reset=80h]

Set IRQZ pin active state

Figure 8-65. MISC Register Address: 0x32

7	6	5	4	3	2	1	0
IRQZ_POL	Reserved			Reserved		Reserved	Reserved
RW-1h	RW-0h			R-0h		RW-0h	R-0h

LEGEND: R/W = Read/Write; R = Read only; -n = value after reset

Table 8-145. Misc Configuration Field Descriptions

Bit	Field	Type	Reset	Description
7	IRQZ_POL	RW	1h	IRQZ pin polarity for interrupt. 0b = Active high (IRQ) 1b = Active low (IRQZ)
6-4	Reserved	RW	0h	Reserved
3-2	Reserved	R	0h	Reserved
1	Reserved	RW	0h	Reserved
0	Reserved	R	0h	Reserved

8.5.46 BOOST_CFG1 (page=0x00 address=0x33) [reset=34h]

Boost Configure 1

Figure 8-66. BOOST_CFG1 Register Address: 0x33

7	6	5	4	3	2	1	0
BST_MODE	BST_MODE	BST_EN	Reserved		BST_PFML[1:0]		BST_DYNAMIC_ILIM_EN
RW-0h	RW-0h	RW-1h	RW-2h		RW-2h		RW-0h

LEGEND: R/W = Read/Write; R = Read only; -n = value after reset

Table 8-146. Boost Configure 1 Field Descriptions

Bit	Field	Type	Reset	Description
7	BST_MODE	RW	0h	Boost Mode
6	BST_MODE	RW	0h	Boost Mode 00b = Class-H 01b = Class-G 10b = Boost always ON 11b = Boost always OFF(Passthrough)
5	BST_EN	RW	1h	Boost enable 0b = Disabled 1b = Enabled
4-3	Reserved	RW	2h	Reserved
2-1	BST_PFML[1:0]	RW	2h	Boost active mode PFM lower limit 00b = No lower limit 01b = 25 kHz 10b = 50 kHz 11b = 100 kHz

Table 8-146. Boost Configure 1 Field Descriptions (continued)

Bit	Field	Type	Reset	Description
0	BST_DYNAMIC_ILIM_EN	RW	0h	Dynamic Current Limiter based on VBAT 0b = Disabled 1b = Enabled

8.5.47 BOOST_CFG2 (page=0x00 address=0x34) [reset=4Bh]

Boost Configure 2

Figure 8-67. BOOST_CFG2 Register Address: 0x34

7	6	5	4	3	2	1	0
BST_IR[1:0]		BST_SYNC	BST_PA	BST_VREG[3:0]			
RW-1h		RW-0h	RW-0h	RW-Bh			

LEGEND: R/W = Read/Write; R = Read only; -n = value after reset

Table 8-147. Boost Configure 2 Field Descriptions

Bit	Field	Type	Reset	Description
7-6	BST_IR[1:0]	RW	1h	Boost inductor range 00b = less than 0.6 uH 01b = 0.6 uH to 1.3 uH 10b = 1.3 uH to 2.5 uH 11b = Reserved
5	BST_SYNC	RW	0h	Boost sync to clock 0b = Not synced 1b = Synced
4	BST_PA	RW	0h	Boost sync phase 0b = 0 deg 1b = 180 deg
3-0	BST_VREG[3:0]	RW	Bh	Boost Maximum Voltage(Default 11 V) 0000b = Reserved 0001b = 6 V 0010b = 6.5 V 1110b = 12.5 V 1111b = Reserved

8.5.48 BOOST_CFG3 (page=0x00 address=0x35) [reset=74h]

Boost Configure 3

Figure 8-68. BOOST_CFG3 Register Address: 0x35

7	6	5	4	3	2	1	0
BST_CLASSH_STEP_TIME[3:0]				BST_LR[1:0]		Reserved	Reserved
RW-7h				RW-1h		RW-0h	R-0h

LEGEND: R/W = Read/Write; R = Read only; -n = value after reset

Table 8-148. Boost Configure 3 Field Descriptions

Bit	Field	Type	Reset	Description
7-4	BST_CLASSH_STEP_TIME[3:0]	RW	7h	Step Time for Boost if in Class-H mode 0000b = 9us 0001b = 18us 0010b = 36us 0011b = 54us 0100b = 72us 0101b = 90us 0110b = 108us 0111b = 135us 1000b = 162us 1001b = 198us 1010b = 252us 1011b = 342us 1100b = 477us 1101b = 612us 1110b = 792us 1111b = 990us
3-2	BST_LR[1:0]	RW	1h	Slope of boost load regulation. 00b = Reserved 01b = 3A/V; load regulation = 1V (default) 10b = 2A/V; load regulation = 1.5V 11b = Reserved
1	Reserved	RW	0h	Reserved
0	Reserved	R	0h	Reserved

8.5.49 MISC (page=0x00 address=0x3B) [reset=58h]

Figure 8-69. MISC Register Address: 0x3B

7	6	5	4	3	2	1	0
HAPTIC_EN	Reserved		Reserved		Reserved	Reserved	
RW-0h	RW-2h		RW-3h		RW-0h	RW-0h	

LEGEND: R/W = Read/Write; R = Read only; -n = value after reset

Table 8-149. Field Descriptions

Bit	Field	Type	Reset	Description
7	HAPTIC_EN	RW	0h	Haptics mode is 0b = Disabled 1b = Enabled
6-5	Reserved	RW	2h	Reserved
4-3	Reserved	RW	3h	Reserved
2	Reserved	RW	0h	Reserved
1-0	Reserved	RW	0h	Reserved

8.5.50 TG_CFG0 (page=0x00 address=0x3F) [reset=0h]

Tone Generator

Figure 8-70. TG_CFG0 Register Address: 0x3F

7	6	5	4	3	2	1	0
TG1_EN[1:0]		TG1_PINEN[1:0]		Reserved			
RW-0h		RW-0h		R-0h			

LEGEND: R/W = Read/Write; R = Read only; -n = value after reset

Table 8-150. Tone Generator Field Descriptions

Bit	Field	Type	Reset	Description
7-6	TG1_EN[1:0]	RW	0h	Tone Generator 1 is 00b = Disabled or pin triggered 01b = Enabled - play tone 10b = audio level enabled 11b = reserved
5-4	TG1_PINEN[1:0]	RW	0h	Tone pin trigger 00b = Disabled 01b = SDIN 10b = GPIO 11b = AD1
3-0	Reserved	R	0h	Reserved

8.5.51 BST_ILIM_CFG0 (page=0x00 address=0x40) [reset=36h]

Boost ILIM configuration-0

Figure 8-71. BST_ILIM_CFG0 Register Address: 0x40

7	6	5	4	3	2	1	0
BST_SSL[7:6]		BST_ILIM[5:0]					
RW-0h		RW-36h					

LEGEND: R/W = Read/Write; R = Read only; -n = value after reset

Table 8-151. Boost ILIM configuration-0 Field Descriptions

Bit	Field	Type	Reset	Description
7-0	BST_SSL[7:0]	RW	0h	Boost peak current limit 00h = 0.99 A 01h = 1.045 A 02h = 1.1 A ... 36h = 3.96 A 37h = 4 A 38h-3Fh = Reserved

8.5.52 PDM_CONFIG0 (page=0x00 address=0x41) [reset=1h]**Figure 8-72. PDM_CONFIG0 Register Address: 0x41**

7	6	5	4	3	2	1	0
Reserved	PDM_GATE_PA D0[6:6]	PDM_RATE_PA D0[5:5]	DIS_PDM_MIC _CLK_ERR_PA D0[4:4]	PDM_PAD0_C AP_EDGE[3:3]	PDM_MIC2_E N[2:2]	PDM_MIC1_E N[1:1]	PDM_MIC_SLV
R-0h	RW-1h	RW-0h	RW-0h	RW-0h	RW-0h	RW-0h	RW-1h

LEGEND: R/W = Read/Write; R = Read only; -n = value after reset

Table 8-152. Field Descriptions

Bit	Field	Type	Reset	Description
7	Reserved	R	0h	Reserved
6	PDM_GATE_PAD0	RW	1h	Clock gating for master mode PAD0 0b=Disabled 1b=Enabled
5	PDM_RATE_PAD0	RW	0h	PDM data rate of PAD0 0b=3.072 MHz 1b=6.144 MHz
4	DIS_PDM_MIC_CLK_ERR_PAD0	RW	0h	Disable PDM Mic. clock error on PAD0 detection 0b=Clock error detection is enabled 1b=Clock error detection is disabled

Table 8-152. Field Descriptions (continued)

Bit	Field	Type	Reset	Description
3	PDM_PAD0_CAP_EDGE	RW	0h	Capture edge of PDM mic data for PAD0 0b=MIC1 captured on positive edge. MIC2 captured on negative edge 1b=MIC1 captured on negative edge. MIC2 captured on positive edge
2	PDM_MIC2_EN	RW	0h	Control for PDM MIC2 path 0b=MIC2 path is disabled 1b=MIC2 path is enabled
1	PDM_MIC1_EN	RW	0h	Control for PDM MIC1 path 0b=MIC1 path is disabled 1b=MIC1 path is enabled
0	PDM_MIC_SLV	RW	1h	Device in PDM MIC SLAVE or MASTER 0b=Device is in PDM MIC master mode 1b=Device is in PDM Slave mode

8.5.53 DIN_PD & PDM_CONFIG3 (page=0x00 address=0x42) [reset=F8h]

Figure 8-73. DIN_PD & PDM_CONFIG3 Register Address: 0x42

7	6	5	4	3	2	1	0
DIN_PD[14]	DIN_PD[13]	Reserved	wk_pulldown_p dmd_pad0	wk_pulldown_p dmck_pad0	Reserved		
RW-0h	RW-0h	R-0h	RW-0h	RW-0h	R-0h		

LEGEND: R/W = Read/Write; R = Read only; -n = value after reset

Table 8-153. Field Descriptions

Bit	Field	Type	Reset	Description
7	DIN_PD[14]	RW	0h	Weak pull down for SDIN2 0b=Disabled 1b=Enabled
6	DIN_PD[13]	RW	0h	Weak pull down for SDIN1 0b=Disabled 1b=Enabled
5	Reserved	R	0h	Reserved
4	wk_pulldown_pdmd_pad0	RW	0h	Control for pull down of PDMD PAD0 0b=Disable the pull down control 1b=Enable the pull down control
3	wk_pulldown_pdmck_pad0	RW	0h	Control for pull down of PDMD PAD0 0b=Disable the pull down control 1b=Enable the pull down control
2-0	Reserved	R	0h	Reserved

8.5.54 ASI2_CONFIG0 (page=0x00 address=0x43) [reset=8h]

Figure 8-74. ASI2_CONFIG0 Register Address: 0x43

7	6	5	4	3	2	1	0
tx_fill_asi2[7:7]	asi2_sbclk_fs_ratio[6:3]				Reserved		
RW-0h	RW-1h				R-0h		

LEGEND: R/W = Read/Write; R = Read only; -n = value after reset

Table 8-154. Field Descriptions

Bit	Field	Type	Reset	Description
7-0	tx_fill_asi2[7:0]	RW	0h	Reserved

8.5.55 ASI2_CONFIG1 (page=0x00 address=0x44) [reset=0h]

Figure 8-75. ASI2_CONFIG1 Register Address: 0x44

7	6	5	4	3	2	1	0
asi2_auto_rate[7:7]	asi2_tx_lsb_half_cycle_reg[6:6]	rx_edge_asi2[5:5]	tx_edge_asi2[4:4]	Reserved			asi2_sbclk_master
RW-0h	RW-0h	RW-0h	RW-0h	R-0h			RW-0h

LEGEND: R/W = Read/Write; R = Read only; -n = value after reset

Table 8-155. Field Descriptions

Bit	Field	Type	Reset	Description
7-0	asi2_auto_rate[7:0]	RW	0h	ASI2 SBCLK master mode enable 0b = SBCLK2 in slave mode 1b = SBCLK2 in master mode

8.5.56 ASI2_CONFIG2 (page=0x00 address=0x45) [reset=1h]

Figure 8-76. ASI2_CONFIG2 Register Address: 0x45

7	6	5	4	3	2	1	0
tx_offset_asi2[7:5]				rx_offset_asi2[4:0]			
RW-0h				RW-1h			

LEGEND: R/W = Read/Write; R = Read only; -n = value after reset

Table 8-156. Field Descriptions

Bit	Field	Type	Reset	Description
7-0	tx_offset_asi2[7:0]	RW	0h	TDM2 RX start of frame to time slot 0 offset (ASI2_SBCLK cycles)

8.5.57 ASI2_CONFIG3 (page=0x00 address=0x46) [reset=FCh]

Figure 8-77. ASI2_CONFIG3 Register Address: 0x46

7	6	5	4	3	2	1	0
Reserved	asi2_tx_keeper[6:6]	asi2_sdout_bus_keeper_always_en[5:5]	num_slots[4:4]	num_devices[3:2]		my_device_num[1:0]	
R-1h	RW-1h	RW-1h	RW-1h	RW-3h		RW-0h	

LEGEND: R/W = Read/Write; R = Read only; -n = value after reset

Table 8-157. Field Descriptions

Bit	Field	Type	Reset	Description
7-0	Reserved	R	1h	My device number on the common BUS 00b = 1st 01b = 2nd 10b = 3rd 11b = 4th

8.5.58 PVDD_MSB_DSP (page=0x00 address=0x49) [reset=0h]

MSBs of SAR ADC PVDD conversion.

Figure 8-78. PVDD_MSB_DSP Register Address: 0x49

7	6	5	4	3	2	1	0
PVDD_CNV_DSP[9:2]							
R-0h							

LEGEND: R/W = Read/Write; R = Read only; -n = value after reset

Table 8-158. SAR ADC Conversion 0 Field Descriptions

Bit	Field	Type	Reset	Description
7-0	PVDD_CNV_DSP[9:2]	R	0h	Returns SAR ADC PVDD conversion MSBs.

8.5.59 PVDD_LSB_DSP (page=0x00 address=0x4A) [reset=0h]

LSBs of SAR ADC PVDD conversion.

Figure 8-79. PVDD_LSB_DSP Register Address: 0x4A

7	6	5	4	3	2	1	0
PVDD_CNV_DSP[1:0]		Reserved					
R-0h		R-0h					

LEGEND: R/W = Read/Write; R = Read only; -n = value after reset

Table 8-159. SAR ADC Conversion 1 Field Descriptions

Bit	Field	Type	Reset	Description
7-6	PVDD_CNV_DSP[1:0]	R	0h	Returns SAR ADC PVDD conversion LSBs.
5-0	Reserved	R	0h	Reserved

8.5.60 REV_ID (page=0x00 address=0x7D) [reset=0h]

Returns REV and PG ID.

Figure 8-80. REV_ID Register Address: 0x7D

7	6	5	4	3	2	1	0
REV_ID[3:0]				PG_ID[3:0]			
R-0h				R-0h			

LEGEND: R/W = Read/Write; R = Read only; -n = value after reset

Table 8-160. Revision and PG ID Field Descriptions

Bit	Field	Type	Reset	Description
7-4	REV_ID[3:0]	R	0h	Returns the revision ID.
3-0	PG_ID[3:0]	R	0h	Returns the PG ID.

8.5.61 I2C_CKSUM (page=0x00 address=0x7E) [reset=0h]

Returns I2C checksum.

Figure 8-81. I2C_CKSUM Register Address: 0x7E

7	6	5	4	3	2	1	0
I2C_CKSUM[7:0]							
RW-0h							

LEGEND: R/W = Read/Write; R = Read only; -n = value after reset

Table 8-161. I2C Checksum Field Descriptions

Bit	Field	Type	Reset	Description
7-0	I2C_CKSUM[7:0]	RW	0h	Returns I2C checksum. Writing to this register will reset the checksum to the written value. This register is updated on writes to other registers on all books and pages.

8.5.62 BOOK (page=0x00 address=0x7F) [reset=0h]

Device's memory map is divided into pages and books. This register sets the book.

Figure 8-82. BOOK Register Address: 0x7F

7	6	5	4	3	2	1	0
BOOK[7:0]							
RW-0h							

LEGEND: R/W = Read/Write; R = Read only; -n = value after reset

Table 8-162. Device Book Field Descriptions

Bit	Field	Type	Reset	Description
7-0	BOOK[7:0]	RW	0h	Sets the device book. 00h = Book 0 01h = Book 1 ... FFh = Book 255

9 Application and Implementation

Note

Information in the following applications sections is not part of the TI component specification, and TI does not warrant its accuracy or completeness. TI's customers are responsible for determining suitability of components for their purposes. Customers should validate and test their design implementation to confirm system functionality.

9.1 Application Information

The TAS2563 is a digital input high efficiency Class-D audio power amplifier with advanced battery current management and an integrated Class-H boost converter. In auto passthrough mode, the Class-H boost converter generates the Class-D amplifier supply rail. During low Class-D output power, the boost improves efficiency by deactivating and connecting VBAT directly to the Class-D amplifier supply. When high power audio is required, the boost quickly activates to provide louder audio than a stand-alone amplifier connected directly to the battery. To enable load monitoring, the TAS2563 constantly measures the current and voltage across the load and provides a digital stream of this information back to a processor. It is recommended to configure the TAS2563 using [Section 8.3.1](#).

9.2 Typical Application

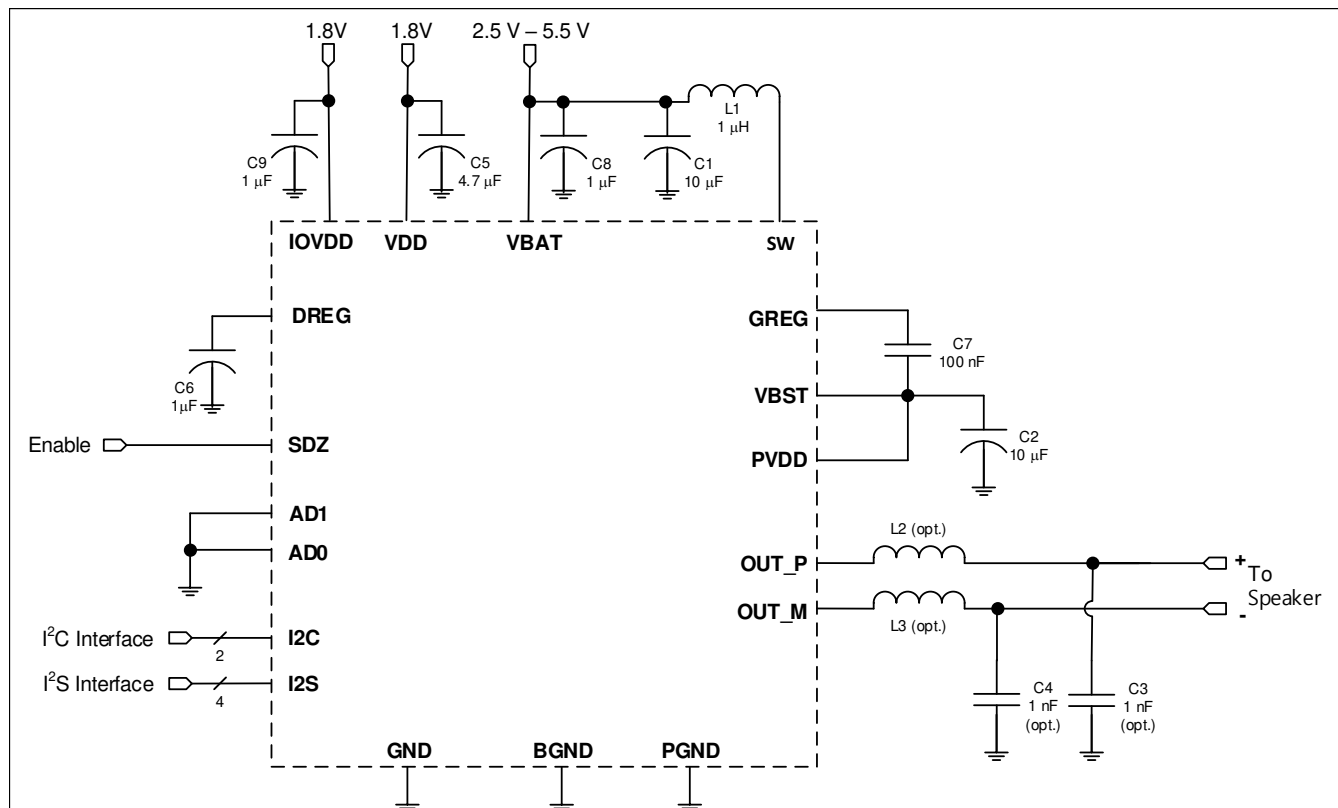

Figure 9-1. Typical Application - Digital Audio Input with 1S Battery Supply

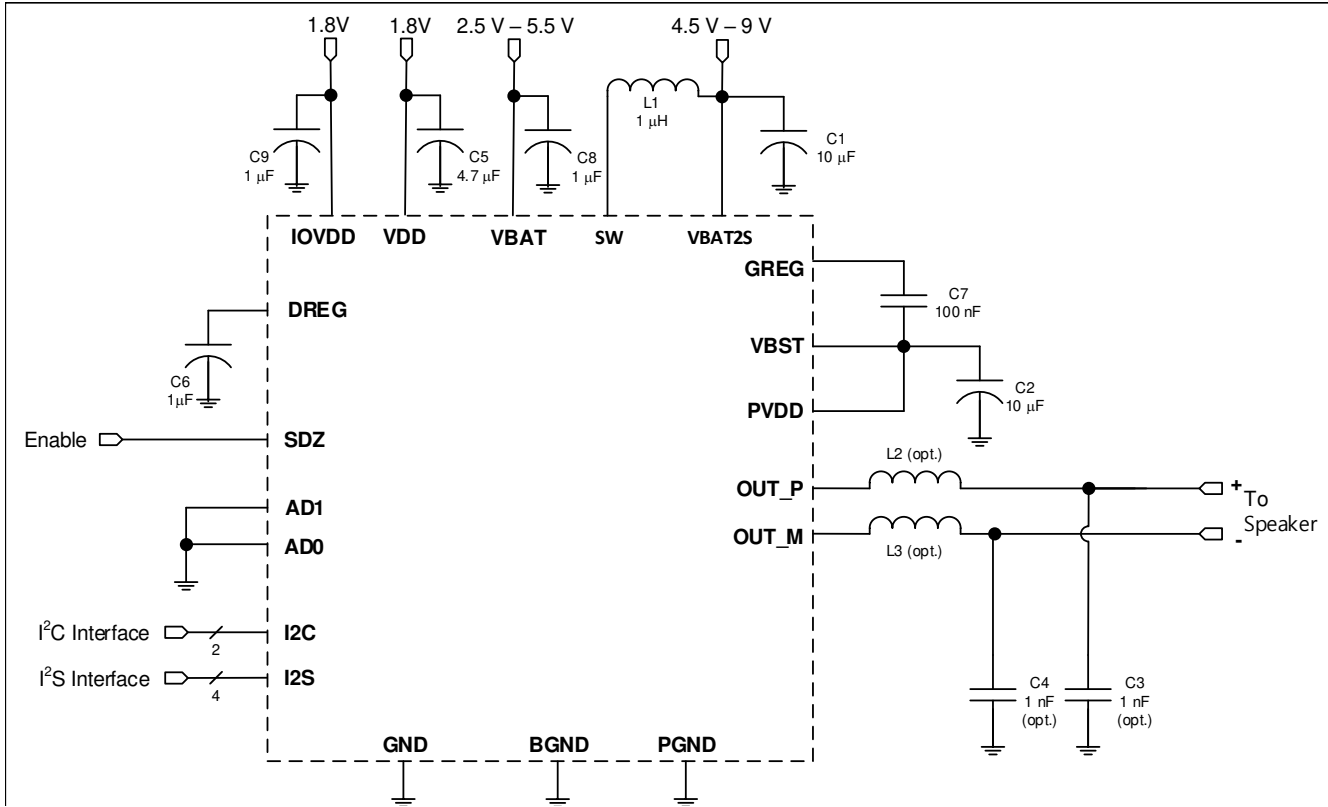

Figure 9-2. Typical Application - Digital Audio Input with 2S Battery Supply (DSBGA Package only)

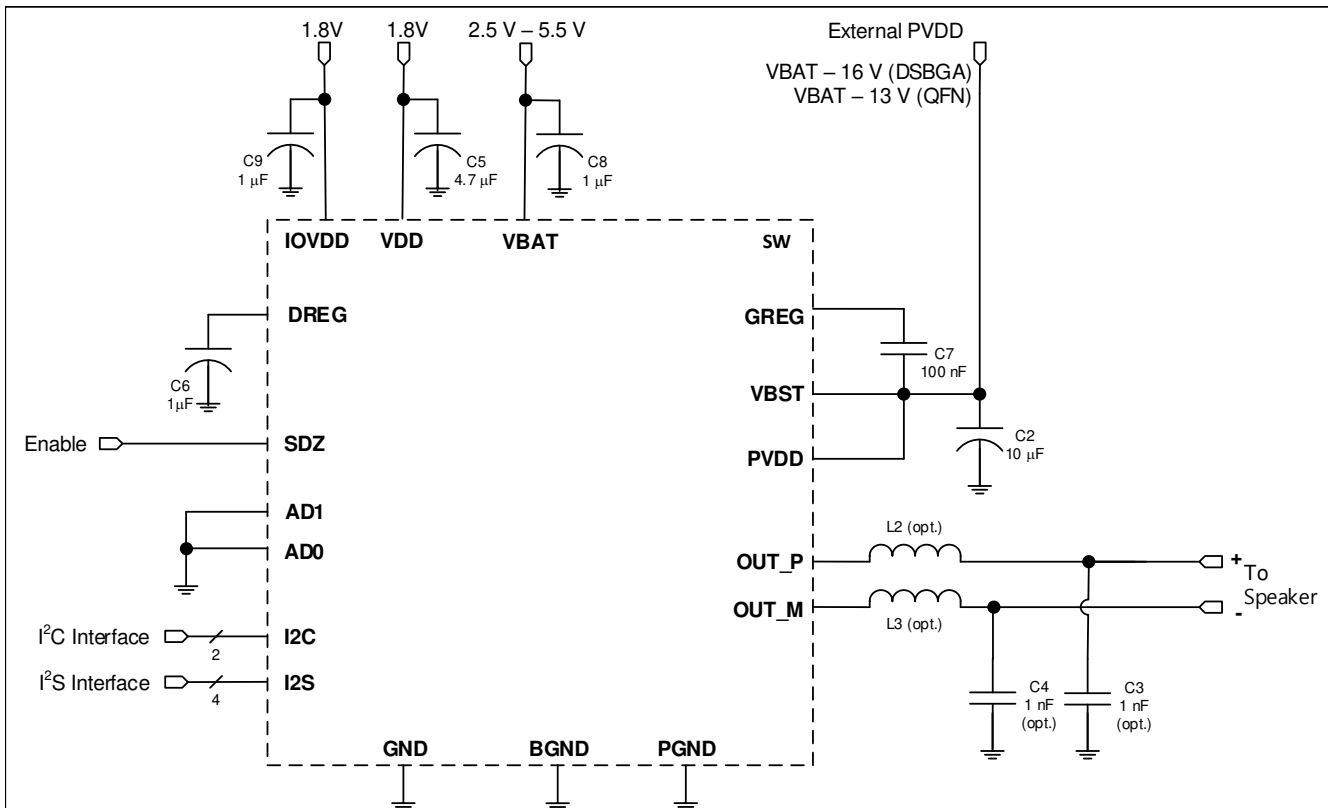

Figure 9-3. Typical Application - Digital Audio Input with external PVDD voltage supply

Table 9-1. Recommended External Components

COMPONENT	DESCRIPTION	SPECIFICATION	MIN	TYP	MAX	UNIT
L1	Boost Converter Inductor ⁽¹⁾	Inductance, 20% Tolerance	0.47	1		μH
		Saturation Current		4.5		A
L2, L3	EMI Filter Inductors (optional). These are not recommended as it degrades THD+N performance. TAS2563 is a filter-less Class-D and does not require these bead inductors.	Impedance at 100 MHz		120		Ω
		DC Resistance			0.095	Ω
		DC Current			2	A
		Size		0402		EIA
C1	Boost Converter Input Capacitor ⁽¹⁾	Capacitance, 20% Tolerance	10			μF
C8			1			μF
C2	Boost Converter Output Capacitor	Type	X5R			
		Capacitance, 20% Tolerance	10		47	μF
		Rated Voltage	16			V
		Capacitance at 11.5 V derating	3.3			μF
C3, C4	EMI Filter Capacitors (optional, must use L2, L3 if C3, C4 used)	Capacitance		1		nF
C5	VDD Decoupling Capacitor	Capacitance	4.7			μF
C6	DREG Decoupling Capacitor	Capacitance	1			μF
C7	GREG Fly Capacitor	Capacitance	100			nF
C9	IOVDD Decoupling Capacitor	Capacitance	1			μF

(1) See section [Section 9.2.2.2](#) for additional requirements on derating, stability, and inductor value trade-offs.

9.2.1 Design Requirements

For this design example, use the parameters shown in [Table 9-2](#).

Table 9-2. Design Parameters

DESIGN PARAMETER	EXAMPLE VALUE
Audio Input	Digital Audio, I ² S
Current and Voltage Data Stream	Digital Audio, I ² S
Mono or Stereo Configuration	Mono
Max Output Power at 1% THD+N	5.0 W

9.2.2 Detailed Design Procedure

9.2.2.1 Mono/Stereo Configuration

In this application, the device is assumed to be operating in mono mode. See [Section 8.3.2](#) for information on changing the I²C address of the TAS2563 to support stereo operation. Mono or stereo configuration does not impact the device performance.

9.2.2.2 Boost Converter Passive Devices

The boost converter requires three passive devices that are labeled L1, C1 and C2 in [Section 9.2](#) and whose specifications are provided in [Table 9-1](#). These specifications are based on the design of the TAS2563 and are necessary to meet the performance targets of the device. In particular, L1 should not be allowed to enter in the current saturation region. The saturation current for L1 should be > I_{LIM} to deliver Class-D peak power.

Additionally, the ratio of L1/C2 (the derated value of C2 at 11.5 V should be used in this ratio) has to be lesser than 1/3 for boost stability. This 1/3 ratio should be maintained including the worst case variation of L1 and C2. To satisfy sufficient energy transfer, L1 needs to be ≥ 0.47 μH at the boost switching frequency (100 kHz to 4 MHz). Using a 0.47 μH will have more boost ripple than a 1.0 μH or 2.2 μH but the high PSRR should minimize the effect from the additional ripple. Finally, the minimum C2 (derated value at programmed boost voltage) should be > 3.3 μF for Class-D power delivery specification.

9.2.2.3 EMI Passive Devices

The TAS2563 supports edge-rate control to minimize EMI, but the system designer may want to include passive devices on the Class-D output devices. These passive devices that are labeled L2, L3, C3 and C4 in [Section 9.2](#) and their recommended specifications are provided in [Table 9-1](#). If C3 and C4 are used, L2 and L3 must also be installed, and C3 and C4 must be placed after L2 and L3 respectively to maintain the stability of the output stage.

9.2.2.4 Miscellaneous Passive Devices

The GREG Capacitor requires 100 nF to meet boost and Class-D power delivery and efficiency specs. For best device performance, the GREG capacitor should be placed very close to the device and be routed with wide traces to minimize the impact of PCB parasitic effects.

9.2.3 Application Curves

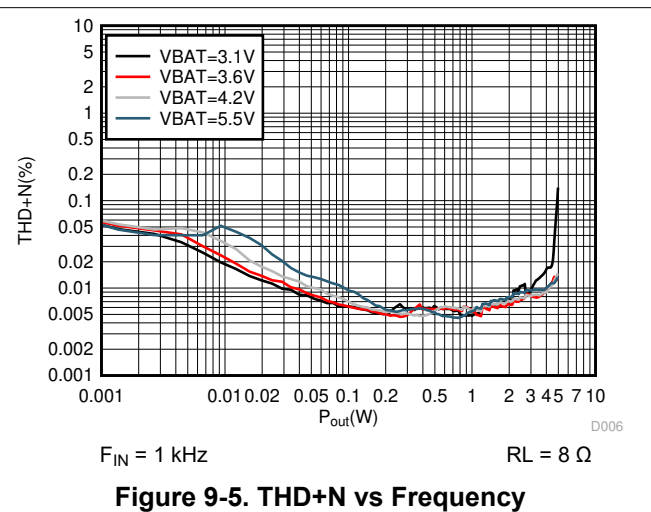
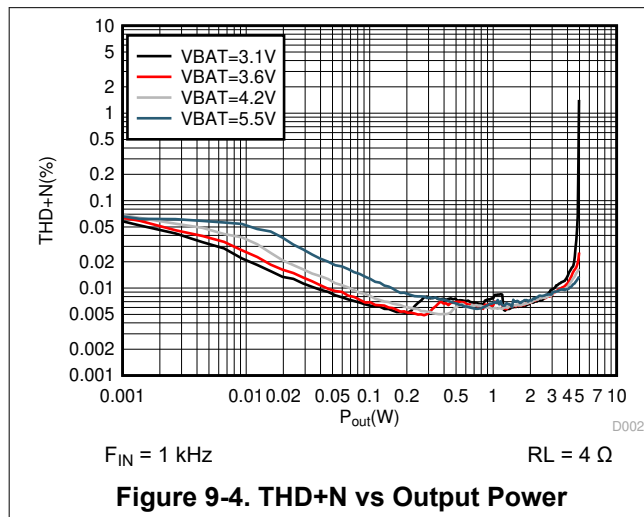

10 Power Supply Recommendations

10.1 Power Supplies

The TAS2563 requires four power supplies:

- Boost Input (terminal: VBAT)
 - Voltage: 2.5 V to 5.5 V
 - Max Current: 5 A for ILIM = 4.0 A (default)
- Analog Supply (terminal: VDD)
 - Voltage: 1.62 V to 1.95 V
 - Max Current: 30 mA
- IO Supply (terminal: IOVDD)
 - Voltage: 1.62 V to 3.6 V
 - Max Current: 30 mA

The decoupling capacitors for the power supplies should be placed close to the device terminals.

10.2 Power Supply Sequencing

The power rail may be brought up and down in any order. There is no requirement on sequencing. However if VDD is present without VBAT an additional rise in VDD current will be observed until VBAT is present.

When the supplies have settled, the SDZ terminal can be set HIGH to operate the device. Additionally the SDZ pin can be tied to VDD and the internal POR will perform a reset of the device. After a hardware or software reset additional commands to the device should be delayed for 100 μ S to allow the OTP to load. The above sequence should be completed before any I²C operation.

10.2.1 Boost Supply Details

The boost supply (VBAT) and associated passives need to be able to support the current requirements of the device. By default, the peak current limit of the boost is set to 4 A. Refer to [Section 8.5.51](#) for information on changing the current limit. A minimum of a 10 μ F capacitor is recommended on the boost supply to quickly support changes in required current. Refer to [Section 9.2](#) for the schematic.

The current requirements can also be reduced by lowering the gain of the amplifier, or in response to decreasing battery through the use of the battery-tracking feature of the TAS2563 described in [Section 8.4.3.6](#).

10.2.2 External Boost Mode (Boost Bypass Mode)

It is very important that during external boost mode, VBAT and SW should be open on board. For more information refer to application note document [SLAA972](#)

11 Layout

11.1 Layout Guidelines

- Place the boost inductor between VBAT and SW close to device terminals with no VIAS between the device terminals and the inductor.
- Place the capacitor between VBST close to device terminals with no VIAS between the device terminals and capacitor.
- Place the capacitor between VBST/VBAT and GND close to device terminals with no VIAS between the device terminals and capacitor.
- Use minimal amount of VIAS for traces that carry high current. These include the traces for VBST, SW, VBAT, PGND and the speaker OUT_P, OUT_M.
- Use epoxy filled vias for the interior pads.
- Connect VSNS_P, VSNS_N as close as possible to the speaker.
 - VSNS_P, VSNS_N should be connected between the EMI ferrite and the speaker if EMI ferrites are used on OUT_P, OUT_M.
 - EMI ferrites must be used if EMI capacitors are used on OUT_P, OUT_M.
- Use a ground plane with multiple vias for each terminal to create a low-impedance connection to GND for minimum ground noise.
- Use supply decoupling capacitors as shown in [Section 9.2](#) and described in [Section 10.1](#).
- Place EMI ferrites, if used, close to the device.

Table 11-1. Pin Layout Guidelines

PIN	MAX PARASITIC INDUCTANCE	LAYOUT RECOMMENDATIONS
BGND, GND, PGND, GNDD	150 pH	Short BGND, GND, GNDD, PGND below the package and connect them to PCB ground plane strongly through multiple vias. Minimize inductance as much as possible
DREG	500 pH	Bypass to GND with capacitor recommended in Table 9-1 . Do not connect to external load. Both ends of decoupling cap should see as low inductance as possible between this pin and gnd pins.
GREG	200 pH	Connect it to PVDD with a star connection and not to boost plane with recommended in Table 9-1 . Do not connect to external load.
PVDD	100 pH	Short it to VBST(boost) plane through strong connection. Connect it to GREG with a star connection and not to boost plane.
SW		Connect to VBAT with boost inductor recommended in Table 9-1 . Reduce parasitic capacitor and resistance for efficiency. Boost inductor should be as close as possible to the SW pin. Inductor should be connected to SW through thick plane. Traces should support currents up to device over-current limit.
VBAT	500 pH	Bypass to GND with capacitor recommended in Table 9-1 . Should be connected to inductor through thick plane. Both ends of decoupling capacitor should see as low inductance as possible between VBAT pin and PGND pin.
VBST	100 pH	Do not connect to external load. Bypass to GND with capacitor recommended in Table 9-1 . Connect to PVDD through thick plane. Both ends of decoupling capacitor should see as low inductance as possible between VBST pin and BGND pin. Traces should support currents up to device over-current limit.
VDD	200 pH	Bypass to GND with capacitor recommended in Table 9-1 . Both the end of decoupling cap should see as low inductance as possible between this pin and GND pin

11.2 Layout Example

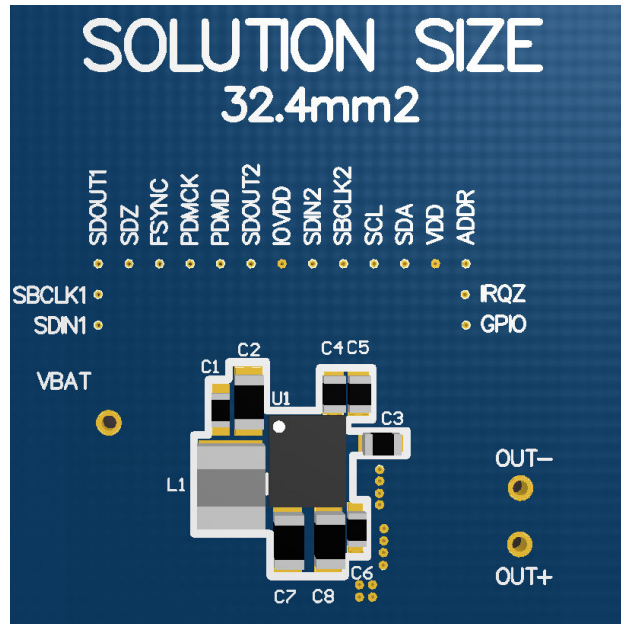

Figure 11-1. WCSP Package PCB Solution

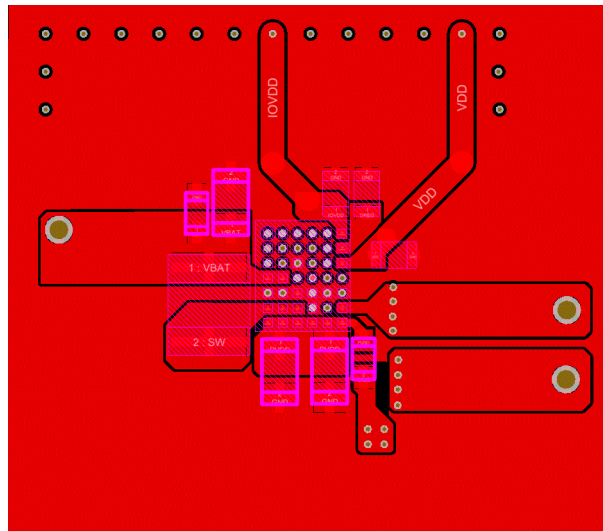

Figure 11-2. WCSP package Top Layer

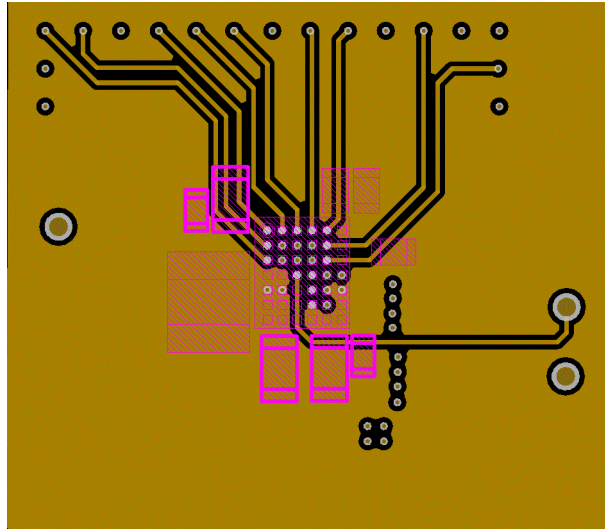

Figure 11-3. WCSP Package Mid-Layer 1

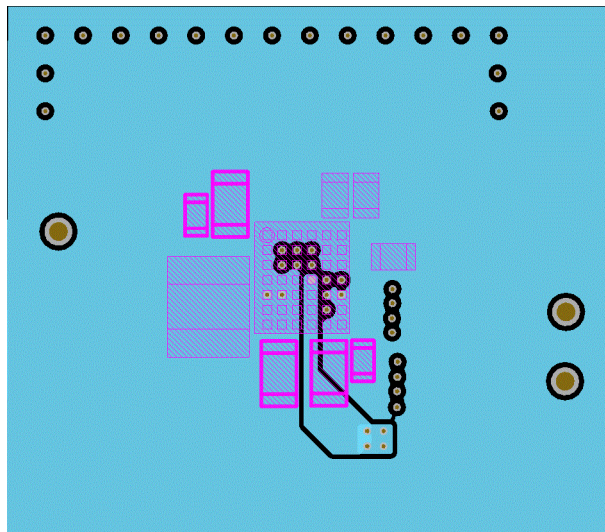

Figure 11-4. WCSP Package Mid-Layer2

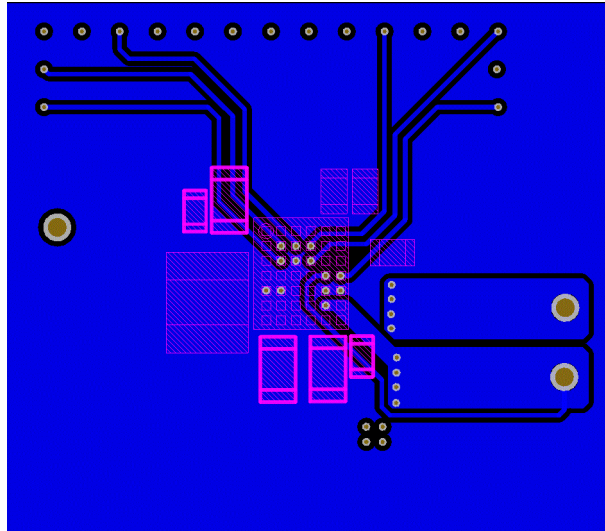

Figure 11-5. WCSP Package Bottom Layer

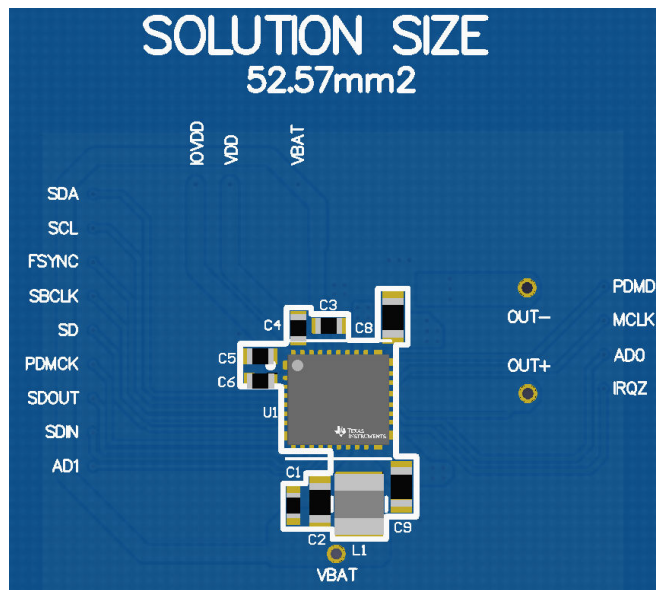

Figure 11-6. QFN Package PCB Solution

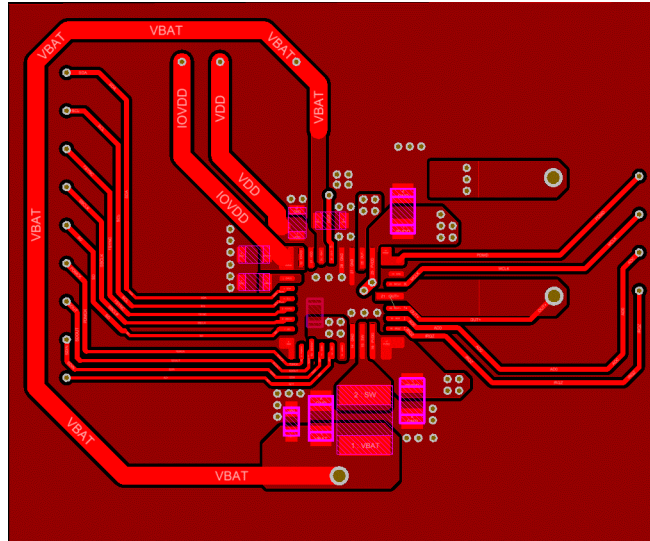

Figure 11-7. QFN Package Top Layer

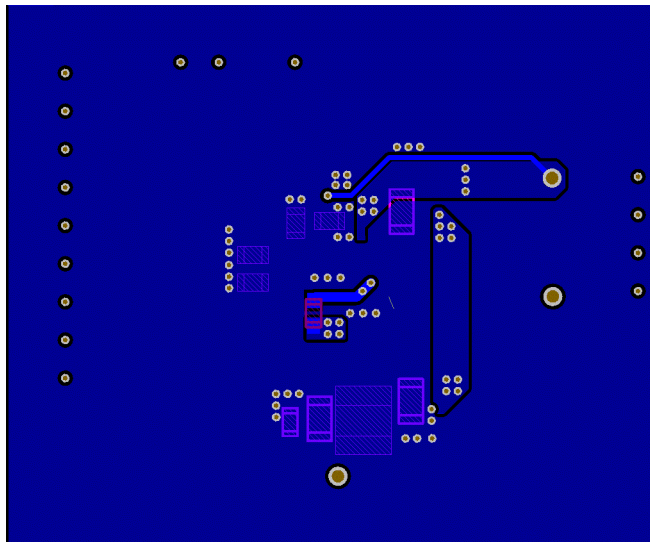

Figure 11-8. QFN Package Bottom Layer

12 Device and Documentation Support

12.1 Documentation Support

12.1.1 Related Documentation

For related documentation see the following: [TAS2563YBGEVM-DC Evaluation module user's guide](#)

12.2 Receiving Notification of Documentation Updates

To receive notification of documentation updates, navigate to the device product folder on ti.com. In the upper right corner, click on *Alert me* to register and receive a weekly digest of any product information that has changed. For change details, review the revision history included in any revised document.

12.3 Support Resources

[TI E2E™ support forums](#) are an engineer's go-to source for fast, verified answers and design help — straight from the experts. Search existing answers or ask your own question to get the quick design help you need.

Linked content is provided "AS IS" by the respective contributors. They do not constitute TI specifications and do not necessarily reflect TI's views; see TI's [Terms of Use](#).

12.4 Trademarks

PurePath™ are trademarks of Texas Instruments.

TI E2E™ is a trademark of Texas Instruments.

All trademarks are the property of their respective owners.

12.5 Electrostatic Discharge Caution



This integrated circuit can be damaged by ESD. Texas Instruments recommends that all integrated circuits be handled with appropriate precautions. Failure to observe proper handling and installation procedures can cause damage.

ESD damage can range from subtle performance degradation to complete device failure. Precision integrated circuits may be more susceptible to damage because very small parametric changes could cause the device not to meet its published specifications.

12.6 Glossary

[TI Glossary](#) This glossary lists and explains terms, acronyms, and definitions.

13 Mechanical, Packaging, and Orderable Information

The following pages include mechanical, packaging, and orderable information. This information is the most current data available for the designated devices. This data is subject to change without notice and revision of this document. For browser-based versions of this data sheet, refer to the left-hand navigation.

TAS2563YBG
YBG0042-C01

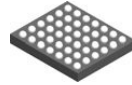

PACKAGE OUTLINE
DSBGA - 0.5 mm max height

DIE SIZE BALL GRID ARRAY

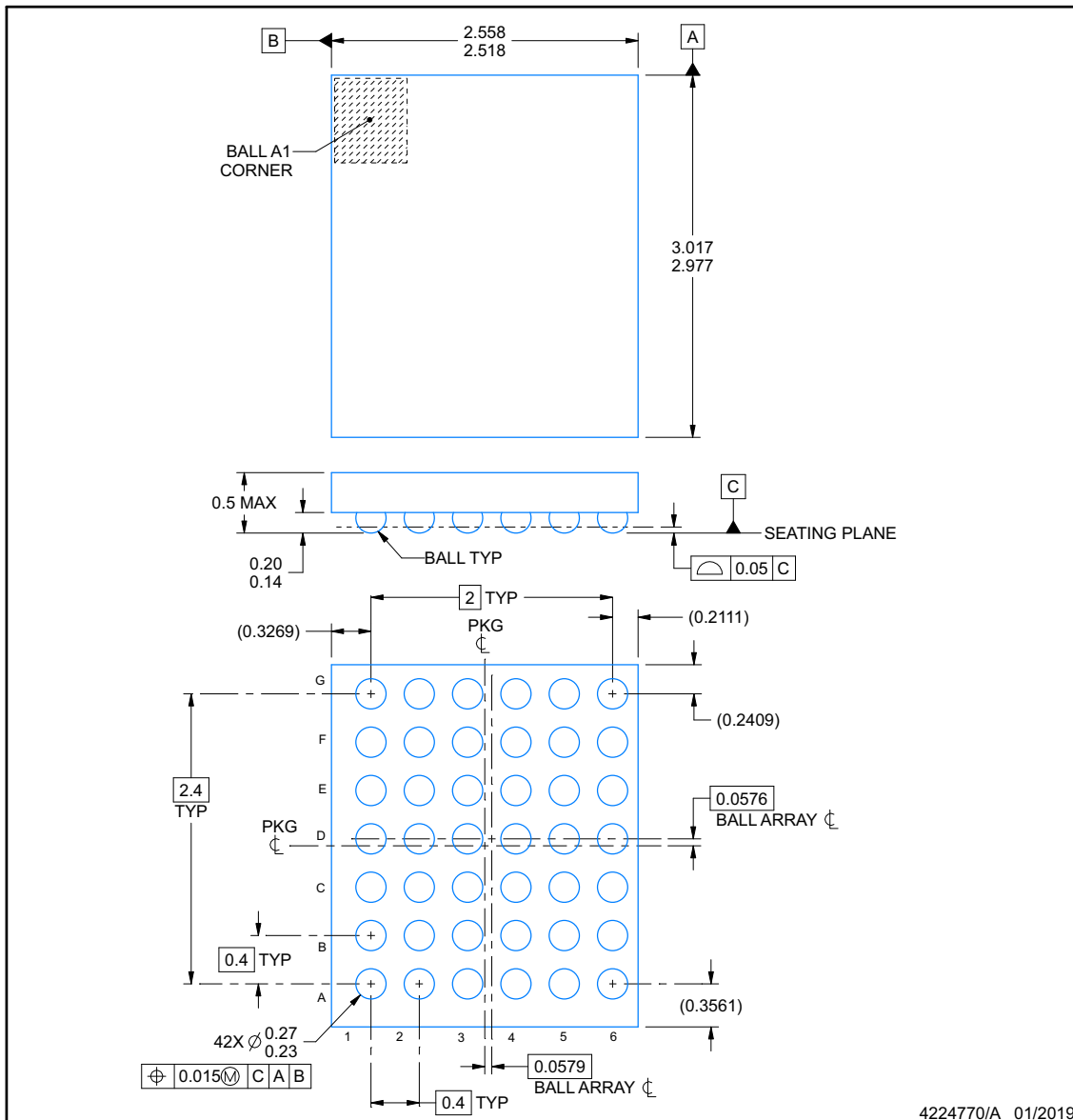

4224770/A 01/2019

NOTES:

1. All linear dimensions are in millimeters. Any dimensions in parenthesis are for reference only. Dimensioning and tolerancing per ASME Y14.5M.
2. This drawing is subject to change without notice.

TAS2563YBG
YBG0042-C01

EXAMPLE BOARD LAYOUT
DSBGA - 0.5 mm max height

DIE SIZE BALL GRID ARRAY

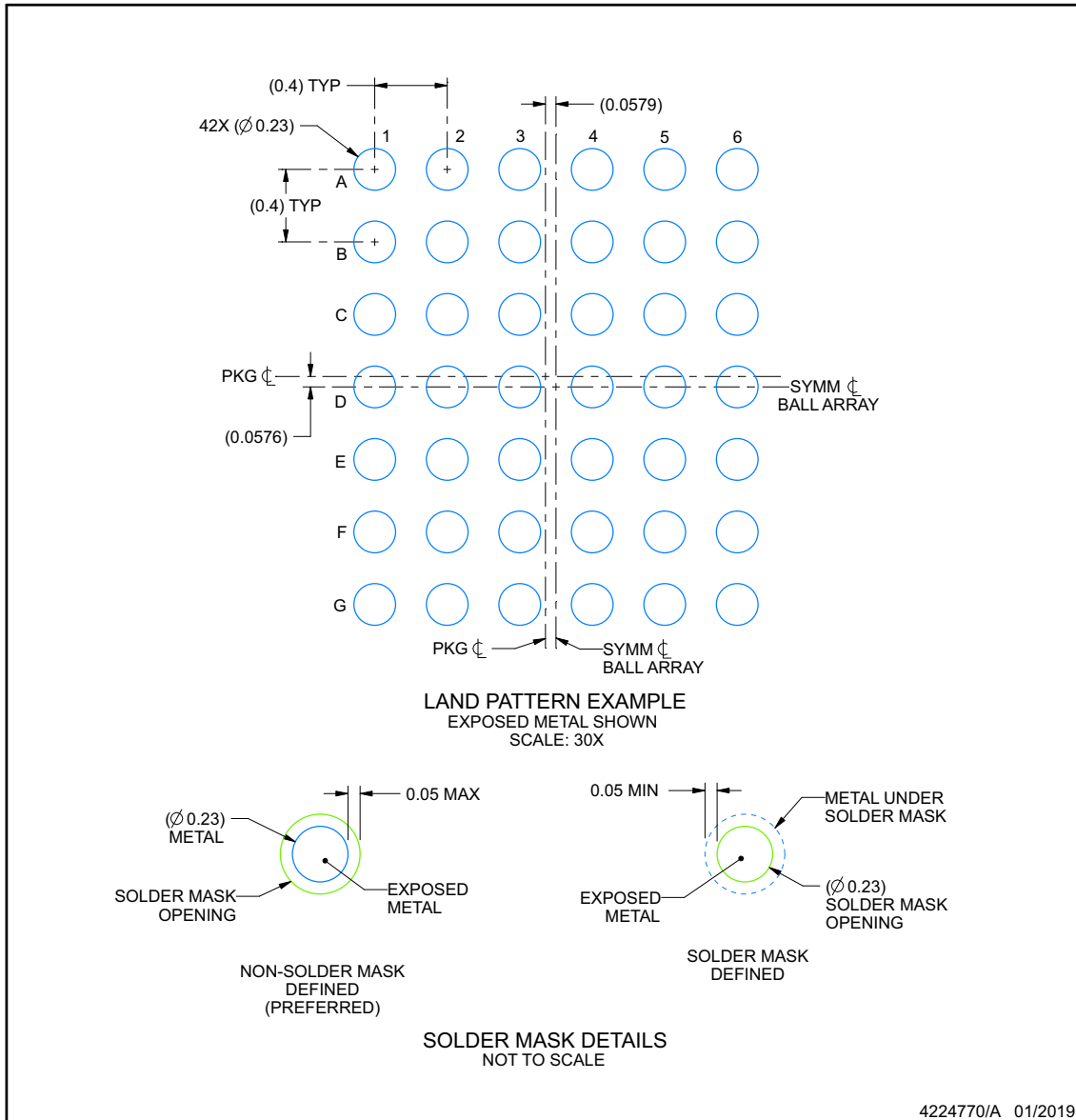

NOTES: (continued)

- Final dimensions may vary due to manufacturing tolerance considerations and also routing constraints. See Texas Instruments Literature No. SNVA009 (www.ti.com/lit/snva009).

**TAS2563YBG
YBG0042-C01**

EXAMPLE STENCIL DESIGN

DSBGA - 0.5 mm max height

DIE SIZE BALL GRID ARRAY

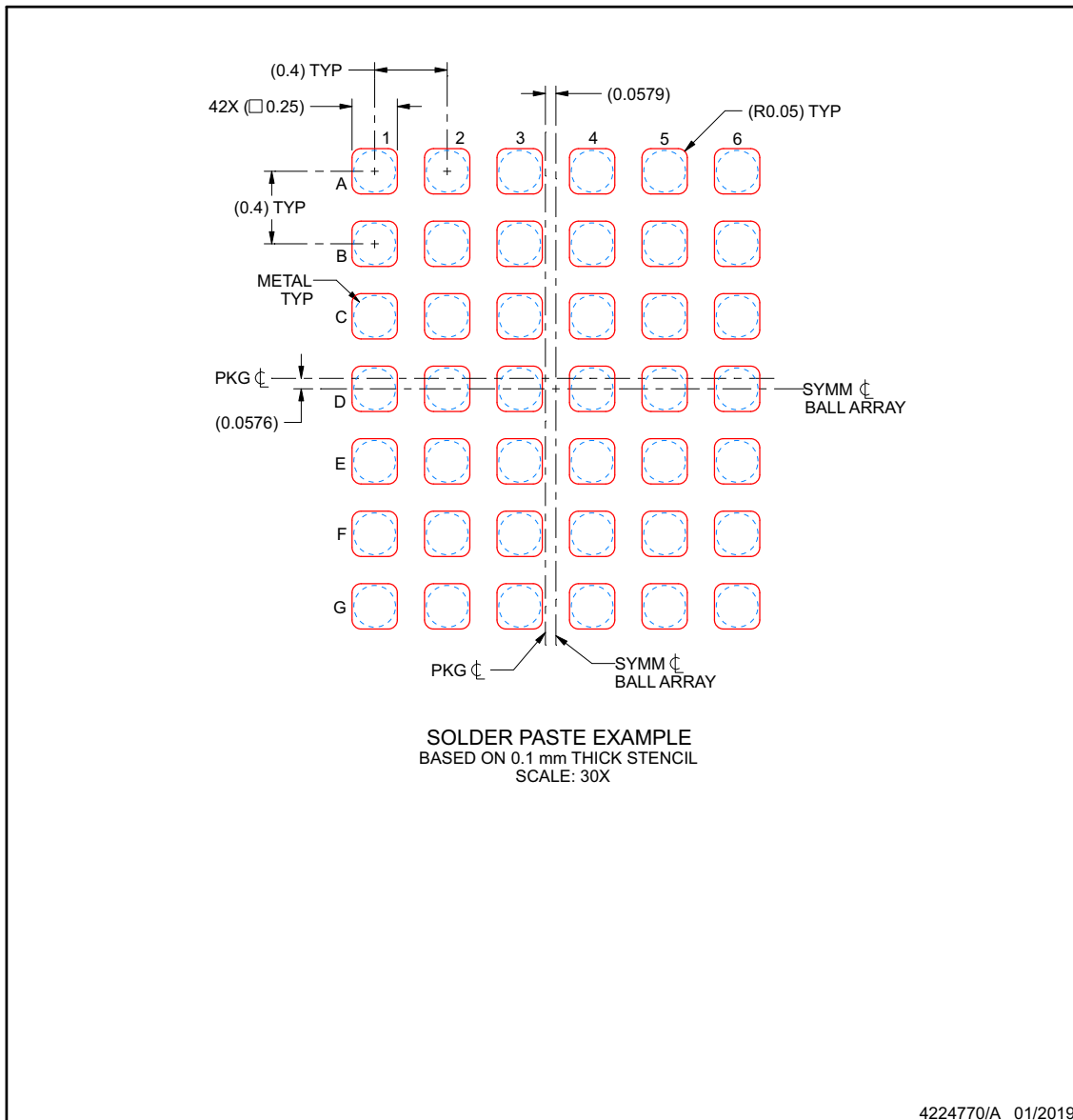

NOTES: (continued)

- 4. Laser cutting apertures with trapezoidal walls and rounded corners may offer better paste release.

RPP0032B

PACKAGE OUTLINE
VQFN-HR - 1.0 mm max height

PLASTIC QUAD FLAT PACK- NO LEAD

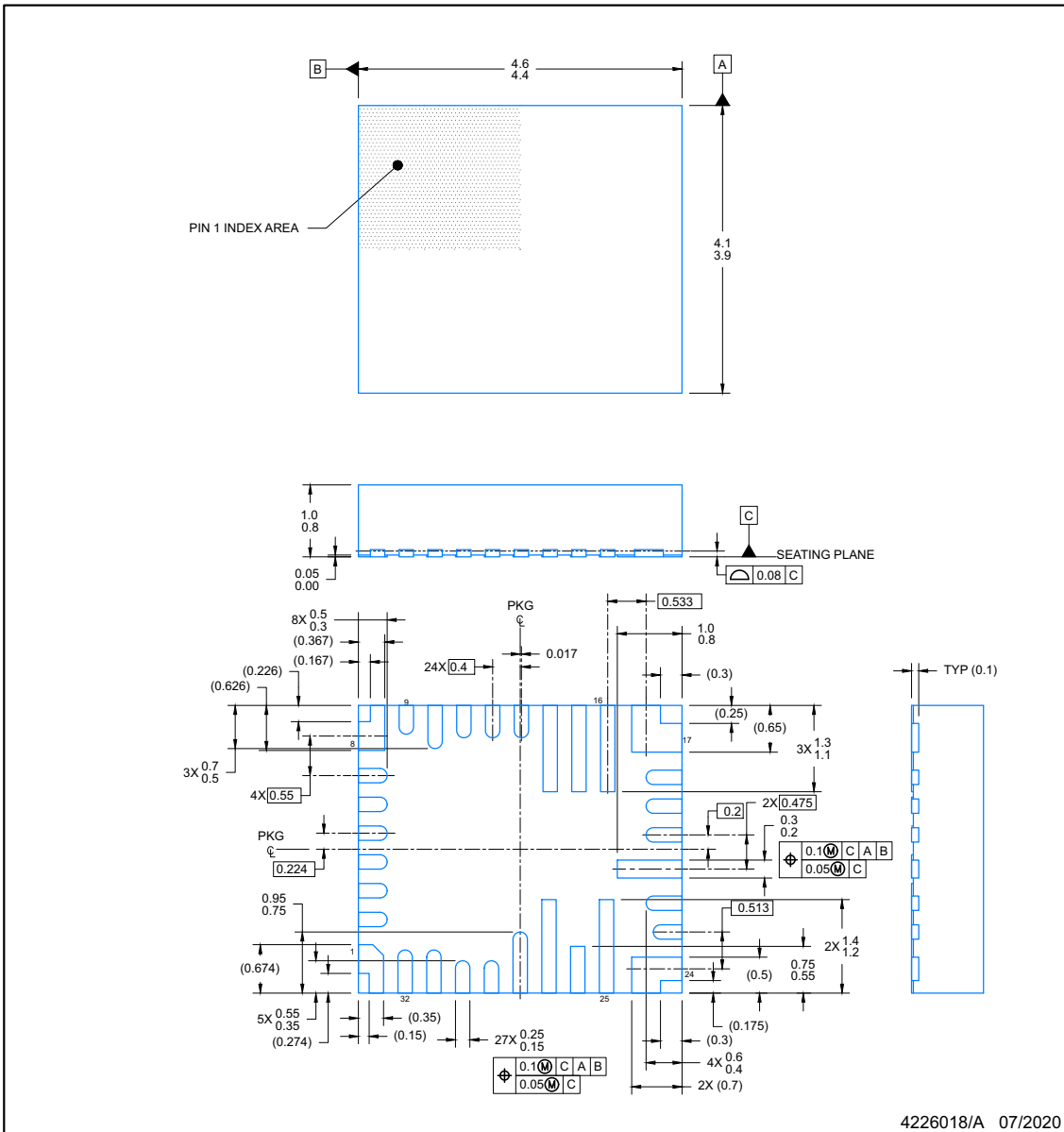

NOTES:

1. All linear dimensions are in millimeters. Any dimensions in parenthesis are for reference only. Dimensioning and tolerancing per ASME Y14.5M.
2. This drawing is subject to change without notice.

EXAMPLE BOARD LAYOUT

VQFN-HR - 1.0 mm max height

RPP0032B

PLASTIC QUAD FLAT PACK- NO LEAD

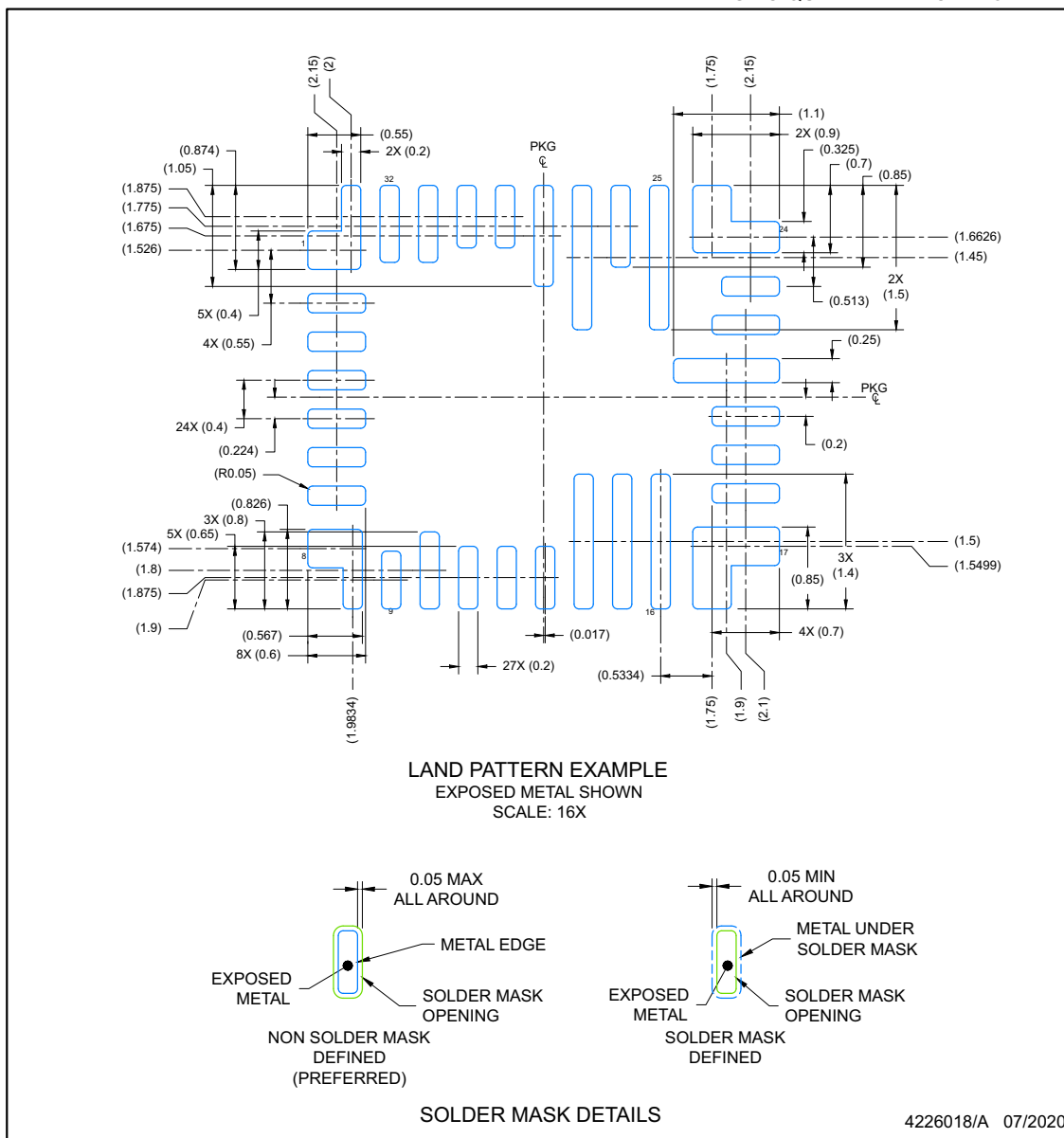

NOTES: (continued)

3. For more information, see Texas Instruments literature number SLUA271 (www.ti.com/lit/slua271) .
4. Solder mask tolerances between and around signal pads can vary based on board fabrication site.

EXAMPLE STENCIL DESIGN

RPP0032B

VQFN-HR - 1.0 mm max height

PLASTIC QUAD FLAT PACK- NO LEAD

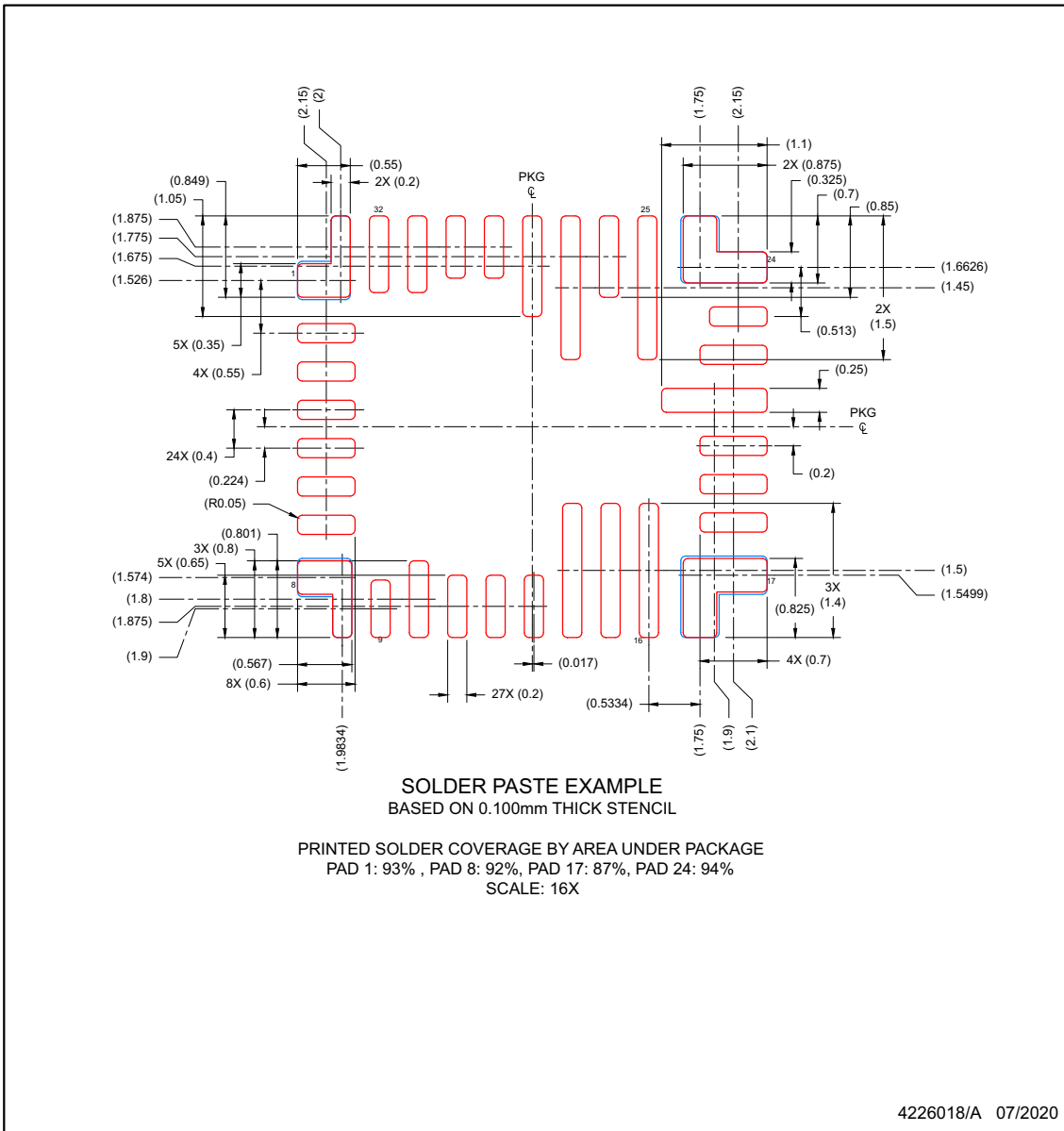

NOTES: (continued)

5. Laser cutting apertures with trapezoidal walls and rounded corners may offer better paste release. IPC-7525 may have alternate design recommendations.

PACKAGING INFORMATION

Orderable Device	Status (1)	Package Type	Package Drawing	Pins	Package Qty	Eco Plan (2)	Lead finish/ Ball material (6)	MSL Peak Temp (3)	Op Temp (°C)	Device Marking (4/5)	Samples
PTAS2563RPPT	ACTIVE	VQFN-HR	RPP	32	250	RoHS & Green	NIPDAU	Level-2-260C-1 YEAR	-40 to 85	TAS2563 P	Samples
TAS2563RPPR	ACTIVE	VQFN-HR	RPP	32	3000	RoHS & Green	Call TI NIPDAU	Level-1-260C-UNLIM	-40 to 85	TAS2X63	Samples
TAS2563RPPT	ACTIVE	VQFN-HR	RPP	32	250	RoHS & Green	Call TI NIPDAU	Level-1-260C-UNLIM	-40 to 85	TAS2X63	Samples
TAS2563YBGR	ACTIVE	DSBGA	YBG	42	3000	RoHS & Green	SNAGCU	Level-1-260C-UNLIM	-40 to 85	TAS2-DSA	Samples
TAS2563YBGT	ACTIVE	DSBGA	YBG	42	250	RoHS & Green	SNAGCU	Level-1-260C-UNLIM	-40 to 85	TAS2-DSA	Samples

(1) The marketing status values are defined as follows:

ACTIVE: Product device recommended for new designs.

LIFEBUY: TI has announced that the device will be discontinued, and a lifetime-buy period is in effect.

NRND: Not recommended for new designs. Device is in production to support existing customers, but TI does not recommend using this part in a new design.

PREVIEW: Device has been announced but is not in production. Samples may or may not be available.

OBSELETE: TI has discontinued the production of the device.

(2) **RoHS:** TI defines "RoHS" to mean semiconductor products that are compliant with the current EU RoHS requirements for all 10 RoHS substances, including the requirement that RoHS substance do not exceed 0.1% by weight in homogeneous materials. Where designed to be soldered at high temperatures, "RoHS" products are suitable for use in specified lead-free processes. TI may reference these types of products as "Pb-Free".

RoHS Exempt: TI defines "RoHS Exempt" to mean products that contain lead but are compliant with EU RoHS pursuant to a specific EU RoHS exemption.

Green: TI defines "Green" to mean the content of Chlorine (Cl) and Bromine (Br) based flame retardants meet JS709B low halogen requirements of <=1000ppm threshold. Antimony trioxide based flame retardants must also meet the <=1000ppm threshold requirement.

(3) MSL, Peak Temp. - The Moisture Sensitivity Level rating according to the JEDEC industry standard classifications, and peak solder temperature.

(4) There may be additional marking, which relates to the logo, the lot trace code information, or the environmental category on the device.

(5) Multiple Device Markings will be inside parentheses. Only one Device Marking contained in parentheses and separated by a "~" will appear on a device. If a line is indented then it is a continuation of the previous line and the two combined represent the entire Device Marking for that device.

(6) Lead finish/Ball material - Orderable Devices may have multiple material finish options. Finish options are separated by a vertical ruled line. Lead finish/Ball material values may wrap to two lines if the finish value exceeds the maximum column width.

Important Information and Disclaimer: The information provided on this page represents TI's knowledge and belief as of the date that it is provided. TI bases its knowledge and belief on information provided by third parties, and makes no representation or warranty as to the accuracy of such information. Efforts are underway to better integrate information from third parties. TI has taken and continues to take reasonable steps to provide representative and accurate information but may not have conducted destructive testing or chemical analysis on incoming materials and chemicals. TI and TI suppliers consider certain information to be proprietary, and thus CAS numbers and other limited information may not be available for release.

In no event shall TI's liability arising out of such information exceed the total purchase price of the TI part(s) at issue in this document sold by TI to Customer on an annual basis.

TAPE AND REEL INFORMATION

QUADRANT ASSIGNMENTS FOR PIN 1 ORIENTATION IN TAPE

*All dimensions are nominal

Device	Package Type	Package Drawing	Pins	SPQ	Reel Diameter (mm)	Reel Width W1 (mm)	A0 (mm)	B0 (mm)	K0 (mm)	P1 (mm)	W (mm)	Pin1 Quadrant
TAS2563RPPR	VQFN-HR	RPP	32	3000	330.0	12.4	4.3	4.8	1.2	8.0	12.0	Q2
TAS2563RPPT	VQFN-HR	RPP	32	250	180.0	12.4	4.3	4.8	1.2	8.0	12.0	Q2
TAS2563YBGR	DSBGA	YBG	42	3000	330.0	12.4	2.71	3.17	0.6	8.0	12.0	Q1
TAS2563YBGT	DSBGA	YBG	42	250	330.0	12.4	2.71	3.17	0.6	8.0	12.0	Q1

TAPE AND REEL BOX DIMENSIONS

*All dimensions are nominal

Device	Package Type	Package Drawing	Pins	SPQ	Length (mm)	Width (mm)	Height (mm)
TAS2563RPPR	VQFN-HR	RPP	32	3000	367.0	367.0	35.0
TAS2563RPPT	VQFN-HR	RPP	32	250	210.0	185.0	35.0
TAS2563YBGR	DSBGA	YBG	42	3000	367.0	367.0	35.0
TAS2563YBGT	DSBGA	YBG	42	250	367.0	367.0	35.0

GENERIC PACKAGE VIEW

RPP 32

VQFN-HR - 1.0 mm max height

4.5 x 4, 0.4 mm pitch

PLASTIC QUAD FLAT PACK- NO LEAD

This image is a representation of the package family, actual package may vary.
Refer to the product data sheet for package details.

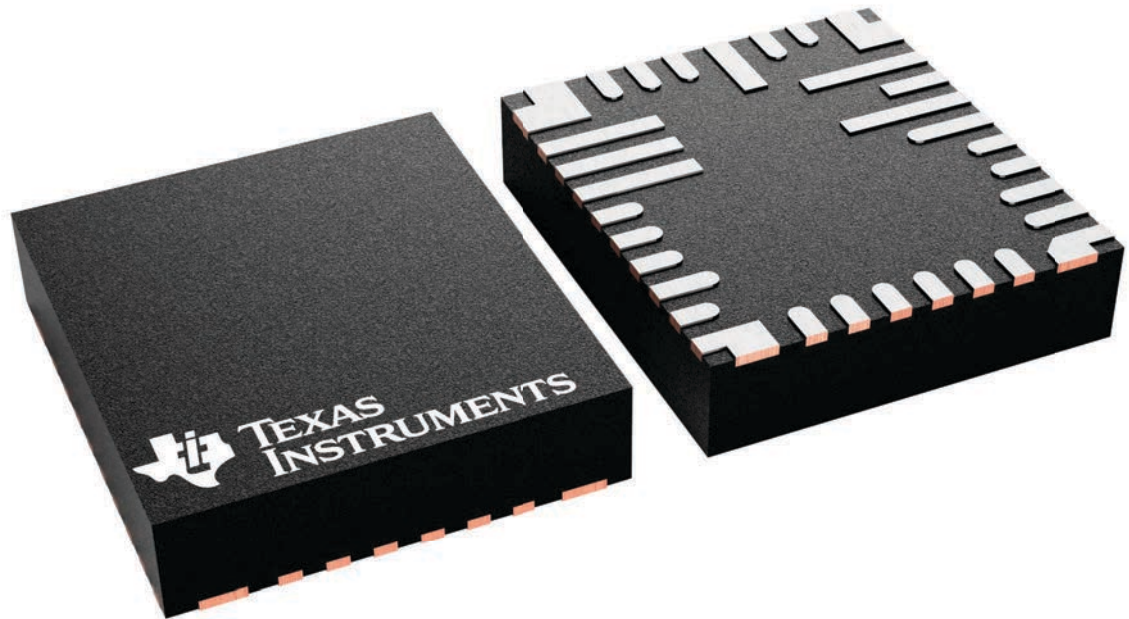

4226439/A

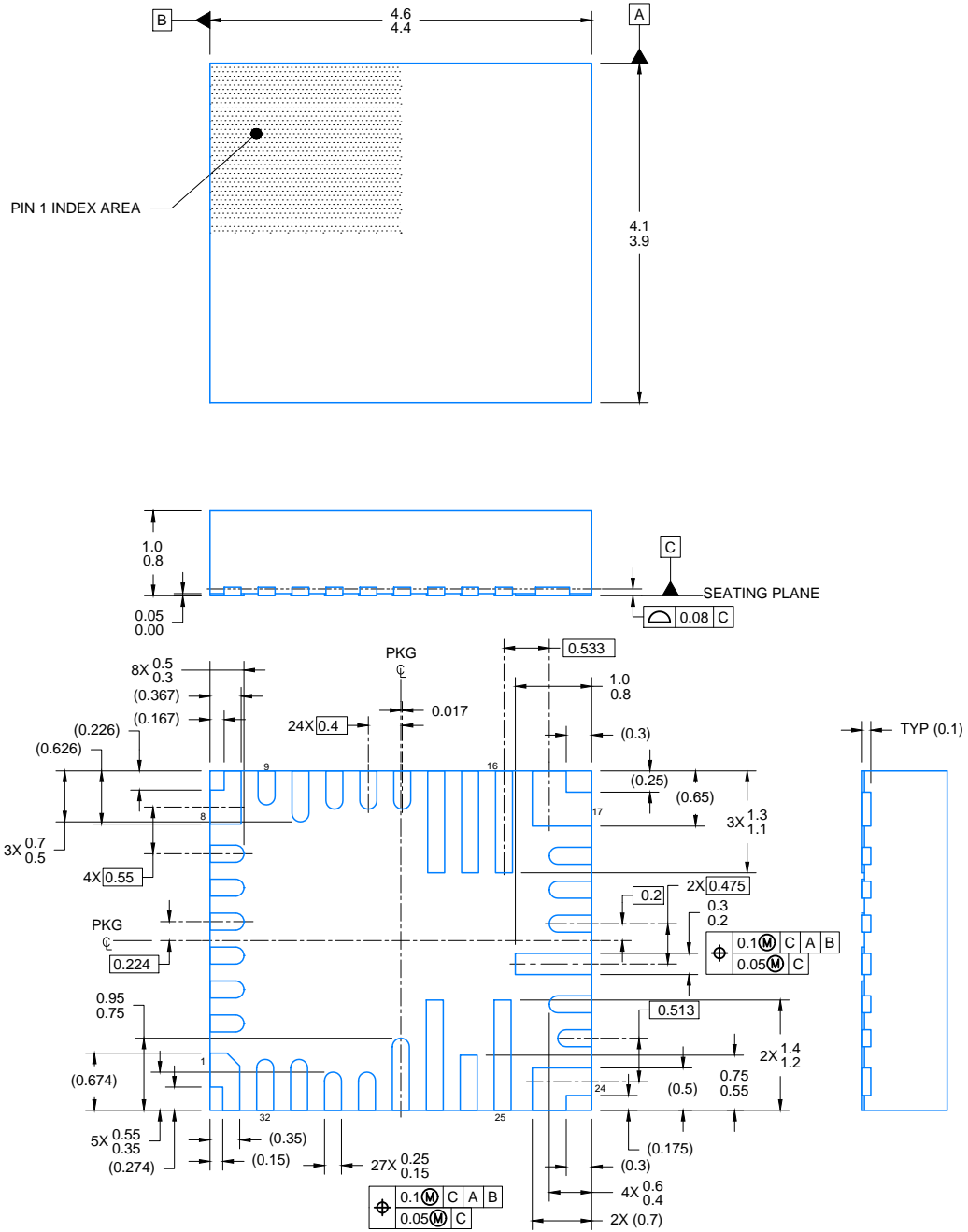

4226018/A 07/2020

NOTES:

1. All linear dimensions are in millimeters. Any dimensions in parenthesis are for reference only. Dimensioning and tolerancing per ASME Y14.5M.
2. This drawing is subject to change without notice.

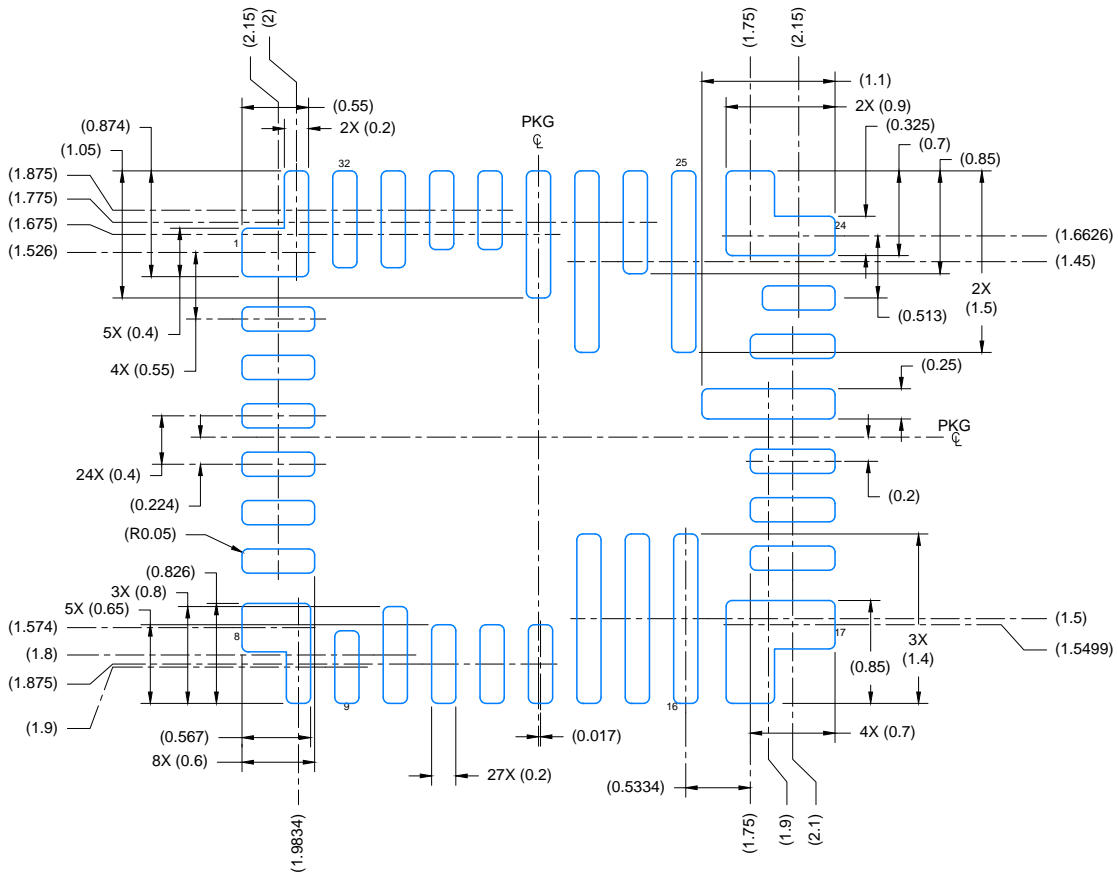

LAND PATTERN EXAMPLE
EXPOSED METAL SHOWN
SCALE: 16X

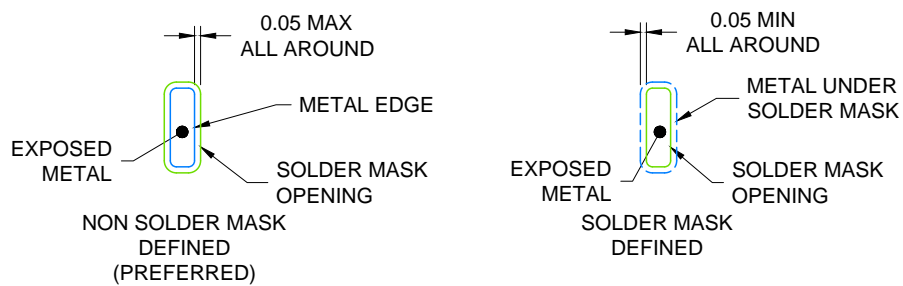

SOLDER MASK DETAILS

4226018/A 07/2020

NOTES: (continued)

3. For more information, see Texas Instruments literature number SLUA271 (www.ti.com/lit/sluea271) .
4. Solder mask tolerances between and around signal pads can vary based on board fabrication site.

EXAMPLE STENCIL DESIGN

RPP0032B

VQFN-HR - 1.0 mm max height

PLASTIC QUAD FLAT PACK- NO LEAD

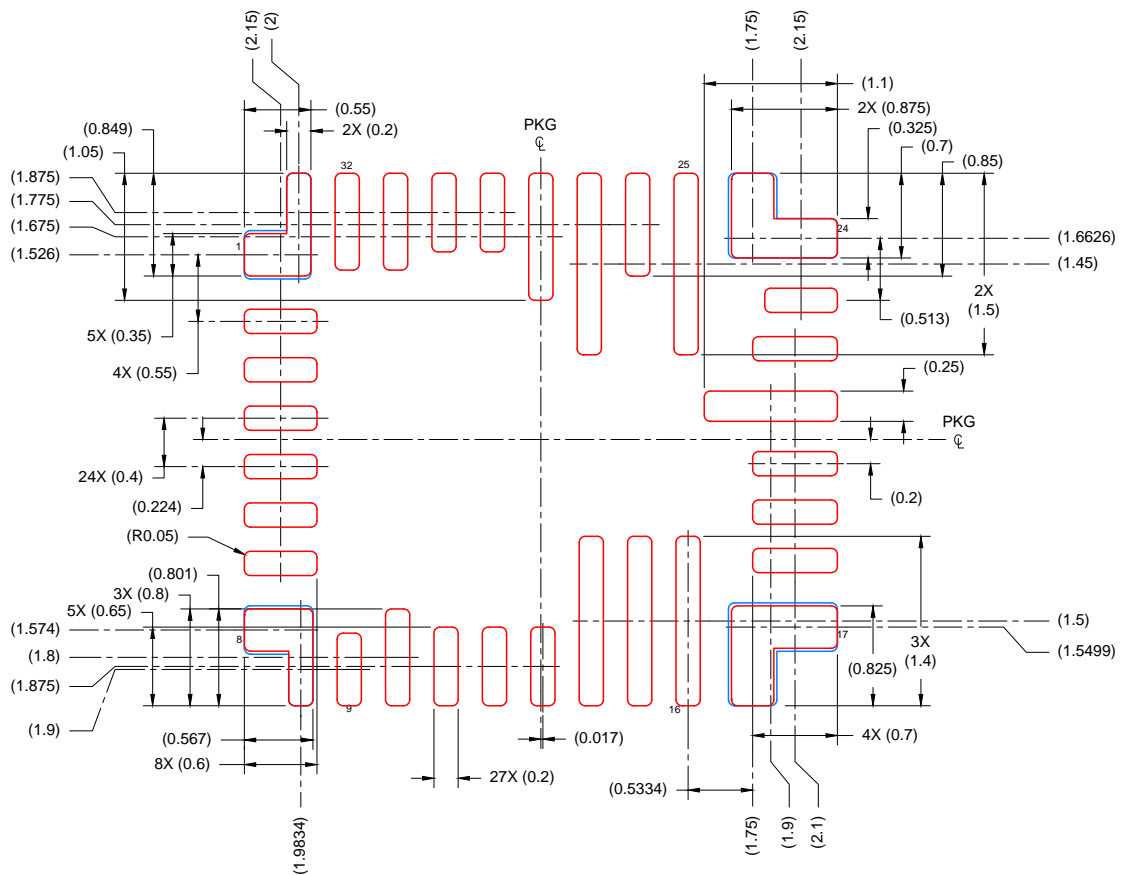

SOLDER PASTE EXAMPLE
BASED ON 0.100mm THICK STENCIL

PRINTED SOLDER COVERAGE BY AREA UNDER PACKAGE
PAD 1: 93% , PAD 8: 92% , PAD 17: 87% , PAD 24: 94%
SCALE: 16X

4226018/A 07/2020

NOTES: (continued)

5. Laser cutting apertures with trapezoidal walls and rounded corners may offer better paste release. IPC-7525 may have alternate design recommendations.

YBG0042

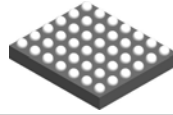

PACKAGE OUTLINE

DSBGA - 0.5 mm max height

DIE SIZE BALL GRID ARRAY

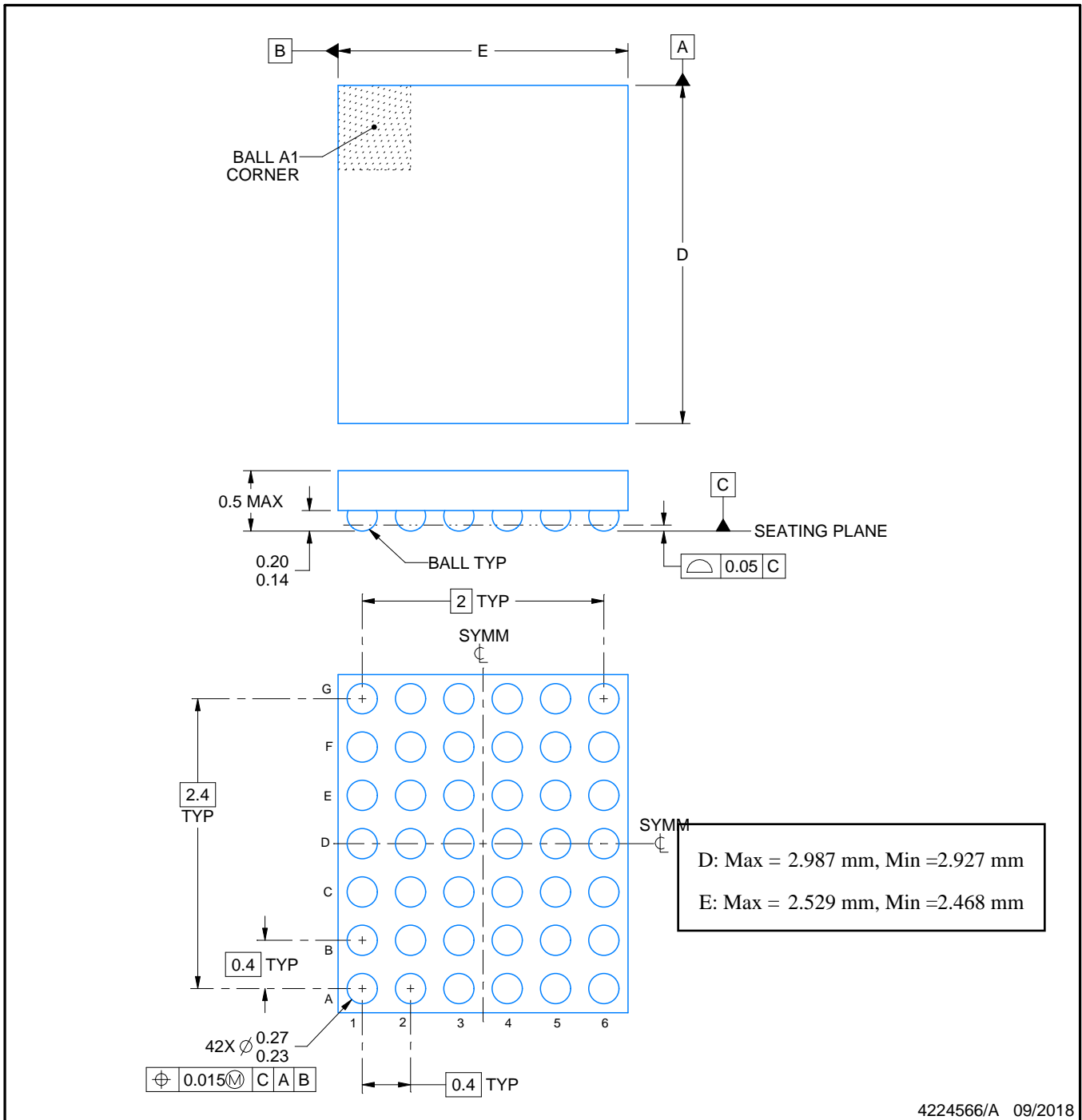

NOTES:

1. All linear dimensions are in millimeters. Any dimensions in parenthesis are for reference only. Dimensioning and tolerancing per ASME Y14.5M.
2. This drawing is subject to change without notice.

EXAMPLE BOARD LAYOUT

YBG0042

DSBGA - 0.5 mm max height

DIE SIZE BALL GRID ARRAY

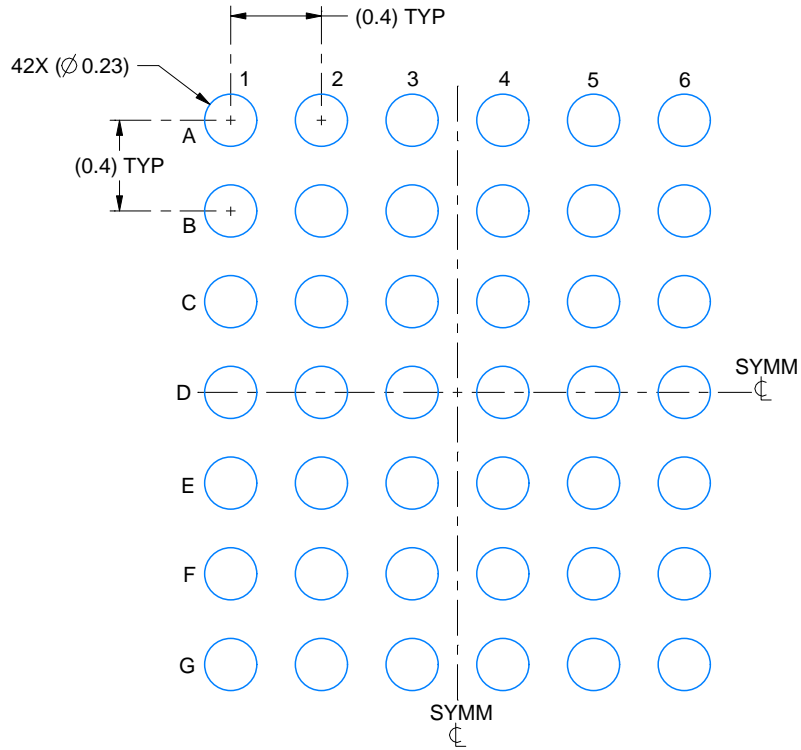

LAND PATTERN EXAMPLE
EXPOSED METAL SHOWN
SCALE: 30X

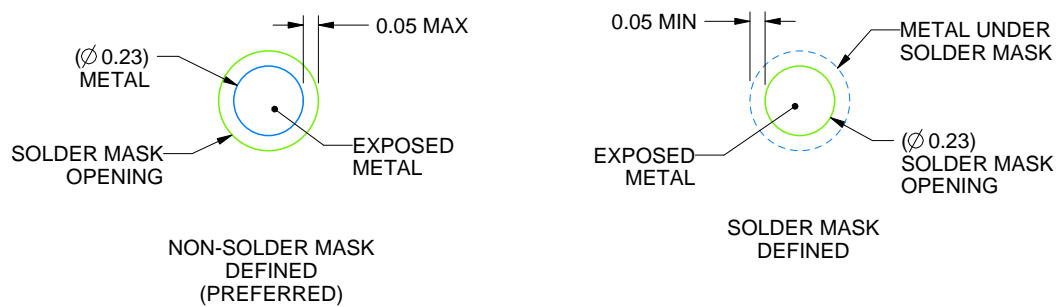

SOLDER MASK DETAILS
NOT TO SCALE

4224566/A 09/2018

NOTES: (continued)

- 3. Final dimensions may vary due to manufacturing tolerance considerations and also routing constraints. See Texas Instruments Literature No. SNVA009 (www.ti.com/lit/snva009).

EXAMPLE STENCIL DESIGN

YBG0042

DSBGA - 0.5 mm max height

DIE SIZE BALL GRID ARRAY

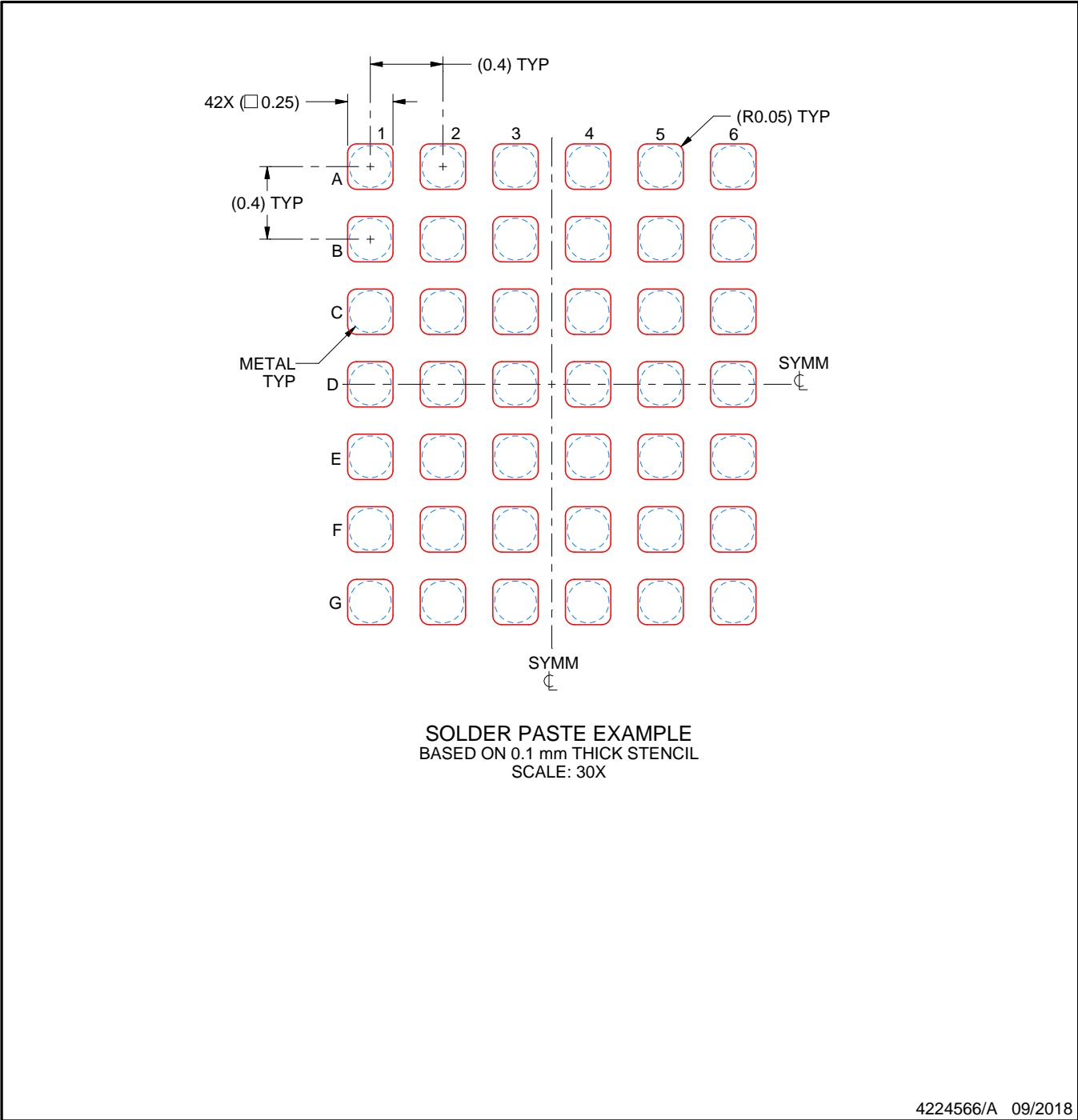

NOTES: (continued)

4. Laser cutting apertures with trapezoidal walls and rounded corners may offer better paste release.

IMPORTANT NOTICE AND DISCLAIMER

TI PROVIDES TECHNICAL AND RELIABILITY DATA (INCLUDING DATASHEETS), DESIGN RESOURCES (INCLUDING REFERENCE DESIGNS), APPLICATION OR OTHER DESIGN ADVICE, WEB TOOLS, SAFETY INFORMATION, AND OTHER RESOURCES "AS IS" AND WITH ALL FAULTS, AND DISCLAIMS ALL WARRANTIES, EXPRESS AND IMPLIED, INCLUDING WITHOUT LIMITATION ANY IMPLIED WARRANTIES OF MERCHANTABILITY, FITNESS FOR A PARTICULAR PURPOSE OR NON-INFRINGEMENT OF THIRD PARTY INTELLECTUAL PROPERTY RIGHTS.

These resources are intended for skilled developers designing with TI products. You are solely responsible for (1) selecting the appropriate TI products for your application, (2) designing, validating and testing your application, and (3) ensuring your application meets applicable standards, and any other safety, security, or other requirements. These resources are subject to change without notice. TI grants you permission to use these resources only for development of an application that uses the TI products described in the resource. Other reproduction and display of these resources is prohibited. No license is granted to any other TI intellectual property right or to any third party intellectual property right. TI disclaims responsibility for, and you will fully indemnify TI and its representatives against, any claims, damages, costs, losses, and liabilities arising out of your use of these resources.

TI's products are provided subject to TI's Terms of Sale (<https://www.ti.com/legal/termsofsale.html>) or other applicable terms available either on [ti.com](https://www.ti.com) or provided in conjunction with such TI products. TI's provision of these resources does not expand or otherwise alter TI's applicable warranties or warranty disclaimers for TI products.

Mailing Address: Texas Instruments, Post Office Box 655303, Dallas, Texas 75265
Copyright © 2021, Texas Instruments Incorporated