

TAS5036

Six Channel Digital Audio PWM Processor

Data Manual

IMPORTANT NOTICE

Texas Instruments Incorporated and its subsidiaries (TI) reserve the right to make corrections, modifications, enhancements, improvements, and other changes to its products and services at any time and to discontinue any product or service without notice. Customers should obtain the latest relevant information before placing orders and should verify that such information is current and complete. All products are sold subject to TI's terms and conditions of sale supplied at the time of order acknowledgment.

TI warrants performance of its hardware products to the specifications applicable at the time of sale in accordance with TI's standard warranty. Testing and other quality control techniques are used to the extent TI deems necessary to support this warranty. Except where mandated by government requirements, testing of all parameters of each product is not necessarily performed.

TI assumes no liability for applications assistance or customer product design. Customers are responsible for their products and applications using TI components. To minimize the risks associated with customer products and applications, customers should provide adequate design and operating safeguards.

TI does not warrant or represent that any license, either express or implied, is granted under any TI patent right, copyright, mask work right, or other TI intellectual property right relating to any combination, machine, or process in which TI products or services are used. Information published by TI regarding third-party products or services does not constitute a license from TI to use such products or services or a warranty or endorsement thereof. Use of such information may require a license from a third party under the patents or other intellectual property of the third party, or a license from TI under the patents or other intellectual property of TI.

Reproduction of information in TI data books or data sheets is permissible only if reproduction is without alteration and is accompanied by all associated warranties, conditions, limitations, and notices. Reproduction of this information with alteration is an unfair and deceptive business practice. TI is not responsible or liable for such altered documentation.

Resale of TI products or services with statements different from or beyond the parameters stated by TI for that product or service voids all express and any implied warranties for the associated TI product or service and is an unfair and deceptive business practice. TI is not responsible or liable for any such statements.

Mailing Address:

Texas Instruments
Post Office Box 655303
Dallas, Texas 75265

Contents

<i>Section</i>	<i>Page</i>
1 Introduction	1
1.1 Features	1
1.2 Functional Block Diagram	2
1.3 Terminal Assignments	3
1.4 Ordering Information	4
1.5 Terminal Functions	4
2 Architecture Overview	6
2.1 Clock and Serial Data Interface	6
2.1.1 Normal-Speed, Double-Speed, and Quad-Speed Selection ..	6
2.1.2 Clock Master/Slave Mode (M_S)	7
2.1.3 Clock Master Mode	7
2.1.4 Clock Slave Mode	8
2.1.5 PLL Filter	10
2.1.6 DCLK	10
2.1.7 Serial Data Interface	10
2.2 Reset, Power Down, and Status	15
2.2.1 Reset—RESET	15
2.2.2 Power Down—PDN	16
2.2.3 Status Registers	16
2.3 Signal Processing	17
2.3.1 Volume Control	17
2.3.2 Mute	18
2.3.3 Auto Mute	18
2.3.4 Individual Channel Mute	18
2.3.5 De-Emphasis Filter	18
2.4 Pulse Width Modulator (PWM)	19
2.4.1 Clipping Indicator	19
2.4.2 Error Recovery	19
2.4.3 Individual Channel Error Re- covery	20
2.4.4 PWM DC-Offset Correction ..	20
2.4.5 Inter-Channel Delay	20
2.4.6 ABD Delay	20
2.4.7 PWM/H-Bridge and Discrete H-Bridge Driver Interface	21
2.5 I2C Serial Control Interface	21
2.5.1 Single Byte Write	22
2.5.2 Multiple Byte Write	22
2.5.3 Single Byte Read	23
2.5.4 Multiple Byte Read	23
3 Serial Control Interface Register Definitions .	24
3.1 General Status Register (x00)	25
3.2 Error Status Register (x01)	25
3.3 System Control Register 0 (x02)	25
3.4 System Control Register 1 (x03)	26
3.5 Error Recovery Register (x04)	26
3.6 Automute Delay Register (x05)	26
3.7 DC-Offset Control Registers (x06–x0B) .	27
3.8 Interchannel Delay Registers (x0C–x11)	27
3.9 ABD Delay Register (x12)	27
3.10 Individual Channel Mute Register (x19) .	27
4 System Initialization	28
5 Specifications	29

5.1	Absolute Maximum Ratings Over Operating Temperature Ranges	29	5.4	Switching Characteristics	30
5.2	Recommended Operating Conditions (Fs = 48 kHz)	29	5.4.1	Command Sequence Timing	30
5.3	Electrical Characteristics Over Recommended Operating Conditions	29	5.4.2	Serial Audio Port	34
5.3.1	Static Digital Specifications Over Recommended Operating Conditions	29	5.4.3	Serial Control Port—I2C Operation	37
5.3.2	Digital Interpolation Filter and PWM Modulator Over Recommended Operating Conditions Fs = 48 kHz	29	6	Application Information	38
5.3.3	TAS5036/TAS5100 System Performance Measured at the Speaker Terminals Over Recommended Operating Conditions	30	6.1	Serial Audio Interface Clock Master and Slave Interface Configuration	39
			6.1.1	Slave Configuration	39
			6.1.2	Master Configuration	39
			Appendix A—Volume Table	41	

List of Illustrations

<i>Figure</i>	<i>Title</i>	<i>Page</i>
2-1	Crystal Circuit	8
2-2	External PLL Loop Filter	10
2-3	I2S 64-Fs Format	11
2-4	I2S 48-Fs Format	12
2-5	Left-Justified 64-Fs Format	12
2-6	Left-Justified 48-Fs Format	13
2-7	Right-Justified 64-Fs Format	13
2-8	Right-Justified 48-Fs Format	14
2-9	DSP Format	14
2-10	Attenuation Curve	17
2-11	De-Emphasis Filter Characteristics	19
2-12	PWM Outputs and H-Bridge Driven in BTL Configuration	21
2-13	Typical I2C Sequence	22
2-14	Single Byte Write Transfer	22
2-15	Multiple Byte Write Transfer	23
2-16	Single Byte Read	23
2-17	Multiple Byte Read	23
4-1	RESET During System Initialization	28
5-1	RESET Timing	30
5-2	Power-Down and Power-Up Timing—RESET Preceding PDN	31
5-3	Power-Down and Power-Up Timing—RESET Following PDN	32
5-4	Error Recovery Timing	33

5-5 Mute Timing	33	5-11 DSP Absolute Timing	36
5-6 Right-Justified, IIS, Left-Justified Serial Protocol Timing	34	5-12 SCL and SDA Timing	37
5-7 Right, Left, and IIS Serial Mode Timing Requirement	35	5-13 Start and Stop Conditions Timing	37
5-8 Serial Audio Ports Master Mode Timing	35	6-1 Typical TAS5036 Application	38
5-9 DSP Serial Port Timing	35	6-2 TAS5036 Serial Audio Port—Slave Mode Connection Diagram	39
5-10 DSP Serial Port Expanded Timing	36	6-3 TAS5036 Serial Audio Port—Master Mode Connection Diagram	39

List of Tables

<i>Table</i>	<i>Title</i>	<i>Page</i>
2-1 Normal-Speed, Double-Speed, and Quad-Speed Operation	3-1 I2C Register Map	24
7	3-2 General Status Register (Read Only)	25
2-2 Master and Slave Clock Modes	3-3 Error Status Register	25
9	3-4 System Control Register 0	25
2-3 LRCLK, MCLK_IN, and External PLL Rates ...	3-5 System Control Register 1	26
9	3-6 Error Recovery Register	26
2-4 DCLK	3-7 Automute Delay Register	26
10	3-8 DC-Offset Control Registers	27
2-5 Supported Word Lengths	3-9 Six Inter-Channel Delay Registers	27
11	3-10 ABD Delay Register	27
2-6 Device Outputs During Reset	3-11 Individual Channel Mute Register	27
15		
2-7 Values Set During Reset		
15		
2-8 Device Outputs During Power Down		
16		
2-9 Volume Register		
18		
2-10 De-Emphasis Filter Characteristics		
18		
2-11 Device Outputs During Error Recovery		
20		

1 Introduction

The TAS5036 is an innovative, cost-effective, high-performance 24-bit six-channel digital pulse width modulator (PWM) based on Equibit™ technology. Combined with a TI digital amplifier power stage, these devices use noise-shaping and sophisticated error correction algorithms to achieve high power efficiency and high-performance digital audio reproduction. The TAS5036 is designed to drive up to six digital power devices to provide six channels of digital audio amplification. The digital power devices can be six conventional monolithic power stages (such as the TAS5110) or six discrete differential power stages using gate drivers and MOSFETs.

The TAS5036 has six independent volume controls and mute. It is designed to drive a digital amplifier power stage (such as the TAS5182) in an H-bridge (bridge tied load) configuration. The device operates in AD and BD modes. This all-digital audio system contains only two analog components in the signal chain—an LC low-pass filter at each speaker terminal and can provide up to 96-dB SNR at the speaker terminals. The TAS5036 has a wide variety of serial input options including right justified (16, 20, or 24 bit), I2S (16, 20, or 24 bit) left justified, or DSP (16-bit) data formats. The device is fully compatible with AES standard sampling rates of 44.1 kHz, 48 kHz, 88.2 kHz, 96 kHz, 176.4 kHz, and 192 kHz including de-emphasis for 44.1-kHz and 48-kHz sample rates. The TAS5036 plus the TAS51xx power stage device combination was designed for home theater applications such as DVD minicomponent systems, home theater in a box (HTIB), DVD receiver, A/V receiver, or TV sets.

1.1 Features

- True Digital Audio Amplifier
- High Quality Audio
 - 96-dB SNR
 - <0.1% THD+N
- Six-Channel Volume Control
 - Patented Soft Volume
 - Patented Soft Mute
- 16-, 20-, or 24-Bit Input Data
- Sampling Rates: 44.1 kHz, 48 kHz, 88.2 kHz, 96 kHz, 176.4 kHz, and 192 kHz
- Supports Master and Slave Modes
- 3.3-V Power Supply Operation
- Economical 80-Pin TQFP Package
- De-Emphasis: 32 kHz, 44.1 kHz, and 48 kHz
- High Power Efficiency
- Clock Oscillator Circuit for Master Modes
- Low Jitter Internal PLL
- Soft Volume and Mute Update
- Excellent PSRR

1.2 Functional Block Diagram

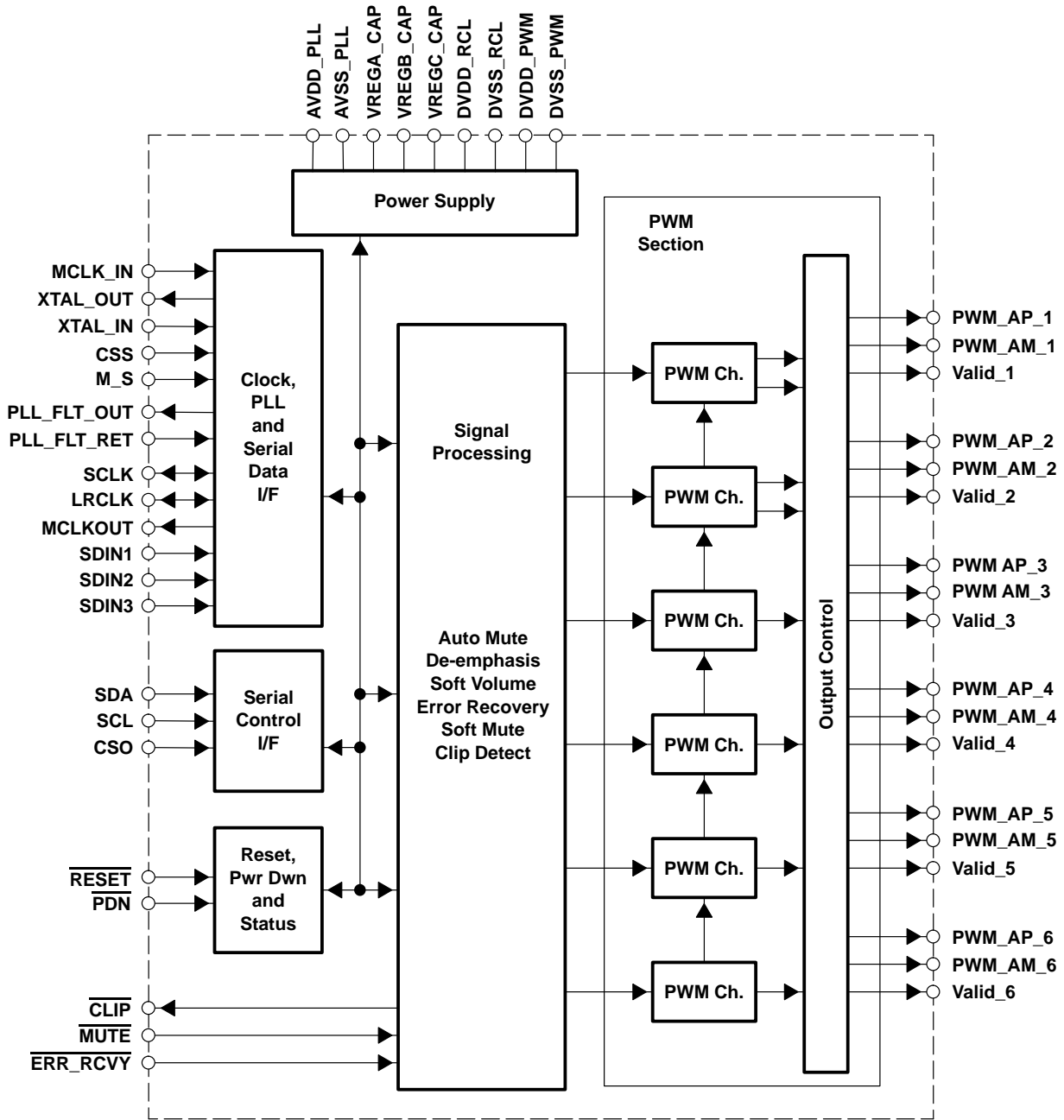

1.3 Terminal Assignments

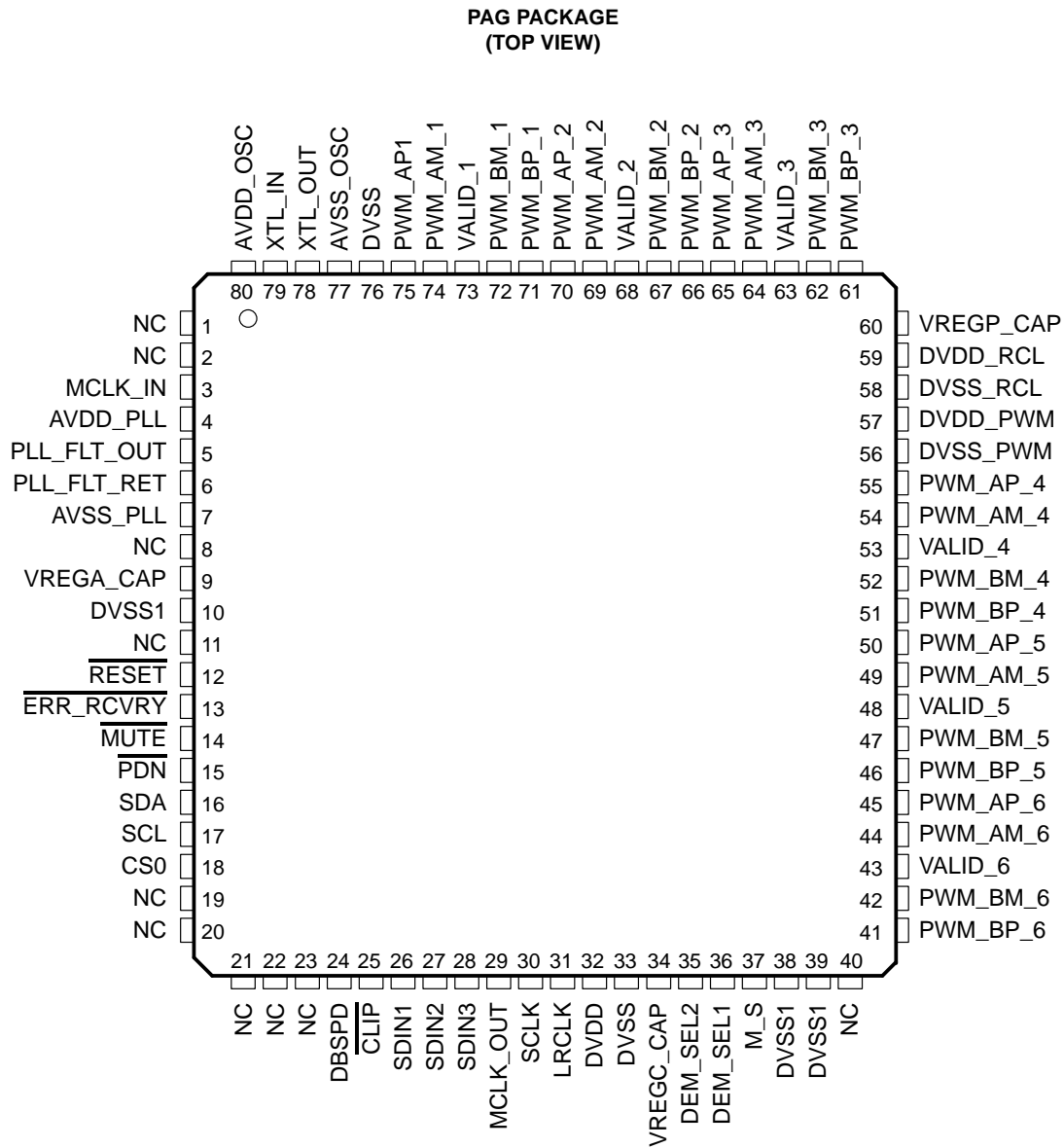

NC – No internal connection

1.4 Ordering Information

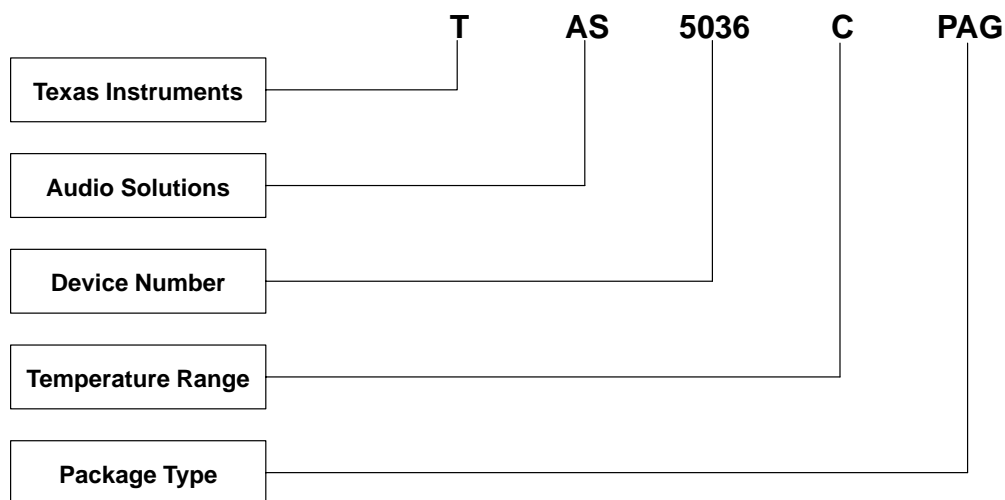

AVAILABLE OPTIONS

T _A	PACKAGE
	PLASTIC 80-PIN TQFP (PAG)
0°C to 70°C	TAS5036CPAG

1.5 Terminal Functions

TERMINAL NAME	NO.	I/O	DESCRIPTION
AVDD_OSC	80	P	Analog power supply for internal oscillator cells
AVDD_PLL	4	P	Analog power supply for PLL
AVSS_OSC	77	AO	Analog ground for internal oscillator cells
AVSS_PLL	7	P	Analog ground for PLL
CLIP	25	DO	Digital clipping indicator, active low
CS0	18	DI	I ² C serial control chip address select input, active high
DBSPD	24	DI	Sample rate is double speed (88.2 kHz or 96 kHz), active high
DM_SEL1	36	DI	De-emphasis select bit 2, 10 = 48 kHz, 11 = undefined (none)
DM_SEL2	35	DI	De-emphasis select bit 1 (0 = none, 01 = 32 kHz, 10 = 44.1 kHz)
DVDD	32	P	Digital power supply
DVDD_PWM	57	P	Digital power supply for PWM
DVDD_RCL	59	P	Digital power supply for reclocker
DVSS	33, 76	P	Digital ground for digital core and most of I/O buffers
DVSS1	10, 38, 39	DIO	Digital ground for digital core and most of I/O buffers
DVSS_PWM	56	P	Digital ground for PWM
DVSS_RCL	58	P	Digital ground for reclocker
ERR_RCVRY	13	DI	Error recovery input, active low
LRCLK	31	DIO	Serial audio data left / right clock (sampling rate clock) (input when M_S = 0; output when M_S = 1)
M_S	37	DI	Master/slave mode input signal (master = 1, slave = 0)
MCLK_IN	3	DI	MCLK input, slave mode (or master / double-speed mode)
MCLK_OUT	29	DO	MCLK output buffered system clock output if M_S = 1; otherwise set to 0
MUTE	14	DI	Mute input signal, active low (muted signal = 0, normal mode = 1)
N/C	1, 2, 8, 11, 19–23, 40		Not connected
PDN	15	DI	Power down, active low

TERMINAL NAME	NO.	I/O	DESCRIPTION
PLL_FLT_OUT	5	AO	PLL external filter
PLL_FLT_RET	6	AO	PLL external filter (internally connected to AVSS_PLL)
PWM_AM_1	74	DO	PWM 1 output (differential -); {positive H-bridge side}
PWM_AM_2	69	DO	PWM 2 output (differential -); {positive H-bridge side}
PWM_AM_3	64	DO	PWM 3 output (differential -); {positive H-bridge side}
PWM_AM_4	54	DO	PWM 4 output (differential -); {positive H-bridge side}
PWM_AM_5	49	DO	PWM 5 output (differential -); {positive H-bridge side}
PWM_AM_6	44	DO	PWM 6 output (differential -); {positive H-bridge side}
PWM_AP_1	75	DO	PWM 1 output (differential +); {positive H-bridge side}
PWM_AP_2	70	DO	PWM 2 output (differential +); {positive H-bridge side}
PWM_AP_3	65	DO	PWM 3 output (differential +); {positive H-bridge side}
PWM_AP_4	55	DO	PWM 4 output (differential +); {positive H-bridge side}
PWM_AP_5	50	DO	PWM 5 output (differential +); {positive H-bridge side}
PWM_AP_6	45	DO	PWM 6 output (differential +); {positive H-bridge side}
PWM_BM_1	72	DO	PWM 1 output (differential -); {negative H-bridge side}
PWM_BM_2	67	DO	PWM 2 output (differential -); {negative H-bridge side}
PWM_BM_3	62	DO	PWM 3 output (differential -); {negative H-bridge side}
PWM_BM_4	52	DO	PWM 4 output (differential -); {negative H-bridge side}
PWM_BM_5	47	DO	PWM 5 output (differential -); {negative H-bridge side}
PWM_BM_6	42	DO	PWM 6 output (differential -); {negative H-bridge side}
PWM_BP_1	71	DO	PWM 1 output (differential +); {negative H-bridge side}
PWM_BP_2	66	DO	PWM 2 output (differential +); {negative H-bridge side}
PWM_BP_3	61	DO	PWM 3 output (differential +); {negative H-bridge side}
PWM_BP_4	51	DO	PWM 4 output (differential +); {negative H-bridge side}
PWM_BP_5	46	DO	PWM 5 output (differential +); {negative H-bridge side}
PWM_BP_6	41	DO	PWM 6 output (differential +); {negative H-bridge side}
RESET	12	DI	System reset input, active low
SCL	17	DI	I ² C serial control clock input
SCLK	30	DIO	Serial audio data clock (shift clock)
SDA	16	DIO	I ² C serial control data input/ output
SDIN1	26	DI	Serial audio data 1 input
SDIN2	27	DI	Serial audio data 2 input
SDIN3	28	DI	Serial audio data 3 input
VALID_1	73	DO	Output indicating validity of PWM outputs, channel 1, active high
VALID_2	68	DO	Output indicating validity of PWM outputs, channel 2, active high
VALID_3	63	DO	Output indicating validity of PWM outputs, channel 3, active high
VALID_4	53	DO	Output indicating validity of PWM outputs, channel 4, active high
VALID_5	48	DO	Output indicating validity of PWM outputs, channel 5, active high
VALID_6	43	DO	Output indicating validity of PWM outputs, channel 6, active high
VREGA_CAP	9	P	C05 voltage regulator capacitor
VREGB_CAP	60	P	C05 voltage regulator capacitor
VREGC_CAP	34	P	C05 voltage regulator capacitor
XTL_IN	79	AI	Crystal or TTL level clock input
XTL_OUT	78	AO	Crystal output (not for external usage)

2 Architecture Overview

The TAS5036 is composed of six functional elements:

- Clock, PLL, and serial data interface (IIS)
- Reset/power down circuitry
- Serial control interface (IIC)
- Signal processing unit
- Pulse width modulator (PWM)
- Power supply

2.1 Clock and Serial Data Interface

The TAS5036 clock and serial data interface contains an input serial data slave and the clock master/ slave interface.

The serial data slave interface receives information from a digital source such as a DSP, S/PDIF receiver, analog-to-digital converter (ADC), digital audio processor (DAP) such as the TAS3103, or other serial bus master at sample rates of for sample rates of 32 kHz, 44.1 kHz, 48 kHz, 88.2 kHz, 96 kHz, 176.4 kHz, and 192 kHz. The serial data interface has three serial data inputs that can accept up to six channels of data. The serial data interfaces support left justified and right justified for 16-, 20-, and 24-bits. In addition, the serial data interfaces support the DSP protocol for 16 bits and the I2S protocol for 24 bits. The received data is data passed to the TAS5036 signal-processing unit.

The TAS5036 can function as a receiver or a generator for the MCLK_IN (master clock), SCLK (shift clock), and LRCLK (left/right clock) signals that control the flow of data on the three serial data interfaces. The TAS5036 is a clock master when it generates these clocks and is a clock slave when it receives these clocks.

The TAS5036 is a synchronous design that relies upon master clock to provide a reference clock for all of the device operations. When operating as a slave, this reference clock is MCLK_IN. When operating as a master, the reference clock is either TTL clock input to XTAL_IN or a crystal attached across XTAL_IN and XTAL_OUT.

If the master clock stops, the TAS5036 will perform a clock error recovery sequence. The clock error recovery sequence temporarily suspends processing, places the PWM outputs in a hard mute (PWM P outputs are low; PWM M outputs are high, and all VALID signals are low), resets all internal processes, sets the volumes to mute, and suspends all I²C operations.

When the master clock is resumed, the TAS5036 exits the clock error recovery sequence by performing a 4.3-ms partial re-initialization, noiselessly restarting the PWM output, and ramping the volume up to the level specified in the volume control registers. The volume update is performed over a 43 ms. interval. The TAS5036 will preserve all control register settings that were set prior to the clock interruption.

Quad-speed mode is used to support sampling rates of 176.4 kHz and 192 kHz. Quad-speed mode is auto detected supported in slave mode and invoked by control in master mode in slave mode. If the device is not in double speed mode, quad-speed mode is automatically detected when MCLK_IN is 128Fs. In master mode, the PWM is placed in quad-speed mode by setting the quad-speed bit in the system control register through the serial control interface.

The clock and serial data interface has two control parameters: data sample rate and clock master or slave.

2.1.1 Normal-Speed, Double-Speed, and Quad-Speed Selection

The sampling rate is selected through a pin (DBSPD) or the serial control register 0 (X02). When a sample rate is selected, the system automatically performs an error recovery sequence and switches to the new sampling rate. As shown in subsequent sections, the sample rate control sets the frequencies of the SCLK and LRCLK in clock slave mode and the output frequencies of SCLK and LRCLK in clock master mode.

The reference clock for the PLL can be provided by either an external clock source (attached to XTAL_IN) or a crystal (connected across terminals XTAL_IN and XTAL_OUT). The external source attached to MCLK_IN is 256 times (128 in quad mode) the data sample rate (Fs). The SCLK frequency is 64 times the data sample rate and the SCLK frequency of 48 times the data sample rate is not supported in the master mode. The LRCLK frequency is the data sample rate.

There are three data rates: normal speed, double speed, and quad speed.

Normal-speed mode supports data rates of 32 kHz, 44.1 kHz, and 48 kHz. Normal speed is supported in the master and slave modes. The PWM is placed in normal speed by setting the DBSPD terminal low or by setting the normal mode bits in the system control register through the serial control interface. Following this operation, the PWM performs an error recovery sequence automatically and operates in the normal speed mode.

Double-speed mode is used to support sampling rates of 88.2 kHz and 96 kHz. Double speed is supported in master and slave modes. The PWM is placed in double speed mode by setting the DBSPD terminal high or by setting the double speed bits in the system control register through the serial control interface. Following this operation, the PWM performs an error recovery sequence automatically and operates in the double speed mode.

Quad-speed mode is used to support sampling rates of 176.4 kHz and 192 kHz. Quad-speed mode is auto detected supported in slave mode and invoked by control in master mode in slave mode. If the device is not in double speed mode, quad-speed mode is automatically detected when MCLK_IN is 128Fs. In master mode, the PWM is placed in quad-speed mode by setting the quad-speed bit in the system control register through the serial control interface.

Table 2–1. Normal-Speed, Double-Speed, and Quad-Speed Operation

QUAD-SPEED CONTROL REGISTER BIT	DBSPD TERMINAL OR CONTROL REGISTER BIT	MODE	SPEED SELECTION
0	0	Master or slave	Normal speed
0	1	Master or slave	Double speed
1	0	Master or slave	Quad speed
0	0	Slave	Quad speed if MCLK_IN = 128Fs
1	1	Master or slave	Error

2.1.2 Clock Master/Slave Mode (M_S)

Clock master and slave mode can be invoked using the M_S (master slave) terminal.

This terminal specifies the default mode that is set immediately following a device RESET. The serial data interface setting permits the clock generation mode to be changed during normal operation.

The transition to master mode occurs:

- Following a RESET when M_S terminal has a logic high applied

The transition to slave mode occurs:

- Following a RESET when M_S terminal has a logic low applied

2.1.3 Clock Master Mode

When M_S = 1 following a RESET, the TAS5036 provides the master clock, SCLK, and LRCLK to the rest of the system. In the master mode, the TAS5036 outputs the audio system clocks MCLK_OUT, SCLK, and LRCLK.

The TAS5036 device generates these clocks plus its internal clocks from the internal phase-locked loop (PLL). The reference clock for the PLL can be provided by either an external clock source (attached to XTAL_IN) or a crystal (connected across terminals XTAL_IN and XTAL_OUT). The external source attached to MCLK_IN is 256 times (128 in quad mode) the data sample rate (Fs). The SCLK frequency is 64 times the data sample rate and the SCLK frequency of 48 times the data sample rate is not supported in the master mode. The LRCLK frequency is the data sample rate.

2.1.3.1 Crystal Type and Circuit

In clock master mode the TAS5036 can derive the MCLKOUT, SCLK, and LRCLK from a crystal. In this case, the TAS5036 uses a parallel-mode fundamental-mode crystal. This crystal is connected to the TAS5036 as shown in Figure 2–1.

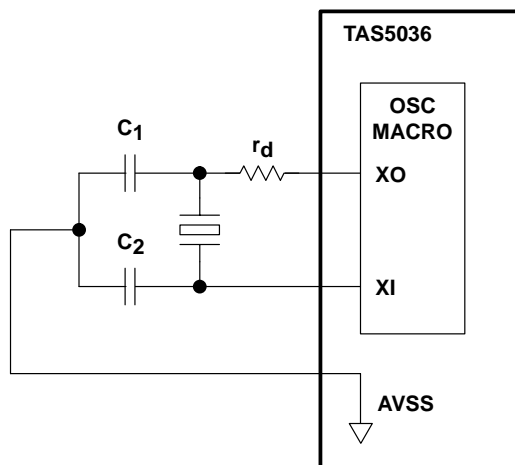

r_d = Drive level control resistor – crystal vendor specified
 C_L = Crystal load capacitance (capacitance of circuitry between the two terminals of the crystal)
 $C_L = (C_1 \times C_2) / (C_1 + C_2) + C_S$ (where C_S = board stray capacitance ~ 3 pF)
 Example: Vendor recommended $C_L = 18$ pF, $C_S = 3$ pF $\geq C_1 = C_2 = 2 \times (18-3) = 30$ pF

Figure 2–1. Crystal Circuit

2.1.4 Clock Slave Mode

In the slave mode ($M_S = 0$), the master clock, LRCLK, and SCLK are inputs to the TAS5036. The master clock is supplied through the MCLK_IN terminal.

As in the master mode, the TAS5036 device developed its internal timing from internal phase-locked loop (PLL). The reference clock for the PLL is provided by the input to the MCLK_IN terminal. This input is at a frequency of 256 times (128 in quad mode) the input data rate. The SCLK frequency is 48 or 64 times the data sample rate. The LRCLK frequency is the data sample rate. The TAS5036 does not require any specific phase relationship between SRCLK and MCLK_IN, but there must be synchronization.

The TAS5036 monitors the relationship between MCLK, SCLK and LRCLK. The TAS5036 will detect if any of the three clocks are absent, if LRCLK rate changes more the ± 10 MCLK cycles since the last device reset or clock error recovery, or if MCLK frequency is changing substantially with respect to the PLL frequency. When a clock error is detected the TAS5036 will perform a clock error recovery sequence. If one or more of the clock signals are absent, the TAS5036 is held with the outputs in hard mute until the clock is resumed. Once the clock is resumed, the clock error recover sequence is completed.

Note. The detection of a clock error causes the TAS5036 to perform an immediate hard mute and suspension of all processes. This abrupt transition can produce a faint click as the outputs are muted.

Since the clocks are removed when changing media or during input selection, it is possible to use this knowledge to completely eliminate clicks in these conditions. In this case, the click is prevented by muting the outputs by using the MUTE terminal or the I²C/MUTE command 43 ms in advance of the clocks being removed.

In slave mode operation, when a crystal is connected to XTAL_IN and XTAL_OUT pins, the internal oscillator of the TAS5036 is turned off.

In the slave mode, MCLK_OUT is driven low.

Table 2–2 shows all the possible master and slave modes. When operating in quad mode ($F_s = 176.4$ kHz or 192 kHz), the device works in slave mode only with $MCLK_IN = 128 F_s$.

Table 2–3 shows the clocks speed for normal, double and quad modes.

Table 2–2. Master and Slave Clock Modes

DESCRIPTION	M_S	DBSPD	XTL_IN (MHz) [†]	MCLK_IN (MHz) [‡]	SCLK (MHz) [¶]	LRCLK (kHz) [¶]	MCLK_OUT (MHz) [#]
Internal PLL, master, normal speed	1	0	8.192	-	2.048	32	8.192
Internal PLL, master, normal speed	1	0	11.2896	-	2.8224	44.1	11.2896
Internal PLL, master, normal speed	1	0	12.288	-	3.072	48	12.288
Internal PLL, master, double speed	1	1	-	22.5792 [§]	5.6448	88.2	22.5792
Internal PLL, master, double speed	1	1	-	24.576 [§]	6.144	96	24.576
Internal PLL, master, quad speed	1	0	-	22.5792	11.2896	176.4	22.5792
Internal PLL, master, quad speed	1	0	-	24.576	12.288	192	24.576
Internal PLL, slave, normal speed	0	0	-	8.192 [§]	2.0484	32	Digital GND
Internal PLL, slave, normal speed	0	0	-	11.2896 [§]	2.8224	44.1	Digital GND
Internal PLL, slave, normal speed	0	0	-	12.288 [§]	3.072	48	Digital GND
Internal PLL, slave, double speed	0	1	-	22.5792	5.6448	88.2	Digital GND
Internal PLL, slave, double speed	0	1	-	24.576 [§]	6.144	96	Digital GND
Internal PLL, slave, quad speed	0	0	-	22.5792 [§]	11.2896	176	Digital GND
Internal PLL, slave, quad speed	0	0	-	24.576 [§]	12.288	192	Digital GND
External PLL, master, normal speed	1	0	-	-	2.048	32	8.192
External PLL, master, normal speed	1	0	-	-	2.8224	44.1	11.2896
External PLL, master, normal speed	1	0	-	-	3.072	48	12.288
External PLL, master, double speed	1	1	-	-	5.6448	88.2	22.5792
External PLL, master, double speed	1	1	-	-	6.144	96	24.576
External PLL, master, quad speed	1	0	-	-	11.2896	176.4	22.5792
External PLL, master, quad speed	1	0	-	-	12.288	192	24.576
External PLL, slave, normal speed	0	0	-	8.192 [§]	2.0484	32	Digital GND
External PLL, slave, normal speed	0	0	-	11.2896 [§]	2.8224	44.1	Digital GND
External PLL, slave, normal speed	0	0	-	12.288 [§]	3.072	48	Digital GND
External PLL, slave, double speed	0	1	-	22.5792	5.6448	88.2	Digital GND
External PLL, slave, double speed	0	1	-	24.576 [§]	6.144	96	Digital GND
External PLL, slave, quad speed	0	0	-	22.5792 [§]	11.2896	176	Digital GND
External PLL, slave, quad speed	0	0	-	24.576 [§]	12.288	192	Digital GND

[†] A crystal oscillator is connected to XTL_IN.

[‡] MCLK_IN tied low when input to XTL_IN is provided; XTL_IN tied low when MCLK_IN_IN is provided.

[§] External MCLK_IN connected to MCLK_IN_IN input

[¶] SCLK and LRCLK are outputs when M_S=1, and inputs when M_S=0.

[#] MCLK_OUT is driven low when M_S=0.

|| Quad-speed mode is detected automatically.

☆ SCLK can be 48 or 64 times Fs

Table 2–3. LRCLK, MCLK_IN, and External PLL Rates

LRCLK	NORMAL SPEED (kHz)				DOUBLE SPEED (kHz)				QUAD SPEED (kHz)		
	1FS	32	44.1	48	1FS	64	88.2	96	1FS	176.4	192
MCLK_IN	256FS	8,192	11,289.6	12,288	256FS	16,384	22,579.2	24,576	128FS	22,579.2	24,576
EXT. PLL	2048FS	65,536	90,316.8	98,304	1024FS	65,536	90,316.8	98,304	512FS	90,316.8	98,304

2.1.5 PLL Filter

A low jitter PLL produces the internal timing of the TAS5036 (when in master mode), the master clock, SCLK, and LRCLK. Connections for the PLL external loop filter are provided through PLL_FLT_OUT and PLL_FLT_RET as shown in Figure 2–2.

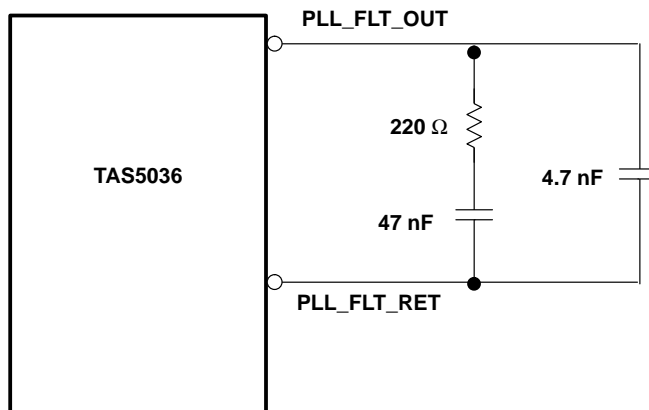

Figure 2–2. External PLL Loop Filter

2.1.6 DCLK

DCLK is the internal high frequency clock that is produced by the PLL circuitry from MCLK. The TAS5036A uses the DCLK to control all internal operations. DCLK is 8 times the speed of MCLK in normal speed mode, 4 times MCLK in double speed, and 2 times MCLK in quad speed. With respect to the I²C addressable registers, DCLK clock cycles are used to specify Interchannel delay and to detect when the MCLK is frequency is drifting. Table 2–4 DCLK shows the relationship between Sample Rate, MCLK and DCLK.

Table 2–4. DCLK

FS (kHz)	MCLK (MHz)	DCLK (MHz)	DCK Period (ns)
32	8.1920	65.5360	15.3
44.1	11.2896	90.3168	11.1
48	12.2880	98.3040	10.2
88	22.5280	90.1120	11.1
96	24.5760	98.3040	10.2
192	49.1520	98.3040	10.2

2.1.7 Serial Data Interface

The TAS5036 operates as a slave only/receive only serial data interface in all modes. The TAS5036 has three PCM serial data interfaces to accept six channels of digital data through the SDIN1, SDIN2, SDIN3 inputs. The serial audio data is in MSB first; 2s complement format.

The serial data interfaces of the TAS5036 can be configured in right justified, I²S, left-justified, or DSP modes. This interface supports 32-kHz, 44.1-kHz, 48-kHz, 88-kHz, 96-kHz, 176.4-kHz, and 192-kHz data sample rates. The serial data interface format is specified using the data interface control register. The supported word lengths are shown in Table 2–5.

During normal operating conditions if the serial data interface settings change state, an error recovery sequence is initiated.

Table 2–5. Supported Word Lengths

DATA MODES	WORD LENGTHS	MOD2	MOD1	MOD0
Right justified, MSB first	16	0	0	0
Right justified, MSB first	20	0	0	1
Right justified, MSB first	24	0	1	0
I ² S	16	0	1	1
I ² S	20	1	0	0
I ² S	24	1	0	1
Left justified, MSB first	24	1	1	0
DSP frame	16	1	1	1

2.1.7.1 I²S Timing

I²S timing uses an LRCLK to define when the data being transmitted is for the left channel or the right channel. The LRCLK is low for the left channel and high for the right channel. A bit clock running at 48 or 64 times F_s is used to clock in the data. There is a delay of one bit clock from the time the LRCLK signal changes state to the first bit of data on the data lines. The data is written MSB first and is valid on the rising edge of the bit clock. The TAS5036 masks unused trailing data bit positions. Master mode only supports a 64 times F_s bit clock.

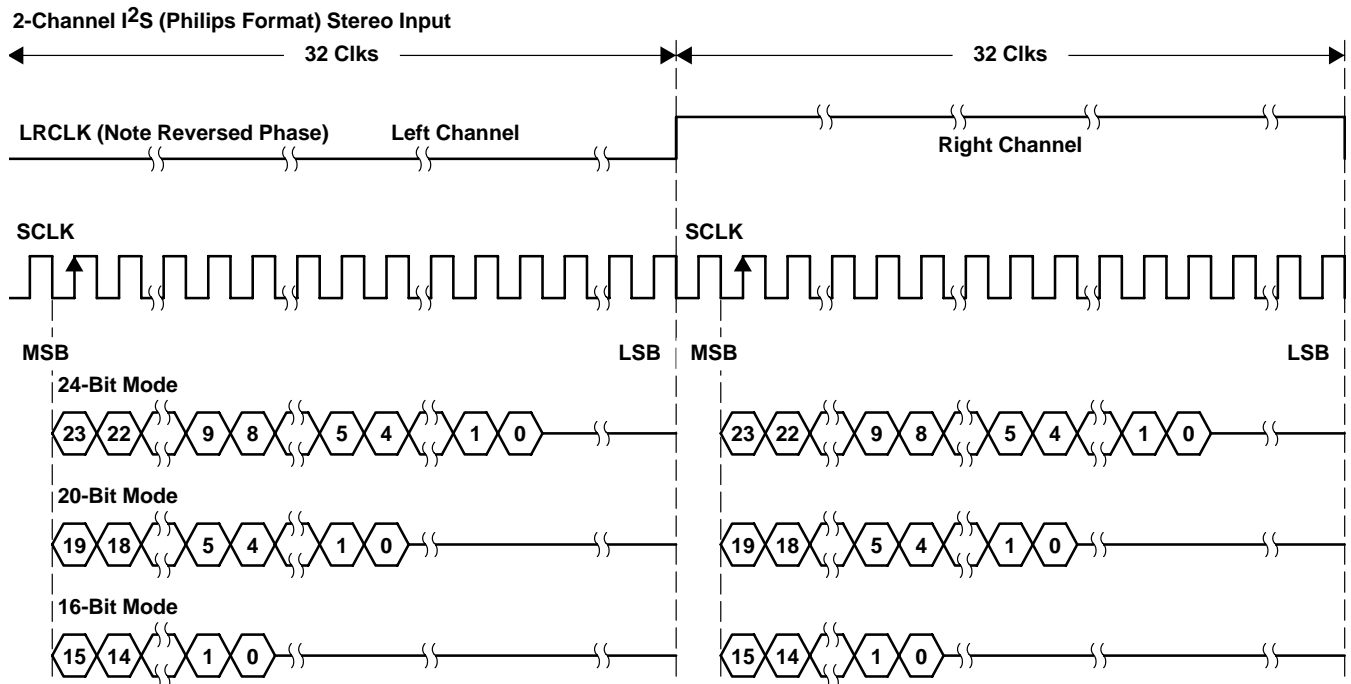
Figure 2–3. I²S 64- F_s Format

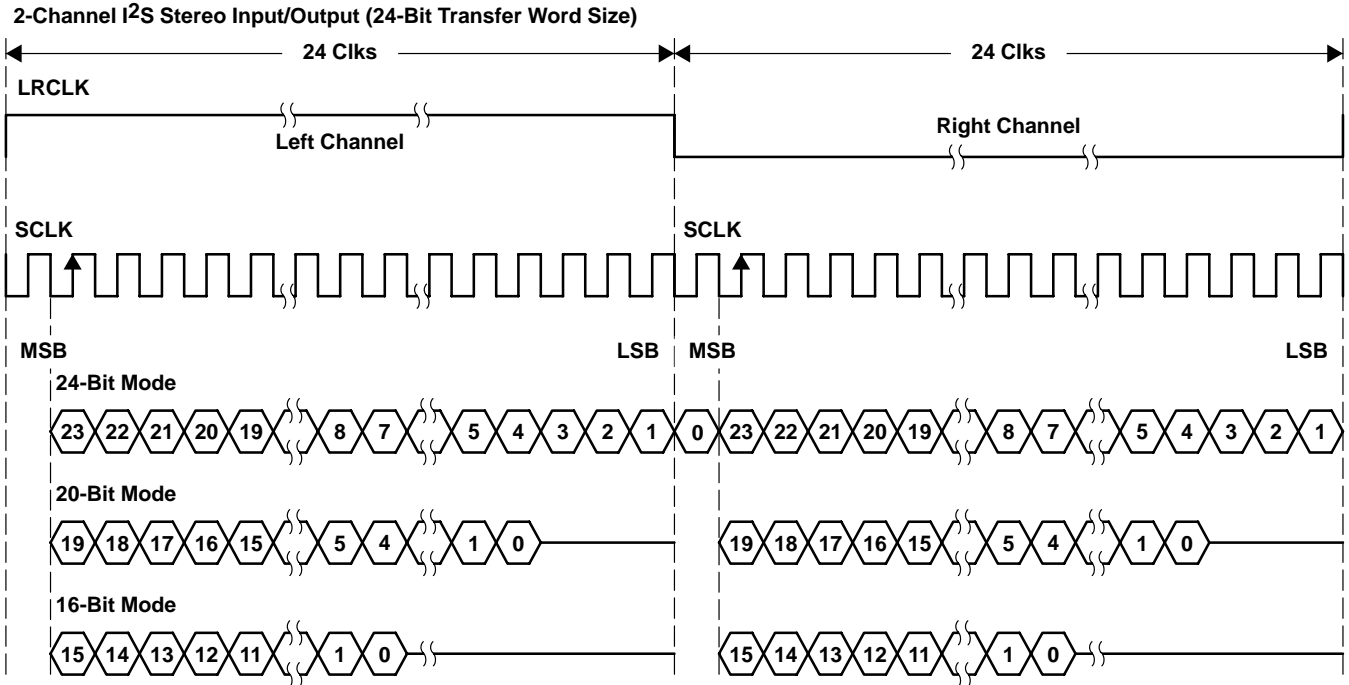
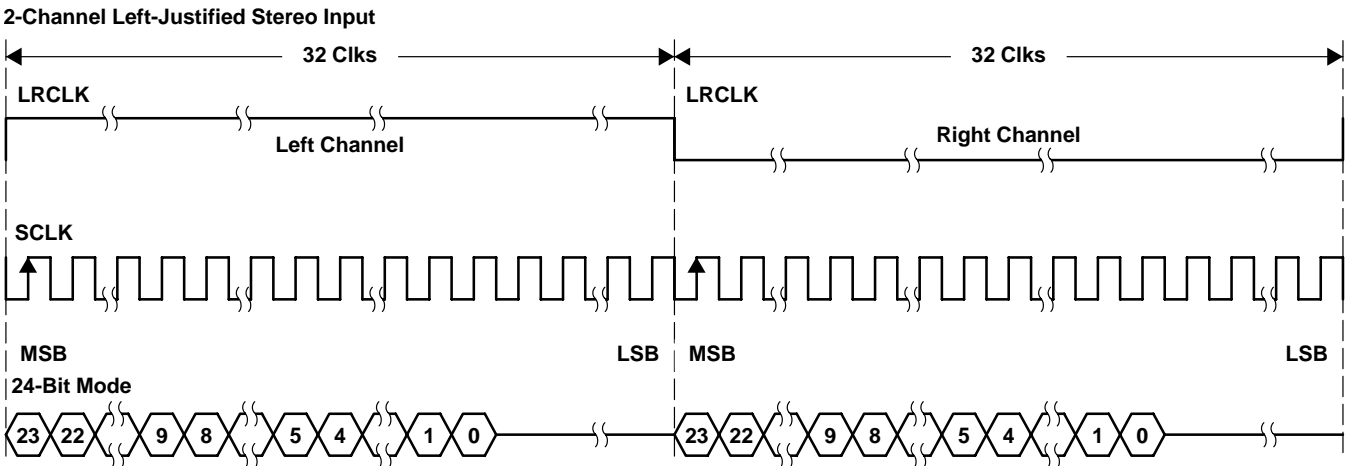

Figure 2–4. I²S 48-Fs Format

2.1.7.2 Left-Justified Timing

Left-justified (LJ) timing uses an LRCLK to define when the data being transmitted is for the left channel and the right channel. The LRCLK is high for the left channel and low for the right channel. A bit clock running at 48 or 64 times F_s is used to clock in the data. The first bit of data appears on the data lines at the same time the LRCLK toggles. The data is written MSB first and is valid on the rising edge of the bit clock. The TAS5036 masks unused trailing data bit positions. Master mode only supports a 64 times F_s bit clock.



NOTE: All data presented in 2s complement form with MSB first.

Figure 2–5. Left-Justified 64-Fs Format

2-Channel Left-Justified Stereo Input/Output (24-Bit Transfer Word Size)

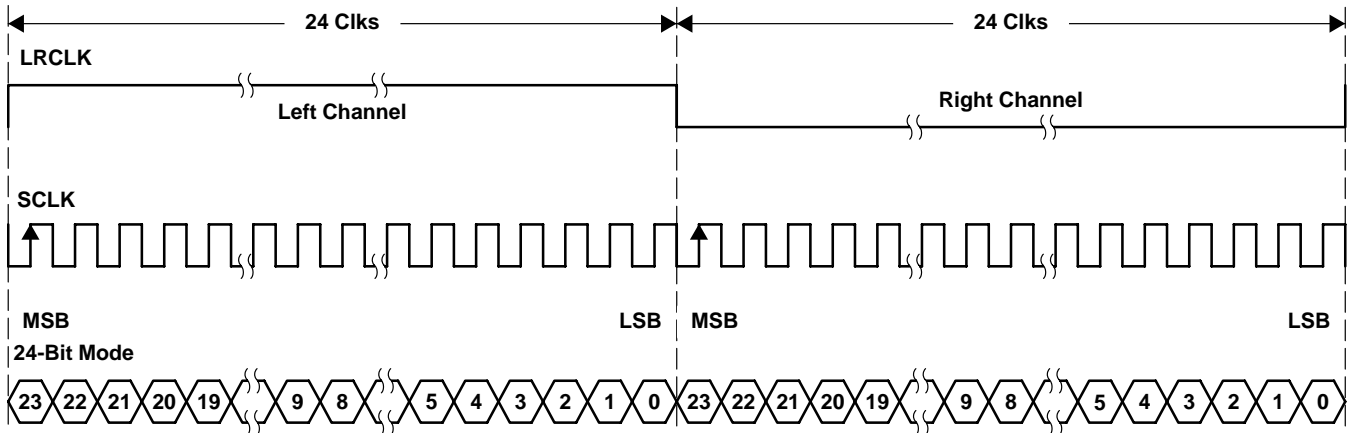
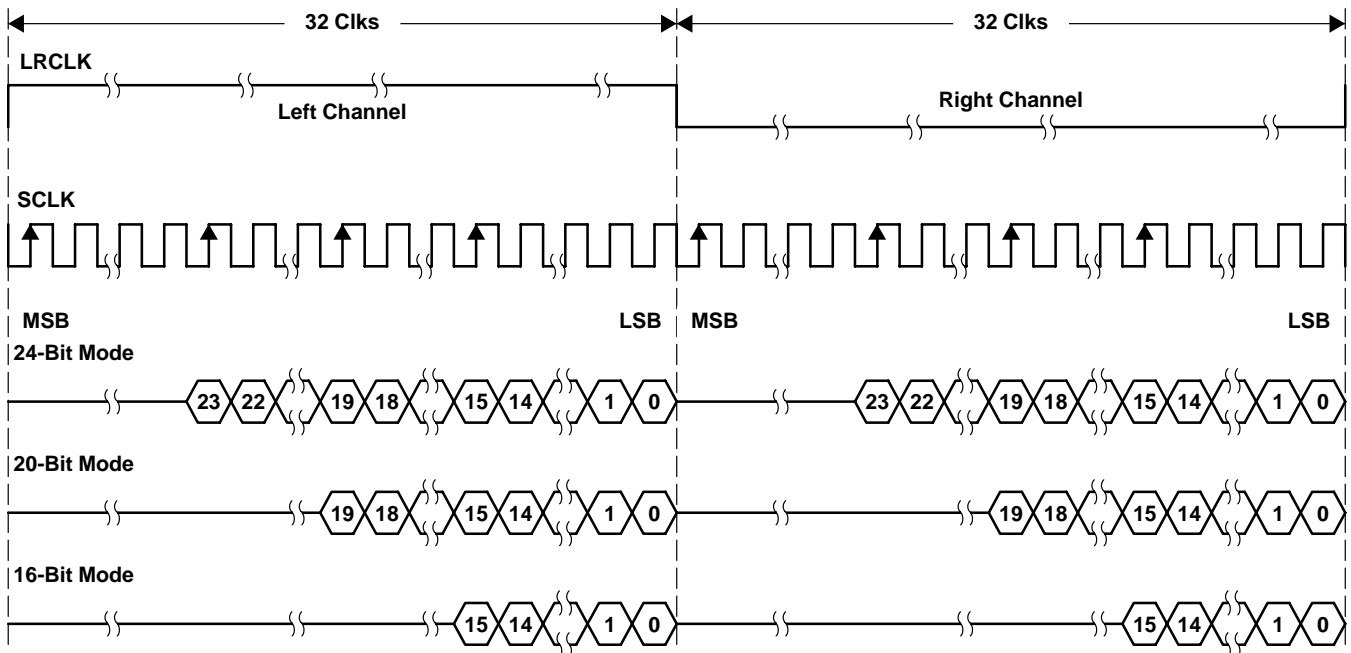

Figure 2–6. Left-Justified 48-Fs Format

2.1.7.3 Right-Justified Timing

Right-justified (RJ) timing uses an LRCLK to define when the data being transmitted is for the left channel and the right channel. The LRCLK is high for the left channel and low for the right channel. A bit clock running at 48 or 64 times F_s is used to clock in the data. The first bit of data appears on the data 8-bit clock periods (for 24-bit data) after LRCLK toggles. In RJ mode, the last bit clock before LRCLK transitions always clocks the LSB of data. The data is written MSB first and is valid on the rising edge of bit clock. The TAS5036 masks unused leading data bit positions. Master mode only supports a 64 times F_s bit clock.

2-Channel Right-Justified (Sony Format) Stereo Input



NOTE: All data presented in 2s complement form with MSB first.

Figure 2–7. Right-Justified 64-Fs Format

2-Channel Right-Justified Stereo Input/Output (24-Bit Transfer Word Size)

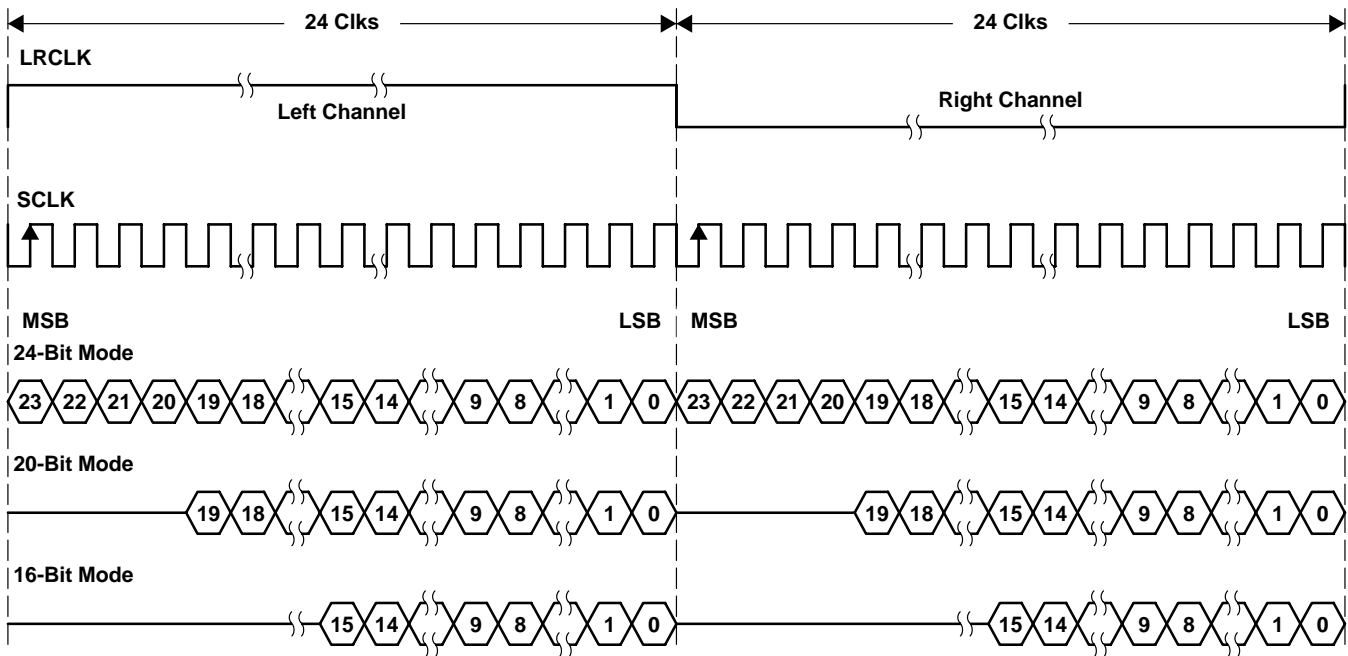

NOTE: All data presented in 2s complement form with MSB first.

Figure 2–8. Right-Justified 48-Fs Format

2.1.7.4 DSP Mode Timing

DSP mode timing uses an LRCLK to define when data is to be transmitted for both channels. A bit clock running at $64 \times F_s$ is used to clock in the data. The first bit of the left channel data appears on the data lines following the LRCLK transition. The data is written MSB first and is valid on the rising edge of the bit clock. The TAS5036 masks unused trailing data bit positions.

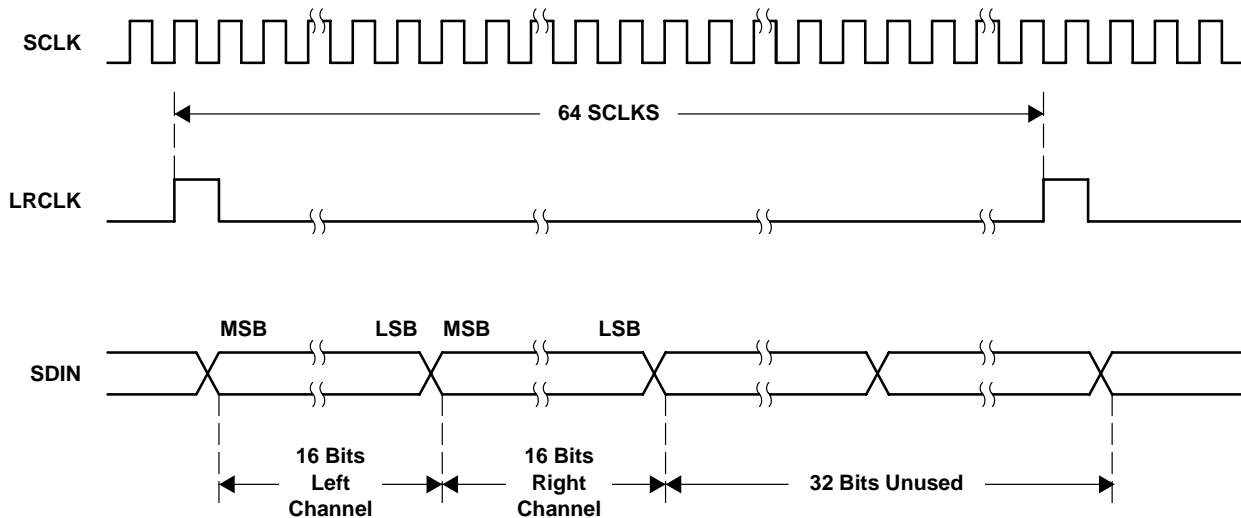

Figure 2–9. DSP Format

2.2 Reset, Power Down, and Status

The reset, power down, and status circuitry provides the necessary controls to bring the TAS5036 to the initial inactive condition, achieve low power standby, and report system status.

2.2.1 Reset— $\overline{\text{RESET}}$

The TAS5036 is placed in the reset mode by setting the $\overline{\text{RESET}}$ terminal low.

$\overline{\text{RESET}}$ is an asynchronous control signal that restores the TAS5036 to its default conditions, sets the valid 1–6 outputs low, and places the PWM in the hard mute state. Volume is immediately set to full attenuation (there is no ramp down).

As long as the $\overline{\text{RESET}}$ terminal is held low, the device is in the reset state. During reset, all I²C and serial data bus operations are ignored. Table 2–6 shows the device output signals while $\overline{\text{RESET}}$ is active.

Upon the release of $\overline{\text{RESET}}$, if POWER_DWN is high, the system performs a 4-ms to 5-ms device initialization and then ramps the volume up to 0 db using a soft volume update sequence. If MCLK_IN is not active when RESET is released high, then a 4-ms to 5-ms initialization sequence is produced once MCLK_IN becomes active.

During device initialization all controls are reset to their initial states. Table 2–7 shows the control settings that are changed during initialization.

$\overline{\text{RESET}}$ should be applied during power-up initialization or while changing the master slave clock states.

Table 2–6. Device Outputs During Reset

SIGNAL	MODE	SIGNAL STATE
Valid 1–Valid 6	All	Low
PWM P-outputs	All	Low
PWM M-outputs	All	Low
MCLKOUT	All	Low
SCLK	Master	Low
SCLK	Slave	Signal input
LRCLK	Master	Low
LRCLK	Slave	Signal input
SDA	All	Signal input
CLIP	All	High

Because the $\overline{\text{RESET}}$ is an asynchronous control signal, small clicks and pops can be produced during the application (the leading edge) of this control. However, when $\overline{\text{RESET}}$ is released, the transition from the hard mute state back to normal operation is performed synchronously using a quiet sequence.

If a completely quiet reset sequence is desired, $\overline{\text{MUTE}}$ should be applied before applying $\overline{\text{RESET}}$.

Table 2–7. Values Set During Reset

CONTROL	SETTING
Volume	0 dB
MCLK_IN frequency	256
Master/slave mode	M_S terminal state
Auto mute	Enabled
De-emphasis	None
DC offset	0
Interchannel delay	Each channel set at 16 clocks higher than preceding channel

2.2.2 Power Down— $\overline{\text{PDN}}$

The TAS5036 can be placed into the power-down mode by holding the $\overline{\text{PDN}}$ terminal low. When power-down mode is entered, both the PLL and the oscillator are shut down. Volume is immediately set to full attenuation (there is no ramp down). The valid 1–6 outputs are immediately asserted low and the PWM outputs are placed in the hard mute state. $\overline{\text{PDN}}$ initiates device power down without clock inputs. As long as the $\overline{\text{PDN}}$ terminal is held low—the device is in the power-down (hard mute) state.

During power down, all I²C and serial data bus operations are ignored. Table 2–8 shows the device output signals while $\overline{\text{PDN}}$ is active.

Table 2–8. Device Outputs During Power Down

SIGNAL	MODE	SIGNAL STATE
Valid 1–Valid 6	All	Low
PWM P-outputs	All	Low
PWM M-outputs	All	Low
MCLKOUT	All	Low
SCLK	Master	Low
SCLK	Slave	Signal input
LRCLK	Master	Low
LRCLK	Slave	Signal input
SDA	All	Signal input
$\overline{\text{CLIP}}$	All	High

To place the device in total power-down mode, both RESET and power-down modes must be enabled. Prior to bringing $\overline{\text{PDN}}$ high, $\overline{\text{RESET}}$ must be brought low for a minimum of 50 ns.

Because $\overline{\text{PDN}}$ is an asynchronous control signal, small clicks and pops can be produced during the application (the leading edge) of this control. However, when $\overline{\text{PDN}}$ is released, the transition from the hard mute state back to normal operation is performed synchronously using a quiet sequence.

If a completely quiet reset sequence is desired, $\overline{\text{MUTE}}$ should be applied before applying $\overline{\text{PDN}}$.

2.2.2.1 Recovery Time Options

To support the requirements of various system configurations, the TAS5036 can come up to the normal state after either a long (100 ms) or a short (5 ms) delay.

1. In the first case, a slow system (95 ms to 100 ms) start-up occurs at the end of the power-down sequence when:

$\overline{\text{RESET}}$ is high for at least 16 MCLK_IN periods before $\overline{\text{PDN}}$ goes high.

2. Otherwise a fast (4 ms to 5 ms) start up occurs.

NOTE: If MCLK_IN is not active when both of these signals are released high, then a fast (4 ms to 5 ms) start up occurs once MCLK_IN becomes active.

2.2.3 Status Registers

The TAS5036 provides device identification and operational status information that is accessible through the serial control interface status registers that provide general device information.

Device ID—The TAS5036 provides a device identification code that is accessible through the serial control interface

Volume Update is in Progress—Whenever a volume change is in progress, this status bit is high.

No Internal Errors (All Valid Signals are High)—When there are no internal errors in the TAS5036 and all outputs are valid, this status bit is high.

LRCLK Error—When there are the MCLK_IN rate changes more than ± 10 MCLK_IN cycles from the correct number of cycles (128 or 256) per LRCLK cycle

MCLK_IN Error—When the MCLK_IN frequency changes such that it is out of synchronization with internal PLL generated clock

2.3 Signal Processing

This section contains the signal processing functions that are contained in the TAS5036. The signal processing is performed using a high-speed 24-bit signal processing architecture. The TAS5036 performs the following signal processing features:

- Individual channel soft volume with a range of 24 dB to –114 dB plus mute
- Soft mute
- Auto mute
- 50- μ s/15- μ s de-emphasis filter supported in the sampling rates 32 kHz, 44.1 kHz, and 48 kHz

2.3.1 Volume Control

The gain of each output can be adjusted by a soft digital volume control for each channel. Volume adjustments are performed using a soft gain update s-curve, which is approximated using a second order filter fit. The curve fit is performed over a transition interval between 41 ms and 65 ms.

The volume of each channel can be adjusted from mute to 24 dB to –114 dB in 0.5 dB steps. Because of the numerical representation that is used to control the volume, at very low volume levels the step size increases for gains of that are less than –96 dB. The default volume setting following power up or reset is 0 dB for all channels. The step size increases linearly up to approximately –90 dB, see Figure 2–10.

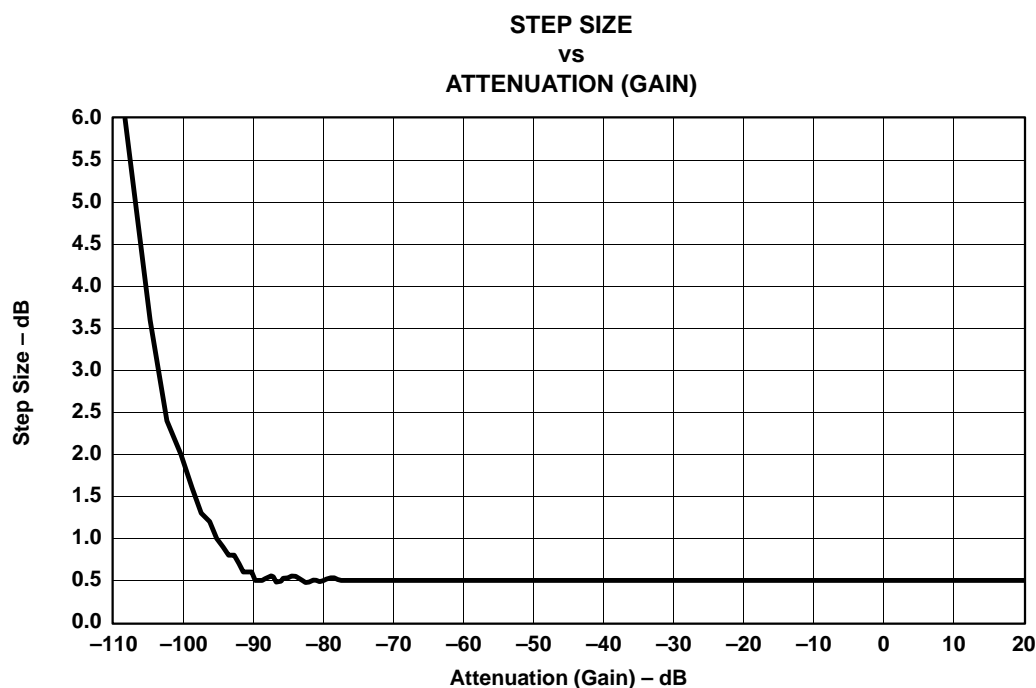

Figure 2–10. Attenuation Curve

The volume control format for each channel is expressed in 8 bits. The volume for each channel is set by writing 8 bits via the serial control interface. The MSB bit is written first as in the bit position 0 (LSB position).

The volume for each channel can be set using a single or multiple address write operation to the volume control register via the serial control interface. To change the volume of all six channels requires that 6 registers be updated.

To coordinate the volume adjustment of multiple channels simultaneously, the TAS5036 performs a delayed volume update upon receiving a volume change command. Following the completion of the register volume write operations, the TAS5036 waits for 5 ms for another volume command to be given. If no volume command is issued in that period of time, the TAS5036 starts adjusting the volume of the channels that received volume settings.

While a volume update is being performed, the system status register indicates that the update is in progress. During the update, all subsequent volume control setting requests that are sent to the TAS5036 are received and stored as a single next value for a subsequent update. If more than one volume setting request is sent, only the last is retained.

Table 2–9. Volume Register

VOLUME REGISTER							
D 7	D 6	D 5	D 4	D 3	D 2	D 1	D 0
Vol Bit 7	Vol Bit 6	Vol Bit 5	Vol Bit 4	Vol Bit 3	Vol Bit 2	Vol Bit 1	Vol Bit 0

2.3.2 Mute

The application of mute ramps the volume from any setting to noiseless hard mute state. There are two methods in which the TAS5036 can be placed into mute. The TAS5036 is placed in the noiseless mute when the $\overline{\text{MUTE}}$ terminal is asserted low for a minimum of 3 MCLK_IN cycles. Alternatively, the mute mode can be initiated by setting the mute bit in the system control register through the serial control interface. The TAS5036 is held in mute state as long as the terminal is low or I²C mute setting is active. This command uses quiet entry and exit sequences to and from the hard mute state.

If an error recovery (described in the PWM section) occurs after a mute request has been received, the device returns from error recovery with the channel volume set as specified by the mute command.

2.3.3 Auto Mute

Auto mute is an automatic sequence that can be enabled or disabled via the serial control interface. The default for this control is enabled. When enabled, the PWM auto mutes an individual channel when a channel receives from 5 ms to 50 ms of consecutive zeros. This time interval can be selectable using the auto mute delay register. The default interval is 5 ms at 48 kHz. This duration is independent of the sample rate. The auto mute state is exited when two consecutive samples of nonzero data are received.

This mode uses the valid low to provide a low-noise floor while maintaining a short startup time. Noise free entry and exit is achieved by using the PWM quiet start and stop sequences.

2.3.4 Individual Channel Mute

Individual channel mute is invoked through the serial interface. Individual channel mute permits each channel of the TAS5036 to be individually muted and unmuted. The operation that is performed is identical to the mute operation; however, it is performed on a per channel basis. A TAS5036 channel is held in the mute state as long as the serial interface mute setting for that channel is set.

2.3.5 De-Emphasis Filter

For audio sources that have been pre-emphasized, a precision 50- μ s/15- μ s de-emphasis filter is provided to support the sampling rates of 32 kHz, 44.1 kHz, and 48 kHz. See Figure 2–11 for a graph showing the de-emphasis filtering characteristics. De-emphasis is set using two bits in the system control register.

Table 2–10. De-Emphasis Filter Characteristics

DEM_SEL2 (MSB)	DEM_SEL1	DESCRIPTION
0	0	De-emphasis disabled
0	1	De-emphasis enabled for Fs = 48 kHz
1	0	De-emphasis enabled for Fs = 44 kHz
1	1	De-emphasis enabled for Fs = 32 kHz

Following the change of state of the de-emphasis bits, the PWM outputs go into the soft mute state. After 128 LRCLK periods for initialization, the PWM outputs are driven to the normal (unmuted) mode.

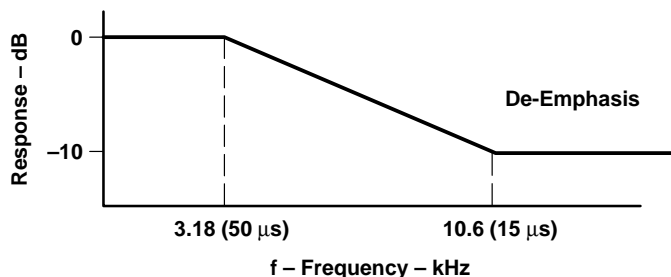

Figure 2–11. De-Emphasis Filter Characteristics

2.4 Pulse Width Modulator (PWM)

The TAS5036 contains six channels of high performance digital Equibit PWM modulators that are designed to drive switching output stages (back ends) in both single-ended (SE) and H-bridge (bridge tied load) configuration. The TAS5036 device uses noise shaping and sophisticated error correction algorithms to achieve high power efficiency and high-performance digital audio reproduction.

The PWM provides six pseudo-differential outputs to drive six monolithic power stages (such as TAS5110) or six discrete differential power stages using gate drivers (such as the TAS5182) and MOSFETs in single-ended or bridged configurations. The TAS5036 also provides a high performance differential output that can be used to drive an external analog headphone amplifier.

2.4.1 Clipping Indicator

The clipping output is designed to indicate clipping. When any of the six PWM outputs exceeds the maximum allowable amplitude, the clipping indicator is asserted. The clipping indicator is cleared every 10 ms.

2.4.2 Error Recovery

Error recovery is used to provide error management and to permit the PWM output to be reset while preserving all inter-volume, inter-channel delay, dc offsets, and the other internal settings. Error recovery is initiated by bringing the /ERR_RCVRY terminal low for a minimum 5 MCLK_IN cycles or by setting the error recovery bit in control register 1. Error recovery is a level sensitive signal.

The device also performs an error recovery automatically:

- When the speed configuration is changed to normal, double, or quad speed
- Following a change in the serial data bus interface configuration

When $\overline{\text{ERR_RCVRY}}$ is brought low, all valid signals go low, and the PWM-P and PWM-M outputs go low. If there are any pending speed configurations, these changes are then performed. When $\overline{\text{ERR_RCVRY}}$ is brought high, a delay of 4 ms to 5 ms is performed before the system starts the output re-initialization sequence. After the initialization time, the TAS5036 begins normal operation. During error recovery, all controls and device settings that were not updated are maintained in their current configurations.

To permit error recovery to be used to provide TAS5100 error management and recovery, the delay between the start of (falling edge) error recovery and the falling edge of valid 1 through valid 6 is selectable. This delay can be selected to be either 6 μs or 47 μs.

During error recovery all serial data bus operations are ignored. At the conclusion of the sequence, the error recovery register bit is returned to normal operation state. Table 2–11 shows the device output signal states while during error recovery.

Table 2–11. Device Outputs During Error Recovery

SIGNAL	MODE	SIGNAL STATE
Valid 1–Valid 6	All	Low
PWM P-outputs	All	Low
PWM M-outputs	All	Low
MCLKOUT	All	Low
SCLK	Master	Low
SCLK	Slave	Signal input
LRCLK	Master	Low
LRCLK	Slave	Signal input
SDA	All	Signal input
CLIP	All	High

The transitions are done using a quiet entrance and exit sequence to prevent pops and clicks.

2.4.3 Individual Channel Error Recovery

Individual channel error recovery is used to provide error management and to permit the PWM output to be turned off. Error recovery is initiated by setting one or more of the six error recovery bits in the error recovery register to low.

While the error recover bits are brought low, the valid signals goes to the low state. When the error recovery bits are brought high, a delay of 4 ms to 5 ms occurs before the channels are returned to normal operation.

The delay between the falling edge of the error recover bit and the falling edge of valid 1 though valid 6 is selectable. This delay can be selected to be either 6 μ s or 47 μ s.

The TAS5036 controls the relative timing of the pseudo-differential drive control signals plus the valid signal to minimize the production of system noise during error recovery operations. The transitions to valid low and valid high are done using an almost quiet entrance and exit sequence to prevent pops and clicks.

2.4.4 PWM DC-Offset Correction

An 8-bit value can be programmed to each of the six PWM offset correction registers to correct for any offset present in the output stages. The offset correction is divided into 256 intervals with a total offset correction of $\pm 1.56\%$ of full scale. The default value is zero correction represented by 00 (hex). These values can be changed at any time through the serial control interface.

2.4.5 Inter-Channel Delay

An 8-bit value can be programmed to each of the six PWM inter-channel delay registers to add a delay per channel from 0 to 255 clock cycles. The delays correspond to cycles of the high-speed internal clock, DCLK (or alternatively the external PLL clock frequency). Each subsequent channel has a default value that is N DCLKs larger than the preceding channel. The default values are 0 for the first channel and 16 for each successive channel.

These values can be updated upon power up through the serial control interface. This delay is generated in the PWM block with the appropriate control signals generated in the CTL block.

These values can be changed at any time through the serial control interface. The optimum performance of the TAS5036 can be achieved using an interchannel delay of 21.

2.4.6 ABD Delay

A 5-bit value is used to delay the A PWM signals with respect to B PWM signals. The value is the same for all channels. It can be programmed from 0 to 31 DCLK clock cycles. The default values is 11 DCLK clock cycles (01011). This value is mask programmable. These values can be changed at any time through the serial control interface.

The optimum performance of the TAS5036 can be achieved with an ABD delay of 30.

2.4.7 PWM/H-Bridge and Discrete H-Bridge Driver Interface

The TAS5036 provides six PWM outputs, which are designed to drive switching output stages (back-ends) in both single-ended (SE) and H-bridge (bridge tied load) configuration. The back-ends may be monolithic power stages (such as the TAS5110) or six discrete differential power stages using gate drivers (such as the TAS55182) and MOSFETs in single-ended or bridged configurations.

The TAS5110 device is optimised for bridge tied load (BTL) configurations. These devices require a pure differential PWM signal with a third signal (VALID) to control the MUTE state. In the MUTE state, the TAS5110 OUTA and OUTB are both low.

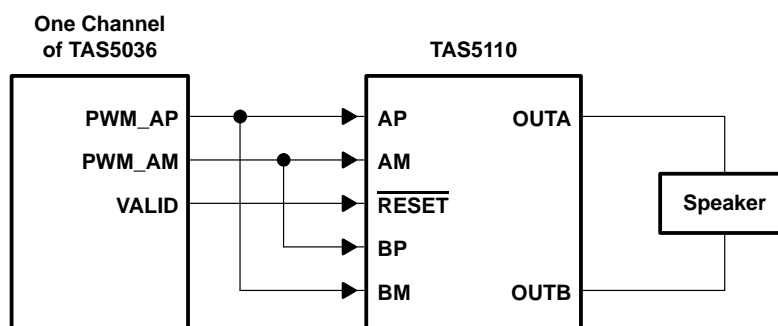

Figure 2–12. PWM Outputs and H-Bridge Driven in BTL Configuration

2.5 I²C Serial Control Interface

The TAS5036 has a bidirectional serial control interface that is compatible with the I²C (Inter IC) bus protocol and supports both 100 KBPS and 400 KBPS data transfer rates for single and multiple byte write and read operations. This is a slave only device that does not support a multi-master bus environment or wait state insertion. The control interface is used to program the registers of the device and to read device status.

The TAS5036 supports the standard-mode I²C bus operation (100 kHz maximum) and the fast I²C bus operation (400 kHz maximum). The TAS5036 performs all I²C operations without I²C wait cycles.

The I²C bus employs two signals; SDA (data) and SCL (clock), to communicate between integrated circuits in a system. Data is transferred on the bus serially one bit at a time. The address and data are transferred in byte (8 bit) format with the most significant bit (MSB) transferred first. In addition, each byte transferred on the bus is acknowledged by the receiving device with an acknowledge bit. Each transfer operation begins with the master device driving a start condition on the bus and ends with the master device driving a stop condition on the bus. The bus uses transitions on the data terminal (SDA) while the clock is high to indicate a start and stop conditions. A high-to-low transition on SDA indicates a start, and a low-to-high transition indicates a stop. Normal data bit transitions must occur within the low time of the clock period. These conditions are shown in Figure 2–13. The master generates the 7-bit slave address and the read/write (R/W) bit to open communication with another device and then waits for an acknowledge condition. The TAS5036 holds SDA low during acknowledge clock period to indicate an acknowledgement. When this occurs, the master transmits the next byte of the sequence. Each device is addressed by a unique 7-bit slave address plus R/W bit (1 byte). All compatible devices share the same signals via a bidirectional bus using a wired-AND connection. I²C An external pullup resistor must be used for the SDA and SCL signals to set the high level for the bus.

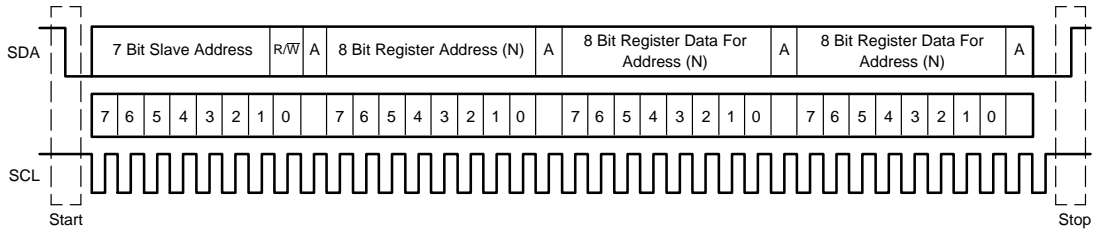

Figure 2–13. Typical I²C Sequence

There are no limits on the number of bytes that can be transmitted between start and stop conditions. When the last word transfers, the master generates a stop condition to release the bus. A generic data transfer sequence is also shown in Figure 2–13.

The 7-bit address for the TAS5036 is 001101X, where X is a programmable address bit. Using the CS0 terminal on the device, the LSB address bit is programmable to permit two devices to be used in a system. These two addresses are licensed I²C addresses and do not conflict with other licensed I²C audio devices. To communicate with the TAS5036, the I²C master uses 0011010 if CS0=0 and 0011011 if CS0=1. In addition to the 7-bit device address, an 8-bit register address is used to direct communication to the proper register location within the device interface.

Read and write operations to the TAS5036 can be done using single byte or multiple byte data transfers.

2.5.1 Single Byte Write

As shown in Figure 2–14, a single byte data write transfer begins with the master device transmitting a start condition followed by the I²C device address and the read/write bit. The read/write bit determines the direction of the data transfer. For a write data transfer, the read/write bit is 0. After receiving the correct I²C device address and the read/write bit, the TAS5036 device responds with an acknowledge bit. Next, the master transmits the address byte or bytes corresponding to the TAS5036 internal memory address being accessed. After receiving the address byte, the TAS5036 again responds with an acknowledge bit. Next, the master device transmits the data byte to be written to the memory address being accessed. After receiving the data byte, the TAS5036 again responds with an acknowledge bit. Finally, the master device transmits a stop condition to complete the single byte data write transfer.

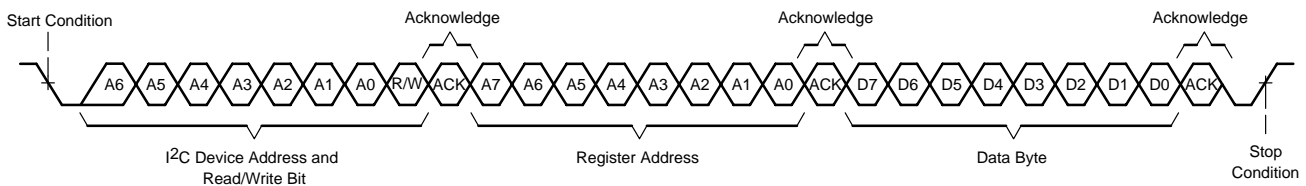

Figure 2–14. Single Byte Write Transfer

2.5.2 Multiple Byte Write

A multiple byte data write transfer is identical to a single byte data write transfer except that multiple data bytes are transmitted by the master device to TAS5036 as shown in Figure 2–15. After receiving each data byte, the TAS5036 responds with an acknowledge bit.

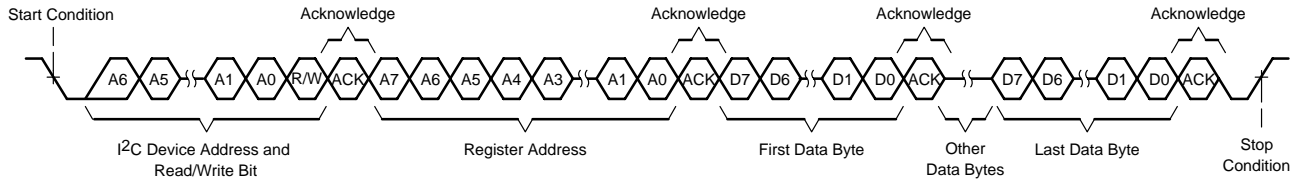

Figure 2-15. Multiple Byte Write Transfer

2.5.3 Single Byte Read

As shown in Figure 2-16, a single byte data read transfer begins with the master device transmitting a start condition followed by the I²C device address and the read/write bit. For the data read transfer, a write followed by a read are actually done. Initially, a write is done to transfer the address byte or bytes of the internal memory address to be read. As a result, the read/write bit is 0. After receiving the TAS5036 address and the read/write bit, the TAS5036 responds with an acknowledge bit. Also, after sending the internal memory address byte or bytes, the master device transmits another start condition followed by the TAS5036 address and the read/write bit again. This time the read/write bit is a 1 indicating a read transfer. After receiving the TAS5036 and the read/write bit, the TAS5036 again responds with an acknowledge bit. Next, the TAS5036 transmits the data byte from the memory address being read. After receiving the data byte, the master device transmits a not acknowledge followed by a stop condition to complete the single byte data read transfer.

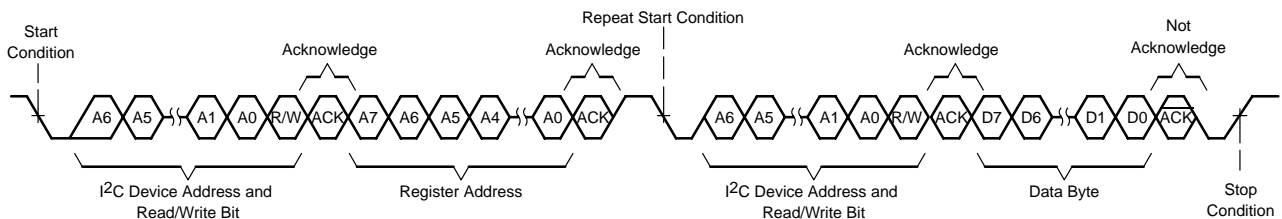

Figure 2-16. Single Byte Read

2.5.4 Multiple Byte Read

A multiple byte data read transfer is identical to a single byte data read transfer except that multiple data bytes are transmitted by the TAS5036 to the master device as shown in Figure 2-17. Except for the last data byte, the master device responds with an acknowledge bit after receiving each data byte.

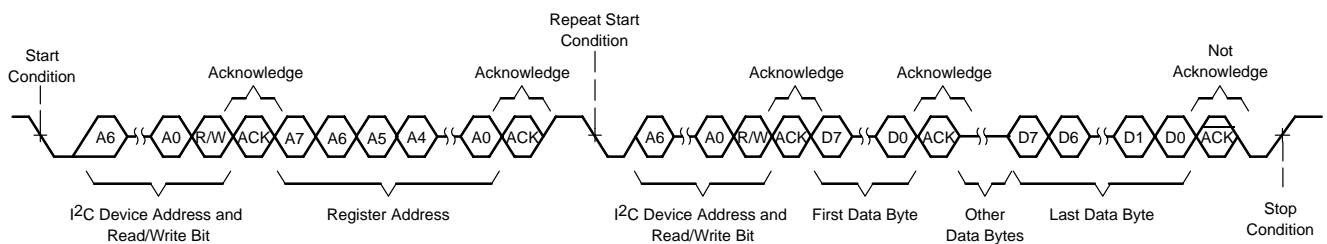

Figure 2-17. Multiple Byte Read

3 Serial Control Interface Register Definitions

Table 3–1 shows the register map for the TAS5036. Default values in this section are in bold.

Table 3–1. I²C Register Map

ADDR HEX	DESCRIPTION
00	General status register
01	Error status register
02	System control register 0
03	System control register 1
04	Error recovery register
05	Automute delay
06	DC-offset control register channel 1
07	DC-offset control register channel 2
08	DC-offset control register channel 3
09	DC-offset control register channel 4
0A	DC-offset control register channel 5
0B	DC-offset control register channel 6
0C	Interchannel delay register channel 1
0D	Interchannel delay register channel 2
0E	Interchannel delay register channel 3
0F	Interchannel delay register channel 4
10	Interchannel delay register channel 5
11	Interchannel delay register channel 6
12	ABD delay register
13	Volume control register channel 1
14	Volume control register channel 2
15	Volume control register channel 3
16	Volume control register channel 4
17	Volume control register channel 5
18	Volume control register channel 6
19	Individual channel mute

The volume table is contained in Appendix A.

Default values are shown in bold in the following tables

NOTE:

The performance of a TDAA system is optimized by setting the PWM timing based upon the type of back-end device that is used and, to a lesser extent, the layout. These values are set during initialization using the I²C serial interface. The specific timing parameter values for each PWM and back-end configuration is contained in the EVM User Manual, Reference Design User Manual, and design application note for these devices. Please refer to the appropriate EVM User Manual, Reference Design user manual, or design application note for these values.

3.1 General Status Register (x00)

Table 3–2. General Status Register (Read Only)

D7	D6	D5	D4	D3	D2	D1	D0	FUNCTION
0	-	-	-	-	-	-	-	No volume update is in progress.
1	-	-	-	-	-	-	-	Volume update is in progress.
-	0	-	-	-	-	-	-	Always 0
-	-	1	0	0	1	1	-	Device identification code
-	-	-	-	-	-	-	0	Any valid signal is inactive (see status register (X03)) (see Note 1).
-	-	-	-	-	-	-	1	No internal errors (all valid signals are high)

NOTE 1: This bit is reset automatically when all of the valid signals are active.

3.2 Error Status Register (x01)

Table 3–3. Error Status Register

D7	D6	D5	D4	D3	D2	D1	D0	FUNCTION
1	-	-	-	-	-	-	-	FS error has occurred
-	1	-	-	-	-	-	-	Control pin change has occurred
-	-	-	1	-	-	-	-	LRCLK error
-	-	-	-	1	-	-	-	MCLK_IN count error
-	-	-	-	-	1	-	-	DCLK phase error with respect to MCLK_IN
-	-	-	-	-	-	1	-	MCLK_IN phase error with respect to DCLK
-	-	-	-	-	-	-	1	PWM timing error
0	0	0	0	0	0	0	0	No errors—no control pins changed

NOTE 1: Write 00 hex to clear error indications in Error Status Register.

3.3 System Control Register 0 (x02)

Table 3–4. System Control Register 0

D7	D6	D5	D4	D3	D2	D1	D0	FUNCTION
0	0	-	-	-	-	-	-	Normal mode (in slave mode—quad speed detected if MCLK_IN = 128 Fs)
0	1	-	-	-	-	-	-	Double speed
1	0	-	-	-	-	-	-	Quad speed
1	1	-	-	-	-	-	-	Illegal
-	-	0	-	-	-	-	-	Use de-emphasis pin controls
-	-	1	-	-	-	-	-	Use de-emphasis I2C controls
-	-	-	0	0	-	-	-	No de-emphasis
-	-	-	0	1	-	-	-	De-emphasis for Fs = 32 kHz
-	-	-	1	0	-	-	-	De-emphasis for Fs = 44.1 kHz
-	-	-	1	1	-	-	-	De-emphasis for Fs = 48 kHz
-	-	-	-	-	0	0	0	16 bit, MSB first; right justified
-	-	-	-	-	0	0	1	20 bit, MSB first; right justified
-	-	-	-	-	0	1	0	24 bit, MSB first; right justified
-	-	-	-	-	0	1	1	16-bit IIS
-	-	-	-	-	1	0	0	20-bit IIS
-	-	-	-	-	1	0	1	24-bit IIS
-	-	-	-	-	1	1	0	16-bit MSB first
-	-	-	-	-	1	1	1	16-bit DSP Frame

3.4 System Control Register 1 (x03)

Table 3–5. System Control Register 1

D7	D6	D5	D4	D3	D2	D1	D0	FUNCTION
0	-	-	-	-	-	-	-	UNUSED
-	-	-	-	-	-	-	-	
-	0	-	-	-	-	-	-	Valid remains high during auto mute.
-	1	-	-	-	-	-	-	Valid goes low during auto mute.
-	-	0	-	-	-	-	-	Valid remains high during mute.
-	-	1	-	-	-	-	-	Valid goes low during mute.
-	-	-	0	-	-	-	-	Mute
-	-	-	1	-	-	-	-	Normal mode
-	-	-	-	0	-	-	-	Set error recovery delay at 6 μ s
-	-	-	-	1	-	-	-	Set error recovery delay at 47 μ s
-	-	-	-	-	0	-	-	Error recovery (forces error recovery initialization sequence)
-	-	-	-	-	1	-	-	Normal mode
-	-	-	-	-	-	0	-	Auto mute disabled
-	-	-	-	-	-	1	-	Auto mute enabled
-	-	-	-	-	-	-	0	Normal mode
-	-	-	-	-	-	-	1	Resets all I ² C registers to their default conditions

3.5 Error Recovery Register (x04)

Table 3–6. Error Recovery Register

D7	D6	D5	D4	D3	D2	D1	D0	FUNCTION
1	1	-	-	-	-	-	-	Unused
-	-	-	-	-	-	-	-	
-	-	0	-	-	-	-	-	Put channel 6 into error recovery mode
-	-	-	0	-	-	-	-	Put channel 5 into error recovery mode
-	-	-	-	0	-	-	-	Put channel 4 into error recovery mode
-	-	-	-	-	0	-	-	Put channel 3 into error recovery mode
-	-	-	-	-	-	0	-	Put channel 2 into error recovery mode
-	-	-	-	-	-	-	0	Put channel 1 into error recovery mode
-	-	1	1	1	1	1	1	Normal operation

3.6 Automute Delay Register (x05)

Table 3–7. Automute Delay Register

D7	D6	D5	D4	D3	D2	D1	D0	FUNCTION
0	0	0	0	-	-	-	-	Unused
-	-	-	-	-	-	-	-	
-	-	-	-	0	0	0	0	Set automute delay at 5 ms
-	-	-	-	0	0	0	1	Set automute delay at 10 ms
-	-	-	-	0	0	1	0	Set automute delay at 15 ms
-	-	-	-	0	0	1	1	Set automute delay at 20 ms
-	-	-	-	0	1	0	0	Set automute delay at 25 ms
-	-	-	-	0	1	0	1	Set automute delay at 30 ms
-	-	-	-	0	1	1	0	Set automute delay at 35 ms
-	-	-	-	0	1	1	1	Set automute delay at 40 ms
-	-	-	-	1	-	-	0	Set automute delay at 45 ms
-	-	-	-	1	-	-	1	Set automute delay at 50 ms

3.7 DC-Offset Control Registers (x06–x0B)

Channels 1, 2, 3, 4, 5, and 6 are mapped into (x06, x07, x08, x09, x0A, and x0B).

Table 3–8. DC-Offset Control Registers

D7	D6	D5	D4	D3	D2	D1	D0	FUNCTION
1	0	0	0	0	0	0	0	Maximum correction for positive dc offset (–1.56% FS)
0	0	0	0	0	0	0	0	No dc-offset correction
0	1	1	1	1	1	1	1	Maximum correction for negative dc offset (1.56% FS)

3.8 Interchannel Delay Registers (x0C–x11)

Channels 1, 2, 3, 4, 5, and 6 are mapped into (x0C, x0D, x0E, x0F, x10, and x11).

The first channel delay is set at 0. Each subsequent channel has a default value that is 16 DCLKs larger than the preceding channel.

Table 3–9. Six Inter-Channel Delay Registers

D7	D6	D5	D4	D3	D2	D1	D0	FUNCTION
0	0	0	0	0	0	0	0	Minimum absolute delay, 0 DCLK cycles, default for channel 1
0	0	0	1	0	0	0	0	Default for channel 2
0	0	1	0	0	0	0	0	Default for channel 3
0	0	1	1	0	0	0	0	Default for channel 4
0	1	0	0	0	0	0	0	Default for channel 5
0	1	0	1	0	0	0	0	Default for channel 6
1	1	1	1	1	1	1	1	Maximum absolute delay, 255 DCLK cycles

3.9 ABD Delay Register (x12)

Table 3–10. ABD Delay Register

D7	D6	D5	D4	D3	D2	D1	D0	FUNCTION
0	0	0	-	-	-	-	-	Unused
-	-	-	-	-	-	-	-	
-	-	-	0	0	0	0	0	Minimum ABD delay, 0 DLCK cycles
-	-	-	0	1	0	1	1	Default ABD delay, 11 DLCK cycles
-	-	-	1	1	1	1	1	Maximum ABD delay, 31 DLCK cycles

3.10 Individual Channel Mute Register (x19)

Table 3–11. Individual Channel Mute Register

D7	D6	D5	D4	D3	D2	D1	D0	FUNCTION
1	1	-	-	-	-	-	-	Unused
-	-	-	-	-	-	-	-	
-	-	1	1	1	1	1	1	No channels are muted
-	-	-	-	-	-	-	0	Mute channel 1
-	-	-	-	-	-	0	-	Mute channel 2
-	-	-	-	-	0	-	-	Mute channel 3
-	-	-	-	0	-	-	-	Mute channel 4
-	-	-	0	-	-	-	-	Mute channel 5
-	-	0	-	-	-	-	-	Mute channel 6

4 System Initialization

Reset is used during system initialization to hold the TAS5036 inactive while power (VDD), the master clock (MCLK_IN), the device control, and the data signals become stable. The recommended initialization sequence is to hold $\overline{\text{RESET}}$ low for 24 MCLK_IN cycles after VDD has reached 3 V and the other control signals (MUTE, PDN, M_S, ERR_RCVRY,, DBSPD, and CS0) are stable.

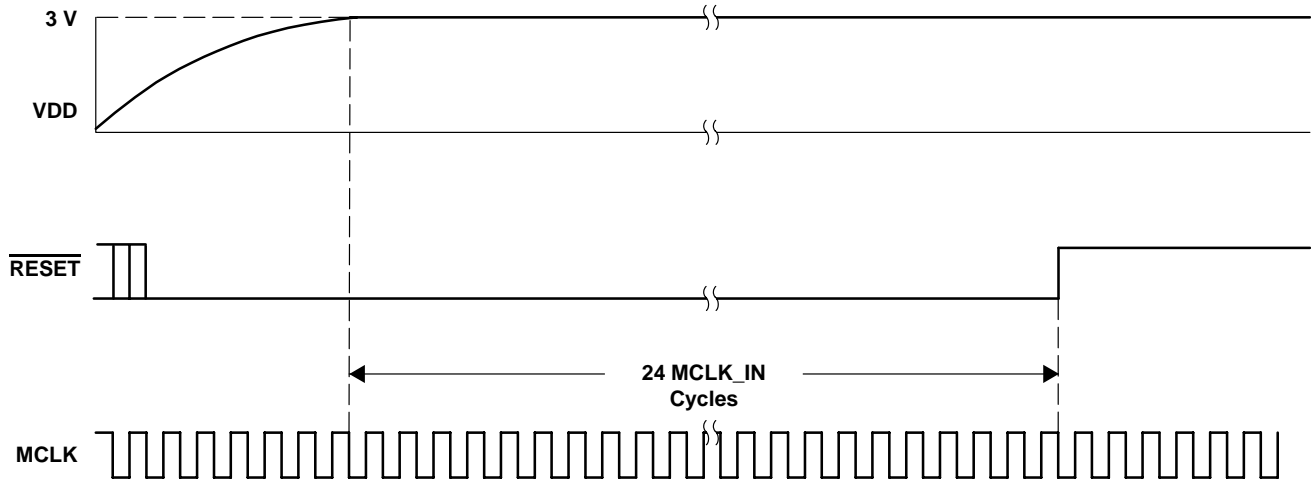

Figure 4–1. $\overline{\text{RESET}}$ During System Initialization

The serial data interface format is then set through the serial data interface control register using the serial control interface.

At this point the TAS5036 is fully operational. However, the operation of the TAS5036 can be tailored as desired to meet specific operating requirements by adjusting the following:

- Automute delay register
- DC-Offset control registers
- Interchannel delay registers

5 Specifications

5.1 Absolute Maximum Ratings Over Operating Temperature Ranges (Unless Otherwise Noted)†

Digital supply voltage range: DVDD_CORE, DVDD_PWM, DVDD_RCL	–0.3 V to 4.2 V
Analog supply voltage range: AVDD_PLL, ADD_OSC	–0.3 V to 4.2 V
Digital input voltage range, V_I	–0.3 V to DVDDX + 0.3 V
Operating free-air temperature	0°C to 85°C
Storage temperature range, T_{stg}	–65°C to 150°C
ESD	2000 V

† Stresses beyond those listed under “absolute maximum ratings” may cause permanent damage to the device. These are stress ratings only, and functional operation of the device at these or any other conditions beyond those indicated under “recommended operating conditions” is not implied. Exposure to absolute-maximum-rated conditions for extended periods may affect device reliability.

5.2 Recommended Operating Conditions ($F_s = 48$ kHz)

			MIN	TYP	MAX	UNIT
Supply voltage	Digital	DVDDX, See Note 1	3	3.3	3.6	V
Supply current	Digital	Operating	60			mA
		Power down, See Note 2	25			μ A
Power dissipation	Digital	Operating	200			mW
		Power down	100			μ W
Supply voltage	Analog	AVDDX, See Note 3	3	3.3	3.6	V
Supply current	Analog	Operating	10			mA
		Power down, See Note 2	25			μ A
Power dissipation	Analog	Operating	35			mW
		Power down, See Note 2	100			μ W

NOTES: 2. DVDD_CORE, DVDD_PWM, DVDD_RCL
 3. If the clocks are turned off.
 4. AVDD_PLL, AVDD_OSC

5.3 Electrical Characteristics Over Recommended Operating Conditions (Unless Otherwise Noted)

5.3.1 Static Digital Specifications Over Recommended Operating Conditions (Unless Otherwise Noted)

PARAMETER		TEST CONDITIONS	MIN	MAX	UNIT
V_{IH}	High-level input voltage		2	DVDD1	V
V_{IL}	Low-level input voltage		0	0.8	V
V_{OH}	High-level output voltage	$I_O = -1$ mA	2.4		V
V_{OL}	Low-level output voltage	$I_O = 4$ mA		0.4	V
I_{Ikg}	Input leakage current		–10	10	μ A

5.3.2 Digital Interpolation Filter and PWM Modulator Over Recommended Operating Conditions (Unless Otherwise Noted) $F_s = 48$ kHz

PARAMETER	TEST CONDITIONS	MIN	TYP	MAX	UNIT
Pass band		0		20	kHz
Pass band ripple			± 0.012		dB
Stop band			24.1		kHz
Stop band attenuation	24.1 kHz to 152.3 kHz	50			dB
Group delay			700		μ s
PWM modulation index (gain)			0.93		

**5.3.3 TAS5036/TAS5100 System Performance Measured at the Speaker Terminals Over Recommended Operating Conditions (Unless Otherwise Noted)
Fs = 48 kHz; Input = 1 Vrms Sine Wave at 1 kHz**

PARAMETER	TEST CONDITIONS	MIN	TYP	MAX	UNIT
SNR (EIAJ)	A-weighted		93		dB
Dynamic range	A-weighted, -60 dB, f = 1 kHz, 20 Hz–20 kHz		95		dB
Signal to (noise + distortion) ratio	0 dB, 1 kHz, 20 Hz–20 kHz		0.08%		
Pad driver power supply rejection ratio	1 kHz				dB
Idle tone rejection					dB
Intermodulation distortion					dB
Frequency response					dB
Crosstalk					dB
Jitter tolerance					ps
PWM modulation index			0.93		

5.4 Switching Characteristics

5.4.1 Command Sequence Timing

5.4.1.1 Reset Timing— $\overline{\text{RESET}}$

CONTROL SIGNAL PARAMETERS OVER RECOMMENDED OPERATING CONDITIONS (UNLESS OTHERWISE NOTED)					
PARAMETER	TEST CONDITIONS	MIN	TYP	MAX	UNIT
$t_w(\overline{\text{RESET}})$	Pulses duration, $\overline{\text{RESET}}$ active	50			ns
$t_p(\text{VALID_LOW})$	Propagation delay			1	μs
$t_p(\text{VALID_HIGH})$	Propagation delay	4		5	ms
$t_d(\text{VOLUME})$	Delay time		42		ms

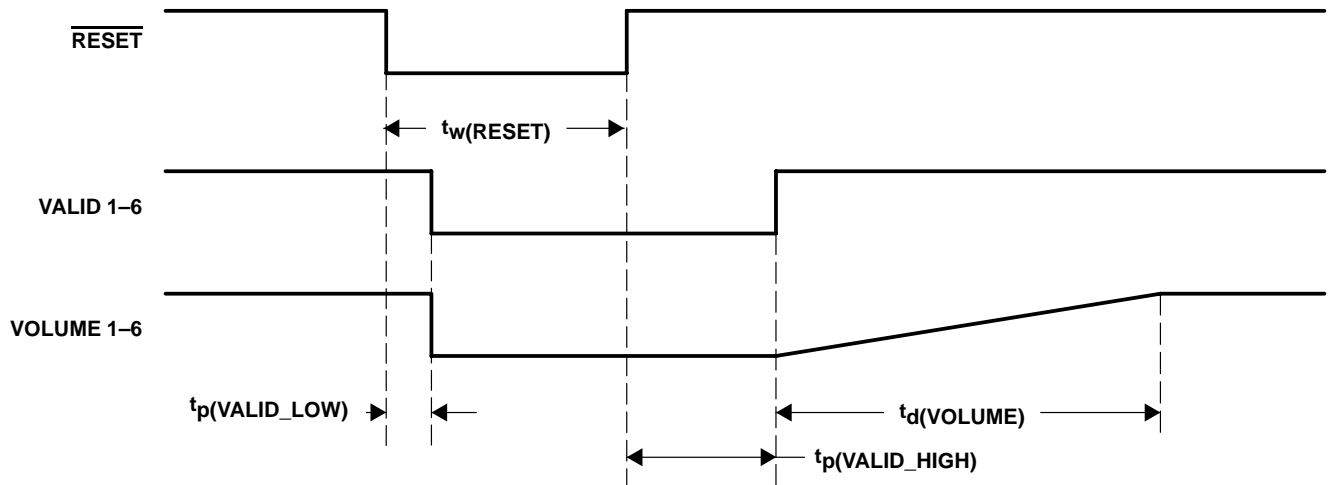

Figure 5–1. $\overline{\text{RESET}}$ Timing

5.4.1.2 Power-Down Timing— $\overline{\text{PDN}}$

5.4.1.2.1 Long Recovery

CONTROL SIGNAL PARAMETERS OVER RECOMMENDED OPERATING CONDITIONS (UNLESS OTHERWISE NOTED)						
PARAMETER		TEST CONDITIONS	MIN	TYP	MAX	UNIT
$t_w(\text{PDN})$	Pulse duration, PDN active		50			ns
$t_d(\text{R PDNR})$	Reset high to PDN rising edge		16 MCLKS			ns
$t_p(\text{VALID_LOW})$					1	μs
$t_p(\text{VALID_HIGH})$			85		100	ms
$t_d(\text{VOLUME})$				42		ms

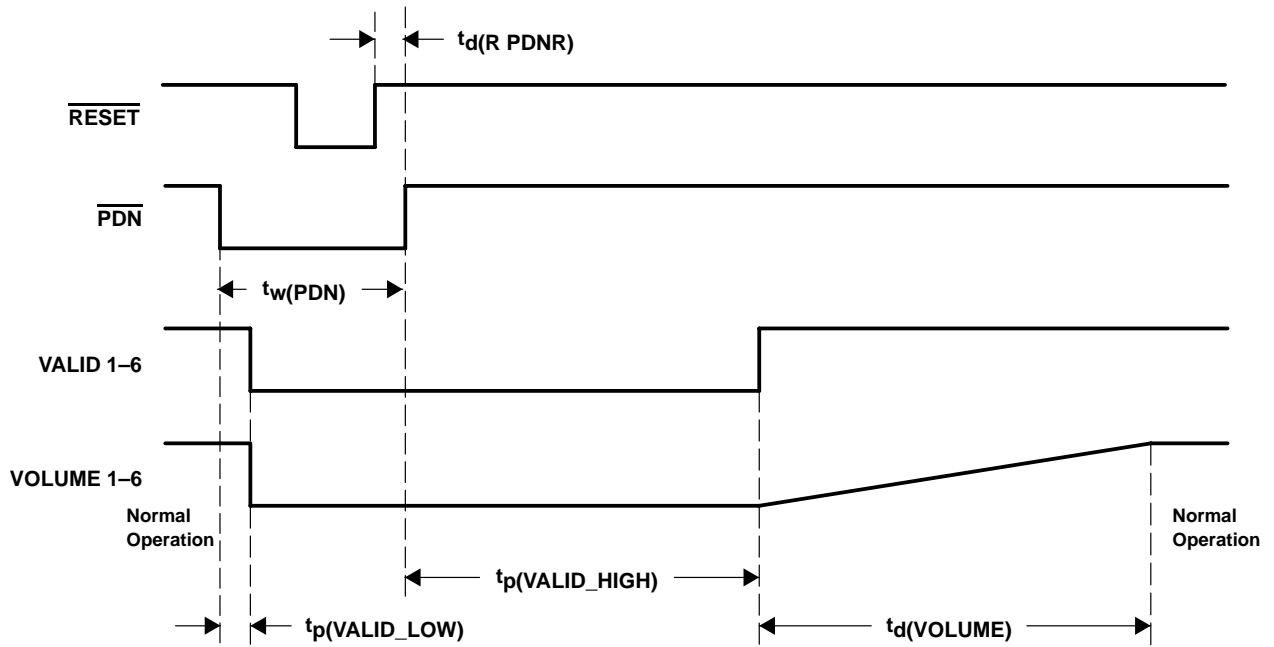

Figure 5-2. Power-Down and Power-Up Timing— $\overline{\text{RESET}}$ Preceding $\overline{\text{PDN}}$

5.4.1.2.2 Short Recovery

CONTROL SIGNAL PARAMETERS OVER RECOMMENDED OPERATING CONDITIONS (UNLESS OTHERWISE NOTED)					
PARAMETER	TEST CONDITIONS	MIN	TYP	MAX	UNIT
$t_w(\text{PDN})$	Pulse duration, PDN active	50			ns
$t_d(\text{R PDNR})$	PDN high to reset rising edge	16 MCLKS			ns
$t_p(\text{VALID_LOW})$				1	μs
$t_p(\text{VALID_HIGH})$		4		5	ms
$t_d(\text{VOLUME})$			42		ms

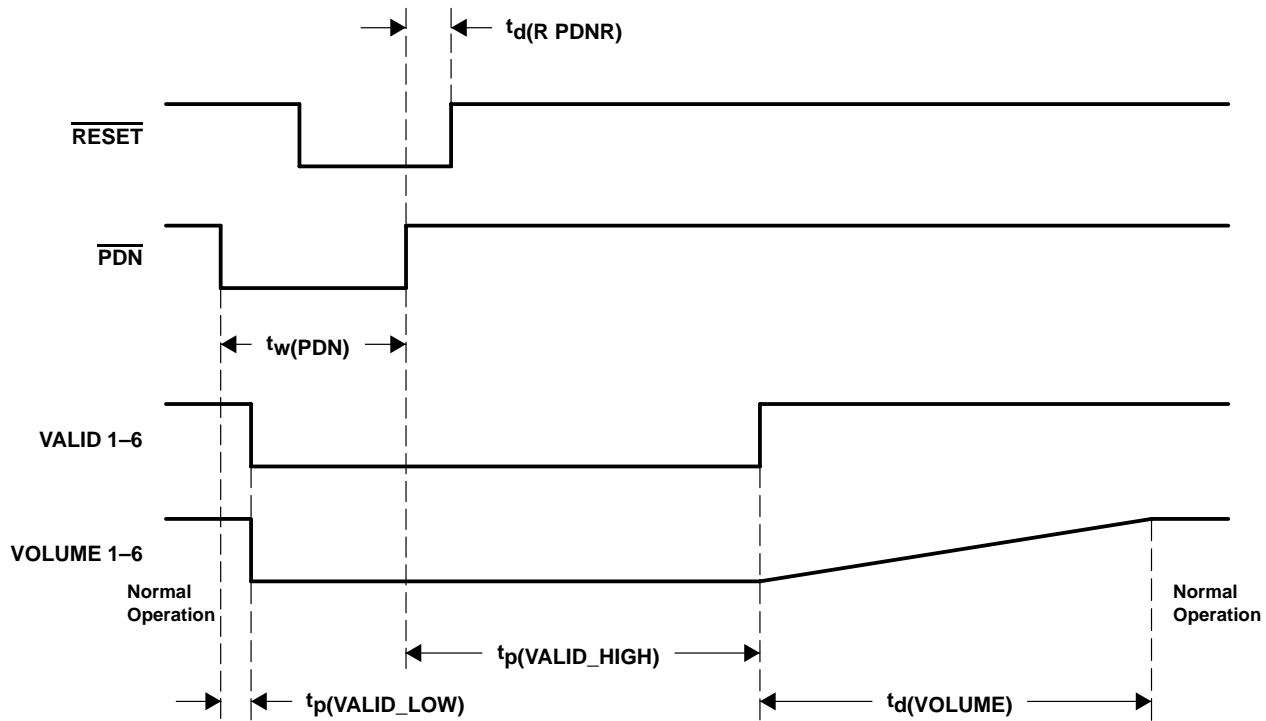

Figure 5–3. Power-Down and Power-Up Timing— $\overline{\text{RESET}}$ Following $\overline{\text{PDN}}$

5.4.1.3 Error Recovery Timing— $\overline{\text{ERR_RCVRY}}$

CONTROL SIGNAL PARAMETERS OVER RECOMMENDED OPERATING CONDITIONS (UNLESS OTHERWISE NOTED)					
PARAMETER	TEST CONDITIONS	MIN	TYP	MAX	UNIT
$t_w(\text{ER})$	Pulse duration, $\overline{\text{ERR_RCVRY}}$ active	5 MCLKS			ns
$t_p(\text{VALID_LOW})$	Selectable for minimum or maximum	6		47	μs
$t_p(\text{VALID_HIGH})$		4		5	ms

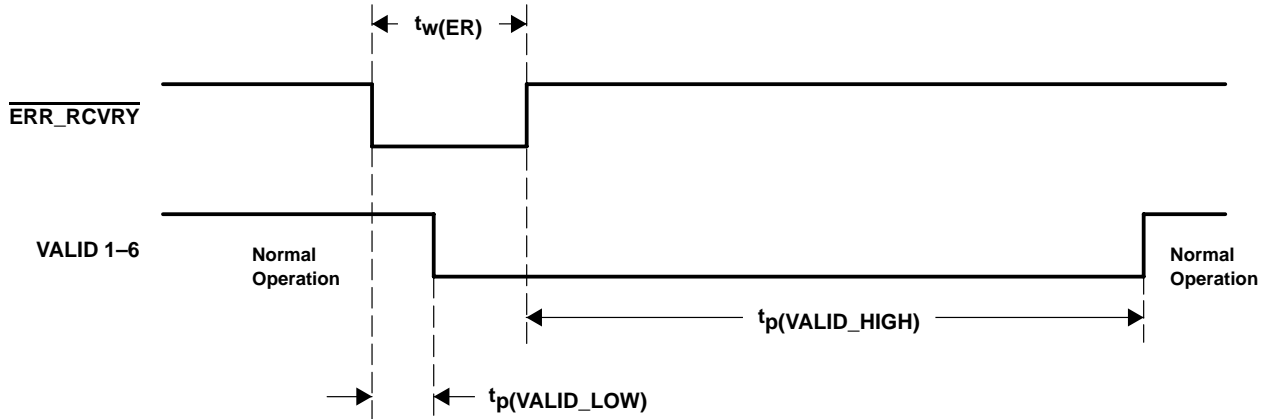

Figure 5–4. Error Recovery Timing

5.4.1.4 MUTE Timing— $\overline{\text{MUTE}}$

CONTROL SIGNAL PARAMETERS OVER RECOMMENDED OPERATING CONDITIONS (UNLESS OTHERWISE NOTED)					
PARAMETER	TEST CONDITIONS	MIN	TYP	MAX	UNIT
$t_w(\text{MUTE})$	Pulse duration, PDN active	3 MCLKS			ns
$t_d(\text{VOL})$			42		ms

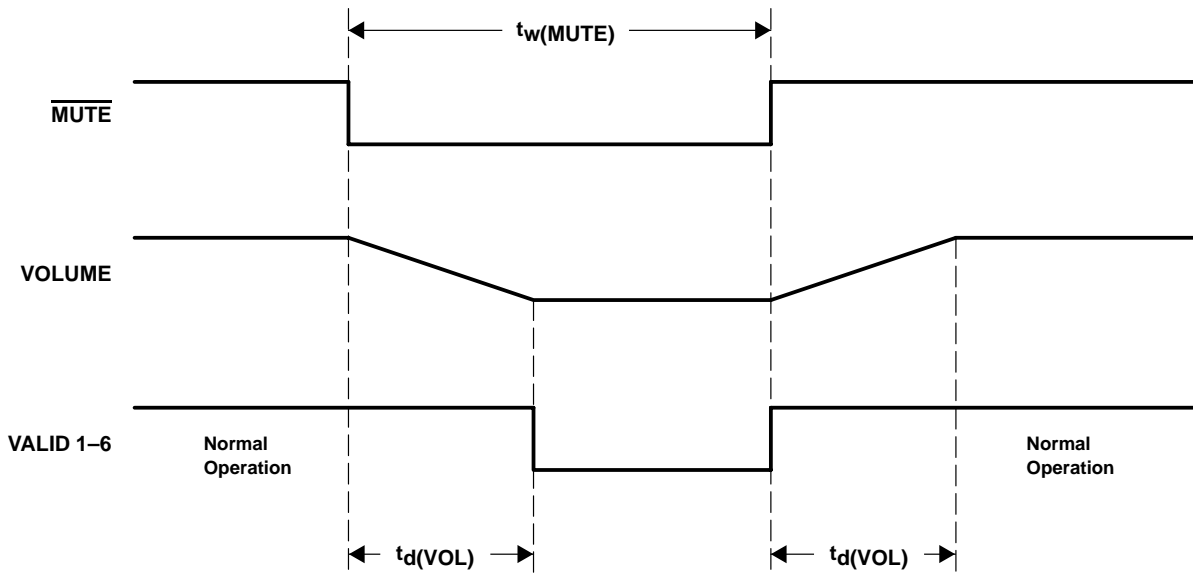

Figure 5–5. Mute Timing

5.4.2 Serial Audio Port

5.4.2.1 Serial Audio Ports Slave Mode Over Recommended Operating Conditions (Unless Otherwise Noted)

PARAMETER		MIN	TYP	MAX	UNIT
f(SCLK)	Frequency, SCLK			12.288	MHz
t _{su} (SDIN)	SDIN setup time before SCLK rising edge	20			ns
t _h (SDIN)	SDIN hold time before SCLK rising edge	10			ns
f(LRCLK)	LRCLK frequency	32	48	192	kHz
	MCLK_IN duty cycle		50%		
	SCLK duty cycle		50%		
	LRCLK duty cycle		50%		
t _{su} (LRCLK)	LRCLK setup time before SCLK rising edge	20			ns
	MCLK High and Low time	20			ns

5.4.2.2 Serial Audio Ports Master Mode, Load Conditions 50 pF Over Recommended Operating Conditions (Unless Otherwise Noted)

PARAMETER		MIN	TYP	MAX	UNIT
t(MSD)	MCLK_IN to SCLK	0		5	ns
t(MLRD)	MCLK_IN to LRCLK	0		5	ns

5.4.2.3 DSP Serial Interface Mode Over Recommended Operating Conditions (Unless Otherwise Noted)

PARAMETER		MIN	TYP	MAX	UNIT
f(SCLK)	SCLK frequency			12.288	MHz
t _d (FS)	Delay time, SCLK rising to Fs				ns
t _w (FSHIGH)	Pulse duration, sync		1/(64xfs)		ns
t _{su} (SDIN)	SDIN and LRCLK setup time before SCLK falling edge	20			ns
t _h (SDIN)	SDIN and LRCLK hold time from SCLK falling edge	10			ns
	SCLK duty cycle		50%		

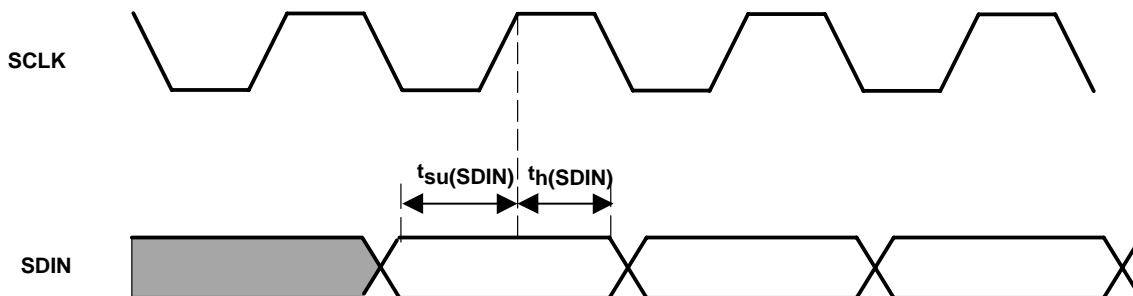
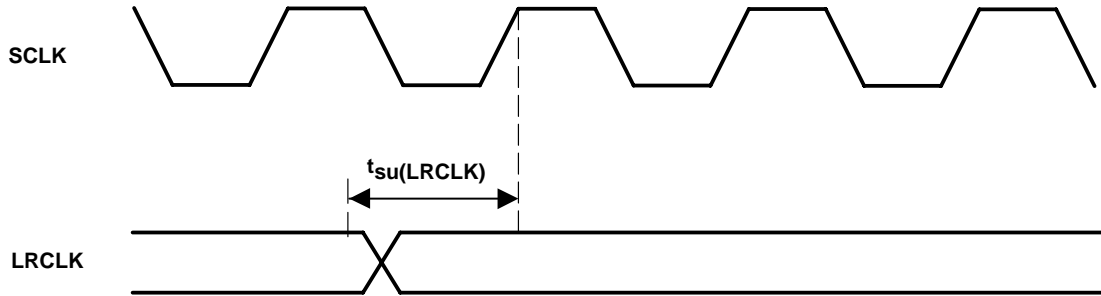

Figure 5–6. Right-Justified, IIS, Left-Justified Serial Protocol Timing



NOTE: Serial data is sampled with the rising edge of SCLK (setup time = 20 ns and hold time = 10 ns).

Figure 5–7. Right, Left, and IIS Serial Mode Timing Requirement

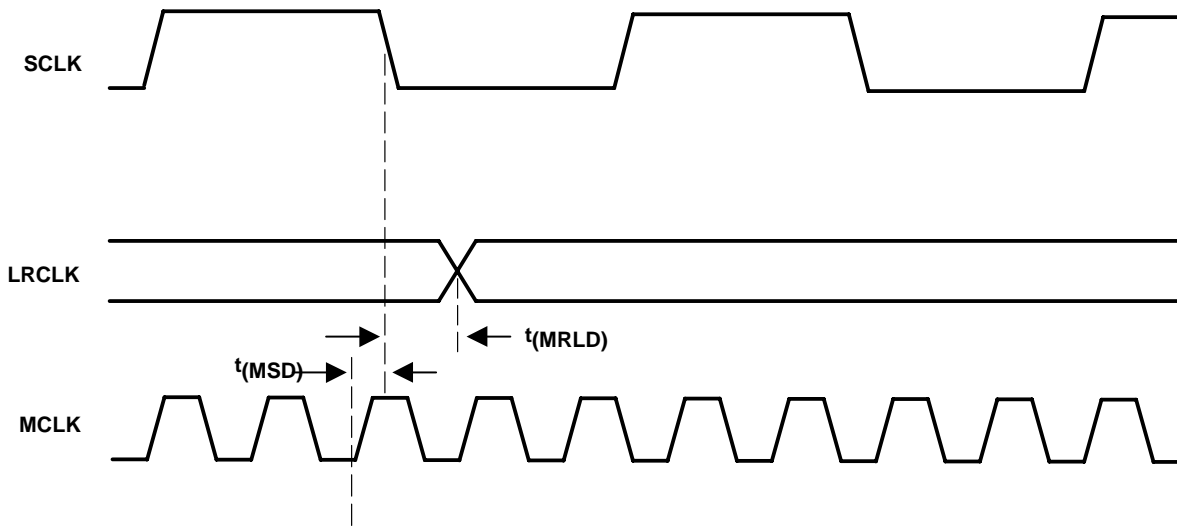

Figure 5–8. Serial Audio Ports Master Mode Timing

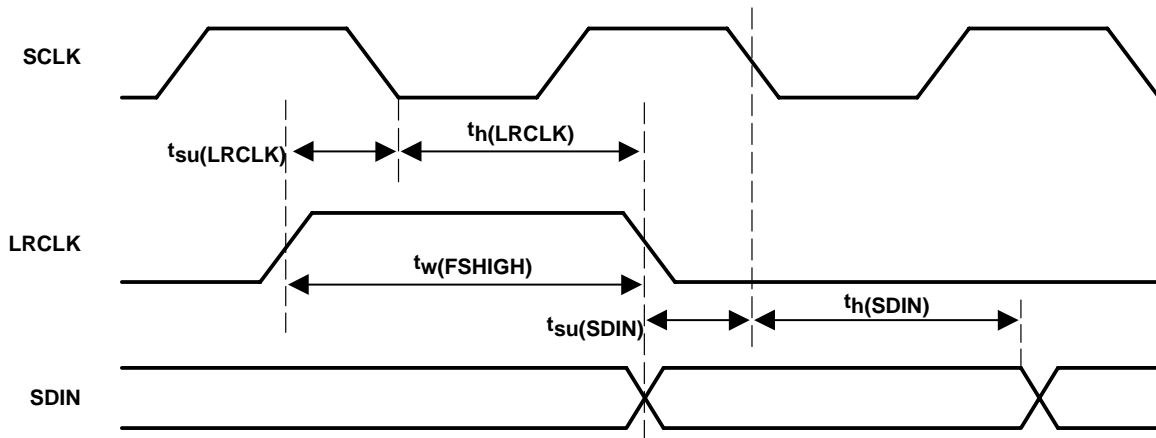

Figure 5–9. DSP Serial Port Timing

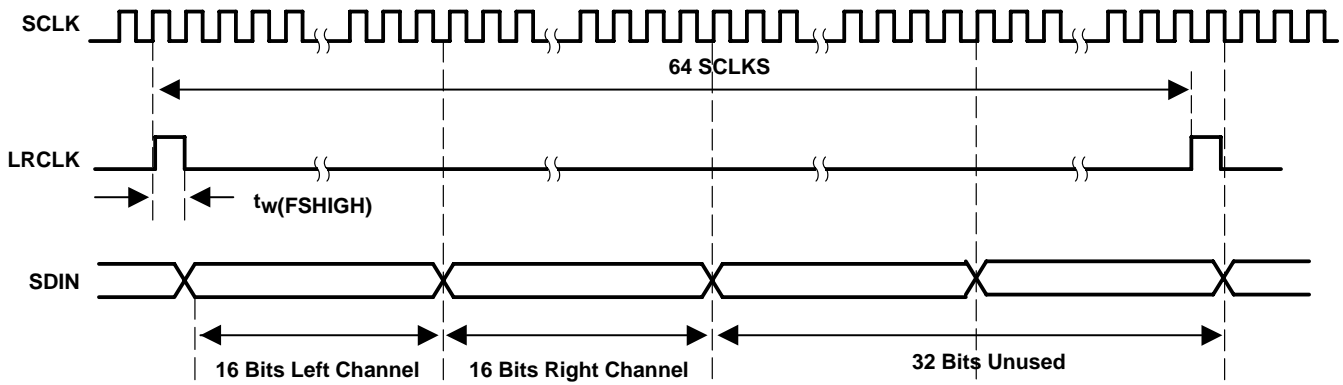

Figure 5–10. DSP Serial Port Expanded Timing

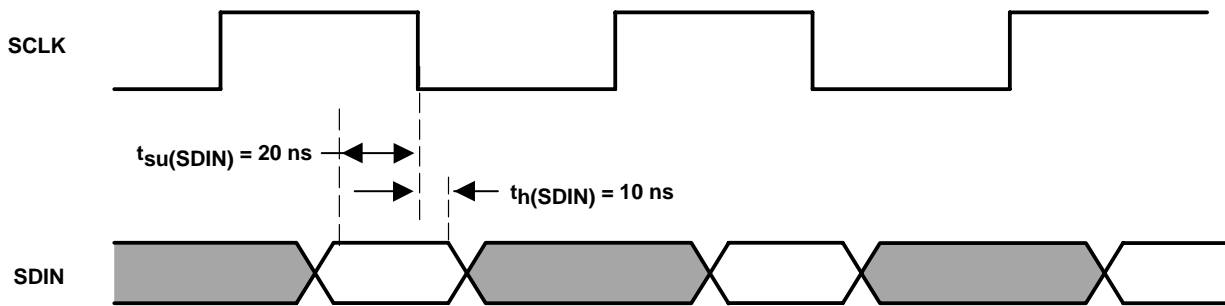

Figure 5–11. DSP Absolute Timing

5.4.3 Serial Control Port—I²C Operation

5.4.3.1 Timing Characteristics for I²C Interface Signals Over Recommended Operating Conditions (Unless Otherwise Noted)

PARAMETER		TEST CONDITIONS	STANDARD MODE		FAST MODE		UNIT
			MIN	MAX	MIN	MAX	
f _{SCL}	Frequency, SCL		0	100	0	400	kHz
t _{w(H)}	Pulse duration, SCL high		4		0.6		μs
t _{w(L)}	Pulse duration, SCL low		4.7		1.3		μs
t _r	Rise time, SCL and SDA			1000		300	ns
t _f	Fall time, SCL and SDA			300		300	ns
t _{su1}	Setup time, SDA to SCL		250		100		ns
t _{h1}	Hold time, SCL to SDA		0		0		ns
t _(buf)	Bus free time between stop and start condition		4.7		1.3		μs
t _{su2}	Setup time, SCL to start condition		4.7		0.6		μs
t _{h2}	Hold time, start condition to SCL		4		0.6		μs
t _{su3}	Setup time, SCL to stop condition		4		0.6		μs
C _L	Load capacitance for each bus line			400		400	pF

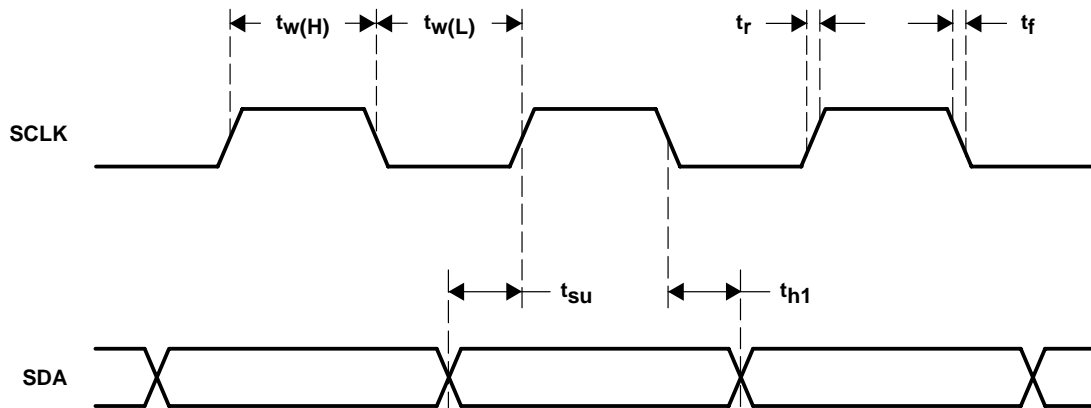

Figure 5–12. SCL and SDA Timing

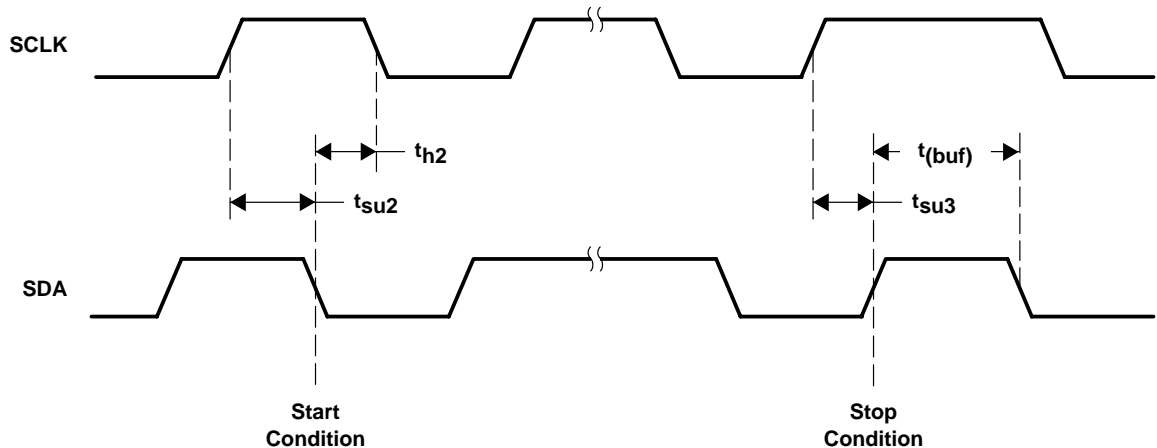

Figure 5–13. Start and Stop Conditions Timing

6 Application Information

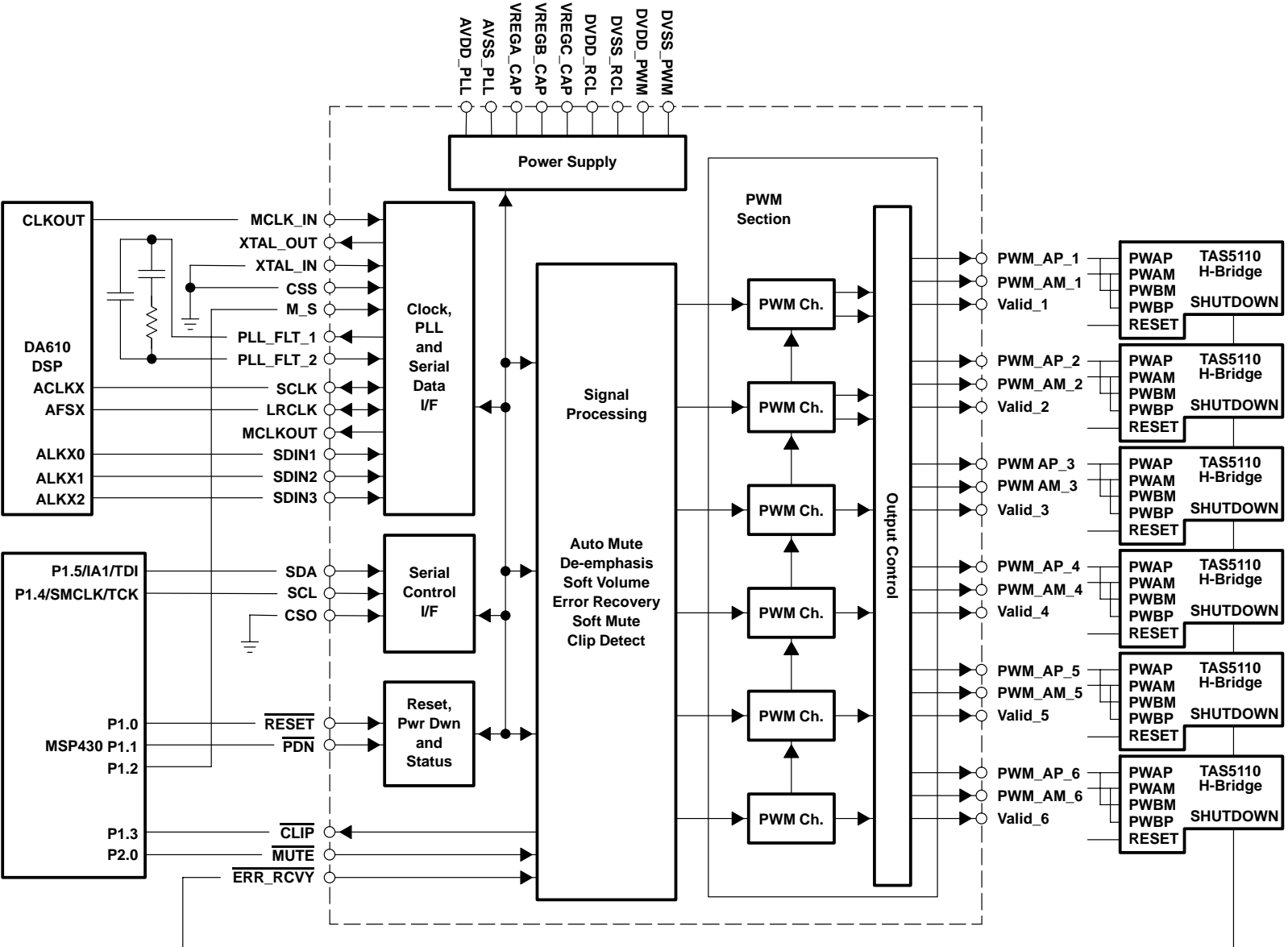

Figure 6-1. Typical TAS5036 Application

6.1 Serial Audio Interface Clock Master and Slave Interface Configuration

6.1.1 Slave Configuration

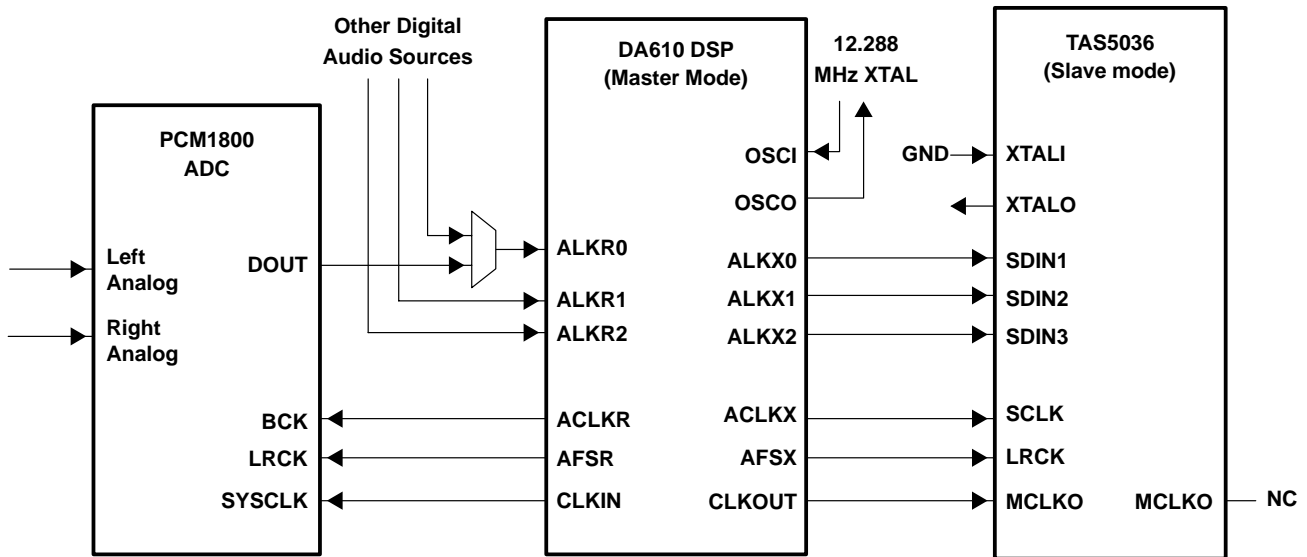

Figure 6-2. TAS5036 Serial Audio Port—Slave Mode Connection Diagram

6.1.2 Master Configuration

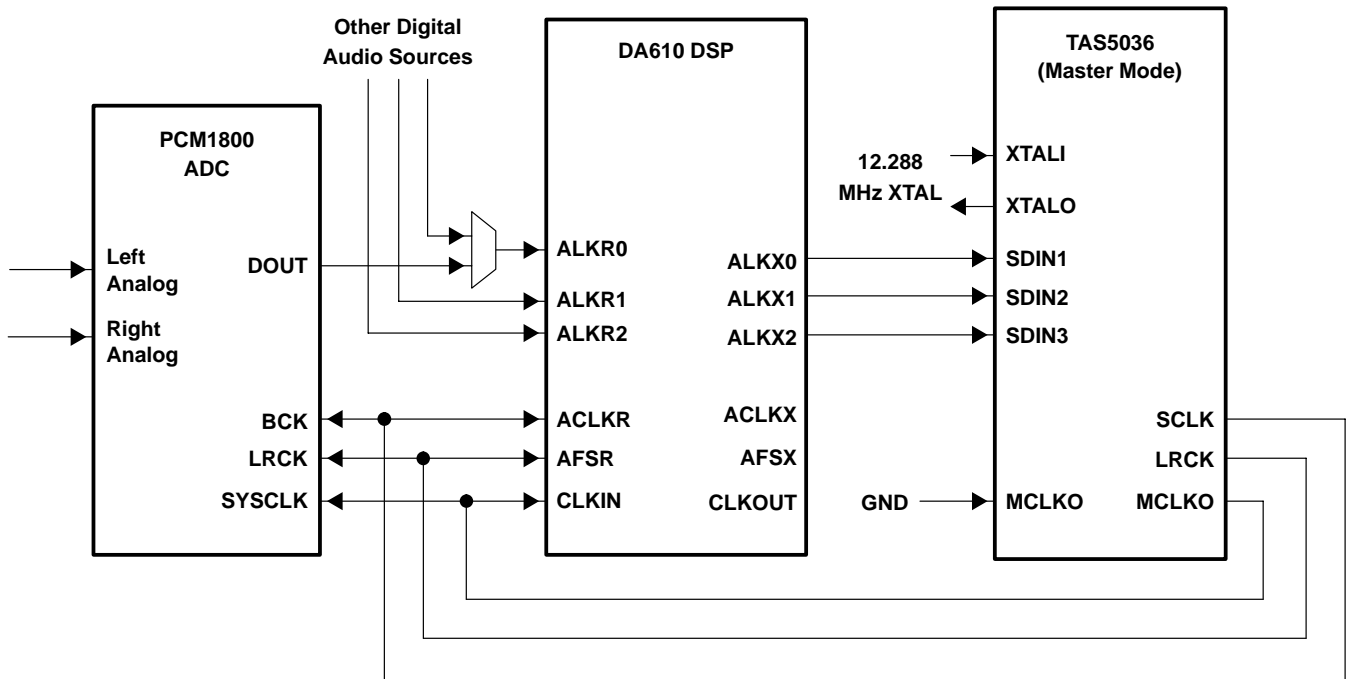

Figure 6-3. TAS5036 Serial Audio Port—Master Mode Connection Diagram

Appendix A—Volume Table

VOLUME SETTING	REGISTER VOLUME (BIN)	GAIN dB
	D7 – D0	
249	11111001	24
248	11111000	23.5
247	11110111	23
246	11110110	22.5
245	11110101	22
244	11110100	21.5
243	11110011	21
242	11110010	20.5
241	11110001	20
240	11110000	19.5
239	11101111	19
238	11101110	18.5
237	11101101	18
236	11101100	17.5
235	11101011	17
234	11101010	16.5
233	11101001	16
232	11101000	15.5
231	11100111	15
230	11100110	14.5
229	11100101	14
228	11100100	13.5
227	11100011	13
226	11100010	12.5
225	11100001	12
224	11100000	11.5
223	11011111	11
222	11011110	10.5
221	11011101	10
220	11011100	9.5
219	11011011	9
218	11011010	8.5
217	11011001	8
216	11011000	7.5
215	11010111	7
214	11010110	6.5
213	11010101	6
212	11010100	5.5
211	11010011	5
210	11010010	4.5
209	11010001	4
208	11010000	3.5
207	11001111	3
206	11001110	2.5

VOLUME SETTING	REGISTER VOLUME (BIN)	GAIN dB
	D7 – D0	
205	11001101	2
204	11001100	1.5
203	11001011	1
202	11001010	0.5
201	11001001	0
200	11001000	-0.5
199	11000111	-1
198	11000110	-1.5
197	11000101	-2
196	11000100	-2.5
195	11000011	-3
194	11000010	-3.5
193	11000001	-4
192	11000000	-4.5
191	10111111	-5
190	10111110	-5.5
189	10111101	-6
188	10111100	-6.5
187	10111011	-7
186	10111010	-7.5
185	10111001	-8
184	10111000	-8.5
183	10110111	-9
182	10110110	-9.5
181	10110101	-10
180	10110100	-10.5
179	10110011	-11
178	10110010	-11.5
177	10110001	-12
176	10110000	-12.5
175	10101111	-13
174	10101110	-13.5
173	10101101	-14
172	10101100	-14.5
171	10101011	-15
170	10101010	-15.5
169	10101001	-16
168	10101000	-16.5
167	10100111	-17
166	10100110	-17.5
165	10100101	-18
164	10100100	-18.5
163	10100011	-19
162	10100010	-19.5

VOLUME SETTING	REGISTER VOLUME (BIN)	GAIN dB
	D7 – D0	
161	10100001	-20
160	10100000	-20.5
159	10011111	-21
158	10011110	-21.5
157	10011101	-22
156	10011100	-22.5
155	10011011	-23
154	10011010	-23.5
153	10011001	-24
152	10011000	-24.5
151	10010111	-25
150	10010110	-25.5
149	10010101	-26
148	10010100	-26.5
147	10010011	-27
146	10010010	-27.5
145	10010001	-28
144	10010000	-28.5
143	10001111	-29
142	10001110	-29.5
141	10001101	-30
140	10001100	-30.5
139	10001011	-31
138	10001010	-31.5
137	10001001	-32
136	10001000	-32.5
135	10000111	-33
134	10000110	-33.5
133	10000101	-34
132	10000100	-34.5
131	10000011	-35
130	10000010	-35.5
129	10000001	-36
128	10000000	-36.5
127	01111111	-37
126	01111110	-37.5
125	01111101	-38
124	01111100	-38.5
123	01111011	-39
122	01111010	-39.5
121	01111001	-40
120	01111000	-40.5
119	01110111	-41
118	01110110	-41.5
117	01110101	-42

VOLUME SETTING	REGISTER VOLUME (BIN)	GAIN dB
	D7 – D0	
116	01110100	-42.5
115	01110011	-43
114	01110010	-43.5
113	01110001	-44
112	01110000	-44.5
111	01101111	-45
110	01101110	-45.5
109	01101101	-46
108	01101100	-46.5
107	01101011	-47
106	01101010	-47.5
105	01101001	-48
104	01101000	-48.5
103	01100111	-49
102	01100110	-49.5
101	01100101	-50
100	01100100	-50.5
99	01100011	-51
98	01100010	-51.5
97	01100001	-52
96	01100000	-52.5
95	01011111	-53
94	01011110	-53.5
93	01011101	-54
92	01011100	-54.5
91	01011011	-55
90	01011010	-55.5
89	01011001	-56
88	01011000	-56.5
87	01010111	-57
86	01010110	-57.5
85	01010101	-58
84	01010100	-58.5
83	01010011	-59
82	01010010	-59.5
81	01010001	-60
80	01010000	-60.5
79	01001111	-61
78	01001110	-61.5
77	01001101	-62
76	01001100	-62.5
75	01001011	-63
74	01001010	-63.5
73	01001001	-64
72	01001000	-64.5

VOLUME SETTING	REGISTER VOLUME (BIN)	GAIN dB
	D7 – D0	
71	01000111	–65
70	01000110	–65.5
69	01000101	–66
68	01000100	–66.5
67	01000011	–67
66	01000010	–67.5
65	01000001	–68
64	01000000	–68.5
63	00111111	–69
62	00111110	–69.5
61	00111101	–70
60	00111100	–70.5
59	00111011	–71
58	00111010	–71.5
57	00111001	–72
56	00111000	–72.5
55	00110111	–73
54	00110110	–73.5
53	00110101	–74
52	00110100	–74.5
51	00110011	–75
50	00110010	–75.5
49	00110001	–76
48	00110000	–76.6
47	00101111	–77
46	00101110	–77.5
45	00101101	–78
44	00101100	–78.5
43	00101011	–79
42	00101010	–79.6
41	00101001	–80.1
40	00101000	–80.6
39	00100111	–81.1
38	00100110	–81.5
37	00100101	–82.1

VOLUME SETTING	REGISTER VOLUME (BIN)	GAIN dB
	D7 – D0	
36	00100100	–82.6
35	00100011	–83
34	00100010	–83.5
33	00100001	–84
32	00100000	–84.6
31	00011111	–85.1
30	00011110	–85.8
29	00011101	–86.1
28	00011100	–86.8
27	00011011	–87.2
26	00011010	–87.5
25	00011001	–88.4
24	00011000	–88.8
23	00010111	–89.3
22	00010110	–89.8
21	00010101	–90.3
20	00010100	–90.9
19	00010011	–91.5
18	00010010	–92.1
17	00010001	–92.8
16	00010000	–93.6
15	00001111	–94.4
14	00001110	–95.3
13	00001101	–96.3
12	00001100	–97.5
11	00001011	–98.8
10	00001010	–100.4
9	00001001	–102.4
8	00001000	–104.9
7	00000111	–108.4
6	00000110	–114.4
5	00000101	MUTE
4	00000100	MUTE
3	00000011	MUTE
2	00000010	MUTE
1	00000001	MUTE
0	00000000	MUTE

PACKAGING INFORMATION

Orderable Device	Status ⁽¹⁾	Package Type	Package Drawing	Pins	Package Qty	Eco Plan ⁽²⁾	Lead/Ball Finish	MSL Peak Temp ⁽³⁾
TAS5036IPFC	NRND	TQFP	PFC	80	119	Green (RoHS & no Sb/Br)	CU NIPDAU	Level-4-260C-72 HR
TAS5036IPFCR	NRND	TQFP	PFC	80	1000	Green (RoHS & no Sb/Br)	CU NIPDAU	Level-4-260C-72 HR
TAS5036PFC	OBSOLETE	TQFP	PFC	80		TBD	Call TI	Call TI
TAS5036PFCR	OBSOLETE	TQFP	PFC	80		TBD	Call TI	Call TI

⁽¹⁾ The marketing status values are defined as follows:

ACTIVE: Product device recommended for new designs.

LIFEBUY: TI has announced that the device will be discontinued, and a lifetime-buy period is in effect.

NRND: Not recommended for new designs. Device is in production to support existing customers, but TI does not recommend using this part in a new design.

PREVIEW: Device has been announced but is not in production. Samples may or may not be available.

OBSOLETE: TI has discontinued the production of the device.

⁽²⁾ Eco Plan - The planned eco-friendly classification: Pb-Free (RoHS), Pb-Free (RoHS Exempt), or Green (RoHS & no Sb/Br) - please check <http://www.ti.com/productcontent> for the latest availability information and additional product content details.

TBD: The Pb-Free/Green conversion plan has not been defined.

Pb-Free (RoHS): TI's terms "Lead-Free" or "Pb-Free" mean semiconductor products that are compatible with the current RoHS requirements for all 6 substances, including the requirement that lead not exceed 0.1% by weight in homogeneous materials. Where designed to be soldered at high temperatures, TI Pb-Free products are suitable for use in specified lead-free processes.

Pb-Free (RoHS Exempt): This component has a RoHS exemption for either 1) lead-based flip-chip solder bumps used between the die and package, or 2) lead-based die adhesive used between the die and leadframe. The component is otherwise considered Pb-Free (RoHS compatible) as defined above.

Green (RoHS & no Sb/Br): TI defines "Green" to mean Pb-Free (RoHS compatible), and free of Bromine (Br) and Antimony (Sb) based flame retardants (Br or Sb do not exceed 0.1% by weight in homogeneous material)

⁽³⁾ MSL, Peak Temp. -- The Moisture Sensitivity Level rating according to the JEDEC industry standard classifications, and peak solder temperature.

Important Information and Disclaimer:The information provided on this page represents TI's knowledge and belief as of the date that it is provided. TI bases its knowledge and belief on information provided by third parties, and makes no representation or warranty as to the accuracy of such information. Efforts are underway to better integrate information from third parties. TI has taken and continues to take reasonable steps to provide representative and accurate information but may not have conducted destructive testing or chemical analysis on incoming materials and chemicals. TI and TI suppliers consider certain information to be proprietary, and thus CAS numbers and other limited information may not be available for release.

In no event shall TI's liability arising out of such information exceed the total purchase price of the TI part(s) at issue in this document sold by TI to Customer on an annual basis.

PFC (S-PQFP-G80)

PLASTIC QUAD FLATPACK

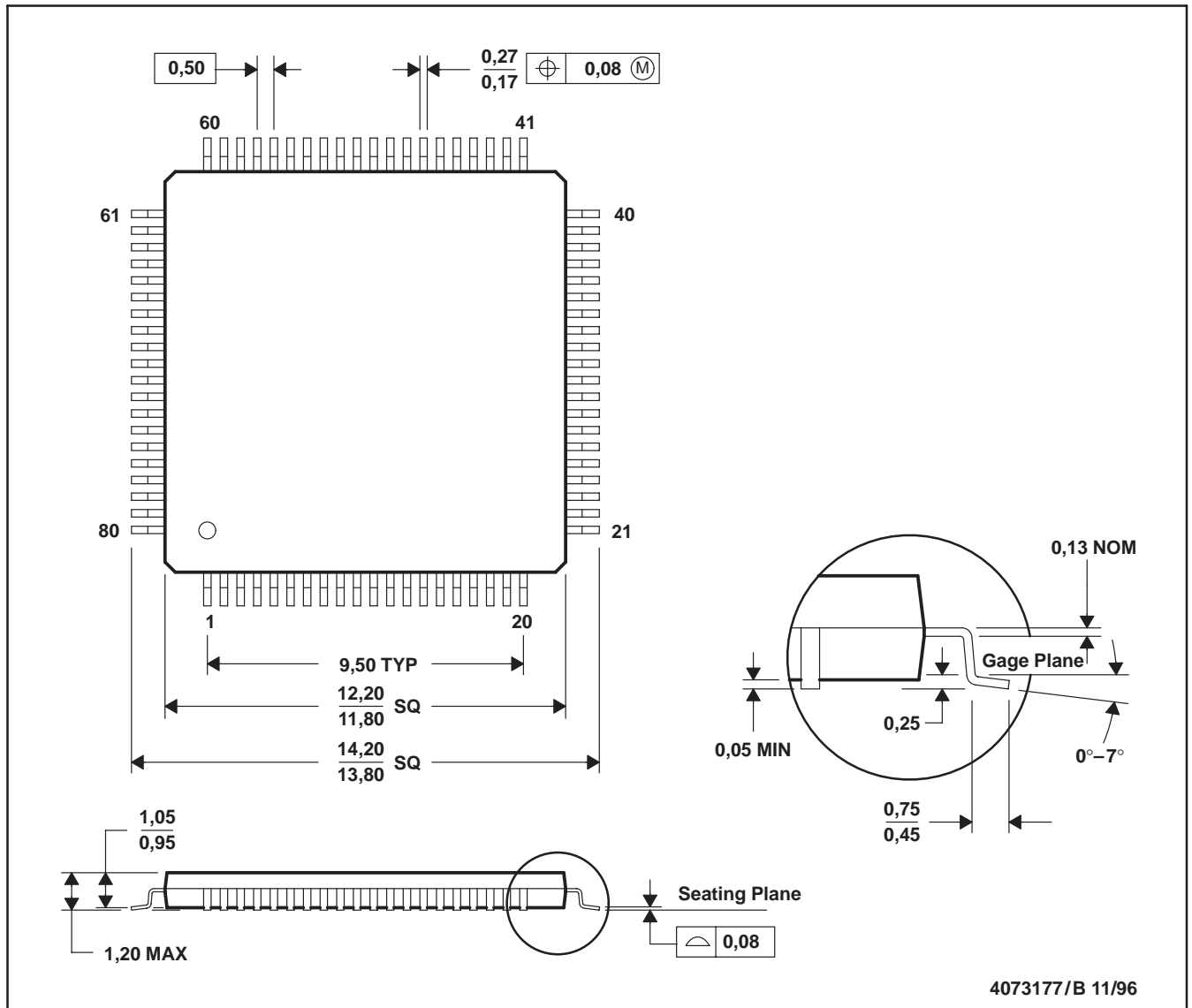

- NOTES: A. All linear dimensions are in millimeters.
 B. This drawing is subject to change without notice.
 C. Falls within JEDEC MS-026