

TOSHIBA Bi-CMOS Integrated Circuit Silicon Monolithic

TB6551FG, TB6551FAG

3-Phase Full-Wave Sine-Wave PWM Brushless Motor Controller

The TB6551FG/FAG is designed for motor fan applications for three-phase brushless DC (BLDC) motors.

Features

- Sine-wave PWM control
- Built-in triangular-wave generator
(Carrier cycle = $f_{OSC}/252$ (Hz))
- Built-in lead angle control function (0° to 58° in 32 steps)
- Built-in dead time function (setting $2.6 \mu\text{s}$ or $3.8 \mu\text{s}$)
- Bootstrap circuit compliant
- Over-current protection signal input pin
- Built-in regulator ($V_{ref} = 5 \text{ V}$ (typ.), 30 mA (max))
- Operating supply voltage range: $V_{CC} = 6 \text{ V}$ to 10 V

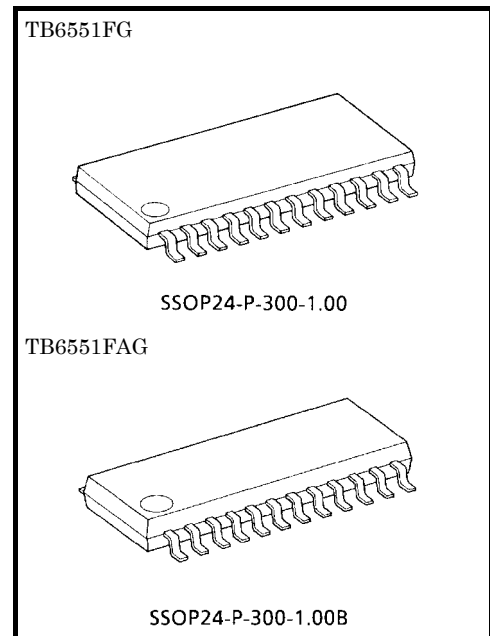

Weight:

SSOP24-P-300-1.00 : 0.33 g (typ.)

SSOP24-P-300-1.00B: 0.28 g (typ.)

Block Diagram

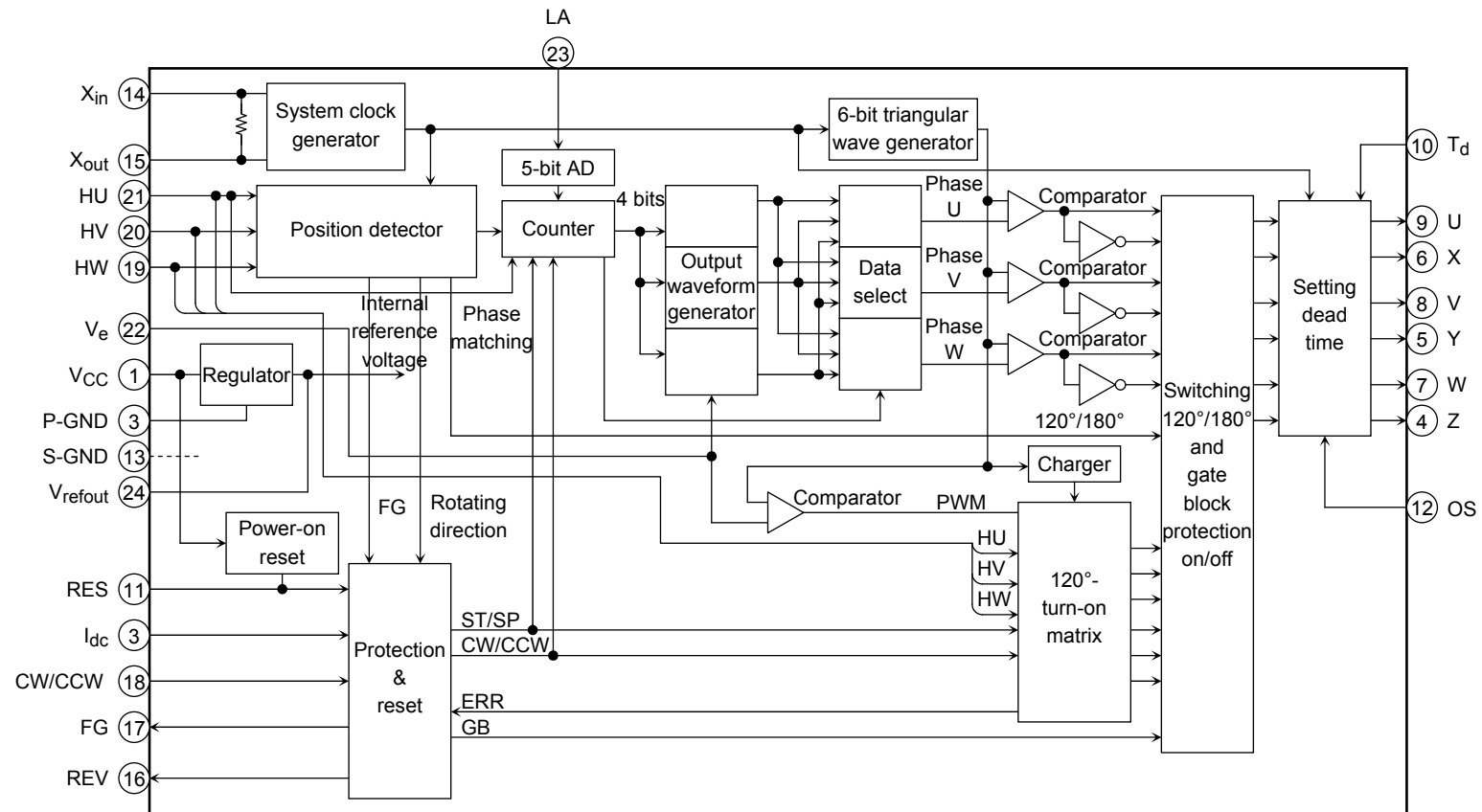

Pin Description

Pin No.	Symbol	Description	Remarks
21	HU	Positional signal input pin U	When positional signal is HHH or LLL, gate block protection operates. With built-in pull-up resistor
20	HV	Positional signal input pin V	
19	HW	Positional signal input pin W	
18	CW/CCW	Rotation direction signal input pin	L: Forward H: Reverse
11	RES	Reset-signal-input pin	L: Reset (output is non-active) Operation/Halt operation Also used for gate block protection
22	V _e	Inputs voltage instruction signal	With built-in pull-down resistor
23	LA	Lead angle setting signal input pin	Sets 0° to 58° in 32 steps
12	OS	Inputs output logic select signal	L: Active low H: Active high
3	I _{dc}	Inputs over-current-protection-signal	Inputs DC link current. Reference voltage: 0.5 V With built-in filter (≈ 1 μs)
14	X _{in}	Inputs clock signal	With built-in feedback resistor
15	X _{out}	Outputs clock signal	
24	V _{refout}	Outputs reference voltage signal	5 V (typ.), 30 mA (max)
17	FG	FG signal output pin	Outputs 3PPR of positional signal
16	REV	Reverse rotation detection signal	Detects reverse rotation.
9	U	Outputs turn-on signal	Select active high or active low using the output logic select pin.
8	V	Outputs turn-on signal	
7	W	Outputs turn-on signal	
6	X	Outputs turn-on signal	
5	Y	Outputs turn-on signal	
4	Z	Outputs turn-on signal	
1	V _{CC}	Power supply voltage pin	V _{CC} = 6 V to 10 V
10	T _d	Inputs setting dead time	L: 3.8 μs, H or Open: 2.6 μs
2	P-GND	Ground for power supply	Ground pin
13	S-GND	Ground for signals	Ground pin

Input/Output Equivalent Circuits

Pin Description	Symbol	Input/Output Signal	Input/Output Internal Circuit
Positional signal input pin U	HU	Digital	
Positional signal input pin V	HV	With Schmitt trigger Hysteresis 300 mV (typ.)	
Positional signal input pin W	HW	L: 0.8 V (max) H: $V_{refout} - 1$ V (min)	
Forward/reverse switching input pin	CW/CCW	Digital	
L: Forward (CW) H: Reverse (CCW)		With Schmitt trigger Hysteresis 300 mV (typ.) L: 0.8 V (max) H: $V_{refout} - 1$ V (min)	
Reset input	RES	Digital	
L: Stops operation (reset). H: Operates.		With Schmitt trigger Hysteresis 300 mV (typ.) L: 0.8 V (max) H: $V_{refout} - 1$ V (min)	
Voltage instruction signal input pin	V_e	Analog	
Turn on the lower transistor at 0.2 V or less. (X, Y, Z pins: On duty of 8%)		Input range 0 V to 5.0 V Input voltage of V_{refout} or higher is clipped to V_{refout} .	
Lead angle setting signal input pin	LA	Analog	
0 V: 0° 5 V: 58° (5-bit AD)		Input range 0 V to 5.0 V Input voltage of V_{refout} or higher is clipped to V_{refout} .	

Pin Description	Symbol	Input/Output Signal	Input/Output Internal Circuit
Setting dead time input pin L: 3.8 μ s H or Open: 2.6 μ s	T_d	Digital L: 0.8 V (max) H: $V_{refout} - 1$ V (min)	
Output logic select signal input pin L: Active low H: Active high	OS	Digital L: 0.8 V (max) H: $V_{refout} - 1$ V (min)	
Over-current protection signal input pin	I_{dc}	Analog Gate block protected at 0.5 V or higher (released at carrier cycle)	
Clock signal input pin	X_{in}	Operating range 2 MHz to 8 MHz (ceramic oscillation)	
Clock signal output pin	X_{out}		
Reference voltage signal output pin	V_{refout}	5 ± 0.5 V (max 30 mA)	

Pin Description	Symbol	Input/Output Signal	Input/Output Internal Circuit
Reverse-rotation-detection signal output pin	REV	Digital Push-pull output: ± 1 mA (max)	
FG signal output pin	FG	Digital Push-pull output: ± 1 mA (max)	
Turn-on signal output pin U Turn-on signal output pin V Turn-on signal output pin W Turn-on signal output pin X Turn-on signal output pin Y Turn-on signal output pin Z	U V W X Y Z	Analog Push-pull output: ± 2 mA (max) L: 0.78 V (max) H: $V_{refout} - 0.78$ V (min)	

Absolute Maximum Ratings ($T_a = 25^\circ\text{C}$)

Characteristics	Symbol	Rating	Unit	
Supply voltage	V_{CC}	12	V	
Input voltage	$V_{in(1)}$	-0.3 to V_{CC} (Note 1)	V	
	$V_{in(2)}$	-0.3 to 5.5 (Note 2)		
Turn-on signal output current	I_{OUT}	2	mA	
Power Dissipation	P_D	FG	0.9 (Note 3)	W
		FAG	1.0 (Note 3)	
Operating temperature	T_{opr}	-30 to 115 (Note 4)	$^\circ\text{C}$	
Storage temperature	T_{stg}	-50 to 150	$^\circ\text{C}$	

Note 1: $V_{in(1)}$ pin: V_e , LA

Note 2: $V_{in(2)}$ pin: HU, HV, HW, CW/CCW, RES, OS, I_{dc} , T_d

Note 3: When mounted on a PCB (universal 50 mm × 50 mm × 1.6 mm, Cu 30%)

Note 4: Operating temperature range is determined by the $P_D - T_a$ characteristic.

Note 5: Using continuously under heavy loads (e.g. the application of high temperature/current/voltage and the significant change in temperature, etc.) may cause this product to decrease in the reliability significantly even if the operating conditions (i.e. operating temperature/current/voltage, etc.) are within the absolute maximum ratings.

Please design the appropriate reliability upon reviewing the Toshiba Semiconductor Reliability Handbook ("Handling Precautions"/"Derating Concept and Methods") and individual reliability data (i.e. reliability test report and estimated failure rate, etc).

Operating Conditions ($T_a = 25^\circ\text{C}$)

Characteristics	Symbol	Min	Typ.	Max	Unit
Supply voltage	V_{CC}	6	7	10	V
Ceramic oscillation frequency	X_{in}	2	4	8	MHz

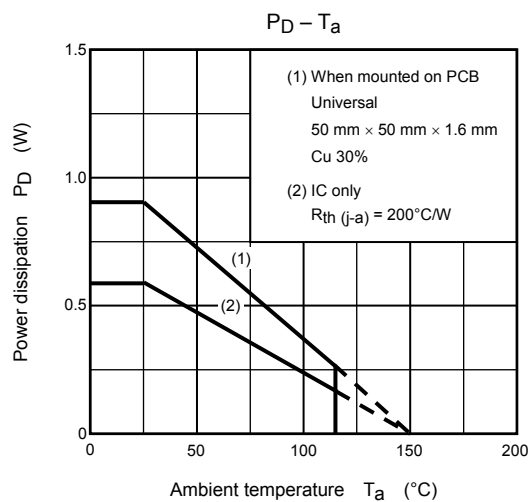

Electrical Characteristics (T_a = 25°C, V_{CC} = 7 V)

Characteristics	Symbol	Test Circuit	Test Condition	Min	Typ.	Max	Unit
Supply current	I _{CC}	—	V _{refout} = open	—	3	6	mA
Input current	I _{in} (1)	—	V _{in} = 5 V V _e , LA	—	20	40	μA
	I _{in} (2)-1		V _{in} = 0 V HU, HV, HW	-40	-20	—	
	I _{in} (2)-2		V _{in} = 0 V CW/CCW, OS, T _d	-80	-40	—	
	I _{in} (2)-3		V _{in} = 5 V RES	—	40	80	
Input voltage	V _{in}	High	HU, HV, HW, CW/CCW, RES, OS, T _d	V _{refout} - 1	—	V _{refout}	V
		Low		—	—	0.8	
Input hysteresis voltage	V _H	—	HU, HV, HW, CW/CCW, RES	—	0.3	—	V
Output voltage	V _{OUT} (H)-1	—	I _{OUT} = 2 mA U, V, W, X, Y, Z	V _{refout} - 0.78	V _{refout} - 0.4	—	V
	V _{OUT} (L)-1		I _{OUT} = -2 mA U, V, W, X, Y, Z	—	0.4	0.78	
	V _{REV} (H)		I _{OUT} = 1 mA REV	V _{refout} - 1.0	V _{refout} - 0.5	—	
	V _{REV} (L)		I _{OUT} = -1 mA REV	—	0.5	1.0	
	V _{FG} (H)		I _{OUT} = 1 mA FG	V _{refout} - 1.0	V _{refout} - 0.5	—	
	V _{FG} (L)		I _{OUT} = -1 mA FG	—	0.5	1.0	
	V _{refout}		I _{OUT} = 30 mA V _{refout}	4.5	5.0	5.5	
Output leakage current	I _L (H)	—	V _{OUT} = 0 V U, V, W, X, Y, Z	—	0	10	μA
	I _L (L)		V _{OUT} = 3.5 V U, V, W, X, Y, Z	—	0	10	
Output off-time by upper/lower transistor (Note 6)	T _{OFF} (H)	—	T _d = High or OPEN, X _{in} = 4.19 MHz, I _{OUT} = ± 2 mA, OS = High/Low	2.2	2.6	—	μs
	T _{OFF} (L)		T _d = Low, X _{in} = 4.19 MHz, I _{OUT} = ± 2 mA, OS = High/Low	3.0	3.8	—	
Over-current detection	V _{dc}	—	I _{dc}	0.46	0.5	0.54	V
Lead angle correction	T _{LA} (0)	—	L _A = 0 V or Open, Hall IN = 100 Hz	—	0	—	°
	T _{LA} (2.5)		L _A = 2.5 V, Hall IN = 100 Hz	27.5	32	34.5	
	T _{LA} (5)		L _A = 5 V, Hall IN = 100 Hz	53.5	59	62.5	
V _{CC} monitor	V _{CC} (H)	—	Output start operation point	4.2	4.5	4.8	V
	V _{CC} (L)		No output operation point	3.7	4.0	4.3	
	V _H		Input hysteresis width	—	0.5	—	

Note 6: T_{OFF}
OS = High

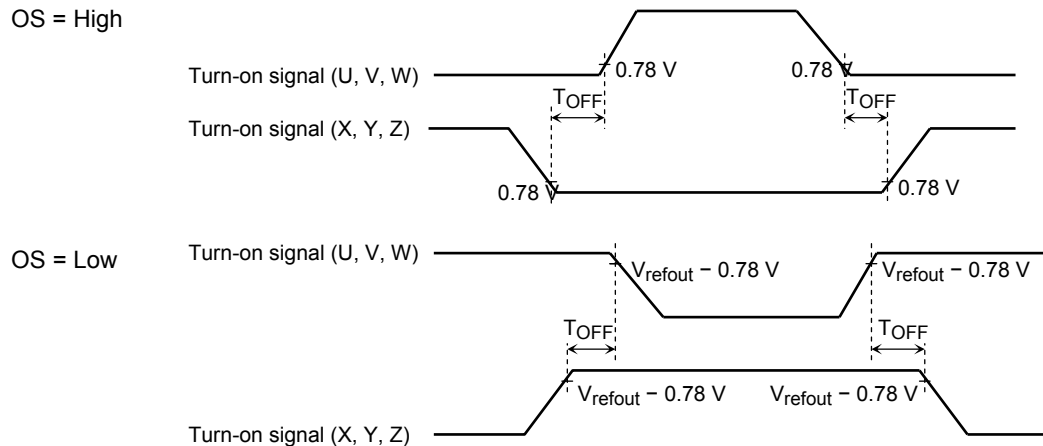

Functional Description

Basic operation

On start-up, the motor is driven by the square-wave turn-on signal based on a positional signal. When the positional signal reaches number of rotations $f = 5$ Hz or higher, the rotor position is inferred from the positional signal and a modulation wave is generated. The modulation wave and the triangular wave are compared; the sine-wave PWM signal is then generated and the motor is driven.

From start to 5 Hz: When driven by square wave (120° turn-on) $f = f_{OSC}/(2^{12} \times 32 \times 6)$

5 Hz or higher: When driven by sine-wave PWM (180° turn-on) When $f_{OSC} = 4$ MHz, approx. 5 Hz

Function to stabilize bootstrap voltage

- (1) When voltage instruction is input at $V_e \leq 0.2$ V:
The lower transistor is turned on at the regular (carrier) cycle. (On duty is approx. 8%.)
- (2) When voltage instruction is input at $V_e > 0.2$ V:
During sine-wave drive, the drive signal is output as it is.
During square-wave drive, the lower transistor is forcibly turned on at the regular (carrier) cycle. (On duty is approx. 8%.)

Note: At startup, to charge the upper transistor gate power supply, turn the lower transistor on for a fixed time with $V_e \leq 0.2$ V.

Dead time function: upper/lower transistor output off-time

When the motor is driven by a sine-wave PWM, dead time is generated digitally in the IC to prevent any short circuit caused by the simultaneous turning on of upper and lower external power devices.

When a square wave is generated in full duty cycle mode, the dead time function is turned on to prevent a short circuit.

T _d Pin	Internal Counter	T _{OFF}
High or Open	11/f _{OSC}	2.6 μs
Low	16/f _{OSC}	3.8 μs

T_{OFF} values above are obtained when $f_{OSC} = 4.19$ MHz.
f_{OSC} = reference clock (ceramic oscillation)

Correcting lead angle

The lead angle can be corrected in the turn-on signal range from 0 to 58° in relation to the induced voltage.

Analog input from LA pin (0 V to 5 V divided by 32):

0 V = 0°

5 V = 58° (when more than 5 V is input, 58°)

Setting carrier frequency

This feature sets the triangular wave cycle (carrier cycle) necessary for generating the PWM signal. (The triangular wave is used for forcibly turning on the lower transistor when the motor is driven by square wave.)

Carrier cycle = $f_{OSC}/252$ (Hz)

f_{OSC} = Reference clock (ceramic oscillation)

Switching the output of turn-on signal

This function switches the output of the turn-on signal between high and low.

Pin OS:

High = active high

Low = active low

Outputting reverse rotation detection signal

The direction of motor rotation is detected for every electrical angle of 360°. (The output is high immediately after reset.)

The REV terminal increases to a 180° turn-on mode at the time of low (Hall IN ≥ 5 Hz).

CW/CCW Pin	Actual Motor Rotating Direction	REV Pin
Low (CW)	CW (forward)	Low
	CCW (reverse)	High
High (CCW)	CW (forward)	High
	CCW (reverse)	Low

Protecting input pin

1. Over-current protection (Pin I_{dc})

When the DC-link-current exceeds the internal reference voltage, gate block protection is performed. Over-current protection is released for each carrier frequency.

Reference voltage = 0.5 V (typ.)

2. Gate block protection (Pin RES)

When the input signal level is Low, the output is turned off; when the signal is High, the output is restarted.

Abnormalities are detected externally, and the signal is input to the pin RES.

RES Pin	OS Pin	Output Turn-on Signal (U, V, W, X, Y, Z)
Low	Low	High
	High	Low

(When RES = Low, bootstrap capacitor charging stops.)

3. Internal protection

- Positional signal abnormality protection

When the positional signal is HHH or LLL, the output is turned off; otherwise, the output is restarted.

- Low power supply voltage protection (V_{CC} monitor)

Outside the operating voltage range, the turn-on signal output is kept at high impedance to prevent damage caused by short-circuiting of power components when the power supply is turned on or off.

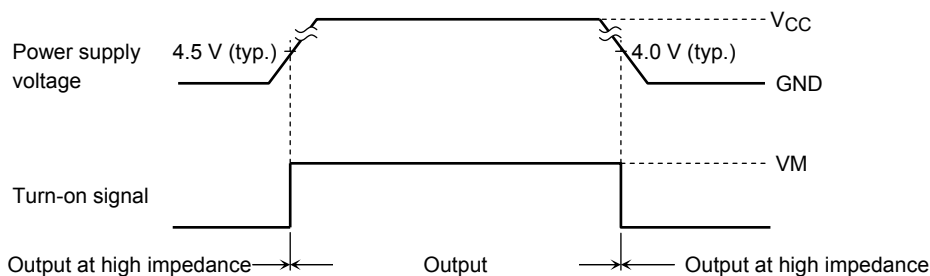

Operation Flow

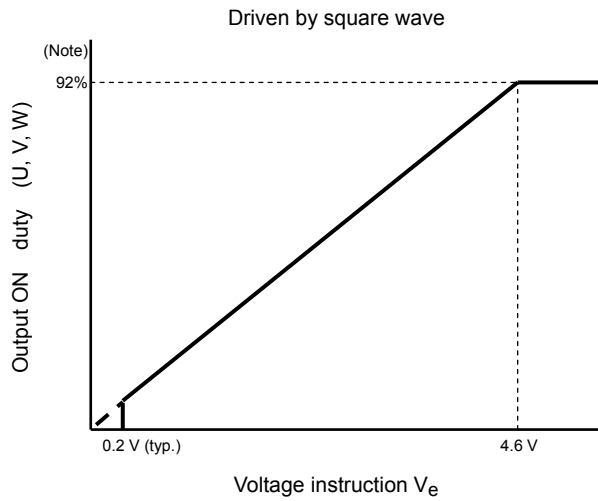
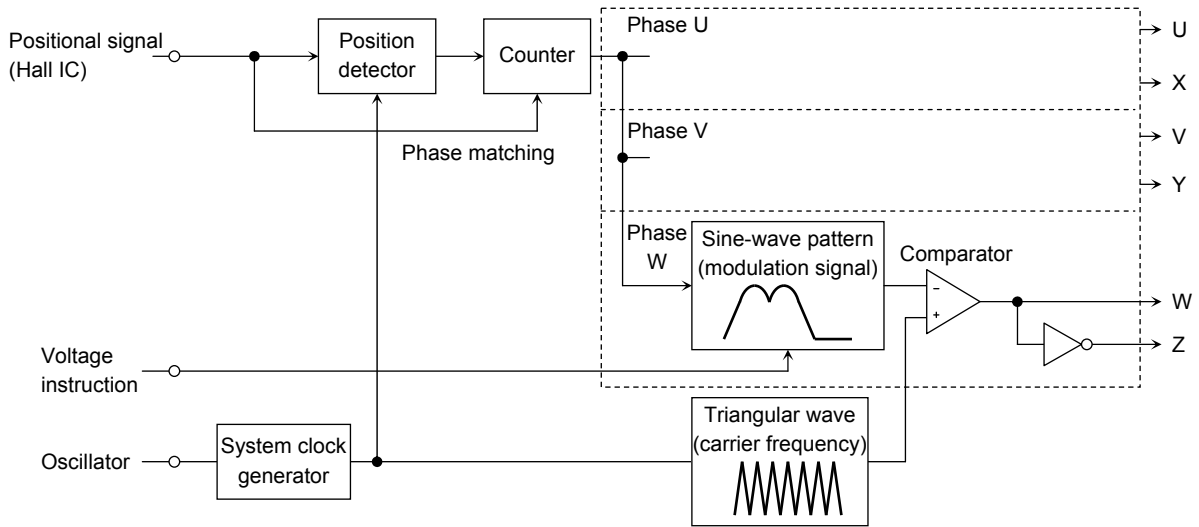

Note: Output ON time is decreased by the dead time (carrier frequency \times 92% - $T_d \times 2$).

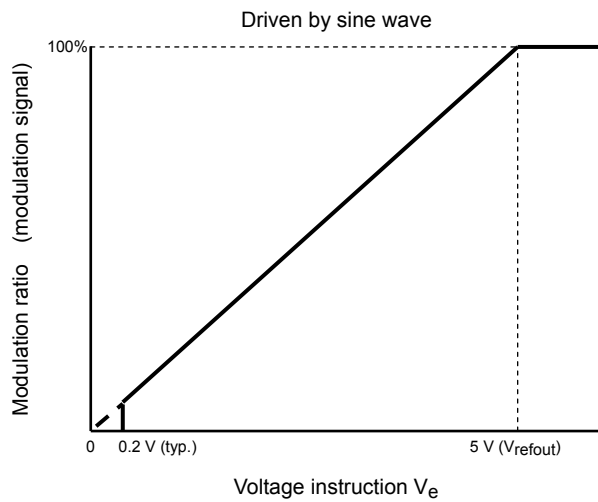

The modulation waveform is generated using Hall signals. The modulation waveform is then compared with the triangular wave and a sine-wave PWM signal is generated.

The time (electrical angle: 60°) from the rising (or falling) edges of the three Hall signals to the next falling (or rising) edges is counted. The counted time is used as the data for the next 60° phase of the modulation waveform.

There are 32 items of data for the 60° phase of the modulation waveform. The time width of one data item is 1/32 of the time width of the 60° phase of the previous modulation waveform. The modulation waveform moves forward by this width.

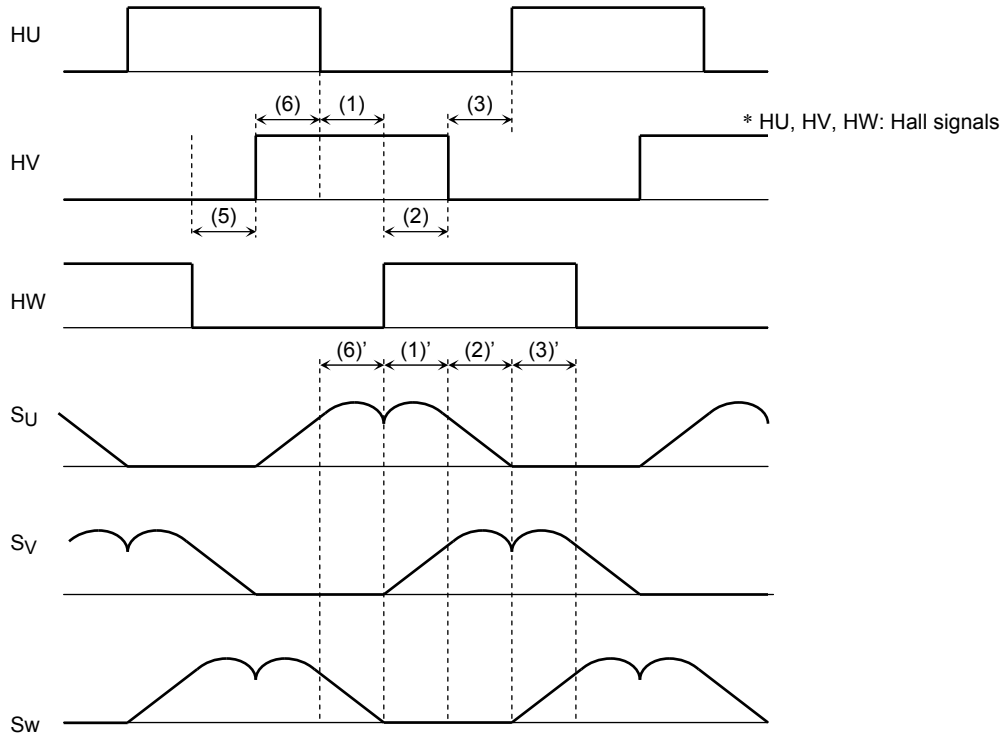

In the above diagram, the modulation waveform (1)' data moves forward by the 1/32 time width of the time (1) from HU: ↓ to HW: ↑. Similarly, data (2)' moves forward by the 1/32 time width of the time (2) from HW: ↑ to HV: ↓.

If the next edge does not occur after the 32 data items end, the next 32 data items move forward by the same time width until the next edge occurs.

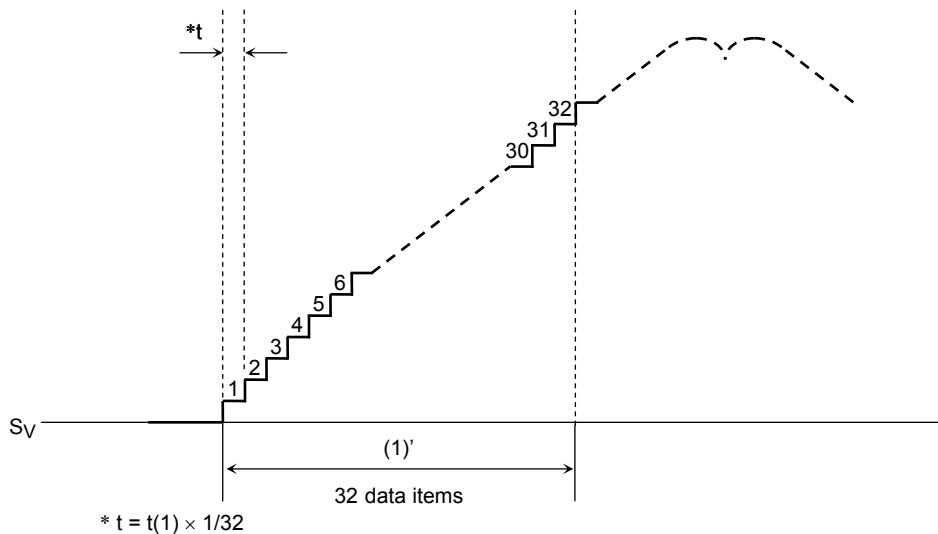

The modulation wave is brought into phase with every edge of the Hall signal.

The modulation wave is reset in synchronization with the rising and falling edges of the Hall signal at every electrical angle of 60°. Thus, when the Hall device is not placed in the correct position or during accelerating or decelerating, the modulation waveform is not continuous at every reset.

Timing Charts

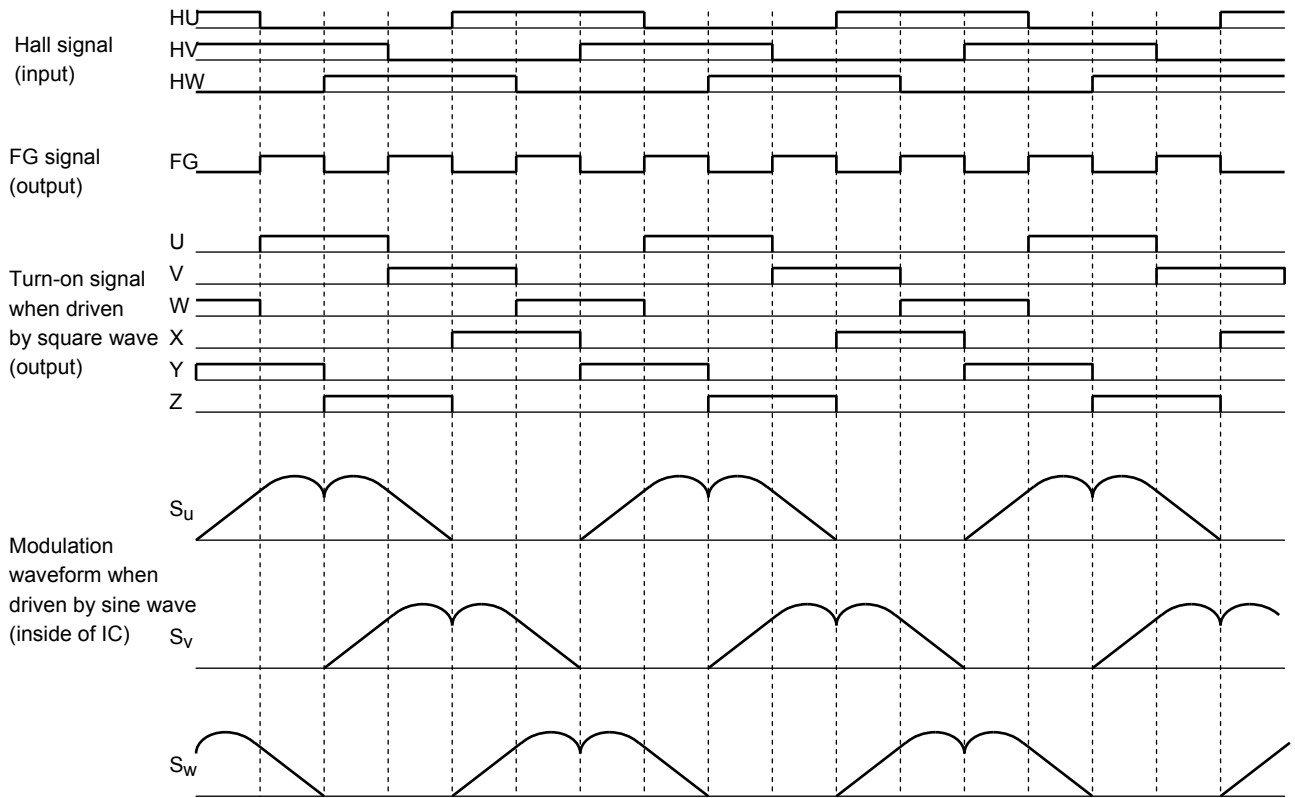

Forward

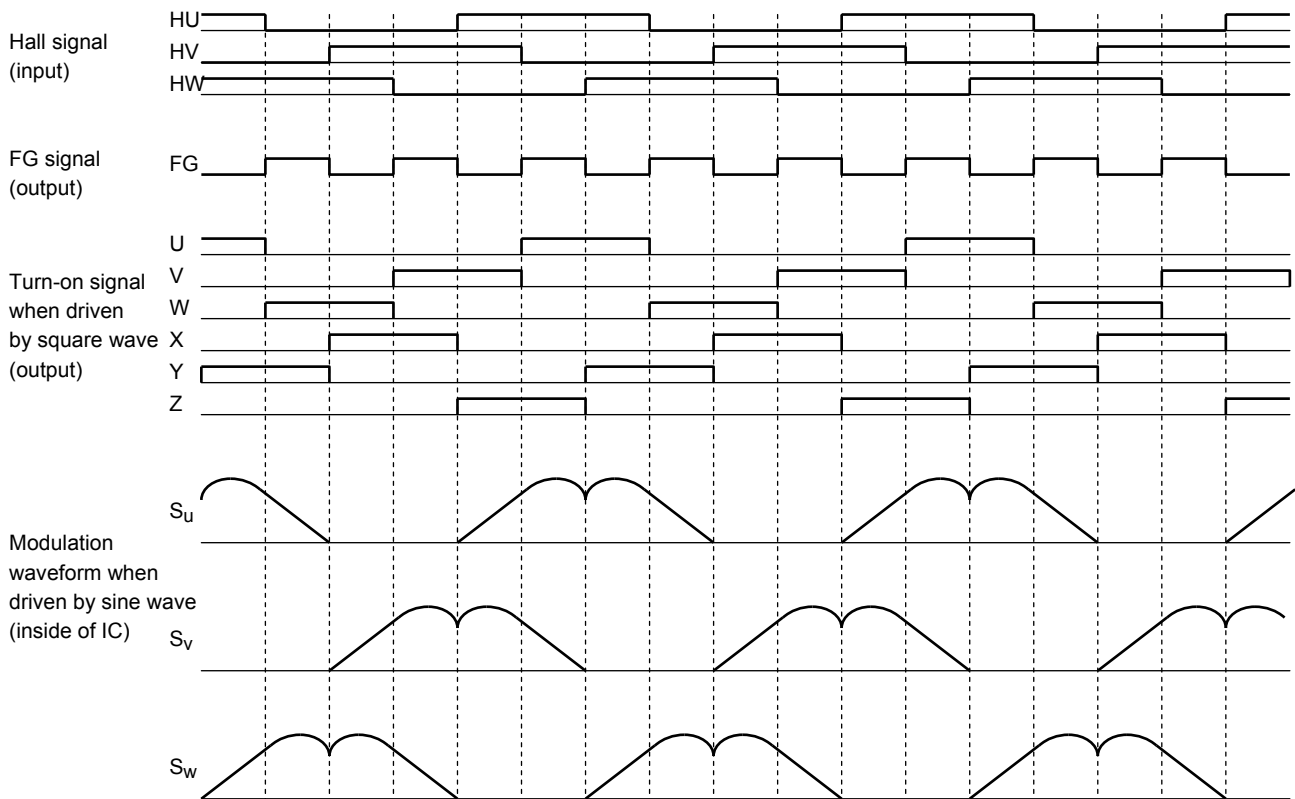

Reverse

Operating Waveform When Driven by Square Wave (CW/CCW = Low, OS = High)

Hall signal

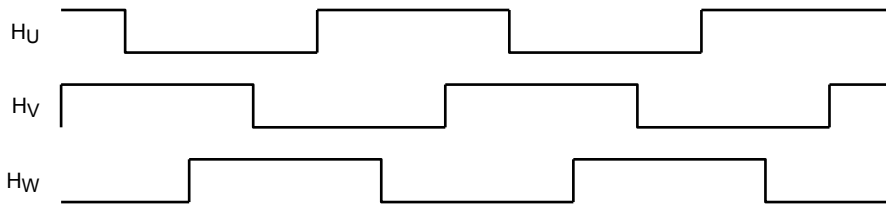

Output waveform

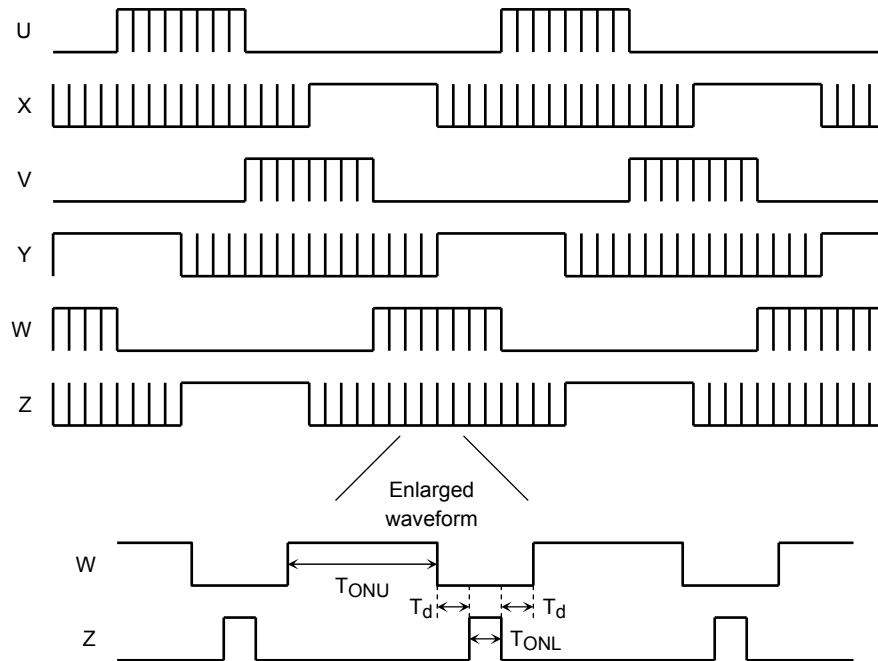

To stabilize the bootstrap voltage, the lower outputs (X, Y, and Z) are always turned on at the carrier cycle even during off time. At that time, the upper outputs (U, V, and W) are assigned dead time and turned off at the timing when the lower outputs are turned on. (T_d varies with input V_e .)

Carrier cycle = $f_{OSC}/252$ (Hz)

Dead time: $T_d = 16/f_{OSC}$ (s) (when $V_e = 4.6$ V or more)

$T_{ONL} = \text{carrier cycle} \times 8\%$ (s) (uniform regardless of V_e input)

When the motor is driven by a square wave, acceleration or deceleration is determined by voltage V_e . The motor accelerates or decelerates according to the On duty of T_{ONU} . (See the diagram for output On duty on page 11.)

Note: The motor is driven by a square wave if REV = High, i.e., if the Hall signals at start-up are 5 Hz ($f_{OSC} = 4$ MHz) or lower and the motor is rotating in the reverse direction to that of the TB6551FG/FAG setting.

Operating Waveform When Driven by Sine-Wave PWM (CW/CCW = Low, OS = High)

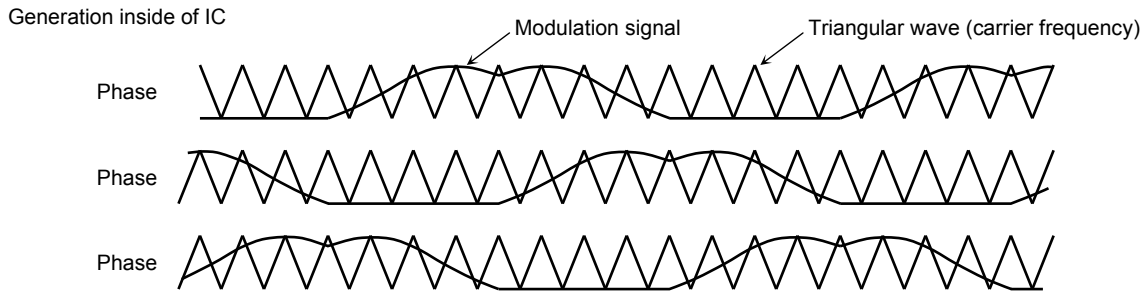

Output waveform

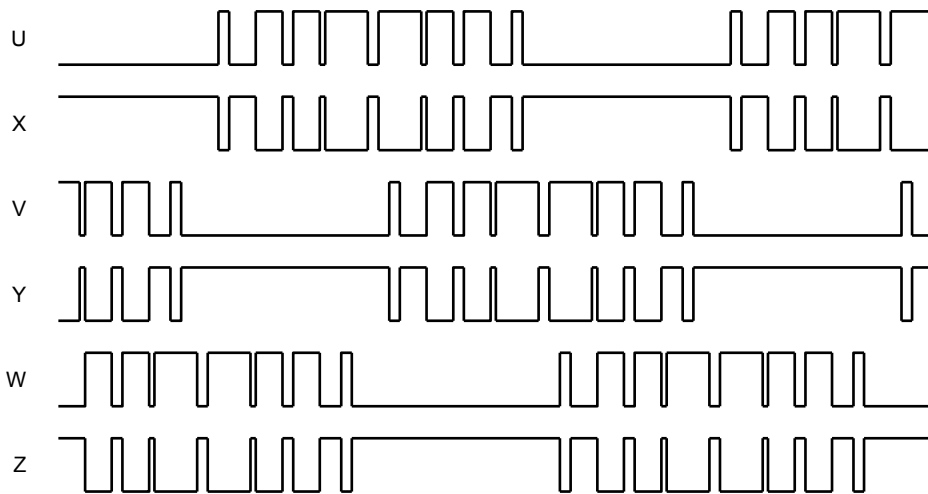

Inter-line voltage

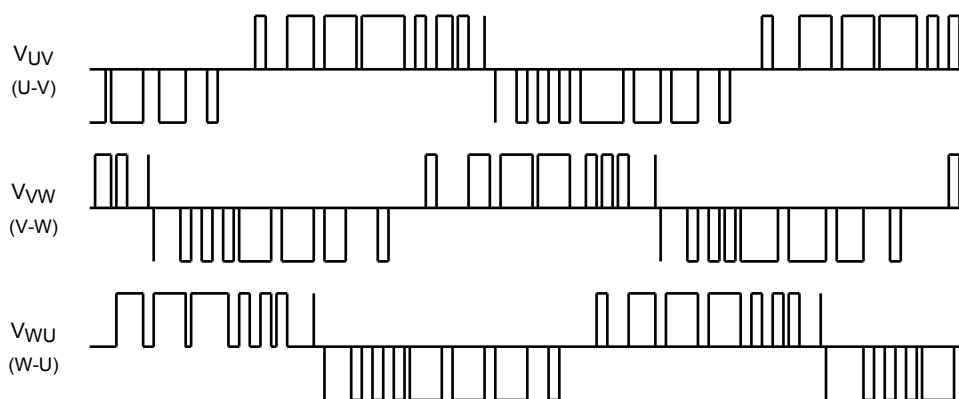

When the motor is driven by a sine wave, the motor is accelerated or decelerated according to the On duty of TONU when the amplitude of the modulation symbol changes by voltage V_e (see the diagram of output On duty on page 11):

$$\text{Triangular wave frequency} = \text{carrier frequency} = f_{OSC}/252 \text{ (Hz)}.$$

Note: The motor is driven by a sine wave if REV = Low, i.e., if the Hall signals at start-up are 5 Hz ($f_{OSC} = 4 \text{ MHz}$) or higher and the motor is rotating in the same direction as that of the TB6551FG/FAG setting.

Example of Application Circuit

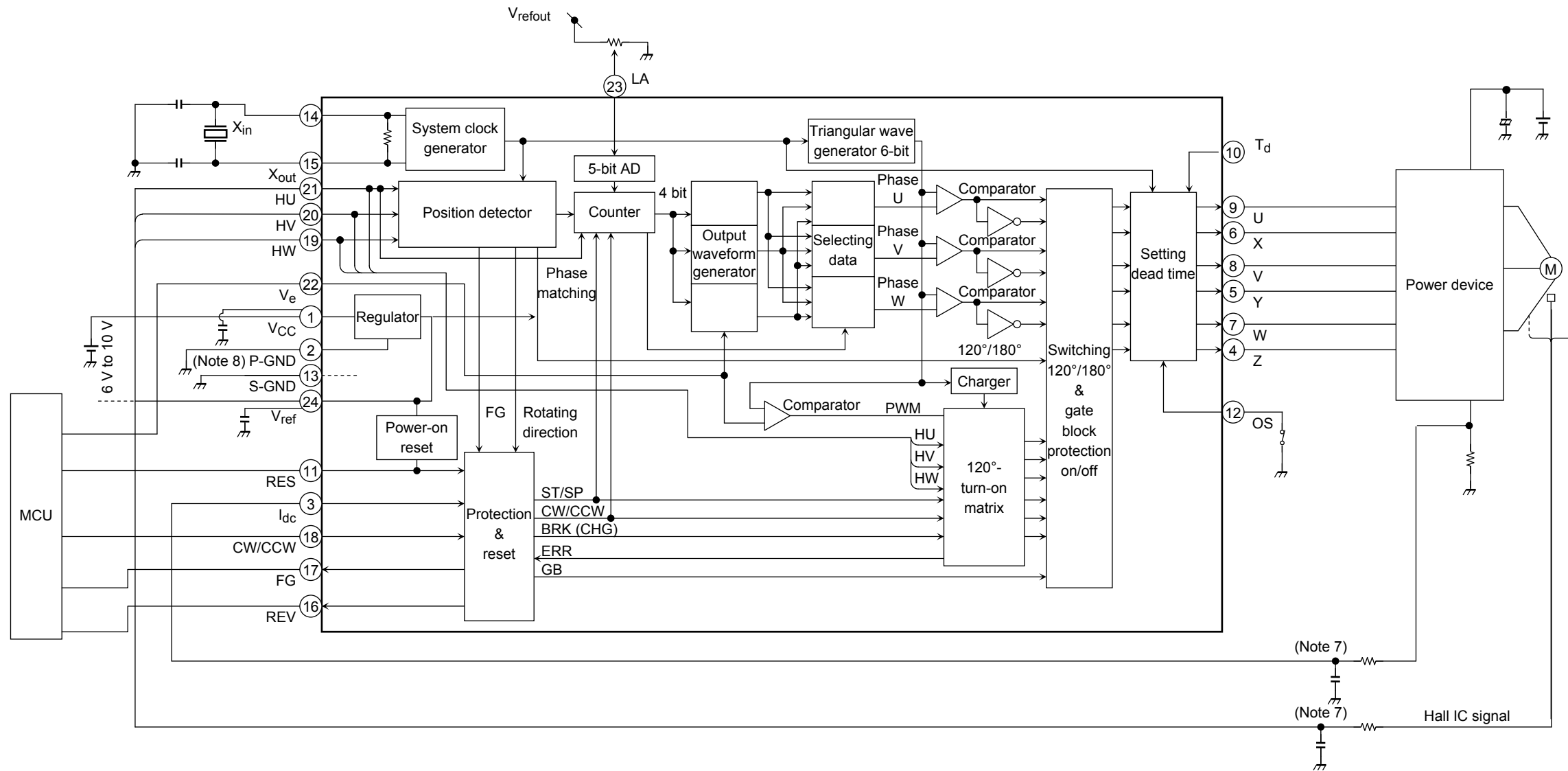

Note 7: Connect as required to the ground to prevent IC malfunction due to noise.

Note 8: Connect P-GND to signal ground on the application circuit.

Note 9: Utmost care is necessary in the design of the output, V_{CC}, VM, and GND lines since the IC may be destroyed by short-circuiting between outputs, air contamination faults, or faults due to improper grounding, or by short-circuiting between contiguous pins.

Package Dimensions

SSOP24-P-300-1.00

Unit : mm

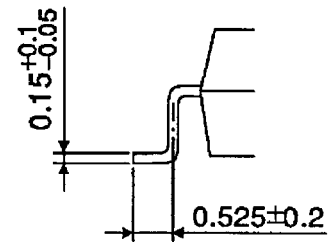
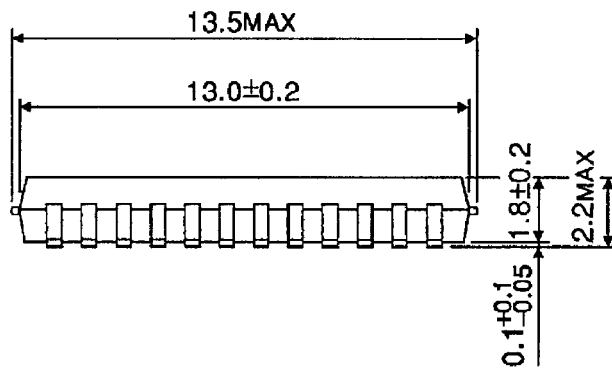
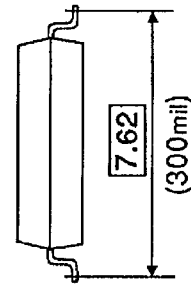
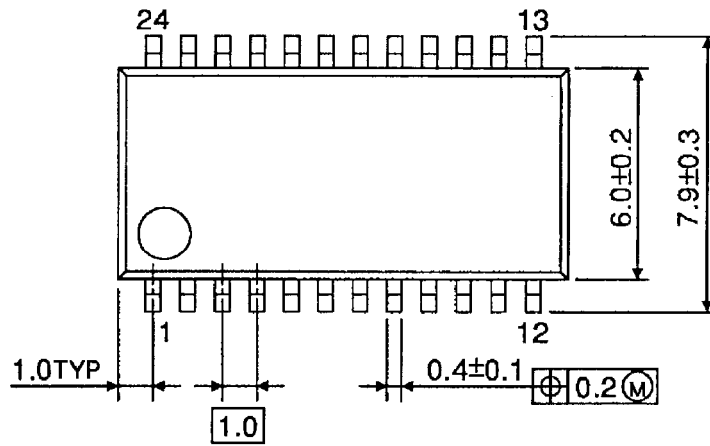

Weight: 0.33 g (typ.)

Package Dimensions

SSOP24-P-300-1.00B

Unit : mm

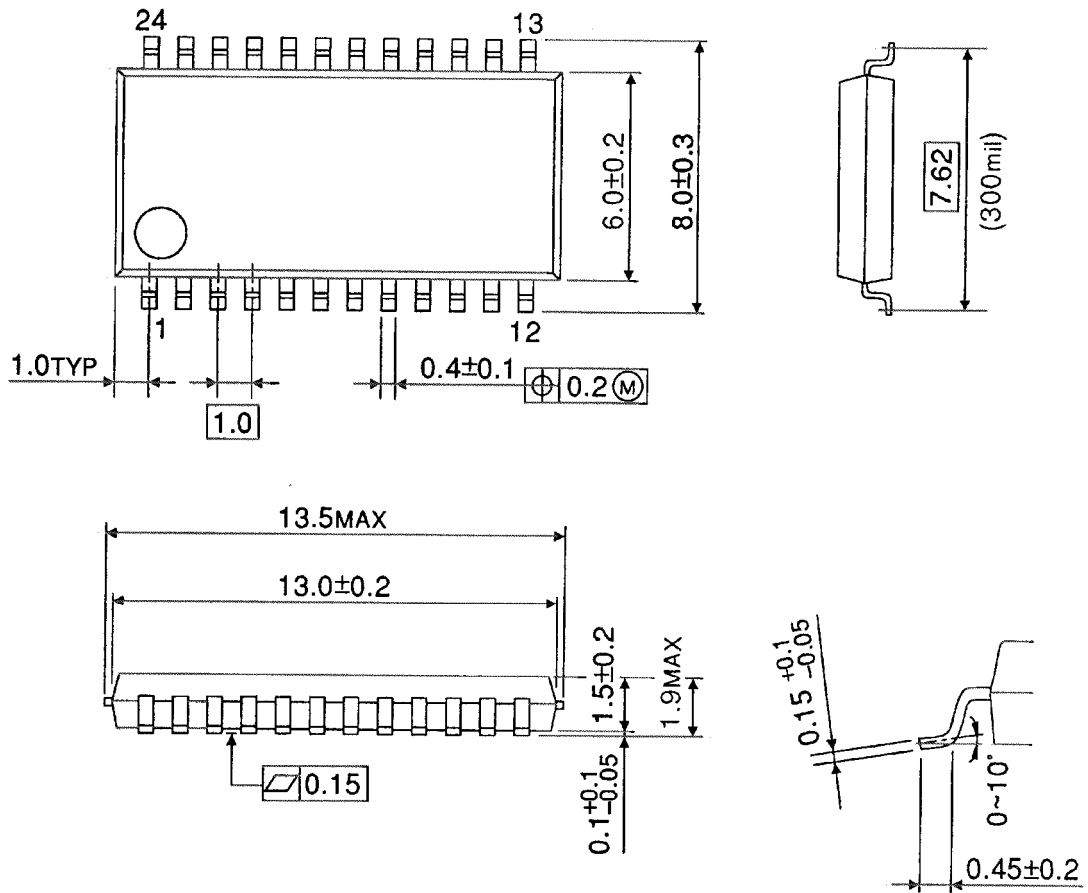

Weight: 0.28 g (typ.)

Notes on Contents

1. Block Diagrams

Some of the functional blocks, circuits, or constants in the block diagram may be omitted or simplified for explanatory purposes.

2. Equivalent Circuits

The equivalent circuit diagrams may be simplified or some parts of them may be omitted for explanatory purposes.

3. Timing Charts

Timing charts may be simplified for explanatory purposes.

4. Application Circuits

The application circuits shown in this document are provided for reference purposes only. Thorough evaluation is required, especially at the mass production design stage.

Toshiba does not grant any license to any industrial property rights by providing these examples of application circuits.

5. Test Circuits

Components in the test circuits are used only to obtain and confirm the device characteristics. These components and circuits are not guaranteed to prevent malfunction or failure from occurring in the application equipment.

IC Usage Considerations

Notes on handling of ICs

- [1] The absolute maximum ratings of a semiconductor device are a set of ratings that must not be exceeded, even for a moment. Do not exceed any of these ratings.
Exceeding the rating(s) may cause the device breakdown, damage or deterioration, and may result injury by explosion or combustion.
- [2] Do not insert devices in the wrong orientation or incorrectly.
Make sure that the positive and negative terminals of power supplies are connected properly.
Otherwise, the current or power consumption may exceed the absolute maximum rating, and exceeding the rating(s) may cause the device breakdown, damage or deterioration, and may result injury by explosion or combustion.
In addition, do not use any device that is applied the current with inserting in the wrong orientation or incorrectly even just one time.

Points to remember on handling of ICs**(1) Over current Protection Circuit**

Over current protection circuits (referred to as current limiter circuits) do not necessarily protect ICs under all circumstances. If the over current protection circuits operate against the over current, clear the over current status immediately.

Depending on the method of use and usage conditions, such as exceeding absolute maximum ratings can cause the over current protection circuit to not operate properly or IC breakdown before operation. In addition, depending on the method of use and usage conditions, if over current continues to flow for a long time after operation, the IC may generate heat resulting in breakdown.

(2) Back-EMF

When a motor rotates in the reverse direction, stops or slows down abruptly, a current flow back to the motor's power supply due to the effect of back-EMF. If the current sink capability of the power supply is small, the device's motor power supply and output pins might be exposed to conditions beyond absolute maximum ratings. To avoid this problem, take the effect of back-EMF into consideration in system design

RESTRICTIONS ON PRODUCT USE

- Toshiba Corporation, and its subsidiaries and affiliates (collectively "TOSHIBA"), reserve the right to make changes to the information in this document, and related hardware, software and systems (collectively "Product") without notice.
- This document and any information herein may not be reproduced without prior written permission from TOSHIBA. Even with TOSHIBA's written permission, reproduction is permissible only if reproduction is without alteration/omission.
- Though TOSHIBA works continually to improve Product's quality and reliability, Product can malfunction or fail. Customers are responsible for complying with safety standards and for providing adequate designs and safeguards for their hardware, software and systems which minimize risk and avoid situations in which a malfunction or failure of Product could cause loss of human life, bodily injury or damage to property, including data loss or corruption. Before customers use the Product, create designs including the Product, or incorporate the Product into their own applications, customers must also refer to and comply with (a) the latest versions of all relevant TOSHIBA information, including without limitation, this document, the specifications, the data sheets and application notes for Product and the precautions and conditions set forth in the "TOSHIBA Semiconductor Reliability Handbook" and (b) the instructions for the application with which the Product will be used with or for. Customers are solely responsible for all aspects of their own product design or applications, including but not limited to (a) determining the appropriateness of the use of this Product in such design or applications; (b) evaluating and determining the applicability of any information contained in this document, or in charts, diagrams, programs, algorithms, sample application circuits, or any other referenced documents; and (c) validating all operating parameters for such designs and applications. **TOSHIBA ASSUMES NO LIABILITY FOR CUSTOMERS' PRODUCT DESIGN OR APPLICATIONS.**
- **PRODUCT IS NEITHER INTENDED NOR WARRANTED FOR USE IN EQUIPMENTS OR SYSTEMS THAT REQUIRE EXTRAORDINARILY HIGH LEVELS OF QUALITY AND/OR RELIABILITY, AND/OR A MALFUNCTION OR FAILURE OF WHICH MAY CAUSE LOSS OF HUMAN LIFE, BODILY INJURY, SERIOUS PROPERTY DAMAGE AND/OR SERIOUS PUBLIC IMPACT ("UNINTENDED USE").** Except for specific applications as expressly stated in this document, Unintended Use includes, without limitation, equipment used in nuclear facilities, equipment used in the aerospace industry, medical equipment, equipment used for automobiles, trains, ships and other transportation, traffic signaling equipment, equipment used to control combustions or explosions, safety devices, elevators and escalators, devices related to electric power, and equipment used in finance-related fields. **IF YOU USE PRODUCT FOR UNINTENDED USE, TOSHIBA ASSUMES NO LIABILITY FOR PRODUCT.** For details, please contact your TOSHIBA sales representative.
- Do not disassemble, analyze, reverse-engineer, alter, modify, translate or copy Product, whether in whole or in part.
- Product shall not be used for or incorporated into any products or systems whose manufacture, use, or sale is prohibited under any applicable laws or regulations.
- The information contained herein is presented only as guidance for Product use. No responsibility is assumed by TOSHIBA for any infringement of patents or any other intellectual property rights of third parties that may result from the use of Product. No license to any intellectual property right is granted by this document, whether express or implied, by estoppel or otherwise.
- **ABSENT A WRITTEN SIGNED AGREEMENT, EXCEPT AS PROVIDED IN THE RELEVANT TERMS AND CONDITIONS OF SALE FOR PRODUCT, AND TO THE MAXIMUM EXTENT ALLOWABLE BY LAW, TOSHIBA (1) ASSUMES NO LIABILITY WHATSOEVER, INCLUDING WITHOUT LIMITATION, INDIRECT, CONSEQUENTIAL, SPECIAL, OR INCIDENTAL DAMAGES OR LOSS, INCLUDING WITHOUT LIMITATION, LOSS OF PROFITS, LOSS OF OPPORTUNITIES, BUSINESS INTERRUPTION AND LOSS OF DATA, AND (2) DISCLAIMS ANY AND ALL EXPRESS OR IMPLIED WARRANTIES AND CONDITIONS RELATED TO SALE, USE OF PRODUCT, OR INFORMATION, INCLUDING WARRANTIES OR CONDITIONS OF MERCHANTABILITY, FITNESS FOR A PARTICULAR PURPOSE, ACCURACY OF INFORMATION, OR NONINFRINGEMENT.**
- Do not use or otherwise make available Product or related software or technology for any military purposes, including without limitation, for the design, development, use, stockpiling or manufacturing of nuclear, chemical, or biological weapons or missile technology products (mass destruction weapons). Product and related software and technology may be controlled under the applicable export laws and regulations including, without limitation, the Japanese Foreign Exchange and Foreign Trade Law and the U.S. Export Administration Regulations. Export and re-export of Product or related software or technology are strictly prohibited except in compliance with all applicable export laws and regulations.
- Please contact your TOSHIBA sales representative for details as to environmental matters such as the RoHS compatibility of Product. Please use Product in compliance with all applicable laws and regulations that regulate the inclusion or use of controlled substances, including without limitation, the EU RoHS Directive. **TOSHIBA ASSUMES NO LIABILITY FOR DAMAGES OR LOSSES OCCURRING AS A RESULT OF NONCOMPLIANCE WITH APPLICABLE LAWS AND REGULATIONS.**