

TOSHIBA Bi-CMOS Integrated Circuit Silicon Monolithic

TB6556FG

3-Phase Full-Wave Sine-Wave PWM Brushless Motor Controller

The TB6556FG is designed for motor fan applications for three-phase brushless DC (BLDC) motors.

Features

- Sine-wave PWM control
- Built-in triangular-wave generator
(Carrier cycle = $f_{OSC}/252$ (Hz))
- Built-in lead angle control function (0° to 58° in 32 steps)
External setting/automatic internal setting
- Built-in dead time function (setting $1.9 \mu\text{s}$ or $3.8 \mu\text{s}$)
- Overcurrent protection signal input pin
- Built-in regulator ($V_{refout} = 5 \text{ V}$ (typ.), 30 mA (max))
- Operating supply voltage range: $V_{CC} = 6 \text{ V}$ to 10 V

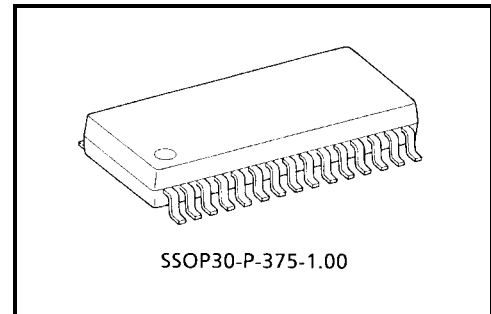

Weight: 0.63 g (typ.)

Block Diagram

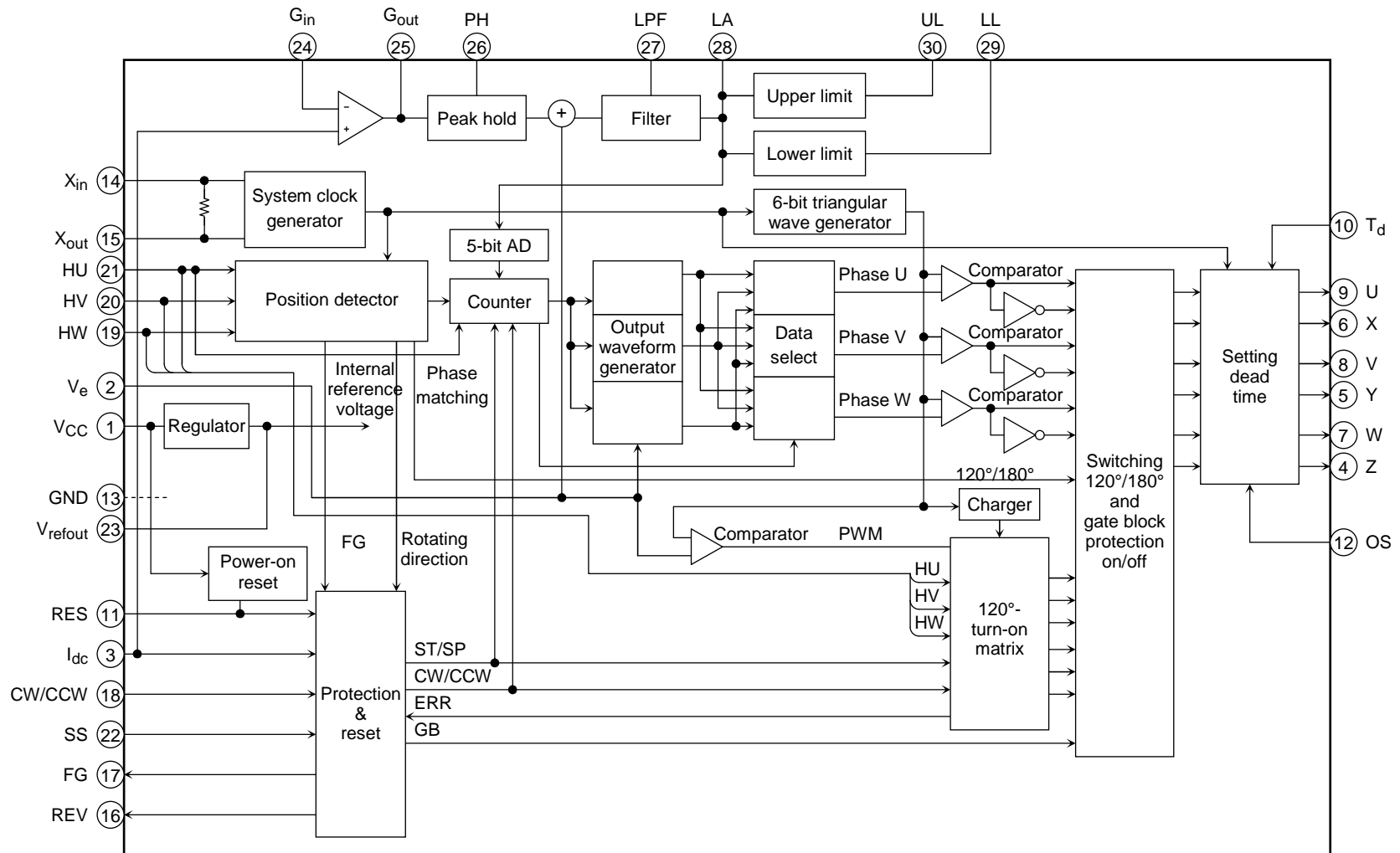

Some of the functional blocks, circuits, or constants in the block diagram may be omitted or simplified for explanatory purposes.

Pin Description

Pin No.	Symbol	Description	Remarks
21	HU	Positional signal input pin U	When positional signal is HHH or LLL, gate block protection operates. With built-in pull-up resistor, built-in digital filter (≈ 500 ns)
20	HV	Positional signal input pin V	
19	HW	Positional signal input pin W	
18	CW/CCW	Rotation direction signal input pin	L: Forward H: Reverse
11	RES	Reset-signal-input pin	L: Reset (output is non-active) operation/halt operation, also used for gate protection, built-in pull-up resistor
2	V _e	Voltage command signal	With built-in pull-down resistor
24	G _{in}	Gain setting	I _{dc} signal level at a gain that optimizes the LA
25	G _{out}		
26	PH	Peak hold	Connect the peak-hold capacitor and discharge resistor to GND, parallel to each other
27	LPF	RC low-pass filter	Connect the low-pass filter capacitor (built-in 100 kΩ resistor)
28	LA	Lead angle setting signal input pin	Sets 0° to 58° in 32 steps
29	LL	Lower limit for LA	Set lower limit for LA (LL = 0 V to 5.0 V)
30	UL	Upper limit for LA	Set upper limit for LA (UL = 0 V to 5.0 V)
12	OS	Inputs output logic select signal	L: Active LOW H: Active HIGH
3	I _{dc}	Inputs overcurrent protection signal	Inputs DC link current. Reference voltage: 0.5 V With built-in filter (≈ 1 μs), built-in digital filter (≈ 1 μs)
14	X _{in}	Inputs clock signal	With built-in feedback resistor
15	X _{out}	Outputs clock signal	
23	V _{refout}	Outputs reference voltage signal	5 V (typ.), 30 mA (max)
17	FG	FG signal output pin	Outputs 3 PPR of positional signal
16	REV	Reverse rotation detection signal	Detects reverse rotation.
9	U	Outputs turn-on signal	Select active HIGH or active LOW using the output logic select pin.
8	V	Outputs turn-on signal	
7	W	Outputs turn-on signal	
6	X	Outputs turn-on signal	
5	Y	Outputs turn-on signal	
4	Z	Outputs turn-on signal	
1	V _{CC}	Power supply voltage pin	V _{CC} = 6 to 10 V
10	T _d	Inputs setting dead time	L: 3.8 μs, H or OPEN: 1.9 μs
22	SS	120°/180° select signal	L: 120° turn-on mode, H or OPEN: 180° turn-on mode
13	GND	Ground pin	—

Input/Output Equivalent Circuits

Pin Description	Symbol	Input/Output Signal	Input/Output Internal Circuit
Positional signal input pin U Positional signal input pin V Positional signal input pin W	HU HV HW	Digital With Schmitt trigger Hysteresis 300 mV (typ.) Digital filter: 500 ns (typ.) L: 0.8 V (max) H: $V_{\text{refout}} - 1 \text{ V}$ (min)	
Forward/reverse switching input pin L: Forward (CW) H: Reverse (CCW)	CW/CCW	Digital L: 0.8 V (max) H: $V_{\text{refout}} - 1 \text{ V}$ (min)	
Reset input L: Stops operation (reset) H: Operates	RES	Digital L: 0.8 V (max) H: $V_{\text{refout}} - 1 \text{ V}$ (min)	
120°/180° select signal L: 120° turn-on mode H: 180° turn-on mode (OPEN)	SS	Digital With Schmitt trigger Hysteresis: 300 mV (typ.) L: 0.8 V (max) H: $V_{\text{refout}} - 1 \text{ V}$ (min)	
Voltage command signal 1.0 V < V_e ≤ 2.1 V Refresh operation (X, Y, Z pins: ON duty of 8%)	V_e	Analog Input voltage range 0 to 5.4 V Input voltage of 5.4 V or higher is clipped to 5.4 V.	

Pin Description	Symbol	Input/Output Signal	Input/Output Internal Circuit
<p>Lead angle setting signal input pin</p> <p>0 V: 0° 5 V: 58° (5-bit AD)</p>	LA	<p>When LA is fixed externally, connect LL to GND and UL to V_{refout}, and then input the setting voltage to the LA pin.</p> <p>Input voltage range: 0 V to 5.0 V (V_{refout})</p> <p>Input voltage of V_{refout} or higher is clipped to V_{refout}.</p> <p>When LA is fixed automatically, open the LA pin. In this state, the LA pin is used only for confirmation of LA width.</p>	
<p>Gain setting signal input (LA setting)</p>	<p>G_{in} G_{out}</p>	<p>Non-inverted amplifier 25 dB (max)</p> <p>G_{out} output voltage LOW: GND HIGH: $V_{CC} - 1.7$ V</p>	
<p>Peak hold (LA setting)</p>	PH	<p>Connect the peak-hold capacitor and discharge resistor to GND, parallel to each other. 100 kΩ/0.1μF recommended</p>	
<p>Low-pass filter (LA setting)</p>	LPF	<p>Connect the low-pass filter capacitor Built-in 100 kΩ (typ.) resistor 0.1μF recommended</p>	
<p>Lower limit for LA</p>	LL	<p>Clip lower limit for LA LL = 0 V to 5.0 V When LL > UL, LA is fixed at LL value.</p>	

Pin Description	Symbol	Input/Output Signal	Input/Output Internal Circuit
Upper limit for LA	UL	Clip upper limit for LA UL = 0 V to 5.0 V When LL > UL, LA is fixed at LL value.	
Setting dead time input pin L: 3.8 μs H or OPEN: 1.9 μs	T _d	Digital L: 0.8 V (max) H: V _{refout} - 1 V (min)	
Output logic select signal input pin L: Active LOW H: Active HIGH	OS	Digital L: 0.8 V (max) H: V _{refout} - 1 V (min)	
Overcurrent protection signal input pin	I _{dc}	Analog Digital filter: 1 μs (typ.) Gate protected at 0.5 V or higher (released at carrier cycle)	
Clock signal input pin	X _{in}	Operating range 2 MHz to 8 MHz (ceramic oscillation)	
Clock signal output pin	X _{out}		

Pin Description	Symbol	Input/Output Signal	Input/Output Internal Circuit
Reference voltage signal output pin	V_{refout}	$5 \pm 0.5 \text{ V}$ (max 30 mA)	
Reverse-rotation-detection signal output pin	REV	Digital Push-pull output: $\pm 1 \text{ mA}$ (max)	
FG signal output pin	FG	Digital Push-pull output: $\pm 1 \text{ mA}$ (max)	
Turn-on signal output pin U Turn-on signal output pin V Turn-on signal output pin W Turn-on signal output pin X Turn-on signal output pin Y Turn-on signal output pin Z	U V W X Y Z	Analog Push-pull output: $\pm 2 \text{ mA}$ (max) L: 0.78 V (max) H: $V_{refout} - 0.78 \text{ V}$ (min)	

Absolute Maximum Ratings ($T_a = 25^\circ\text{C}$)

Characteristics	Symbol	Rating	Unit
Supply voltage	V_{CC}	12	V
Input voltage	$V_{in(1)}$	-0.3 to V_{CC} (Note 1)	V
	$V_{in(2)}$	-0.3 to $V_{refout} + 0.3$ (Note 2)	
Turn-on signal output current	I_{OUT}	2	mA
Power dissipation	P_D	1.50 (Note 3)	W
Operating temperature	T_{opr}	-30 to 115 (Note 4)	$^\circ\text{C}$
Storage temperature	T_{stg}	-50 to 150	$^\circ\text{C}$

Note 1: $V_{in(1)}$ pin: V_e , LA, G_{in} , G_{out} , PH, LPF, LL, UL

Note 2: $V_{in(2)}$ pin: HU, HV, HW, CW/CCW, RES, OS, I_{dc} , T_d , SS

Note 3: When mounted on PCB (universal 50 mm × 50 mm × 1.6 mm, Cu 30%)

Note 4: Operating temperature range is determined by the $P_D - T_a$ characteristic.

Operating Conditions ($T_a = 25^\circ\text{C}$)

Characteristics	Symbol	Min	Typ.	Max	Unit
Supply voltage	V_{CC}	6	7	10	V
Ceramic oscillation frequency	X_{in}	2	4	8	MHz

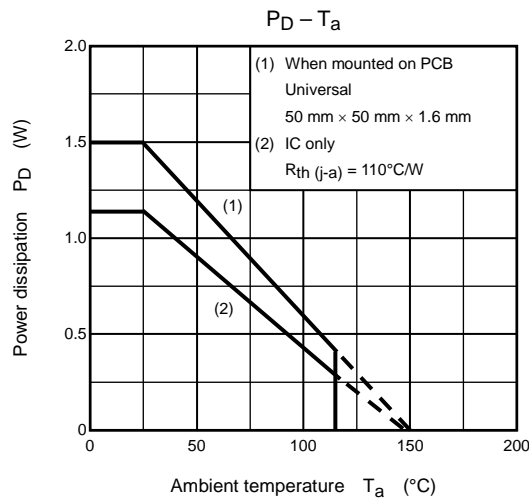

Electrical Characteristics (T_a = 25°C, V_{CC} = 7 V)

Characteristics	Symbol	Test Circuit	Test Condition	Min	Typ.	Max	Unit	
Supply current	I _{CC}	—	V _{refout} = open	—	5	8	mA	
Input current	I _{in} (1)-1	—	V _{in} = 5 V LA	—	25	50	μA	
	I _{in} (1)-2		V _{in} = 5 V V _e	—	35	70		
	I _{in} (2)-1		V _{in} = 0 V HU, HV, HW, SS	-50	-25	—		
	I _{in} (2)-2		V _{in} = 0 V CW/CCW, OS, T _d , RES	-100	-50	—		
Input voltage	V _{in}	HIGH	HU, HV, HW, CW/CCW, RES, OS, T _d , SS	V _{refout} - 1	—	V _{refout}	V	
		LOW		—	—	0.8		
	V _e	H	—	Modulation factor maximum	5.1	5.4	5.7	V
		M		Refresh → Start motor operation	1.8	2.1	2.4	
L		Turned-off → Refresh		0.7	1.0	1.3		
Input hysteresis voltage	V _H	—	HU, HV, HW, SS (Note 5)	—	0.3	—	V	
Input delay time	V _{DT}	—	HU, HV, HW X _{in} = 4.19 MHz	—	0.5	—	μs	
	V _{DC}		I _{dc} X _{in} = 4.19 MHz	—	1.0	—		
Output voltage	V _{OUT} (H)-1	—	I _{OUT} = 2 mA U, V, W, X, Y, Z	V _{refout} - 0.78	V _{refout} - 0.3	—	V	
	V _{OUT} (L)-1		I _{OUT} = -2 mA U, V, W, X, Y, Z	—	0.3	0.78		
	V _{REV} (H)		I _{OUT} = 1 mA REV	V _{refout} - 1.0	V _{refout} - 0.2	—		
	V _{REV} (L)		I _{OUT} = -1 mA REV	—	0.2	1.0		
	V _{FG} (H)		I _{OUT} = 1 mA FG	V _{refout} - 1.0	V _{refout} - 0.2	—		
	V _{FG} (L)		I _{OUT} = -1 mA FG	—	0.2	1.0		
	V _{refout}		I _{OUT} = 30 mA V _{refout}	4.5	5.0	5.5		
Output leakage current	I _L (H)	—	V _{OUT} = 0 V U, V, W, X, Y, Z	—	0	10	μA	
	I _L (L)		V _{OUT} = 3.5 V U, V, W, X, Y, Z	—	0	10		
Output off-time by upper/lower transistor (Note 6)	T _{OFF} (H)	—	T _d = HIGH or OPEN, X _{in} = 4.19 MHz, I _{OUT} = ± 2 mA, OS = HIGH/LOW	1.5	1.9	—	μs	
	T _{OFF} (L)		T _d = LOW, X _{in} = 4.19 MHz, I _{OUT} = ± 2 mA, OS = HIGH/LOW	3.0	3.8	—		
Overcurrent detection	V _{dc}	—	I _{dc}	0.46	0.5	0.54	V	
LA gain setting amp	AMP _{OUT}	—	G _{OUT} output current	5	—	—	mA	
	AMP _{OFS}		G _{IN} , G _{OUT} 11 kΩ/1 kΩ	—	-40	—		
LA limit setting difference	ΔL	—	LL = 0.7 V	-20	—	20	mV	
	ΔU		UL = 2.0 V	-20	—	20		
LA peak hold output current	PH _{OUT}	—	PH output current	—	—	5	mA	
Lead angle correction	T _{LA} (0)	—	LA = 0 V or OPEN, Hall IN = 100 Hz	—	0	—	°	
	T _{LA} (2.5)		LA = 2.5 V, Hall IN = 100 Hz	27.5	32	34.5		
	T _{LA} (5)		LA = 5 V, Hall IN = 100 Hz	53.5	59	62.5		
V _{CC} monitor	V _{CC} (H)	—	Output start operation point	4.2	4.5	4.8	V	
	V _{CC} (L)		No output operation point	3.7	4.0	4.3		
	V _H		Input hysteresis width	—	0.5	—		

Note 5: Toshiba does not implement testing before shipping.

Note 6: T_{OFF}

OS = HIGH

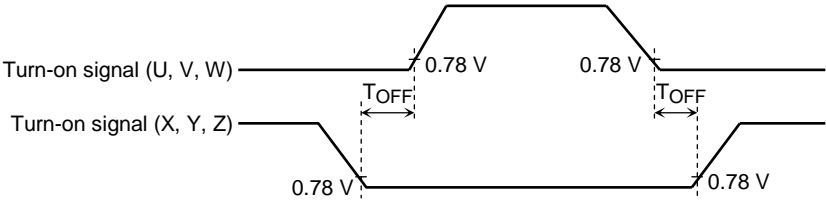

OS = LOW

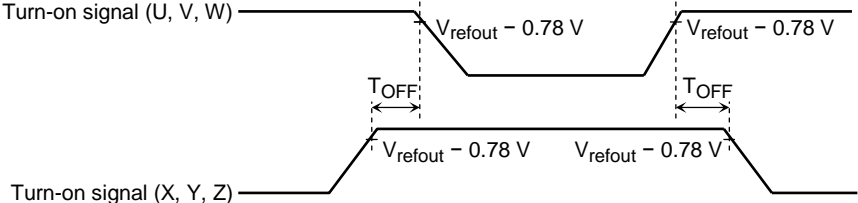

Functional Description

1. Basic operation

The motor is driven by the square-wave turn-on signal based on a positional signal. When the positional signal reaches frequency $f = 5$ Hz or higher, the rotor position is estimated according to the positional signal and a modulation wave is generated. The modulation wave and the triangular wave are compared; then the sine-wave PWM signal is generated and the motor is driven.

From start to 5 Hz: When driven by square wave (120° turn-on) $f = f_{OSC} / (2^{12} \times 32 \times 6)$

5 Hz or higher: When driven by sine-wave PWM (180° turn-on); when $f_{OSC} = 4$ MHz, approx. 5 Hz

2. Select drive function

This function can select drive mode.

SS pin

HIGH or OPEN = Sine-wave PWM drive (180° turn-on mode)

LOW = Square-wave drive (120° turn-on mode)

Note: If the position sensing signal is $f = 5$ Hz or lower, the driver is 120° turn-on mode even when SS = HIGH.

3. V_e voltage command signal function and function to stabilize bootstrap voltage

(1) When the voltage command signal is input at $V_e \leq 1.0$ V:

Turns off output (gate protection)

(2) When the voltage command signal is input at 1.0 V $< V_e \leq 2.1$ V:

Turns on the lower transistor at the regular (carrier) cycle. (ON duty is approx. 8%.)

(3) When the voltage command signal is input at $V_e > 2.1$ V:

During sin-wave drive, outputs drive signal as it is. During square-drive, forcibly turns on the lower transistor at regular (carrier) cycle. (ON duty is approx. 8%)

Note: At startup, turn the lower transistor on for a fixed time with 1.0 V $< V_e \leq 2.1$ V to charge the upper transistor gate power supply.

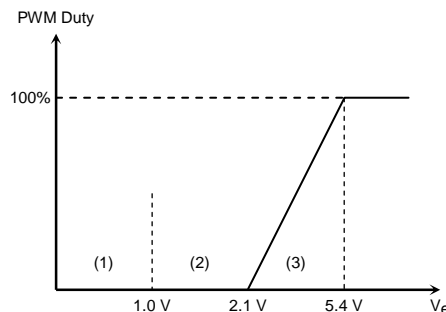

4. Dead time function: upper/lower transistor output off-time

When the motor is driven by sine-wave PWM, dead time is digitally generated in the IC to prevent a short circuit caused by the simultaneous turning on of upper and lower external power devices. When a square wave is generated in full-duty cycle mode, the dead time function is turned on to prevent a short circuit.

T_d Pin	Internal Counter	T_{OFF}
HIGH or OPEN	$8/f_{OSC}$	1.9 μ s
LOW	$16/f_{OSC}$	3.8 μ s

T_{OFF} values above are obtained when $f_{OSC} = 4.19$ MHz.

f_{OSC} = reference clock (ceramic oscillation)

5. Correcting the lead angle

The lead angle can be corrected in the turn-on signal range from 0 to 58° in relation to the induced voltage.

Analog input from LA pin (0 V to 5 V divided by 32):

0 V = 0°

5 V = 58° (when more than 5 V is input, 58°)

6. Setting the carrier frequency

This function sets the triangular wave cycle (carrier cycle) necessary for generating the PWM signal. (The triangular wave is used for forcibly turning on the lower transistor when the motor is driven by square wave.)

Carrier cycle = fOSC/252 (Hz) fOSC = reference clock (ceramic oscillation)

7. Switching the output of the turn-on signal

This function switches the output of the turn-on signal between HIGH and LOW.

Pin OS:

HIGH = active HIGH

LOW = active LOW

8. Outputting the reverse rotation detection signal

This function detects the motor rotation direction every electrical angle of 360°. (The output is HIGH immediately after reset.)

When the signal of REV terminal is low, the operation transfers to 180° commutation mode. (Hall IN = 5 Hz or more)

CW/CCW Pin	Actual Motor Rotating Direction	REV Pin
LOW (CW)	CW (forward)	LOW
	CCW (reverse)	HIGH
HIGH (CCW)	CW (forward)	HIGH
	CCW (reverse)	LOW

9. Protecting input pin

1. Overcurrent protection (Pin I_{dc})

When the DC-link-voltage which is converted from DC-link-current exceeds the internal reference voltage, performs gate block protection. Overcurrent protection is released for each carrier frequency.

Reference voltage = 0.5 V (typ.)

2. Gate protection (Pin RES)

Output is turned off when the input signal is LOW, restarted when the input signal is HIGH. The abnormality is detected externally and the signal input to pin RES.

RES Pin	OS Pin	Output Turn-on Signal (U, V, W, X, Y, Z)
LOW	LOW	HIGH
	HIGH	LOW

(When RES = LOW, bootstrap capacitor charging stops.)

3. Internal protection

- Positional signal abnormality protection

Output is turned off when the positional signal is HHH or LLL; otherwise, it is restarted.

- Low power supply voltage protection (VCC monitor)

For power supply on/off outside the operating voltage range, the turn-on signal output is kept at high impedance outside the operating voltage range to prevent damage caused by power device short circuits.

However, if the voltage level is supplied from the V_e pin, this function is restricted, e.g., when $V_e > 4.9\text{ V}$ is applied, low power supply voltage protection does not operate.

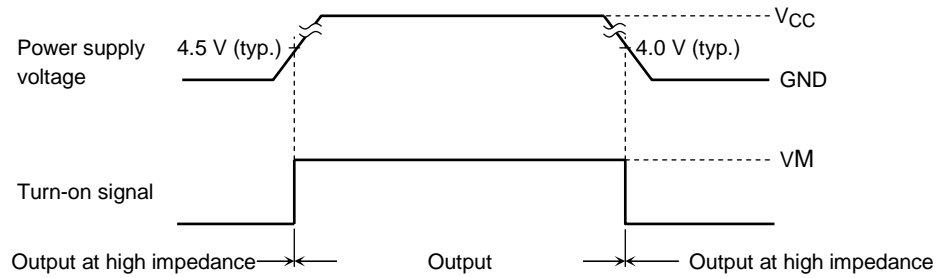

Operation Flow

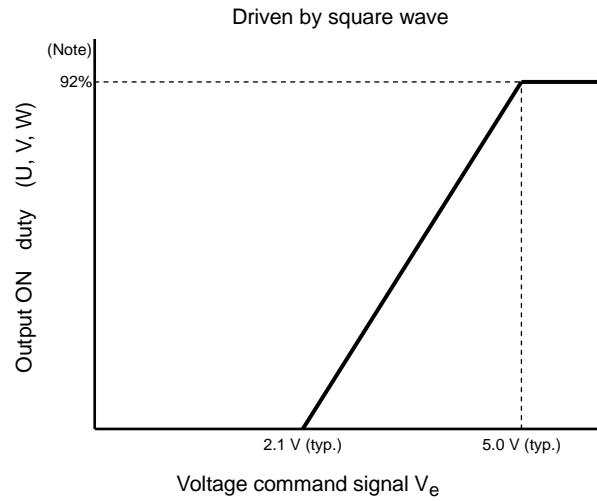
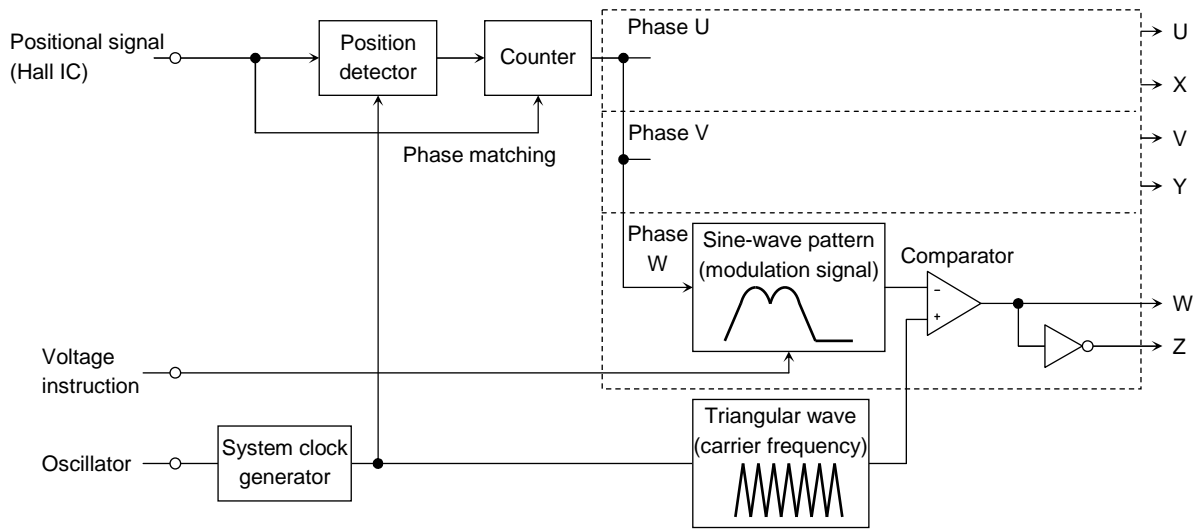

Note: Output ON time is decreased by the dead time
 $(\text{carrier cycle} \times 92\% - T_d \times 2)$

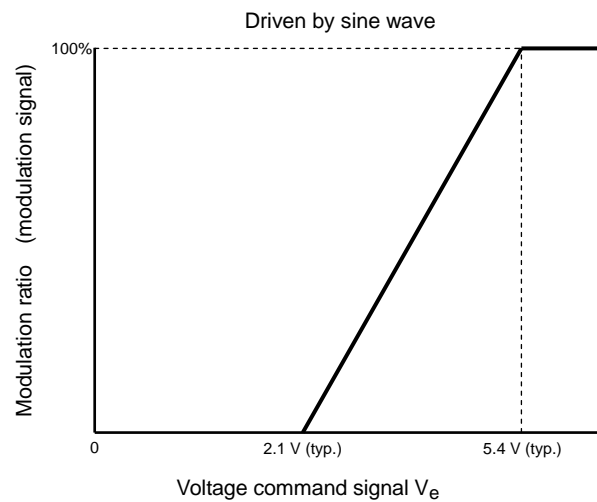

The modulation waveform is generated using Hall signals. The modulation waveform is then compared with the triangular wave and a sine-wave PWM signal is generated.

The time (electrical degrees: 60°) from the rising (or falling) edges of the three Hall signals to the next falling (or rising) edges is counted. The counted time is used as the data for the next 60° phase of the modulation waveform.

There are 32 items of data for the 60° phase of the modulation waveform. The time width of one data item is 1/32 of the time width of the 60° phase of the previous modulation waveform. The modulation waveform moves forward by the width.

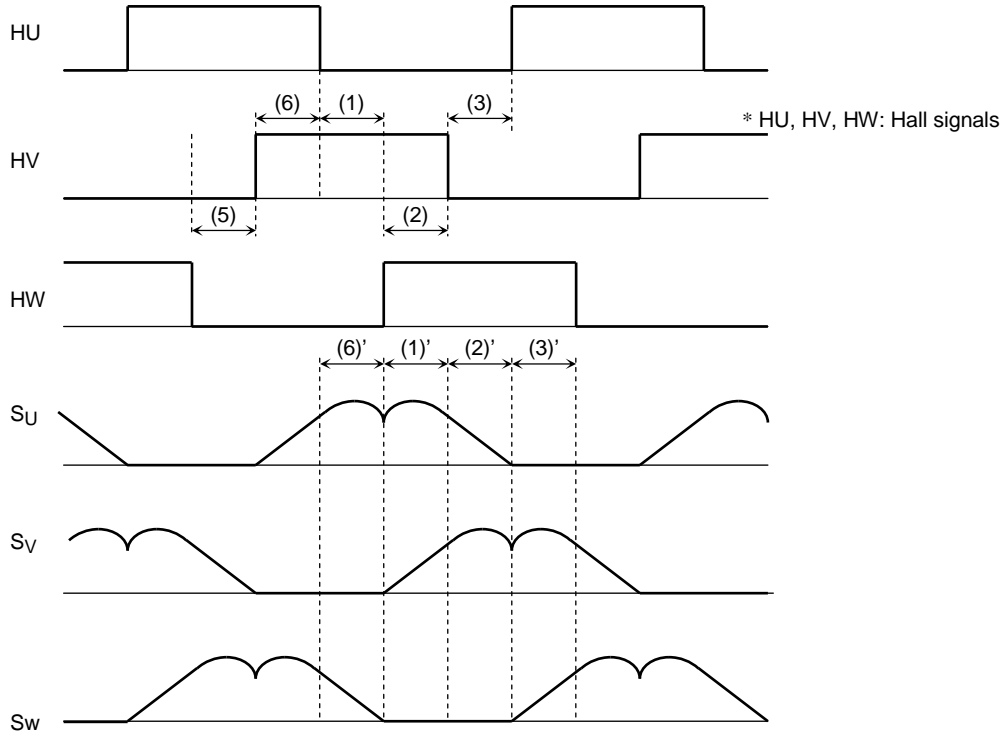

In the above diagram, the modulation waveform (1)' data moves forward by the 1/32 time width of the time (1) from HU: ↑ to HW: ↓. Similarly, data (2)' moves forward by the 1/32 time width of the time (2) from HW: ↓ to HV: ↑.

If the next edge does not occur after the 32 data items end, the next 32 data items move forward by the same time width until the next edge occurs.

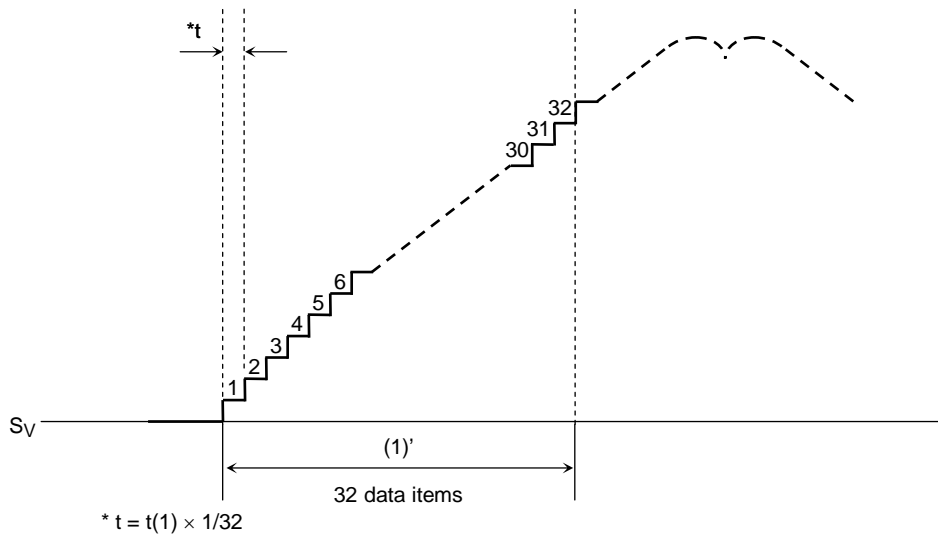

The modulation wave is brought into phase with every zero-cross point of the Hall signal.

The modulation wave is reset in synchronization with the rising and falling edges of the Hall signal at every 60° electrical angle. Thus, when the Hall device is not placed at the correct position or during acceleration and deceleration, the modulation waveform is not continuous at every reset.

Timing Charts

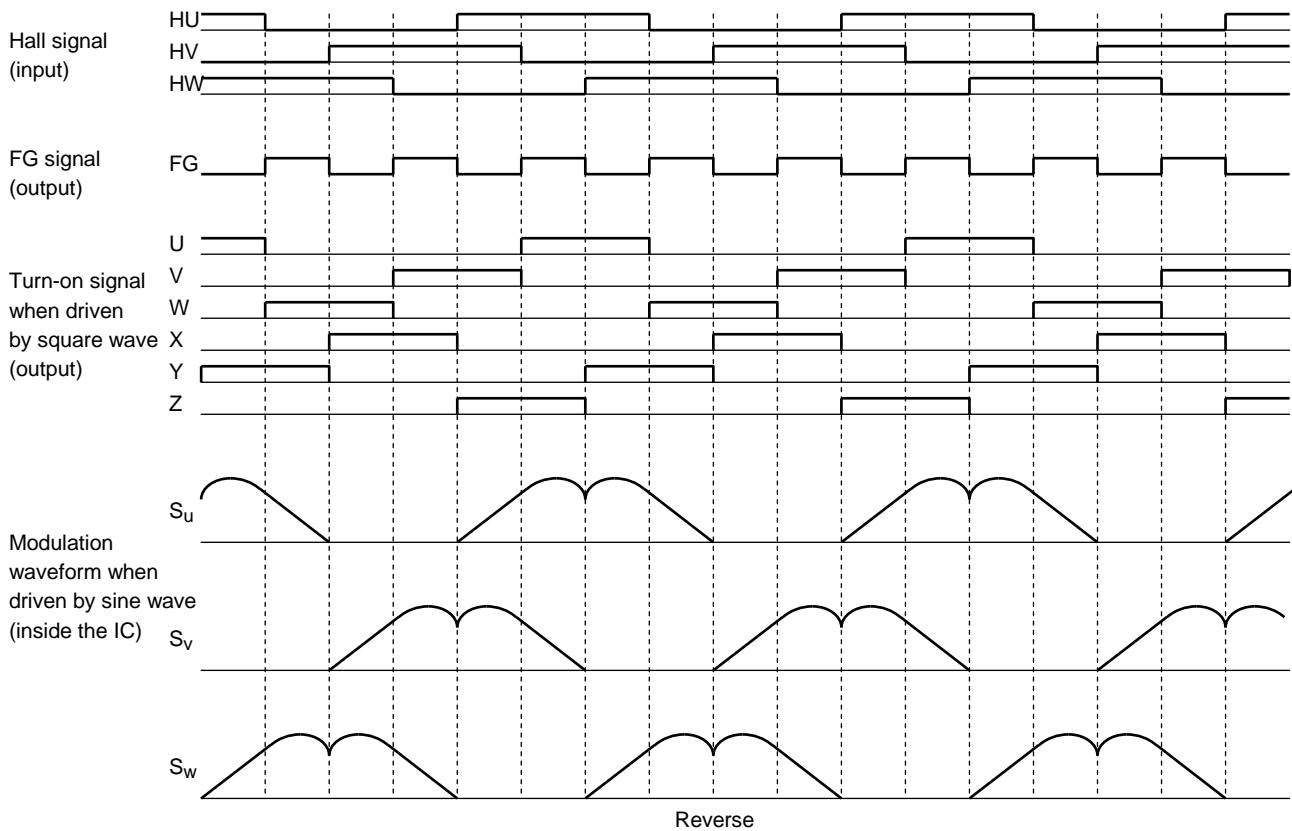
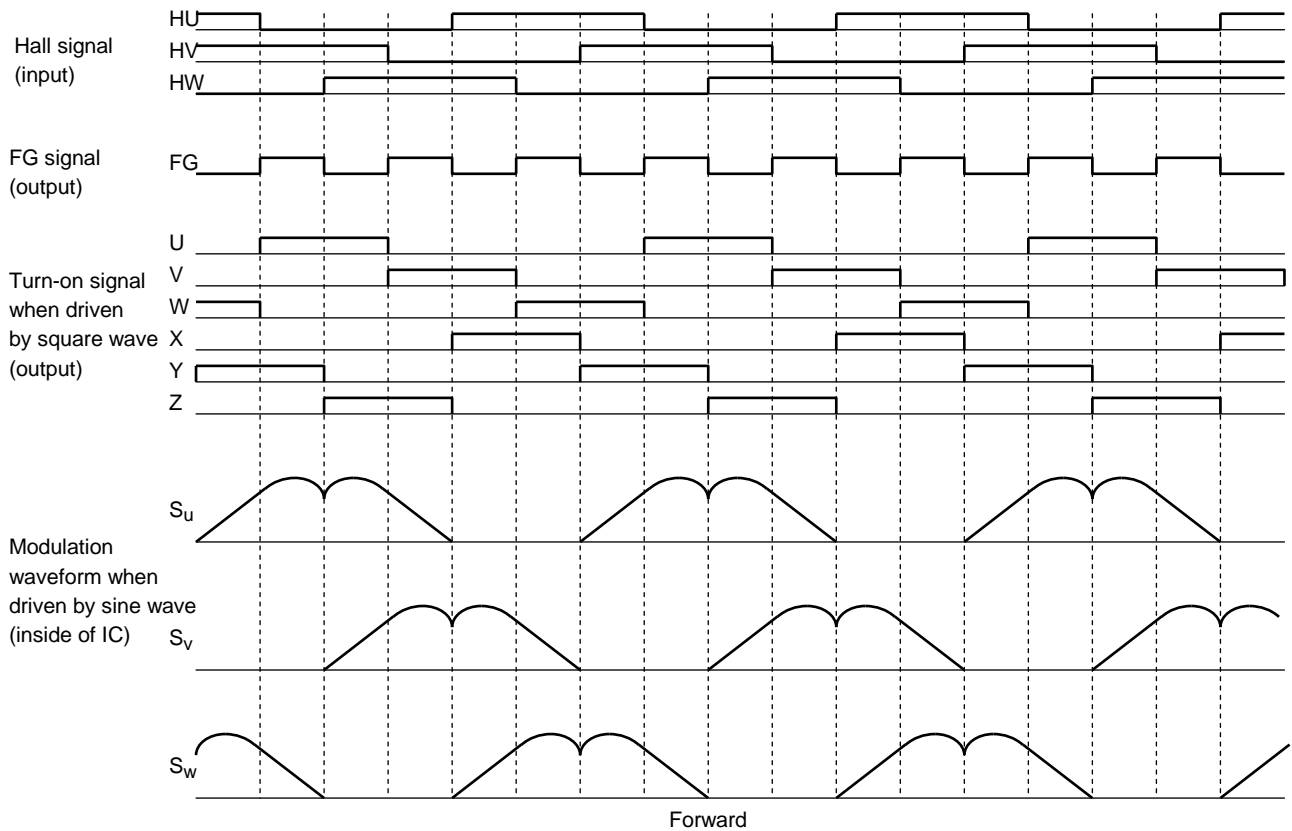

Timing charts may be simplified for explanatory purposes.

Operating Waveform When Driven by Square Wave (CW/CCW = LOW, OS = HIGH, SS = High)

Hall signal

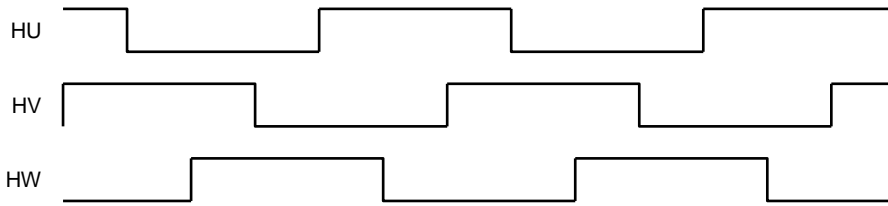

Output waveform

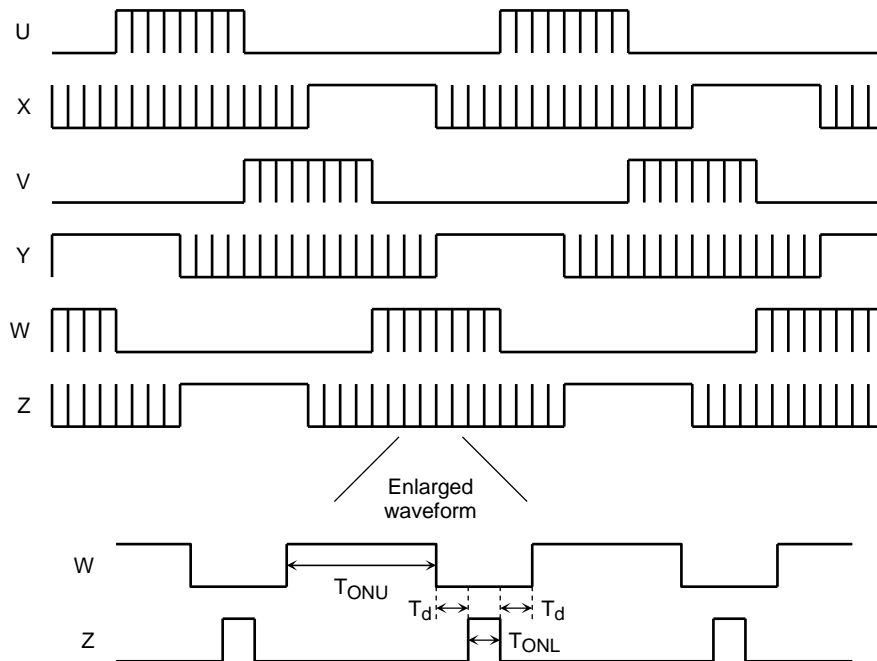

To stabilize the bootstrap voltage, the lower outputs (X, Y, and Z) are always turned on at the carrier cycle even during off time. At that time, the upper outputs (U, V, and W) are assigned dead time and turned off at the timing when the lower outputs are turned on. (T_d varies with input V_e .)

$$\text{Carrier cycle} = f_{OSC}/252 \text{ (Hz)}$$

$$\text{Dead time: } T_d = 16/f_{OSC} \text{ (s) (In more than } V_e = 5.0 \text{ V when } T_d = \text{Low.)}$$

$$T_{ONL} = \text{carrier cycle} \times 8\% \text{ (s) (Uniformity)}$$

When the motor is driven by a square wave, acceleration or deceleration is determined by voltage V_e . The motor accelerates or decelerates according to the ON duty of T_{ONU} . (See the diagram of output ON duty on page 14.)

Note: The motor is driven by a square wave when the Hall signals are 5 Hz or lower ($f_{OSC} = 4 \text{ MHz}$) and the motor is rotating in the reverse direction to that of the TB6556FG controlling it (REV = HIGH).

Operating Waveform When Driven by Sine-Wave PWM (CW/CCW = LOW, OS = HIGH, SS = High)

Generation inside of IC

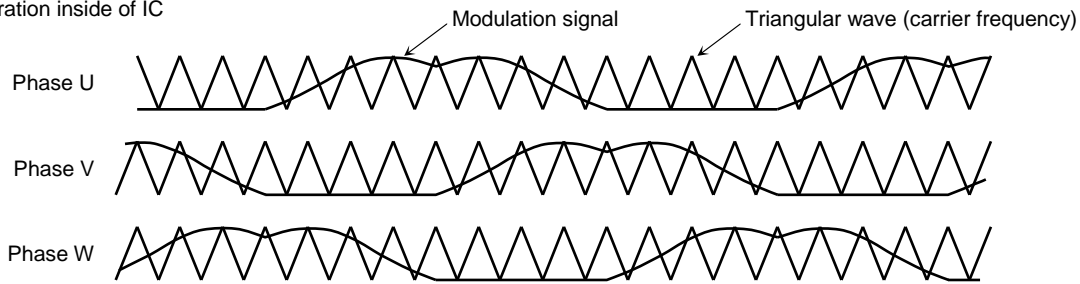

Output waveform

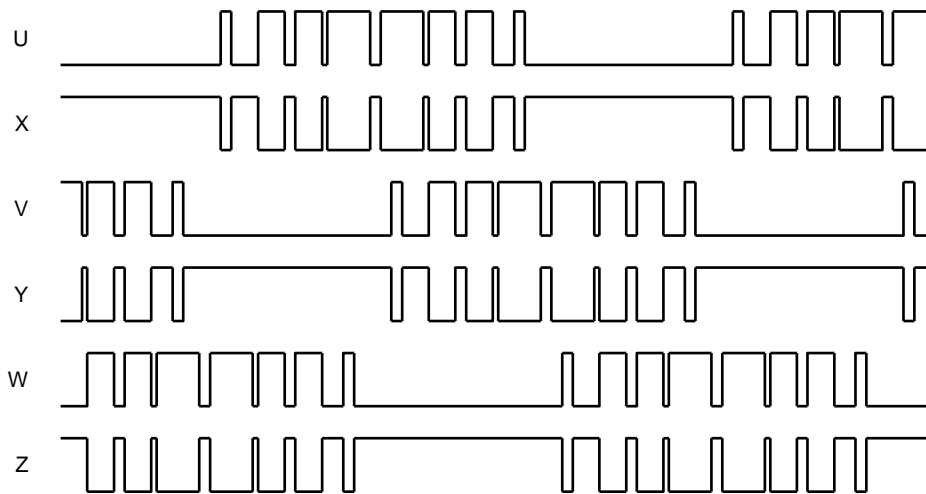

Inter-line voltage

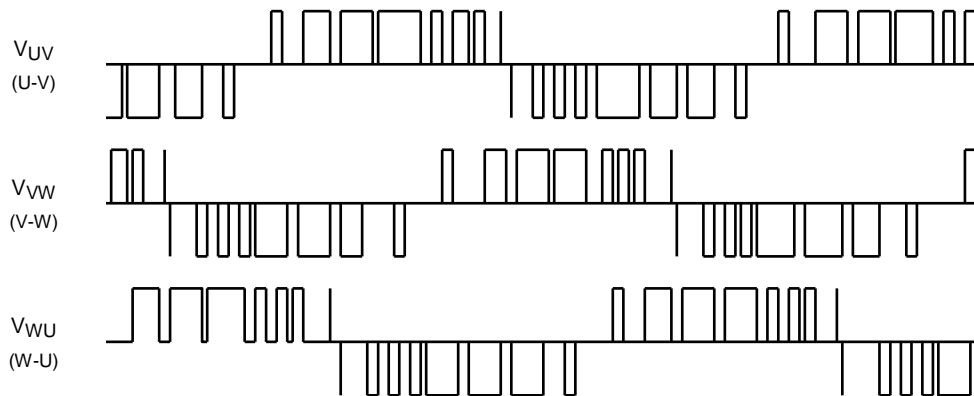

When driven by a sine wave, the motor is accelerated or decelerated according to the ON duty of TONU as the amplitude of the modulation symbol changes according to voltage V_e . (See the diagram of the modulation ratio on page 14.)

$$\text{Triangular wave frequency} = \text{carrier frequency} = f_{\text{OSC}}/252 \text{ (Hz)}$$

Note: At startup, the motor is driven by a sine wave when the Hall signals are 5 Hz or higher ($f_{\text{OSC}} = 4 \text{ MHz}$) and the motor is rotating in the same direction as the TB6556FG controlling it (REV = LOW).

Example of Application Circuit

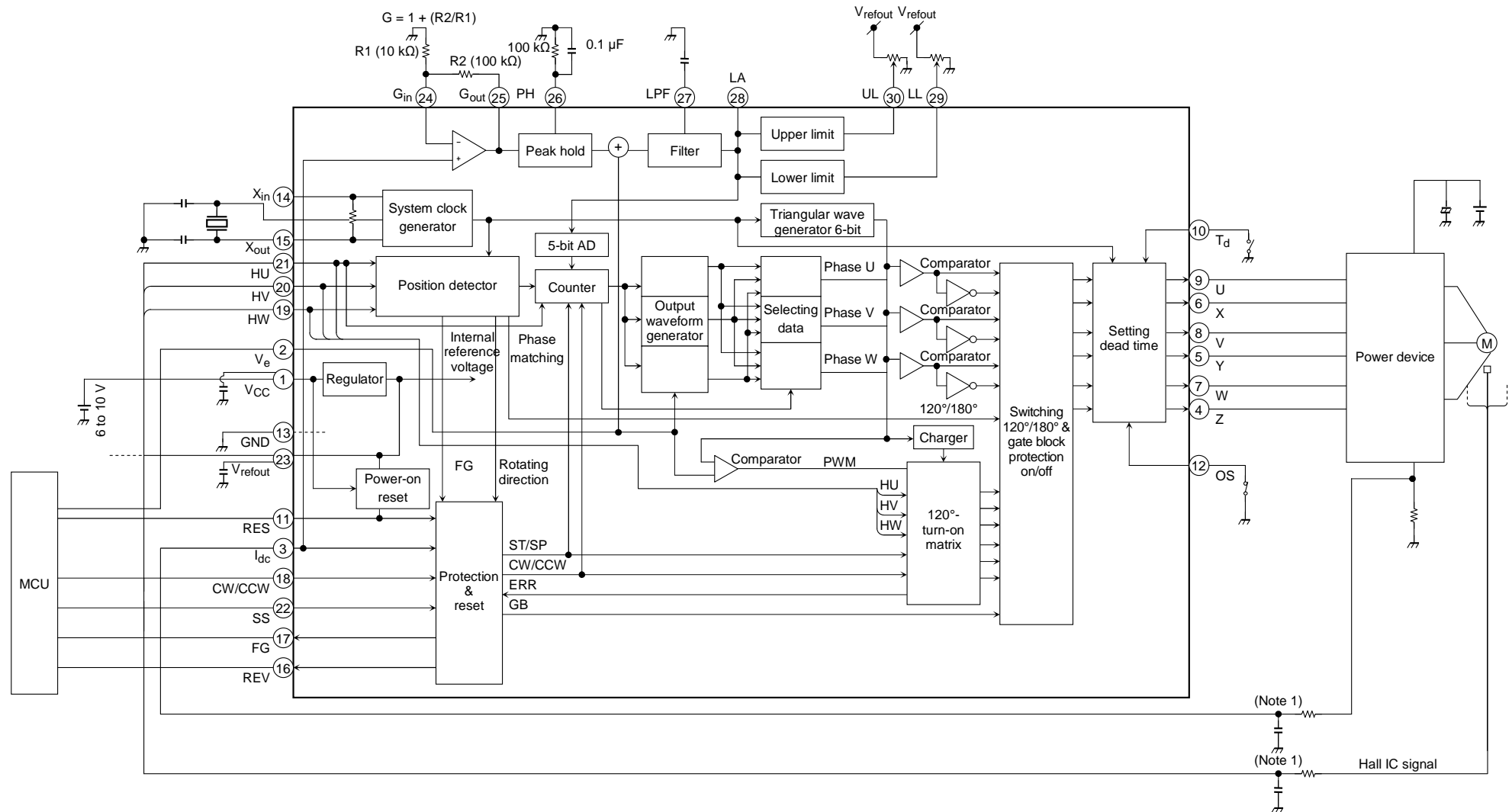

Note 1: Connect to ground as necessary to prevent IC malfunction due to noise.

Note 2: Connect GND to signal ground on the application circuit.

Note 3: Utmost care is necessary in the design of the output, V_{CC}, and GND lines since the IC may be destroyed by short-circuiting between outputs, air contamination faults, or faults due to improper grounding, or by short-circuiting between contiguous pins.

Package Dimensions

SSOP30-P-375-1.00

Unit : mm

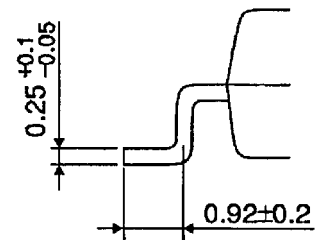
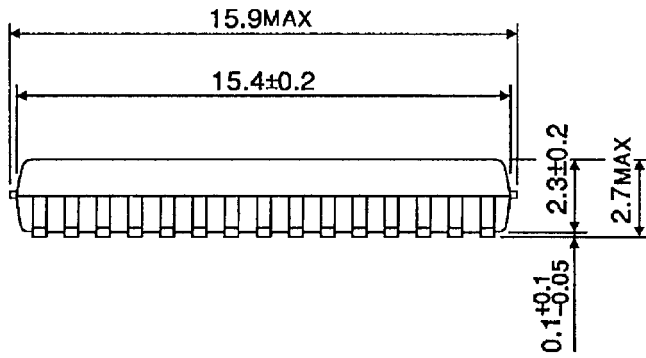
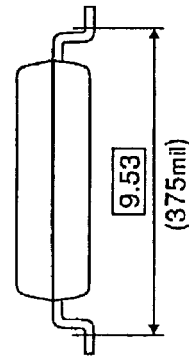
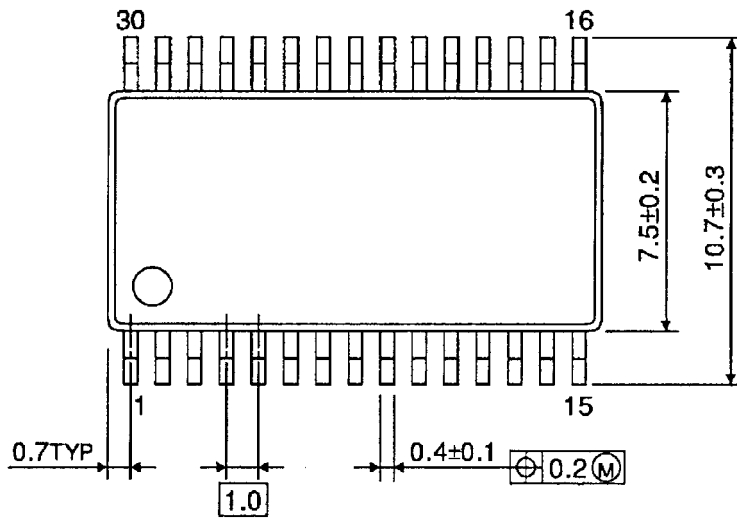

Weight: 0.63 g (typ.)

Notes on Contents

1. Block Diagrams

Some of the functional blocks, circuits, or constants in the block diagram may be omitted or simplified for explanatory purposes.

2. Equivalent Circuits

The equivalent circuit diagrams may be simplified or some parts of them may be omitted for explanatory purposes.

3. Timing Charts

Timing charts may be simplified for explanatory purposes.

4. Application Circuits

The application circuits shown in this document are provided for reference purposes only. Thorough evaluation is required, especially at the mass production design stage.

Toshiba does not grant any license to any industrial property rights by providing these examples of application circuits.

5. Test Circuits

Components in the test circuits are used only to obtain and confirm the device characteristics. These components and circuits are not guaranteed to prevent malfunction or failure from occurring in the application equipment.

IC Usage Considerations

Notes on handling of ICs

- [1] The absolute maximum ratings of a semiconductor device are a set of ratings that must not be exceeded, even for a moment. Do not exceed any of these ratings.
Exceeding the rating(s) may cause the device breakdown, damage or deterioration, and may result injury by explosion or combustion.
- [2] Do not insert devices in the wrong orientation or incorrectly.
Make sure that the positive and negative terminals of power supplies are connected properly.
Otherwise, the current or power consumption may exceed the absolute maximum rating, and exceeding the rating(s) may cause the device breakdown, damage or deterioration, and may result injury by explosion or combustion.
In addition, do not use any device that is applied the current with inserting in the wrong orientation or incorrectly even just one time.

RESTRICTIONS ON PRODUCT USE

- Toshiba Corporation, and its subsidiaries and affiliates (collectively "TOSHIBA"), reserve the right to make changes to the information in this document, and related hardware, software and systems (collectively "Product") without notice.
- This document and any information herein may not be reproduced without prior written permission from TOSHIBA. Even with TOSHIBA's written permission, reproduction is permissible only if reproduction is without alteration/omission.
- Though TOSHIBA works continually to improve Product's quality and reliability, Product can malfunction or fail. Customers are responsible for complying with safety standards and for providing adequate designs and safeguards for their hardware, software and systems which minimize risk and avoid situations in which a malfunction or failure of Product could cause loss of human life, bodily injury or damage to property, including data loss or corruption. Before customers use the Product, create designs including the Product, or incorporate the Product into their own applications, customers must also refer to and comply with (a) the latest versions of all relevant TOSHIBA information, including without limitation, this document, the specifications, the data sheets and application notes for Product and the precautions and conditions set forth in the "TOSHIBA Semiconductor Reliability Handbook" and (b) the instructions for the application with which the Product will be used with or for. Customers are solely responsible for all aspects of their own product design or applications, including but not limited to (a) determining the appropriateness of the use of this Product in such design or applications; (b) evaluating and determining the applicability of any information contained in this document, or in charts, diagrams, programs, algorithms, sample application circuits, or any other referenced documents; and (c) validating all operating parameters for such designs and applications. **TOSHIBA ASSUMES NO LIABILITY FOR CUSTOMERS' PRODUCT DESIGN OR APPLICATIONS.**
- **PRODUCT IS NEITHER INTENDED NOR WARRANTED FOR USE IN EQUIPMENTS OR SYSTEMS THAT REQUIRE EXTRAORDINARILY HIGH LEVELS OF QUALITY AND/OR RELIABILITY, AND/OR A MALFUNCTION OR FAILURE OF WHICH MAY CAUSE LOSS OF HUMAN LIFE, BODILY INJURY, SERIOUS PROPERTY DAMAGE AND/OR SERIOUS PUBLIC IMPACT ("UNINTENDED USE").** Except for specific applications as expressly stated in this document, Unintended Use includes, without limitation, equipment used in nuclear facilities, equipment used in the aerospace industry, medical equipment, equipment used for automobiles, trains, ships and other transportation, traffic signaling equipment, equipment used to control combustions or explosions, safety devices, elevators and escalators, devices related to electric power, and equipment used in finance-related fields. **IF YOU USE PRODUCT FOR UNINTENDED USE, TOSHIBA ASSUMES NO LIABILITY FOR PRODUCT.** For details, please contact your TOSHIBA sales representative.
- Do not disassemble, analyze, reverse-engineer, alter, modify, translate or copy Product, whether in whole or in part.
- Product shall not be used for or incorporated into any products or systems whose manufacture, use, or sale is prohibited under any applicable laws or regulations.
- The information contained herein is presented only as guidance for Product use. No responsibility is assumed by TOSHIBA for any infringement of patents or any other intellectual property rights of third parties that may result from the use of Product. No license to any intellectual property right is granted by this document, whether express or implied, by estoppel or otherwise.
- **ABSENT A WRITTEN SIGNED AGREEMENT, EXCEPT AS PROVIDED IN THE RELEVANT TERMS AND CONDITIONS OF SALE FOR PRODUCT, AND TO THE MAXIMUM EXTENT ALLOWABLE BY LAW, TOSHIBA (1) ASSUMES NO LIABILITY WHATSOEVER, INCLUDING WITHOUT LIMITATION, INDIRECT, CONSEQUENTIAL, SPECIAL, OR INCIDENTAL DAMAGES OR LOSS, INCLUDING WITHOUT LIMITATION, LOSS OF PROFITS, LOSS OF OPPORTUNITIES, BUSINESS INTERRUPTION AND LOSS OF DATA, AND (2) DISCLAIMS ANY AND ALL EXPRESS OR IMPLIED WARRANTIES AND CONDITIONS RELATED TO SALE, USE OF PRODUCT, OR INFORMATION, INCLUDING WARRANTIES OR CONDITIONS OF MERCHANTABILITY, FITNESS FOR A PARTICULAR PURPOSE, ACCURACY OF INFORMATION, OR NONINFRINGEMENT.**
- Do not use or otherwise make available Product or related software or technology for any military purposes, including without limitation, for the design, development, use, stockpiling or manufacturing of nuclear, chemical, or biological weapons or missile technology products (mass destruction weapons). Product and related software and technology may be controlled under the applicable export laws and regulations including, without limitation, the Japanese Foreign Exchange and Foreign Trade Law and the U.S. Export Administration Regulations. Export and re-export of Product or related software or technology are strictly prohibited except in compliance with all applicable export laws and regulations.
- Please contact your TOSHIBA sales representative for details as to environmental matters such as the RoHS compatibility of Product. Please use Product in compliance with all applicable laws and regulations that regulate the inclusion or use of controlled substances, including without limitation, the EU RoHS Directive. **TOSHIBA ASSUMES NO LIABILITY FOR DAMAGES OR LOSSES OCCURRING AS A RESULT OF NONCOMPLIANCE WITH APPLICABLE LAWS AND REGULATIONS.**