

Toshiba BiCD Process Integrated Circuit Silicon Monolithic

TB67S589FNG

BiCD constant-current 2-phase bipolar stepping motor driver IC

1. Description

The TB67S589FNG is a PWM chopper type 2-phase bipolar drive system stepping motor driver IC with PWM chopper type 2-phase bipolar drive. Using the BiCD process, it achieves an output withstand voltage of 50 V and a maximum current of 3.0 A. The motor can be driven by a single VM power supply with a built-in regulator for IC operation.

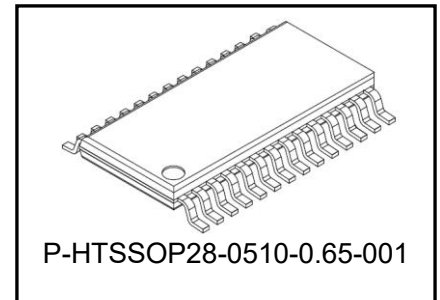

Weight: 0.106 g (Typ.)

2. Features

- BiCD process integrated monolithic IC
- Bipolar stepping motor driver IC
- Advanced Current Detect System (ACDS) functionality enables PWM constant current drive without external current detection resistors
- Advanced Dynamic Mixed Decay (ADMD) function for high-efficiency PWM constant-current drive
- Clock input control
- 2-phase, 1-2 phase, W1-2 phase, 2W1-2 phase, 4W1-2 phase, 8W1-2 phase excitation available
- BiCD structure : DMOSFETs are used for output power transistors
- High withstand voltage and high current: 50 V / 3.0 A (absolute maximum rating)
- Built-in over-temperature detection (TSD), over-current detection (ISD), and low supply voltage detection (UVLO)
- Reduced external components for charge pump
- Package : P-HTSSOP28-0510-0.65-001

Start of commercial production
2023-07

3. Pin assignment

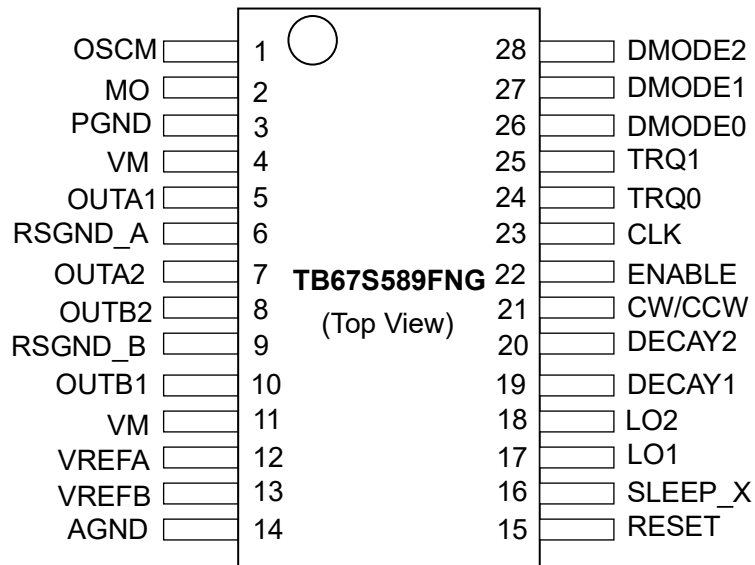

Figure 3 Pin Assignment

4. Block diagram

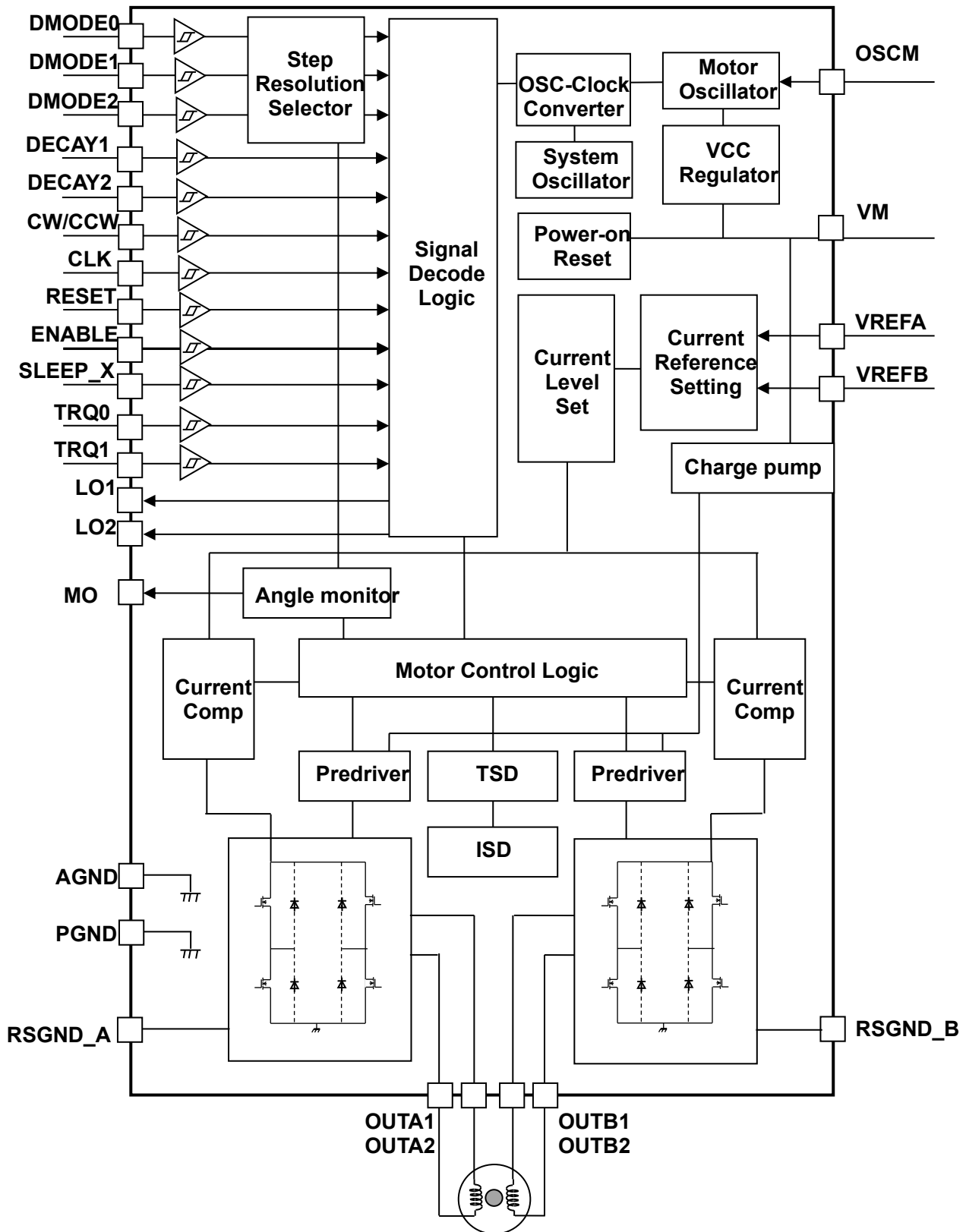

Figure 4 Block diagram

Note: Some of the functional blocks, circuits, or constants in the block diagram may be omitted or simplified for explanatory purpose.

Note: All the grounding wires should be solid patterns and be externally terminated at only one point. Also, a grounding method should be considered for efficient heat dissipation. Careful attention should be paid to the layout of the output, VM and GND traces, to avoid short circuits across output pins or to the power supply or ground. If such a short circuit occurs, the device may be permanently damaged. Also, the utmost care should be taken for pattern designing and implementation of the device since it has power supply pins (VM, OUTA1, OUTA2, OUTB1, OUTB2, AGND, PGND, RSGND_A and RSGND_B) through which a particularly large current may run. If these pins are wired incorrectly, an operation error may occur or the device may be destroyed. The logic input pins must also be wired correctly. Otherwise, the device may be damaged owing to a current running through the IC that is larger than the specified current. Careful attention should be paid to design patterns and mounting.

5. Pin Description

Table 5 Pin Description

No.	Pin name	Description
1	OSCM	Resistor connection pin for setting OSCM
2	MO	Electric angle monitor pin
3	PGND	Motor output GND pin
4	VM	VM voltage input pin
5	OUT_A1	Motor phase-A output pin
6	RSGND_A	Motor phase-A GND pin
7	OUT_A2	Motor phase-A output pin
8	OUT_B2	Motor phase-B output pin
9	RSGND_B	Motor phase B GND pin
10	OUT_B1	Motor phase B output pin
11	VM	VM voltage input pin
12	VREF_A	Reference power supply pin for setting current value of phase A output
13	VREF_B	Reference power supply pin for setting the current value of phase B output
14	AGND	GND pin
15	RESET	RESET signal input pin. Initializes the electric angle.
16	SLEEP_X	SLEEP signal input pin.
17	LO1	Reset signal output pin when abnormality is detected.
18	LO2	Reset signal output pin for abnormality detection.
19	DECAY1	Constant current chopping control switching pin
20	DECAY2	Constant current chopping control switching pin.
21	CW_CCW	Rotation direction switching pin
22	ENABLE	ENABLE signal input pin to control output ON/OFF of phase A and B.
23	CLK	Clock signal input pin. The rising edge advances the electric angle.
24	TRQ0	Torque switching pin.
25	TRQ1	Torque switching pin.
26	DMODE0	Excitation mode setting pin
27	DMODE1	Excitation mode setting pin
28	DMODE2	Excitation mode setting pin

Note: NC pin should be opened.

6. Input / Output Equivalent Circuit

Table 6 Input / Output Equivalent Circuit

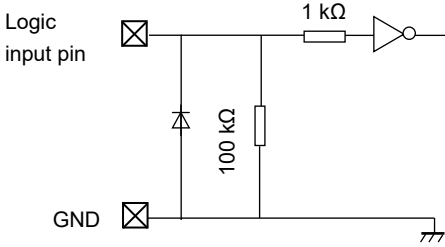
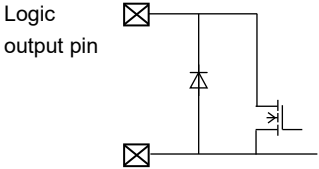
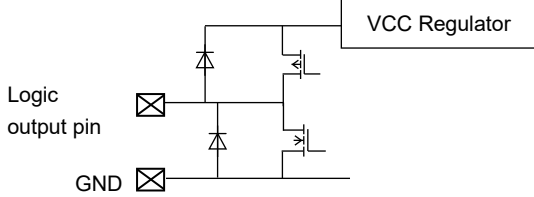
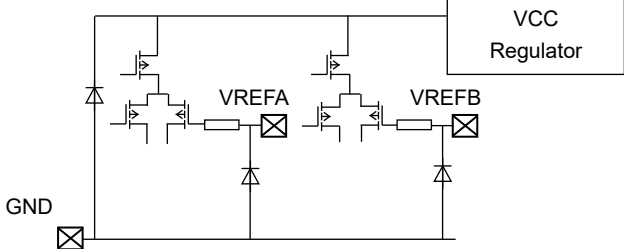
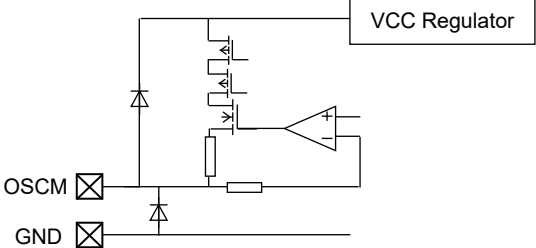
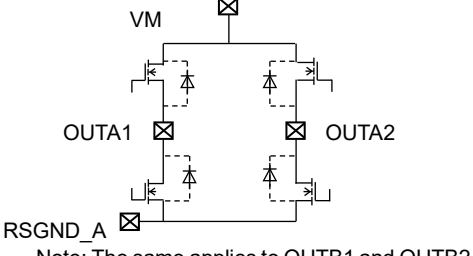
Pin name	Equivalent circuit
CLK ENABLE RESET CW/CCW DMODE0 DMODE1 DMODE2 TRQ0 TRQ1 SLEEP_X DECAY1 DECAY2	
MO LO1	
LO2	
VREFA VREFB	
OSCM	
VM OUTA1 OUTA2 OUTB1 OUTB2 RSGND_A RSGND_B	 <p>Note: The same applies to OUTB1 and OUTB2.</p>

Note: The equivalent circuit diagrams may be simplified for explanatory purposes.

7. Functional Description

7.1. Function of SLEEP_X

The output can be recovered from the forced OFF state due to the operation of the thermal shutdown circuit (TSD)/overcurrent detection circuit (ISD) by setting the device to sleep mode once and then setting it to normal operation mode again. High is input, the device returns to normal operation in 10 ms (max.)

Table7.1 Function of SLEEP_X

SLEEP_X	Function
L	Power saving mode (charge pump stopped, VCC Reg stopped)
H	normal operation

7.2. Function of CLK

Each CLK advances the electric angle by one, and the signal is reflected on the Up edge.

Table7.2 Function of CLK

CLK	Function
↑	Take the next step with an up-edge
↓	-(Hold previous state)

7.3. Function of ENABLE

Switches stepping motor drive ON/OFF. Turning the motor drive ON starts normal constant current control, and setting it to OFF turns the MOSFET OFF and the output is high impedance.

Table7.3 Function of ENABLE

ENABLE	Function
H	Output MOSFET operation : ON (normal operation)
L	Output MOSFET operation : OFF (operation stopped, high impedance)

7.4. Function of CW/CCW

Switches the direction of rotation of the stepping motor.

Table7.4 Function of CW/CCW

CW/CCW	Function
H	Forward(CW)
L	Reverse (CCW)

7.5. Function of DMODE0, DMODE1,DMODE2

Switches step resolution.

Table7.5 Function of DMODE0, DMODE1,DMODE2

DMODE0	DMODE1	DMODE2	Function
L	L	L	Full step resolution setting
L	L	H	Half step resolution (a) setting
L	H	L	Half step resolution (b) setting
L	H	H	Quarter step resolution setting
H	L	L	1/8 step resolution setting
H	L	H	1/16 step resolution setting
H	H	L	1/32 step resolution setting
H	H	H	1/32 step resolution setting

7.6. Sequence by drive mode in clock input control mode

[Full step resolution setting]

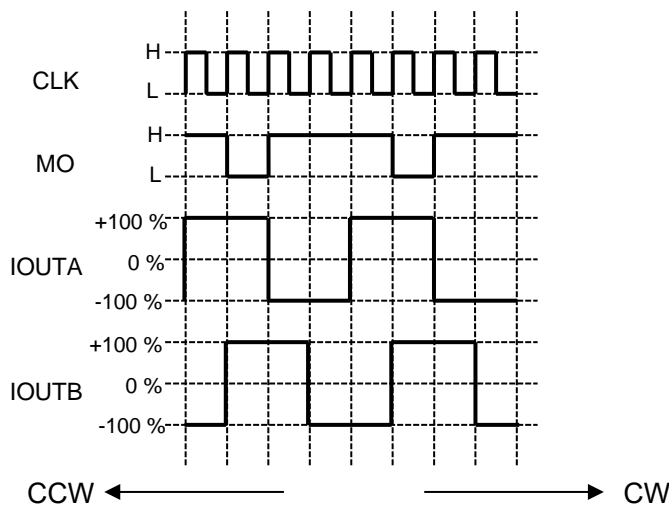

figure7.6.1 Full step resolution setting

[Half step resolution (a) setting]

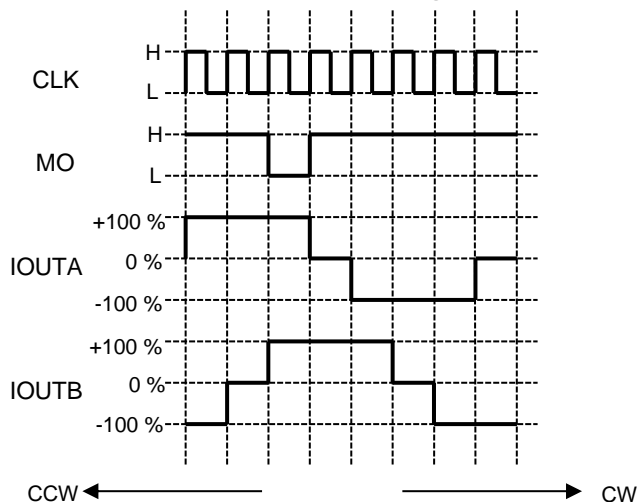

Figure7.6.2 Half step resolution (a) setting

MO output is the terminal waveform in Pull Up state.

Note: The timing chart is simplified to explain the function and operation.

[Half step resolution (b) setting]

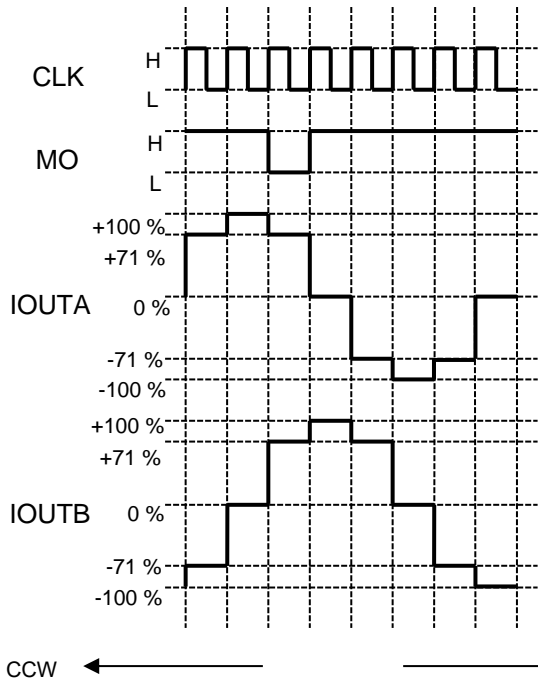

Figure7.6.3 Half step resolution (b) setting

[Quarter step resolution setting]

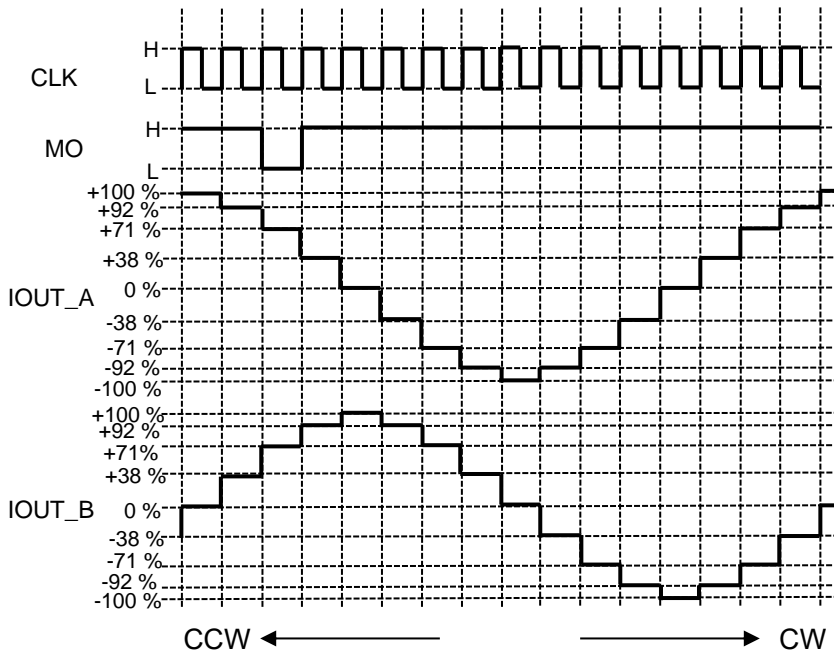

Figure7.6.4 Quarter step resolution setting

MO output is the pin waveform in Pull Up state.

Note: The timing chart is simplified to explain the function and operation.

[1/8 step resolution setting]

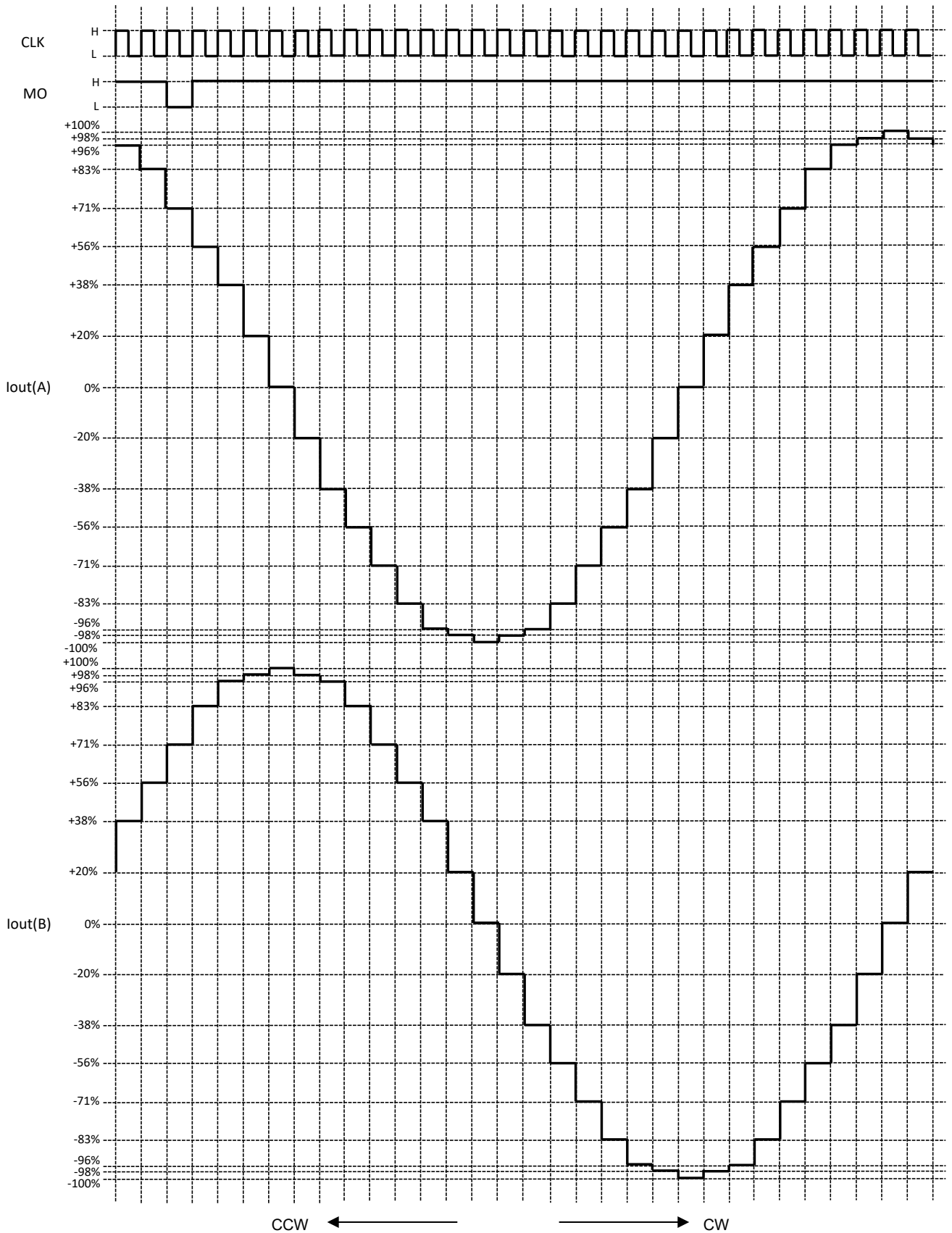

Figure7.6.5 1/8 step resolution setting

MO output is the pin waveform in Pull Up state.

Note: The timing chart is simplified to explain the function and operation.

[1/16 step resolution setting]

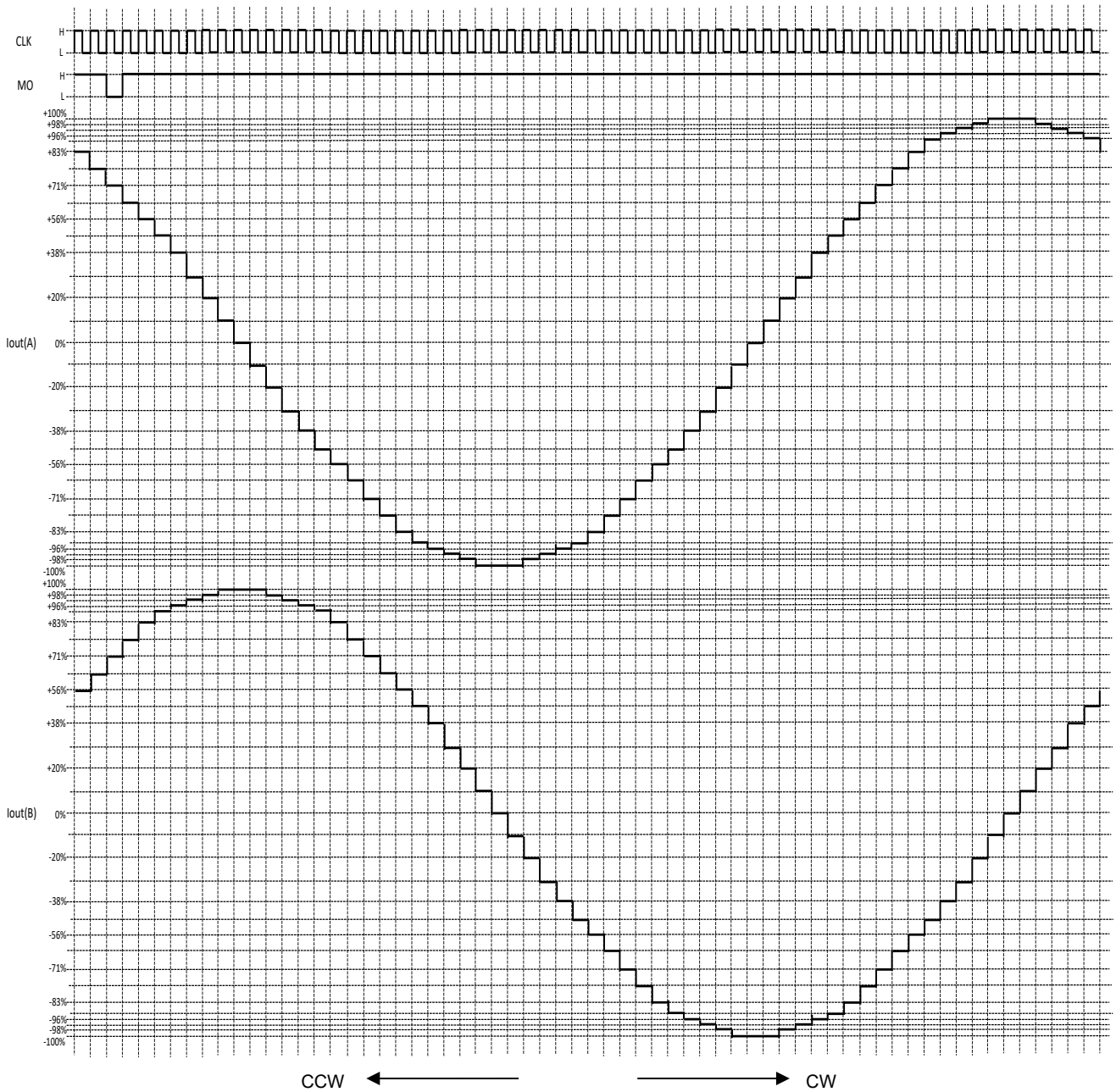

Figure7.6.6 1/16 step resolution setting

MO output is the pin waveform in Pull Up state.

Note: The timing chart is simplified to explain the function and operation.

[1/32 step resolution setting]

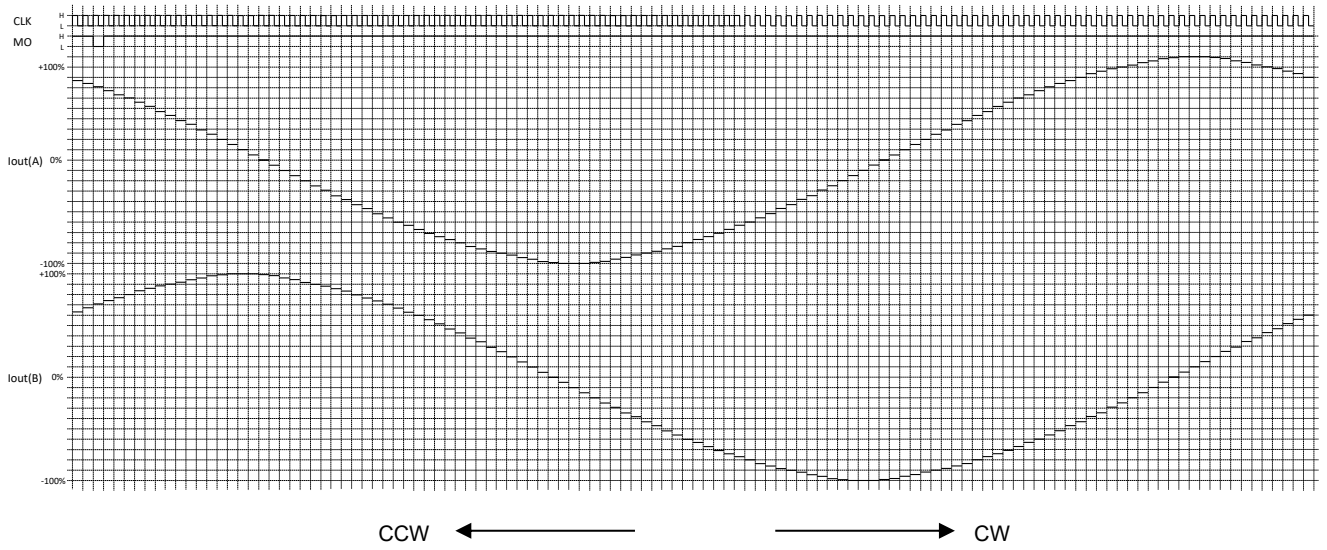

Figure7.6.7 1/32 step resolution setting

MO output is the pin waveform in Pull Up state.

Note: The timing chart is simplified to explain the function and operation.

7.7. Excitation method and set current value

Refer to the table below for Step current for each excitation.
The table is for the case where CW_CCW=High setting.

Table7.7 Excitation method and set current value

STEP	1/32		1/16		1/8		1/4		1/2(b)		1/2(a)		Full	
	Ach (%)	Bch (%)	Ach (%)	Bch (%)	Ach (%)	Bch (%)	Ach (%)	Bch (%)	Ach (%)	Bch (%)	Ach (%)	Bch (%)	Ach (%)	Bch (%)
00	100	0	100	0	100	0	100	0	100	0	100	0		
01	100	5												
02	100	10	100	10										
03	99	15												
04	98	20	98	20	98	20								
05	97	24												
06	96	29	96	29										
07	94	34												
08	92	38	92	38	92	38	92	38						
09	90	43												
010	88	47	88	47										
011	86	51												
012	83	56	83	56	83	56								
013	80	60												
014	77	63	77	63										
015	74	67												
016	71	71	71	71	71	71	71	71	71	71	100	100	100	100
017	67	74												
018	63	77	63	77										
019	60	80												
020	56	83	56	83	56	83								
021	51	86												
022	47	88	47	88										
023	43	90												
024	38	92	38	92	38	92	38	92						
025	34	94												
026	29	96	29	96										
027	24	97												
028	20	98	20	98	20	98								
029	15	99												
030	10	100	10	100										
031	5	100												
032	0	100	0	100	0	100	0	100	0	100	0	100		

STEP	1/32		1/16		1/8		1/4		1/2(b)		1/2(a)		Full	
	Ach (%)	Bch (%)	Ach (%)	Bch (%)	Ach (%)	Bch (%)	Ach (%)	Bch (%)	Ach (%)	Bch (%)	Ach (%)	Bch (%)	Ach (%)	Bch (%)
—														
033	-5	100												
034	-10	100	-10	100										
035	-15	99												
036	-20	98	-20	98	-20	98								
037	-24	97												
038	-29	96	-29	96										
039	-34	94												
040	-38	92	-38	92	-38	92	-38	92						
041	-43	90												
042	-47	88	-47	88										
043	-51	86												
044	-56	83	-56	83	-56	83								
045	-60	80												
046	-63	77	-63	77										
047	-67	74												
048	-71	71	-71	71	-71	71	-71	71	-71	71	-100	100	-100	100
049	-74	67												
050	-77	63	-77	63										
051	-80	60												
052	-83	56	-83	56	-83	56								
053	-86	51												
054	-88	47	-88	47										
055	-90	43												
056	-92	38	-92	38	-92	38	-92	38						
057	-94	34												
058	-96	29	-96	29										
059	-97	24												
060	-98	20	-98	20	-98	20								
061	-99	15												
062	-100	10	-100	10										
063	-100	5												
064	-100	0	-100	0	-100	0	-100	0	-100	0	-100	0		
065	-100	-5												
066	-100	-10	-100	-10										
067	-99	-15												
068	-98	-20	-98	-20	-98	-20								

STEP	1/32		1/16		1/8		1/4		1/2(b)		1/2(a)		Full	
	Ach (%)	Bch (%)	Ach (%)	Bch (%)	Ach (%)	Bch (%)	Ach (%)	Bch (%)	Ach (%)	Bch (%)	Ach (%)	Bch (%)	Ach (%)	Bch (%)
—														
069	-97	-24												
070	-96	-29	-96	-29										
071	-94	-34												
072	-92	-38	-92	-38	-92	-38	-92	-38						
073	-90	-43												
074	-88	-47	-88	-47										
075	-86	-51												
076	-83	-56	-83	-56	-83	-56								
077	-80	-60												
078	-77	-63	-77	-63										
079	-74	-67												
080	-71	-71	-71	-71	-71	-71	-71	-71	-71	-71	-100	-100	-100	-100
081	-67	-74												
082	-63	-77	-63	-77										
083	-60	-80												
084	-56	-83	-56	-83	-56	-83								
085	-51	-86												
086	-47	-88	-47	-88										
087	-43	-90												
088	-38	-92	-38	-92	-38	-92	-38	-92						
089	-34	-94												
090	-29	-96	-29	-96										
091	-24	-97												
092	-20	-98	-20	-98	-20	-98								
093	-15	-99												
094	-10	-100	-10	-100										
095	-5	-100												
096	0	-100	0	-100	0	-100	0	-100	0	-100	0	-100		
097	5	-100												
098	10	-100	10	-100										
099	15	-99												
0100	20	-98	20	-98	20	-98								
0101	24	-97												
0102	29	-96	29	-96										
0103	34	-94												
0104	38	-92	38	-92	38	-92	38	-92						

STEP	1/32		1/16		1/8		1/4		1/2(b)		1/2(a)		Full	
	Ach (%)	Bch (%)	Ach (%)	Bch (%)	Ach (%)	Bch (%)	Ach (%)	Bch (%)	Ach (%)	Bch (%)	Ach (%)	Bch (%)	Ach (%)	Bch (%)
—														
0105	43	-90												
0106	47	-88	47	-88										
0107	51	-86												
0108	56	-83	56	-83	56	-83								
0109	60	-80												
0110	63	-77	63	-77										
0111	67	-74												
0112	71	-71	71	-71	71	-71	71	-71	71	-71	100	-100	100	-100
0113	74	-67												
0114	77	-63	77	-63										
0115	80	-60												
0116	83	-56	83	-56	83	-56								
0117	86	-51												
0118	88	-47	88	-47										
0119	90	-43												
0120	92	-38	92	-38	92	-38	92	-38						
0121	94	-34												
0122	96	-29	96	-29										
0123	97	-24												
0124	98	-20	98	-20	98	-20								
0125	99	-15												
0126	100	-10	100	-10										
0127	100	-5												
0128	100	0	100	0	100	0	100	0	100	0	100	0		

7.8. Selectable Mixed Decay Function

Selectable Mixed Decay is a function that allows the amount of current regeneration during the current regeneration (decay) period to be adjusted by the DECAY pin. Mixed Decay control itself is achieved by switching between the three control modes of Chage, Slow, and Fast, and the DECAY pin allows this constant-current control to be selected from among four settings. If this setting is switched during constant current operation, the new setting will be applied from the next chopping cycle.

Table7.8 Selectable Mixed Decay Function

DECAY2	DECAY1	Function
L	L	Mixed Decay
L	H	Slow Decay only
H	L	Fast Decay only
H	H	ADMD

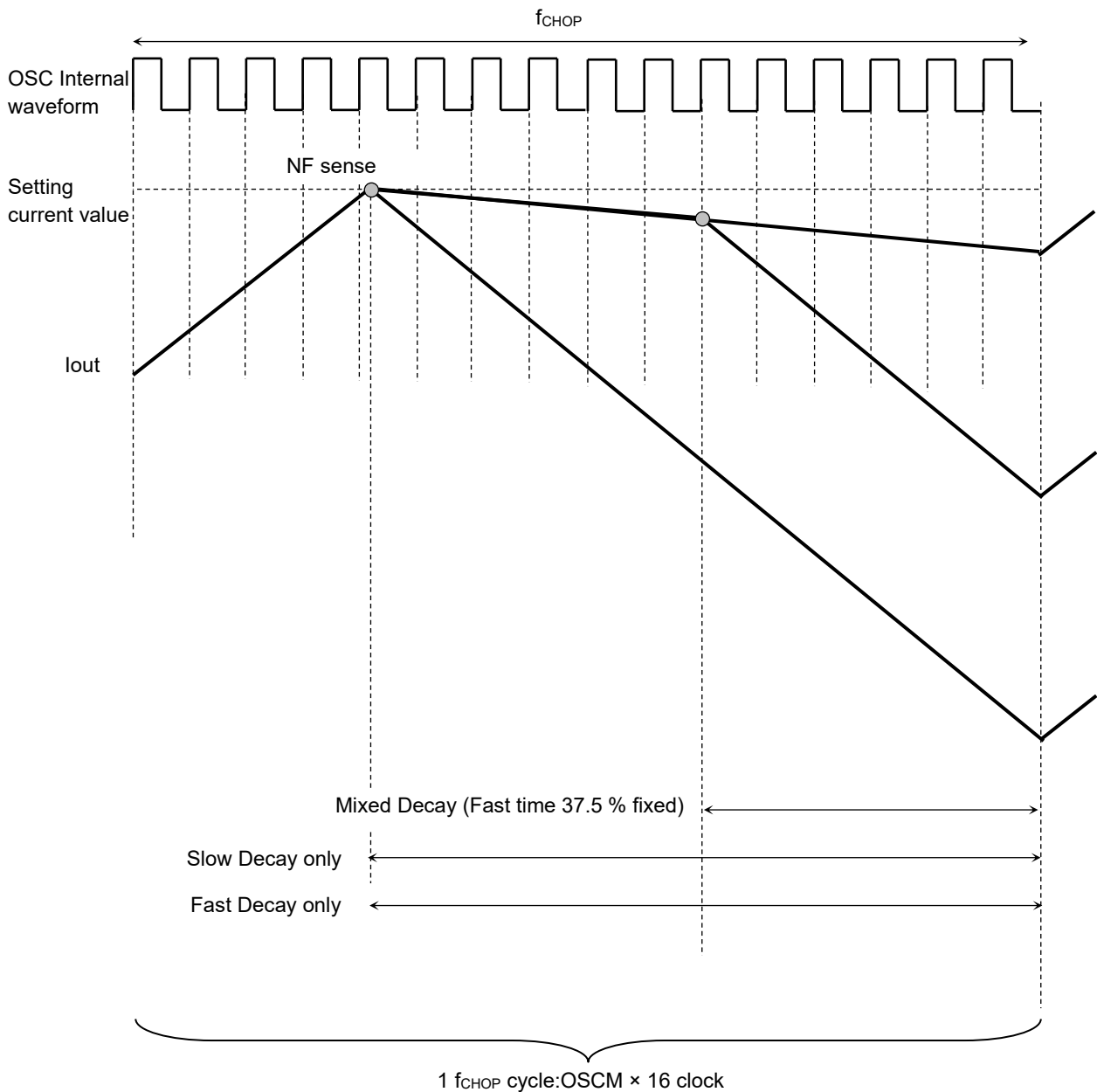

Figure7.8 Selectable Mixed Decay Function

Note: Timing charts are simplified to illustrate functions and operations.

7.9. Mixed Decay current waveform 1

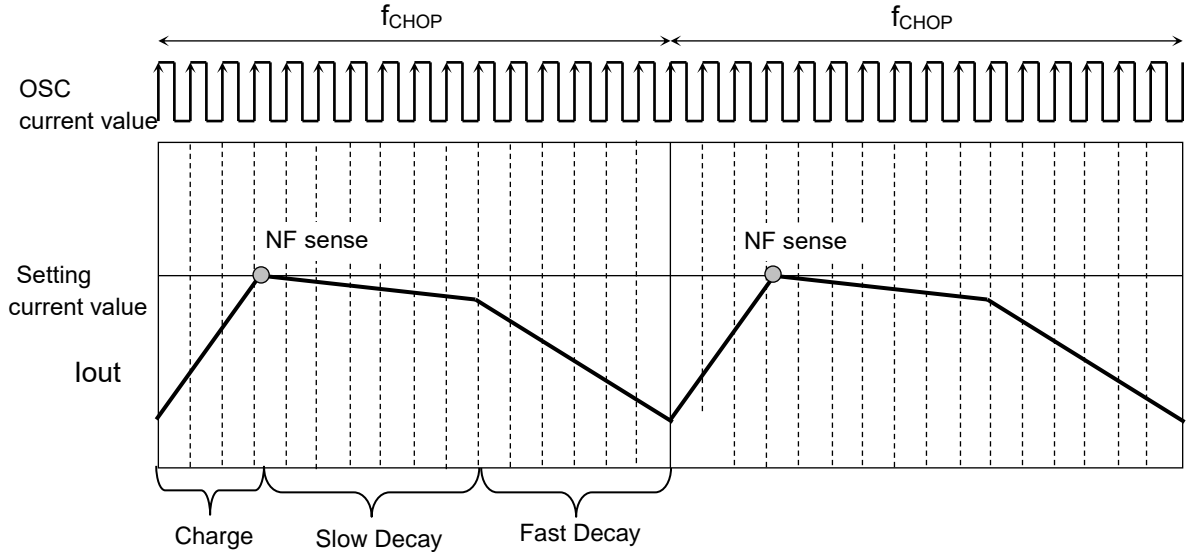

Figure7.9 Mixed Decay waveform

Note: Timing charts are simplified to illustrate functions and operations.

7.10. For each time of constant-current PWM operation

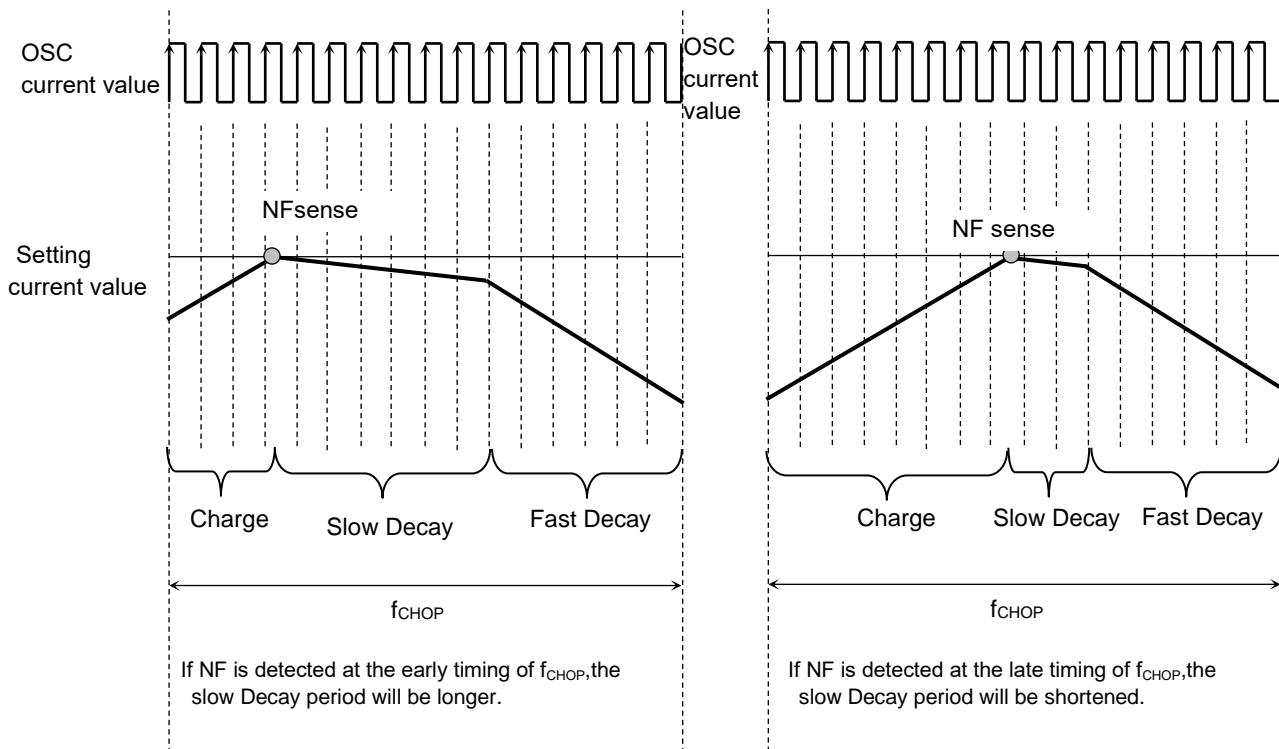

Figure7.10 Each time of constant-current PWM operation

The time required for the current flowing in the motor to reach the set current value (charge period) varies depending on the drive conditions.

The timing of NF detection (motor current reaching the set current value) during the mixed decay chopping cycle (f_{CHOP}) varies from time to time. As shown in the example above, if NF is detected at a relatively early timing, the Slow Decay period will be longer, and if it is detected later, the Slow Decay period will be shorter.

Note: Basically, f_{CHOP} time - (Charge + Fast decay time) = Slow decay time.

(Fast decay time is fixed at 37.5 % (OSCM: 6 CLK minutes).

Note: Timing chart is simplified to explain functions and operations.

7.11. Mixed Decay current waveform 2

- If the set current value is in the increasing direction

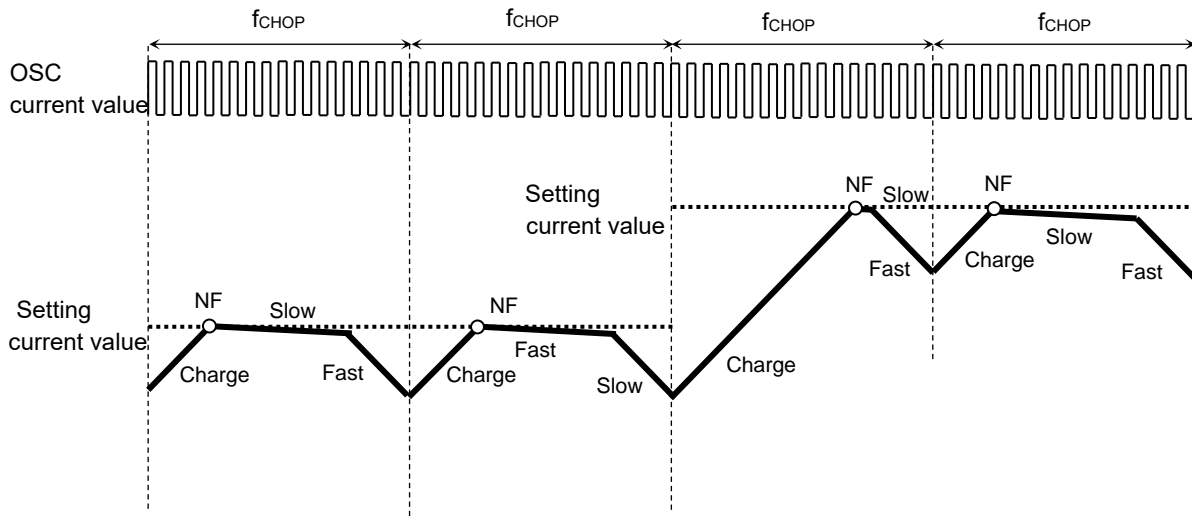

Figure7.11.1 If the set current value is in the increasing direction

- If the Charge period is more than one f_{CHOP} cycle

If the period of time (Charge period) until the motor current reaches the next set value (step), such as when switching the set current value (step), exceeds one cycle of the set chopping cycle (f_{CHOP}), Charge continues for the next f_{CHOP} cycle, and after reaching NF, the motor transitions to Mixed Decay control.

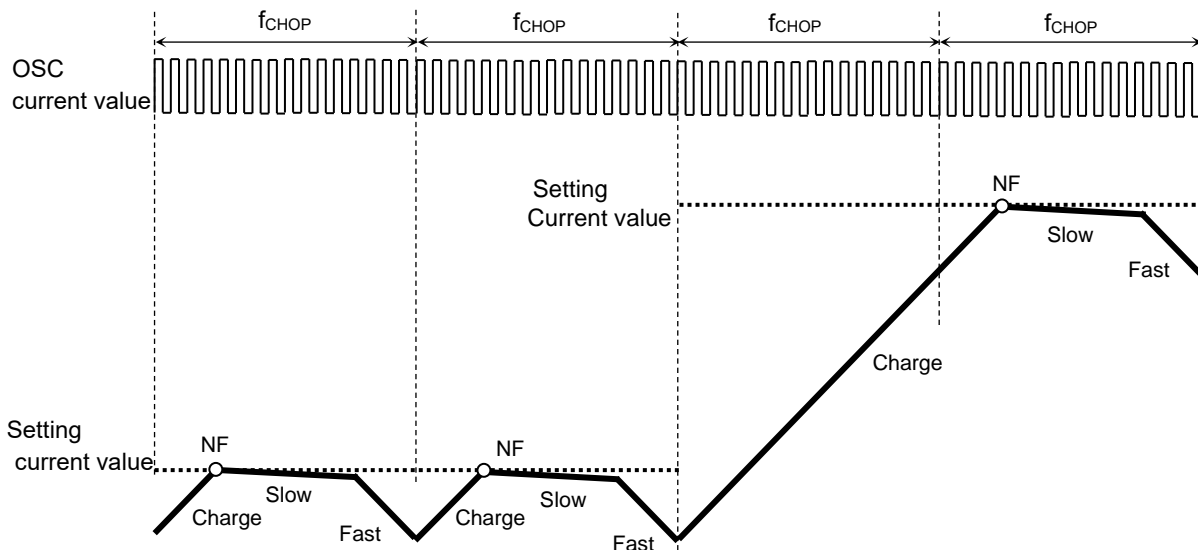

Figure7.11.2 If the Charge period is more than one f_{CHOP} cycle

● If the set current value is in the decreasing direction

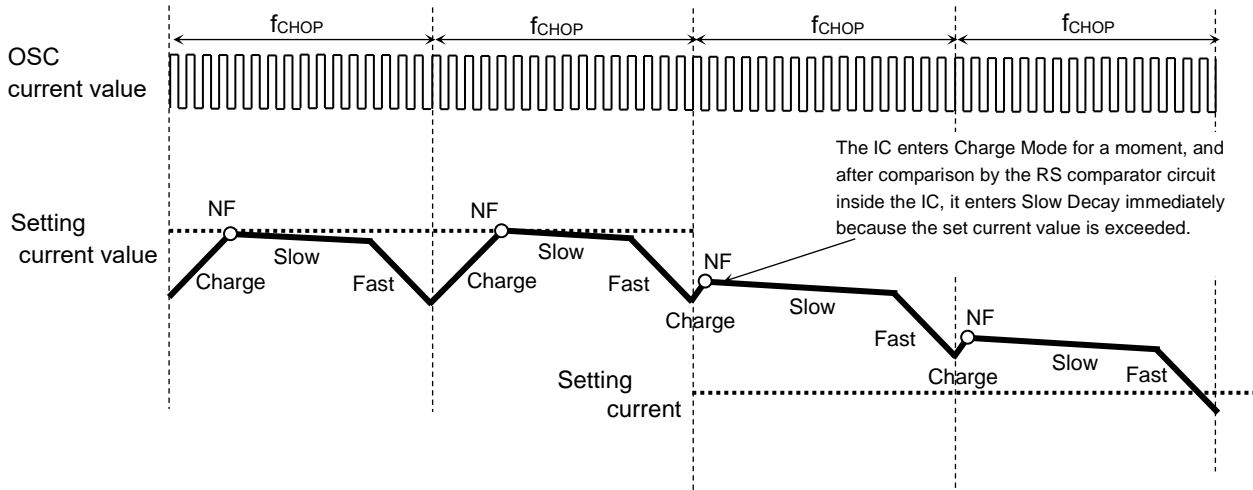

Figure7.11.3 If the set current value is in the decreasing direction

Note: Timing charts are simplified to explain functions and operations.

7.12. ADMD (Advanced Dynamic Mixed Decay) Constant current control

ADMD monitors both the current flowing from the power supply to the motor and the current regenerated from the motor to the power supply, and performs constant-current PWM control. The basic sequence of ADMD is as follows

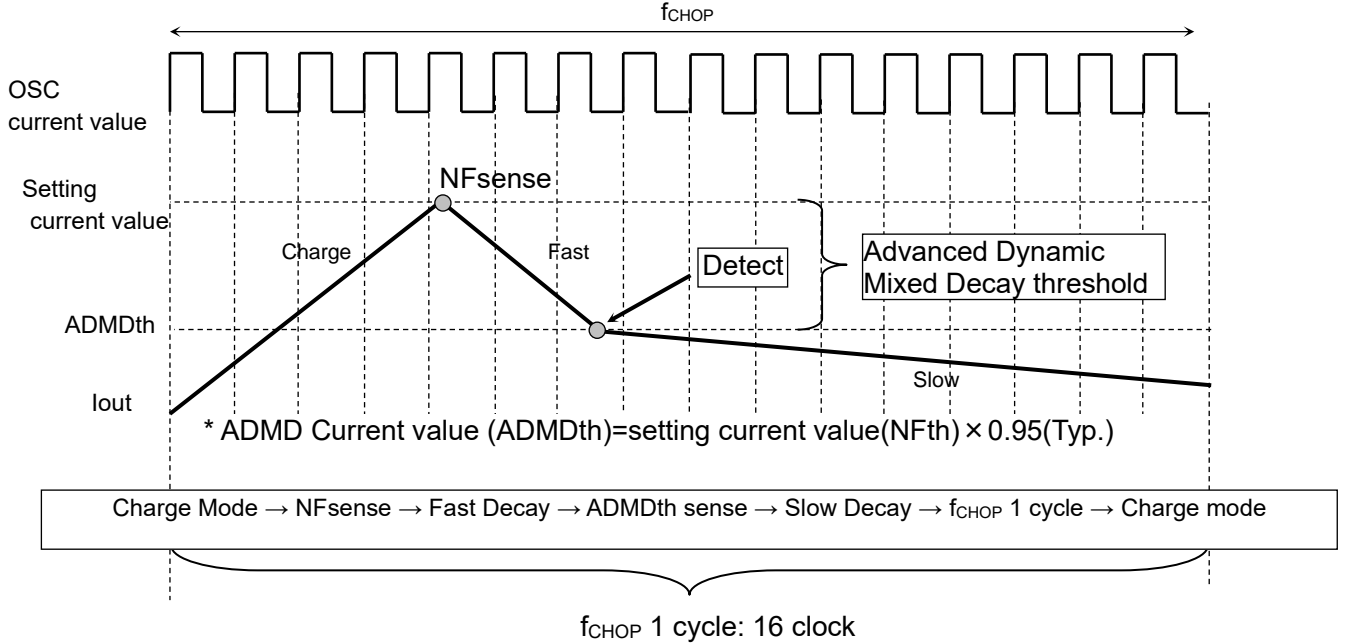

Figure7.12.1 ADMD (Advanced Dynamic Mixed Decay) Constant current control 1

Note: Timing charts are simplified to explain functions and operations. Values in the timing chart are for reference only.

Various filters are set as follows to prevent current mis-detection due to external noise jumps, etc. If the L value of the motor used is small and the current value reaches ADMDth (ADMD current value) within the ADMDtblank period, the motor switches to Slow operation after the ADMDtblank period. In this case, the ADMD current value (ADMDth) is smaller than the set current value (NFth) x 0.95 (Typ.).

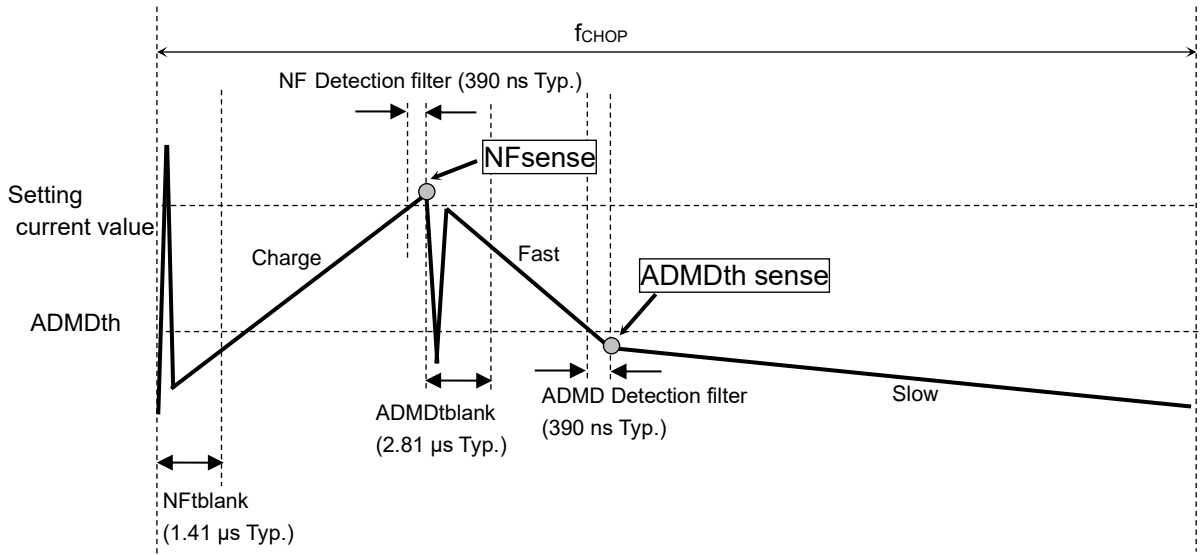

Figure7.12.2 ADMD (Advanced Dynamic Mixed Decay) Constant current control 2

Note: The timing chart is simplified to explain functions and operations. Values in the timing chart are for reference only.

7.13. ADMD (Advanced Dynamic Mixed Decay) current waveform 1

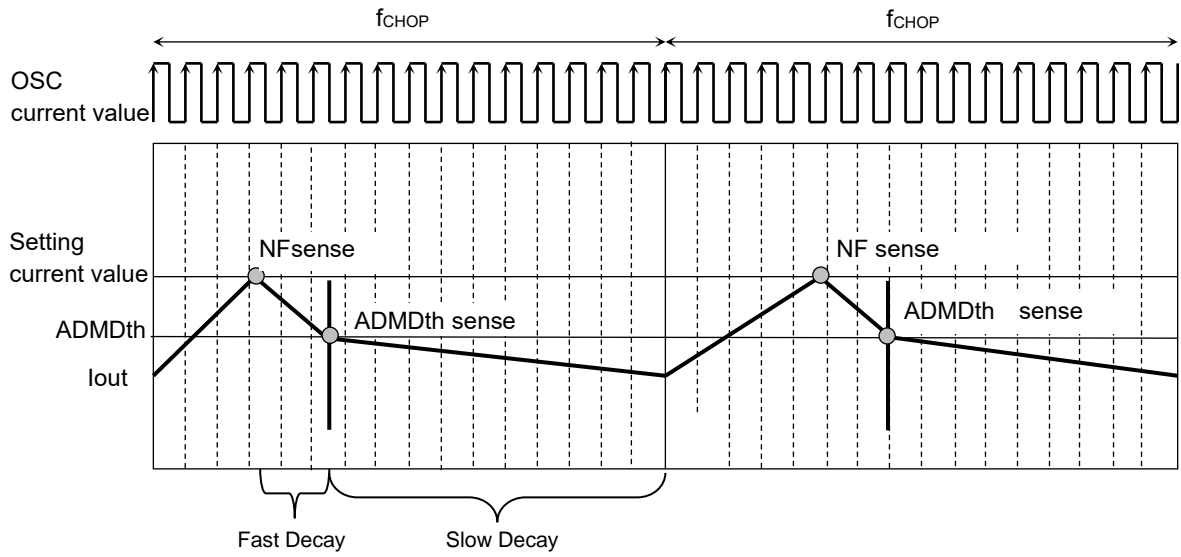

Figure7.13 ADMD (Advanced Dynamic Mixed Decay) current waveform

Note: Timing charts are simplified to explain functions and operations.

7.14. ADMD (Advanced Dynamic Mixed Decay) current waveform 2

- If the set current value is in the increasing direction

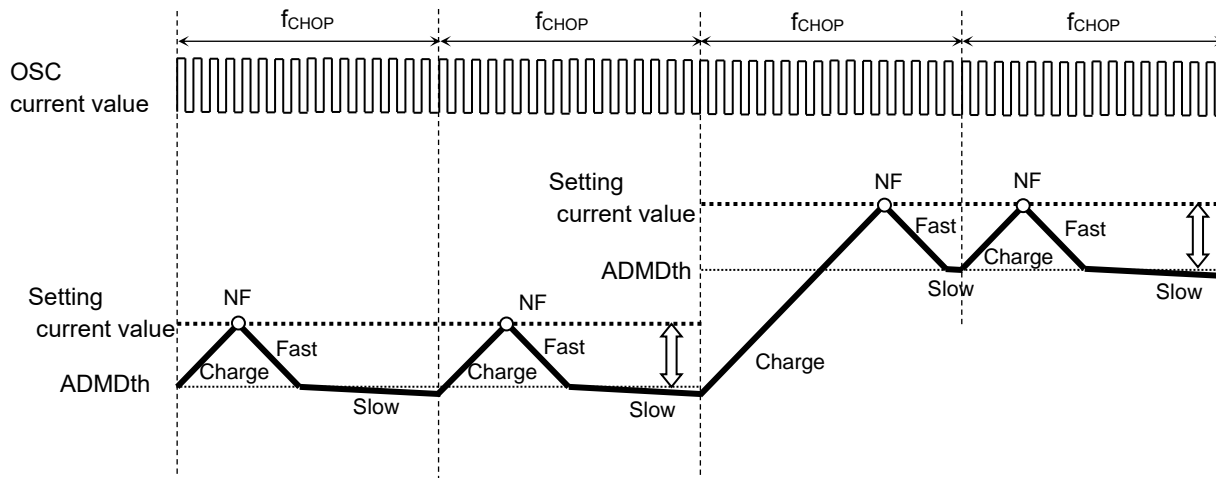

Figure7.14.1 If the set current value is in the increasing direction

- **Charge period is more than one f_{CHOP} cycle**

If the period of time (Charge period) until the motor current reaches the next set value (step), such as when switching the set current value (step), exceeds one cycle of the set chopping cycle (f_{CHOP}), Charge continues for the next f_{CHOP} cycle, and after reaching NF, the motor shifts to ADMD control.

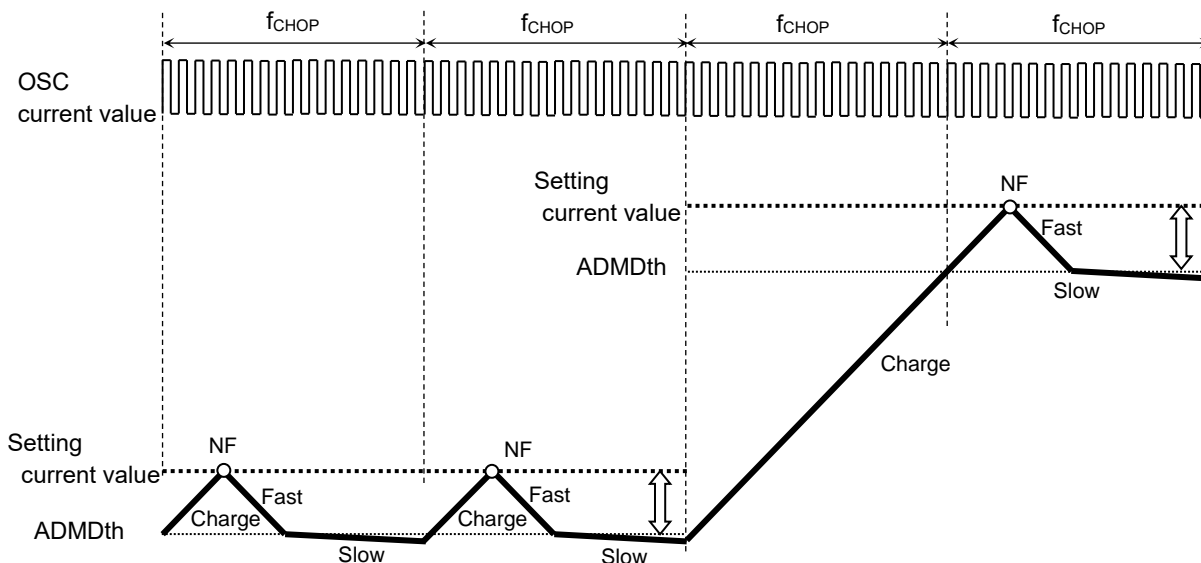

Figure7.14.2 If the Charge period is more than one f_{CHOP} cycle

Note: Timing charts are simplified to explain functions and operations.

- If the set current value is in the decreasing direction

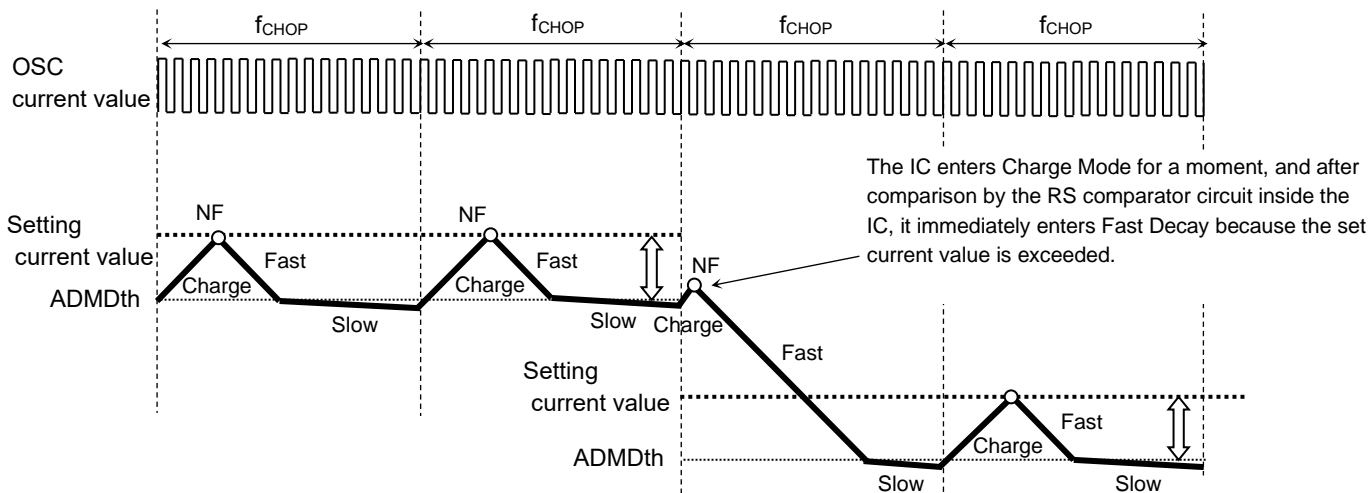

Figure7.14.3 If the set current value is in the decreasing direction

- If the Fast period is more than one f_{CHOP} cycle
(Output current does not reach ADMD threshold within f_{CHOP} 1 cycle)

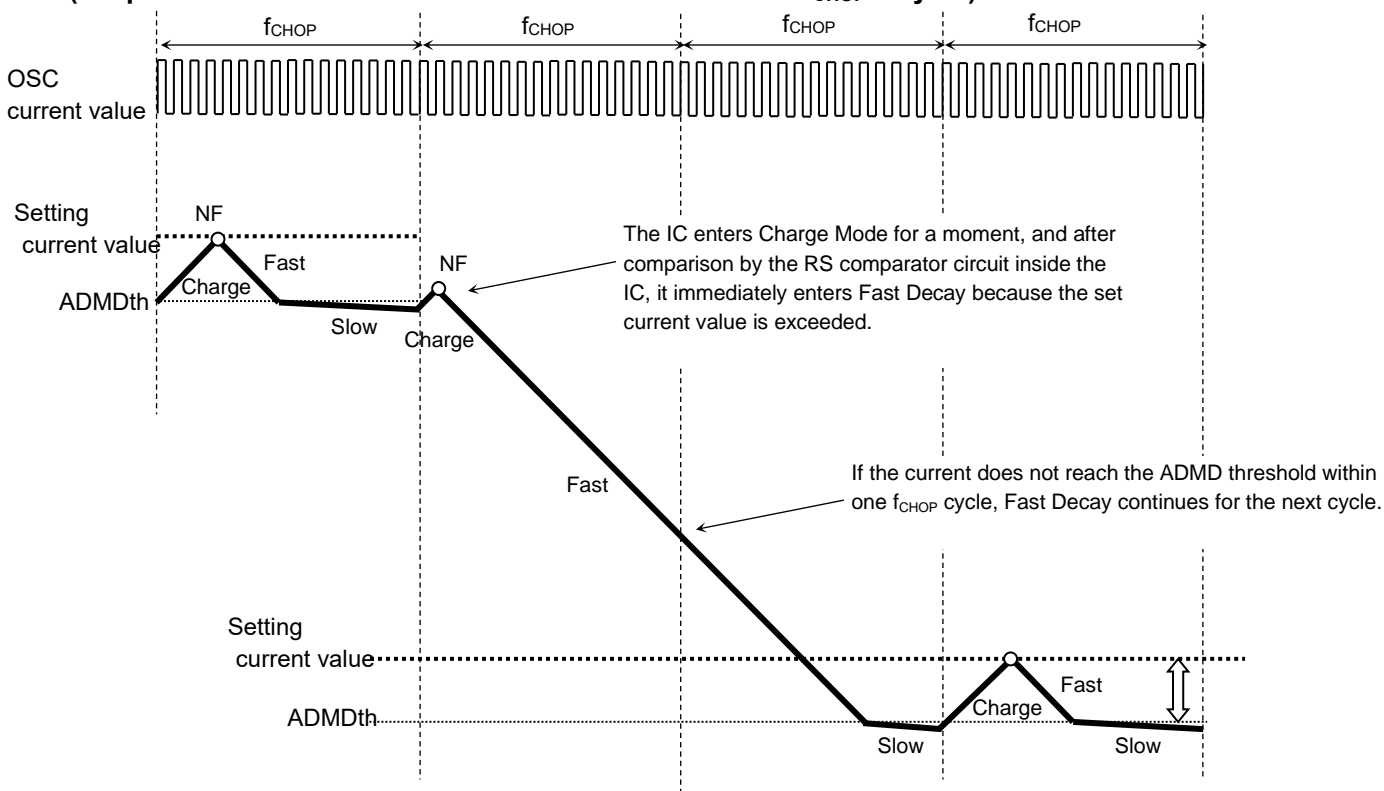

Figure7.14.4 If the Fast period is more than one f_{CHOP} cycle

Note: Timing charts are simplified to illustrate functions and operations.

7.15. Function of RESET

The internal electric angle can be initialized.

Table7.15.1 Function of RESET

RESET	Function
H	Electric angle initialization
L	normal operation

The current in each phase when RESET is applied is as follows.

Table7.15.2 Each phase current when RESET is applied

excitation mode	Phase A current	Phase B current	Initial electric angle
Full step resolution setting	100 %	100 %	45 °
Half step resolution (a) setting	100 %	100 %	45 °
Half step resolution (b) setting	71 %	71 %	45 °
Quarter step resolution setting	71 %	71 %	45 °
1/8 step resolution setting	71 %	71 %	45 °
1/16 step resolution setting	71 %	71 %	45 °
1/32 step resolution setting	71 %	71 %	45 °

7.16. Torque Function

This pin is used to set the torque of the motor.

Table7.16 Torque Function

TRQ1 pin input	TRQ0 pin input	Function
L	L	Torque setting: 100 %
L	H	Torque setting: 75 %
H	L	Torque setting: 50 %
H	H	Torque setting: 25 %

7.17. Function of MO

Internal electrical angle can be checked by connecting the output of the MO pin to a potential of 3.3 V or 5 V with a 10 k ~ 100 kΩ pull-up resistor.

Table7.17 Function of MO

MO	Function
H (at pull-up)	Electric angle is other than the initial value
L	Initial value of electric angle

7.18. LO (error detection flag output) Function

The LO function outputs an external signal when the error detection function is activated. Since this is an open drain pin, when using the function, connect the LO1 and LO2 pin outputs to 3.3 V or 5 V potential with a 10 kΩ to 100 kΩ pull-up resistor. In normal operation, the LO1 pin level is Hi-Z (internal MOSFET is OFF). If the error detection function (over-temperature (TSD), over-current (ISD), etc.) is activated, the pin level becomes Low (internal MOSFET is ON). If the LO pin is not used, leave it open. The LO2 pin goes Low only when a TSD is detected.

Table7.18.1 LO1 Function

LO1 output pin	Function
H(at pull-up)	Normal state (normal operation)
L	Overcurrent detection (ISD), Thermal shutdown (TSD) status

Table7.18.2 LO2 Function

LO2 output pin	Function
H(at pull-up)	Normal state (normal operation)
L	Thermal shutdown (TSD) status

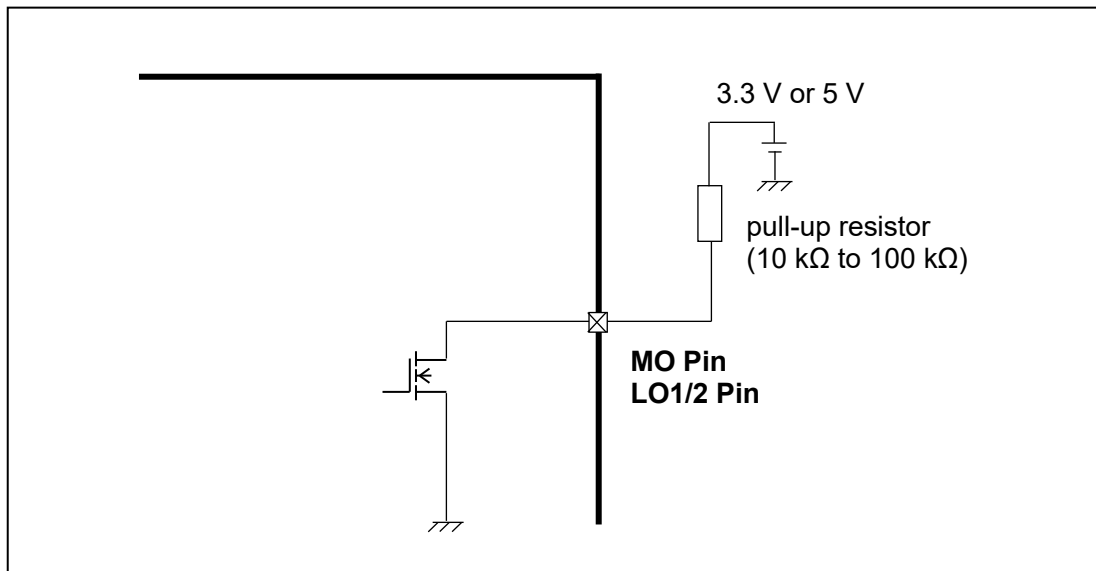

Figure7.18 LO Function

Note: Equivalent circuits may be partially omitted or simplified to explain the circuit.

8. Output stage transistor operation mode (Advanced Dynamic Mixed Decay)

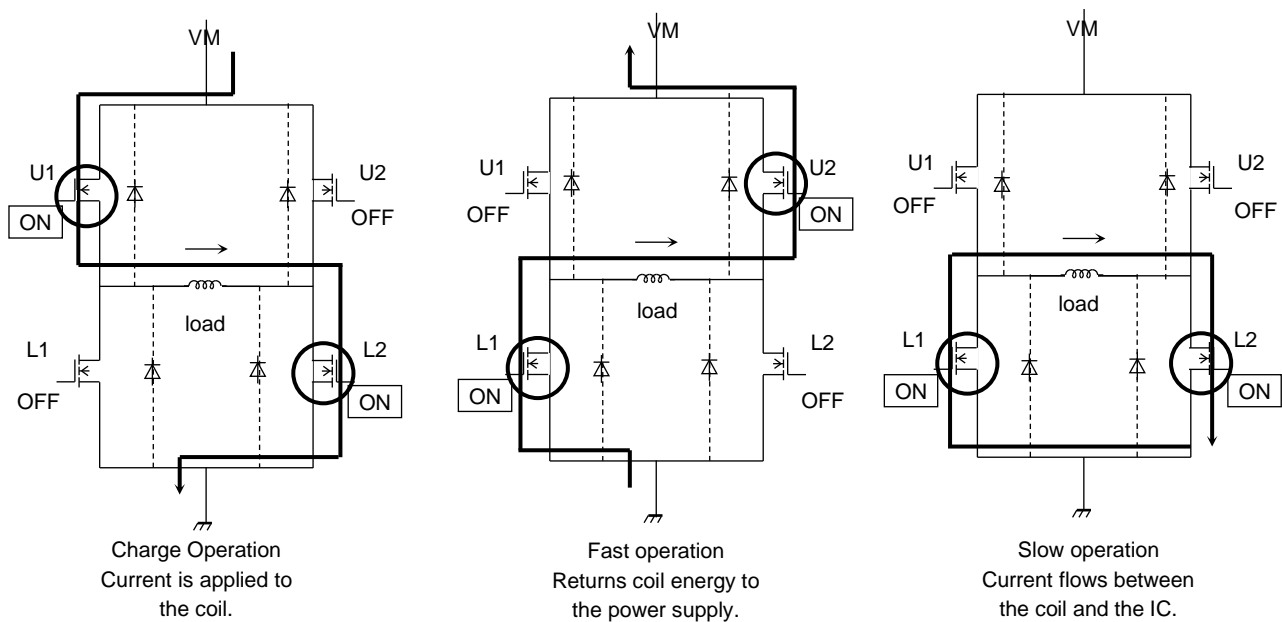

Figure8 Output stage transistor operation mode (Advanced Dynamic Mixed Decay)

Note: When switching outputs, the IC has an internal time to prevent through-current.

8.1. Functions of output stage transistor operation

Table8.1.1 Function of output stage transistor operation 1

Mode	U1	U2	L1	L2
CHARGE	ON	OFF	OFF	ON
FAST	OFF	ON	ON	OFF
SLOW	OFF	OFF	ON	ON

Note: The table above shows the case where the current flows in the direction of the arrow in the figure above as an example.

For the opposite direction, the table below is used.

Table8.1.2 Function of output stage transistor operation 2

Mode	U1	U2	L1	L2
CHARGE	OFF	ON	ON	OFF
FAST	ON	OFF	OFF	ON
SLOW	OFF	OFF	ON	ON

Note: This IC automatically switches between the three modes shown in the above figure and performs constant-current control.

Equivalent circuits are partially omitted or simplified to explain the circuit.

9. About the set current value (I_{OUT})

The set current value during constant-current PWM control can be set by the reference voltage (V_{REF}) and RS resistance value.

The set current value (I_{OUT}) can be calculated by the following formula.

$$I_{OUT} = V_{REF} \times 0.833$$

Example: If $V_{REF} = 3.6 \text{ V}$, $I_{OUT} = 3.0 \text{ A}$

10. About chopping frequency (f_{CHOP})

The chopping frequency of the constant current control of the motor current can be set by the resistor R_{OSC} connected to the OSCM terminal. It is also possible to use a fixed value chopping frequency without any external components attached to the OSCM terminals.

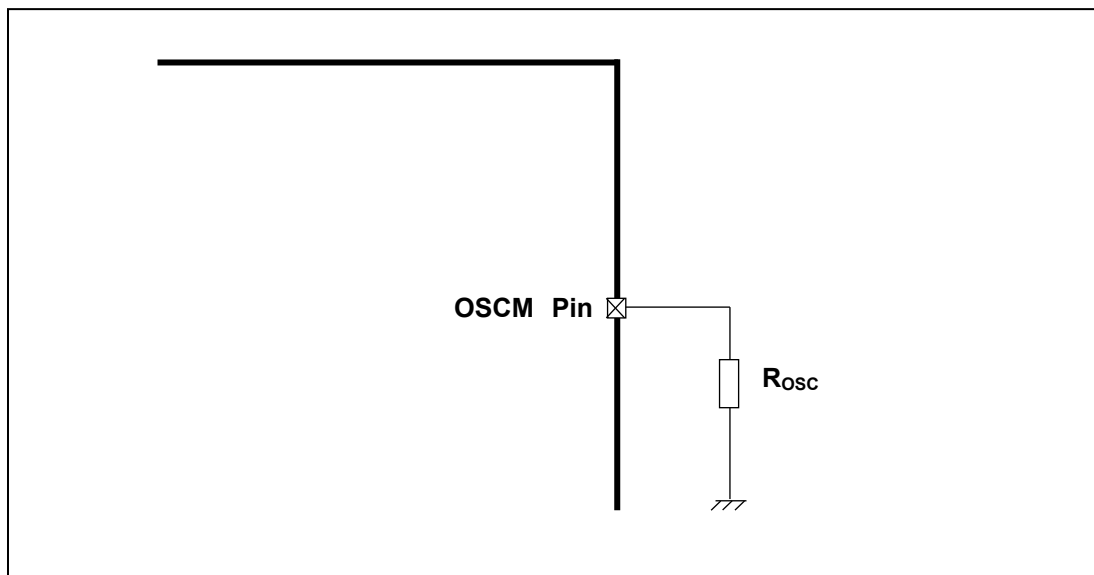

Figure10 About chopping frequency (f_{CHOP})

Note: Equivalent circuits may be partially omitted or simplified to explain the circuit.

The chopping frequency (f_{CHOP}) can be calculated using the following formula.

Generally, it is recommended that the frequency be set in the range of 40 kHz to 100 kHz with a reference frequency of about 70 kHz.

$$f_{CHOP} = f_{OSCM} / 16$$

$$f_{OSCM} = 1 / (\alpha \times R_{OSC} + \beta) \text{ [MHz]} \quad \alpha = 1.7 \times 10^{-5}, \beta = 0.0285$$

Example : If $R_{OSC}=47 \text{ k}\Omega$, $f_{OSCM}=1.2 \text{ MHz}$ (Typ.), $f_{CHOP}=75 \text{ kHz}$ (Typ.)

With the OSCM pin open or GND shorted, the frequency $f_{OSCM2}=914 \text{ kHz}$ (Typ.) automatically generated inside the IC, $f_{CHOP}=57.1 \text{ kHz}$ (Typ.).

11. Power Consumption of IC

The power consumed by an IC can be roughly divided into two parts: the power consumed by the transistors in the output section and the power consumed by the logic section.

11.1. Power consumption of power transistor section

The power in the output section is consumed by the transistors above and below the H-bridge.

The power in the transistor section of an H-bridge can be expressed by the following equation

$$P(\text{out}) = I_{\text{out}}(\text{A}) \times V_{\text{DS}}(\text{V}) = I_{\text{out}}(\text{A})^2 \times R_{\text{on}}(\Omega) \dots \dots \dots (1)$$

The average power consumption of the output in the case of full step resolution setting and a perfect square waveform of the output current waveform can be calculated as follows

The average power consumption of the output can be calculated as follows.

$$R_{\text{on}} = 0.4 \Omega, I_{\text{out}}(\text{peak : Max}) = 1.0 \text{ A}, V_{\text{M}} = 24 \text{ V} \text{ then the following can be calculated.}$$

$$P(\text{out}) = 2(\text{Tr}) \times 1.0(\text{A})^2 \times 0.4(\Omega) \dots \dots \dots (2)$$

$$= 0.8(\text{W})$$

11.2. Power consumption of logic and IM systems

Then the calculation can be done as follows. The power consumption of the logic and IM system is calculated separately for operating and stopped conditions.

- I (I_{M3}) = 7.5 mA (Typ.): operation/axis
- I (I_{M2}) = 4.8 mA (Typ.): stopped/axis
- I (I_{M1}) = 0.03 μA (Typ.) : standby/axis

The output system is connected to V_M (24 V). (Output system: Current consumed by the circuit connected to V_M and current consumed by the output stage when switching.

Power consumption can be estimated as follows

$$P(I_{\text{M3}}) = 24(\text{V}) \times 0.0075(\text{A}) \dots \dots \dots (3)$$

$$= 0.18(\text{W})$$

11.3. Power consumption

From the results of 1 and 2, the overall power consumption, P, can be calculated as follows

$$P = P(\text{out}) + P(I_{\text{M3}}) = 0.98(\text{W})$$

In addition, the power consumption for one axis in standby is as follows

$$P(\text{standby}) = 24(\text{V}) \times 0.03(\mu\text{A}) = 0.72(\mu\text{W})$$

For the thermal design of the board, etc., please set with a margin after sufficient evaluation of the mounting.

12. About the detection function

The following detection functions are available

Table12 About the detection function

Detection function	Detection location	Detection level	Action at detection	Method of recovery from detection state
Overheat detection (TSD)	Chip temperature	160 °C (Typ.) or higher 5.0 μs (Typ.) dead zone time	All outputs forced OFF	This function is a latch type that maintains the operation at the time of detection. It is restored by one of the following processes. Turn on the power again. Set the device to sleep mode and then set it to normal operation mode again.
Overcurrent detection (ISD)	Output current	4.5 A (Typ.) min. 1.25 μs (Typ.) dead zone time	All outputs forced OFF	
Low supply voltage (UVLO)	VM Pin Voltage	4.0 V (Typ.) or less With 1.41 μs (Typ.) dead zone time	All outputs forced OFF Internal circuit reset	Increase VM voltage to 4.2 V (Typ.) or higher

13. Overheat detection (This function is a latch type that maintains operation at the time of detection.)

This function temporarily stops IC operation when abnormal overheating of the device occurs. A dead-time period is set for overheat detection to prevent false detection due to external noise. When overheat is detected, all channels are turned off.

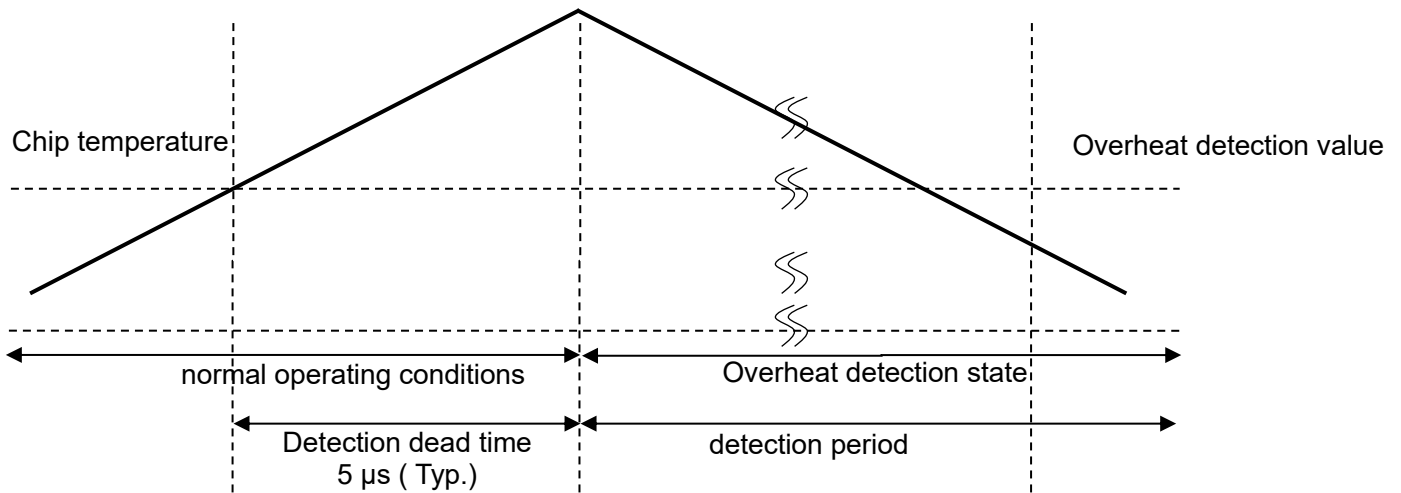

Figure13 Overheat Detection

Note: The timing chart is simplified to explain functions and operations. Values in the timing chart are for reference only.

14. Overcurrent detection (This function is a latch type that maintains operation at the time of detection.)

This function temporarily stops IC operation in the event of a short between motor outputs, or a power/ground fault.

For overcurrent detection, a dead-time period is set to prevent false detection due to spike currents during switching or noise from external sources. When an overcurrent is detected, not only the corresponding channel but also both channels are turned off.

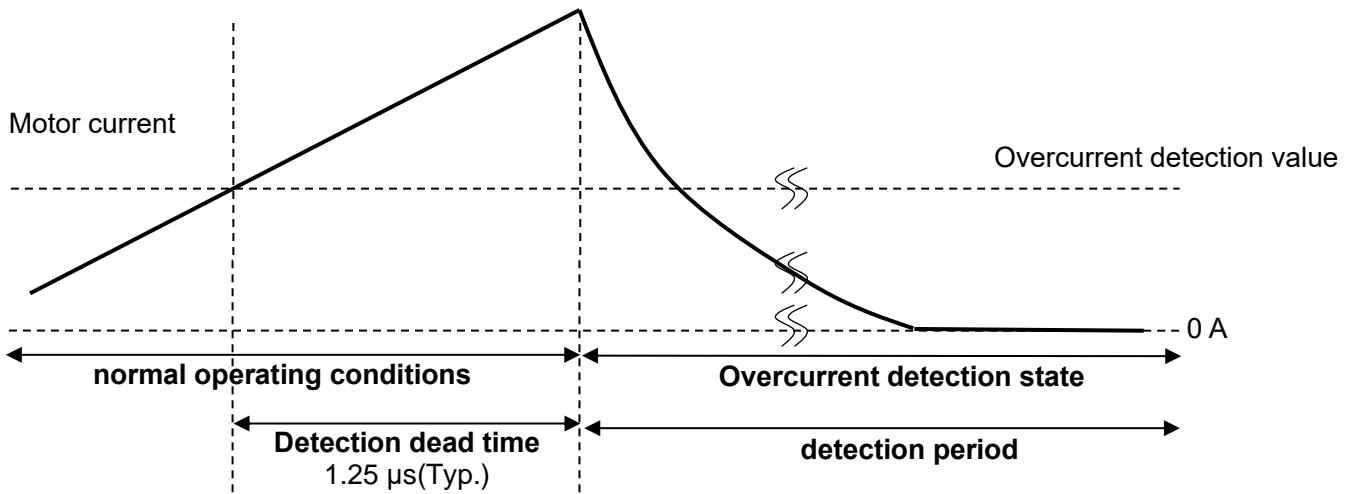

Figure14 Overcurrent detection

Note: The timing chart is simplified to explain functions and operations. Values in the timing chart are for reference only.

15. Absolute Maximum Ratings ($T_a = 25\text{ }^\circ\text{C}$)

Table15 Absolute Maximum Ratings

Entry	Symbol	rated value	Unit
Motor power supply voltage	V_M	45	V
Motor output voltage	V_{OUT}	50	V
Motor output current (Note 1)	I_{OUT}	3.0	A
Internal regulator voltage	V_{CC}	6.0	V
Logic input pin voltage	V_{IN}	6.0	V
Vref reference voltage	V_{ref}	6.0	V
MO,LO Pin Voltage	V_{MO}	6.0	V
Power Dissipation(Note2)	P_D	4.0	W
Operating temperature	T_{opr}	-40 to 85	$^\circ\text{C}$
Storage Temperature	T_{stg}	-55 to 150	$^\circ\text{C}$
Junction Temperature	$T_{j(MAX)}$	150	$^\circ\text{C}$

Note 1: The maximum current value under normal conditions should be 2.7 A or less per equivalent after thermal calculation. Depending on the ambient temperature and board conditions, the current may be further limited due to heat generation conditions.

Note 2: JEDEC compliant 4-layer board mounting ($T_a = 25\text{ }^\circ\text{C}$)
If T_a exceeds $25\text{ }^\circ\text{C}$, derating at $32.0\text{ mW}/^\circ\text{C}$ is required.

T_a : The ambient temperature of the IC.

T_{opr} : The ambient temperature of the IC at the time of operation.

T_j : The chip temperature of the IC during operation. t_j maximum value is limited by the temperature of the TSD (thermal shutdown circuit).

It is recommended that the maximum value of T_j be designed considering the maximum current in use, which should be around $120\text{ }^\circ\text{C}$.

Absolute maximum ratings

Absolute maximum ratings are standards that must not be exceeded even momentarily.

Exceeding the absolute maximum ratings may cause destruction, degradation, or damage to the IC, or may cause destruction, damage, or degradation to other ICs.

Always design the product so that the absolute maximum ratings are not exceeded under any operating conditions.

In addition, this product is not equipped with an overvoltage detection circuit.

Therefore, the IC will be destroyed if an excessive voltage above the Spec is applied.

Please be sure to use each voltage range, including supply voltage, within the Spec.

Please also refer to the precautions section on the following page for more information on this precaution

16. PD-Ta graph (for reference)

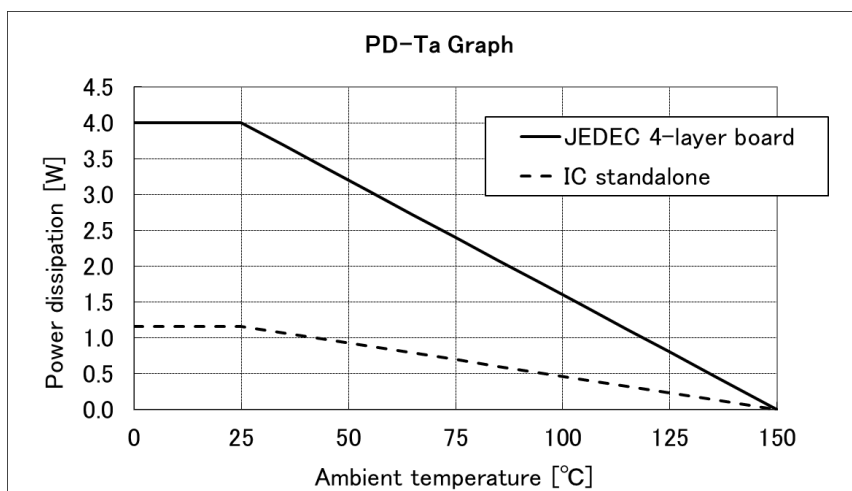

Figure16 PD-Ta graph

17. Operating range ($T_a = -40$ to 85 °C)

Table17 Operating range

Entry	Symbol	Min	Typ.	Max	Unit	Note
Motor power supply voltage (Note 1)	V_M	8.2	24.0	44	V	-
Motor output current	I_{OUT}	-	-	2.7	A	Equivalent to 1 (Note 2)
Logic input voltage	$V_{IN(H)}$	2.0	-	5.5	V	H level of logic
	$V_{IN(L)}$	-0.5	-	0.8	V	L level of logic
Chopping frequency	f_{CHOP}	40	70	150	kHz	-
Clock frequency	f_{CLK}	-	-	250	kHz	-
Vref reference voltage	V_{REF}	0	-	3.6	V	-

Note 1: The slew rate from 0 V to 10 V at power-on should be 1 ms or more. If you intend to use the product under different conditions, please evaluate the customer's product alone and the system as a whole thoroughly and determine its applicability at your own risk.

Note 2: The maximum current that can actually be used may be limited by the operating environment (operating conditions such as excitation mode and operating time, ambient temperature conditions, and heat generation conditions such as board conditions). Please confirm the maximum current value that can actually be used after thermal calculation under the operating environment.

18. Electrical Specifications

18.1. Electrical Specifications 1 (T_a = 25 °C, V_M = 24 V unless otherwise specified)

Table18.1 Electrical Specifications 1

Entry		Symbol	Measuring conditions	Min	Typ.	Max	Unit
Logic Input Pin Input Voltage	High	V _{IN(H)}	Logic input terminal (Note)	2.0	-	5.5	V
	Low	V _{IN(L)}	Logic input terminal (Note)	-0.5	-	0.8	V
input hysteresis		V _{IN(HYS)}	Logic system input terminal (Note)	-	150	-	mV
Logic Input Pin Input current	High	I _{IN(H)}	Measurement Logic input terminal : 5 V	35	50	75	μA
	Low	I _{IN(L)}	Measurement logic system input terminal: 0 V	-	-	1	μA
LO,MO pin output voltage		V _{OL(MO)}	I _{OL} =5 mA, Output Low	-	0.2	0.5	V
Current Consumption		I _{M1}	Output: Open, in sleep mode	-	0.03	1	μA
		I _{M2}	Output : Open, SLEEP=H,ENABLE=L	-	4.8	5.5	mA
		I _{M3}	Output : Open (2-phase excitation), SLEEP=H, ENABLE=H Chopping frequency 40 kHz	-	7.5	8.2	mA
Motor output leakage current	upper side	I _{OH}	V _M = 44V, V _{OUT} = 0 V	-	-	1	μA
	underside	I _{OL}	V _M = V _{OUT} = 44 V	1	-	-	μA
Output current channel-to-channel error		ΔI _{OUT1}	Output current error between channels I _{OUT} = 1.0 A	-5	0	5	%
Output current setting error		ΔI _{OUT2}	I _{OUT} = 1.0 A	-5	0	5	%
Output Transistor Between drain and source On-resistance (sum of upper and lower)		R _{ON(D-S)}	T _J = 25°C I _{OUT} = 2.0 A	-	0.4	0.52	Ω

Note : V_{IN} voltage is defined as V_{IN(H)} when V_{IN} is added to the measurement terminal and its voltage is increased from 0 V and the motor output terminal voltage changes. When the voltage is lowered and the motor output terminal voltage changes, the V_{IN} voltage is defined as V_{IN(L)}. Furthermore, the difference between V_{IN(H)} and V_{IN(L)} is defined as V_{IN(HYS)}.

18.2. Electrical Specifications 2 ($T_a = 25\text{ }^\circ\text{C}$, $V_M = 24\text{ V}$ unless otherwise specified)**Table18.2 Electrical Characteristics 2**

Entry	Symbol	Measuring conditions	Min	Typ.	Max	Unit
Vref Input Current	I_{REF}	$V_{ref} = 3.6\text{ V}$	-	0	1	μA
Vref Attenuation Ratio	$V_{REF(GAIN)}$	$V_{ref} = 2.0\text{ V}$	-	0.833	-	-
TSD Temperature	T_{JTSD}	-	145	160	175	$^\circ\text{C}$
VM power-on reset voltage	V_{MPOR}	-	3.8	4.0	4.2	V
VM power-on reset hysteresis	$V_{MPOR(HYS)}$	-	-	200	-	mV
Overcurrent detection circuit operating current	I_{SD}	-	3.1	4.5	5.8	A

18.2.1. With respect to back EMF

Power regeneration timing occurs while the motor is running, at which time the motor current is regenerated to the power supply due to the back EMF of the motor.

If the power supply does not have Sink capability, the power supply and output terminals of the IC may rise above their ratings.

Since the back EMF of the motor varies depending on the conditions of use and the characteristics of the motor, please make sure that the back EMF does not destroy the IC, that there are no problems with its operation, and that there is no malfunction or destruction of the peripheral circuits, etc.

18.2.2. Overcurrent and overheat detection

These detection functions are intended to temporarily avoid abnormal conditions such as output short circuits, and are not intended to guarantee that the IC will not be destroyed.

The detection function does not work outside the guaranteed operating range, and a short-circuit may destroy the IC.

The overcurrent detection function is intended to detect temporary short circuits. If the short-circuit continues for a long period of time, the IC may be destroyed due to overstress. The system should be configured to release the overcurrent condition as soon as possible.

18.2.3. Handling of ICs

Do not incorrectly install the device, including rotating it, as this may cause destruction, damage, or deterioration to the IC or device.

19. AC electrical characteristics (T_a = 25 °C, V_M = 24V)

Table19 AC electrical characteristics

Entry	Symbol	Measuring conditions	Min	Typ.	Max	Unit
Minimum clock pulse width	t _{CLK(H)}	-	600	-	-	ns
	t _{CLK(L)}	-	600	-	-	ns
Logic Input Signal Minimum Pulse Width 1	t _{RS(H)}	RESET, SLEEP_X, DECAY	1.5	-	-	μs
	t _{RS(L)}	RESET, SLEEP_X, DECAY	1.5	-	-	μs
Logic input signal minimum pulse width 2	t _{DTE(H)}	TRQ0/1, ENABLE	600	-	-	ns
	t _{DTE(L)}	TRQ0/1, ENABLE	600	-	-	ns
Setup time	t _{SU(STEP)}	CW_CCW, DMODE0/1/2	600	-	-	ns
Hold time	t _{H(STEP)}	CW_CCW, DMODE0/1/2	600	-	-	ns
Output Transistor Switching characteristics	t _r	-	40	70	100	ns
	t _f	-	50	80	110	ns
	t _{pLH(CLK)}	-	-	1000	-	ns
	t _{pHL(CLK)}	-	-	1000	-	ns
OSCM oscillation frequency	f _{OSCM1}	R _{osc} =47 kΩ	1020	1200	1380	kHz
	f _{OSCM2}	When OSCM pin is open or GND is short	777	914	1051	
chopping frequency	f _{CHOP}	f _{OSCM} = 1200 kHz	-	75	-	kHz

20. AC Characteristics Timing Chart

TB67S589FNG(Relationship between CLK and output)

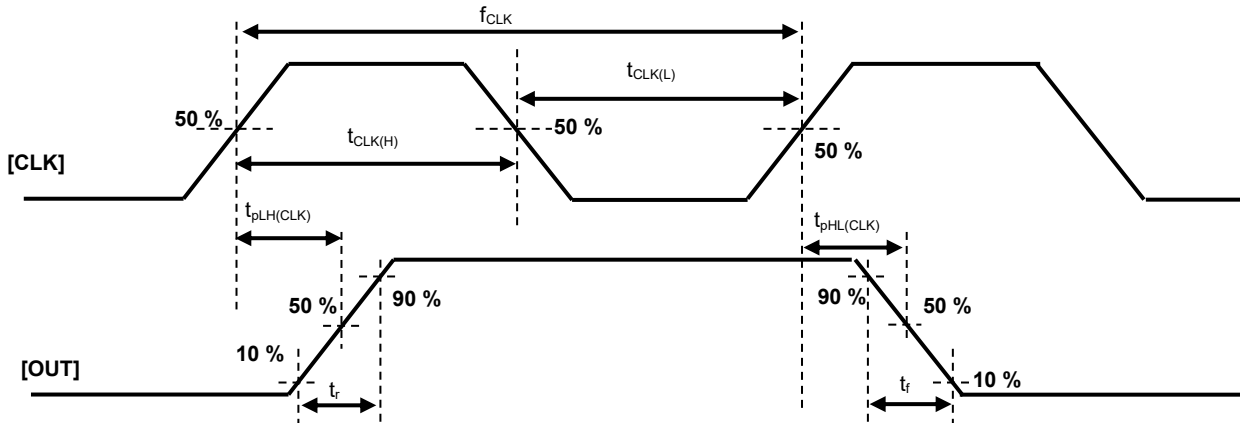

Figure20.1 TB67S589FNG(Relationship between CLK and output)

Note: The timing chart is simplified to explain the function and operation.

TB67S589FNG(Relationship between CLK and other control signals)

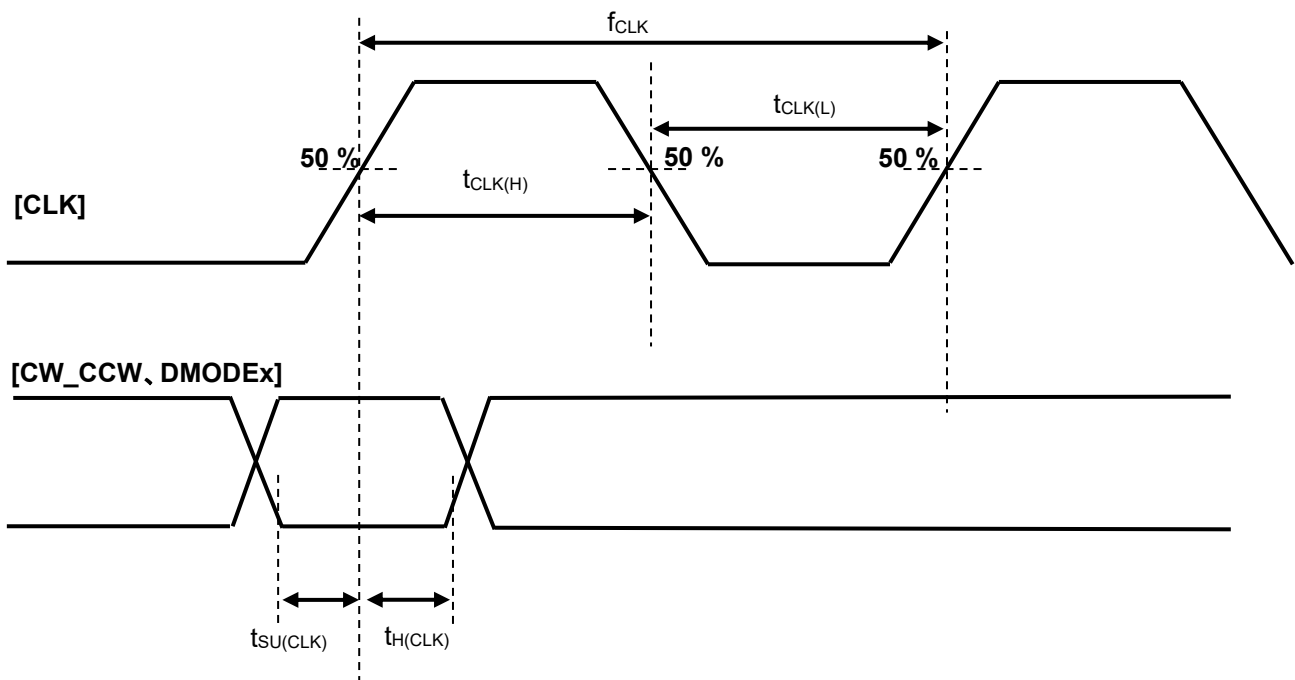

Figure20.2 TB67S589FNG(Relationship between CLK and other control signals)

Note: The timing chart is simplified to explain the function and operation.

21. Application Circuit Example

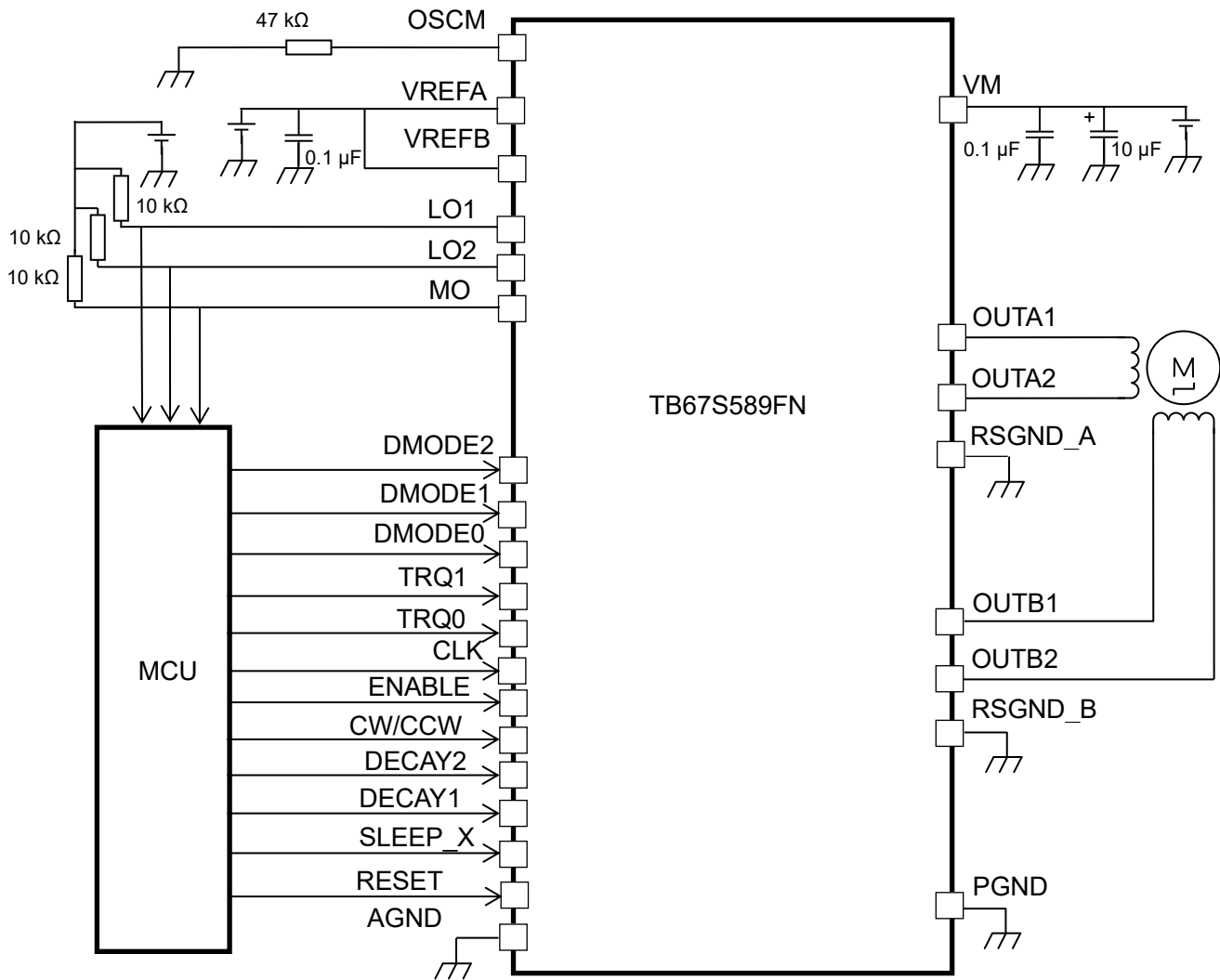

Figure21 Application Circuit Example

It is recommended that the heat dissipation pads (at the four corners and the center) on the backside of the package be connected to the GND of the board to improve heat dissipation.

Note: Some application circuit examples may be omitted or simplified in order to explain the circuit.

22. Package Information

P-HTSSOP28-0510-0.65-001

Unit: mm

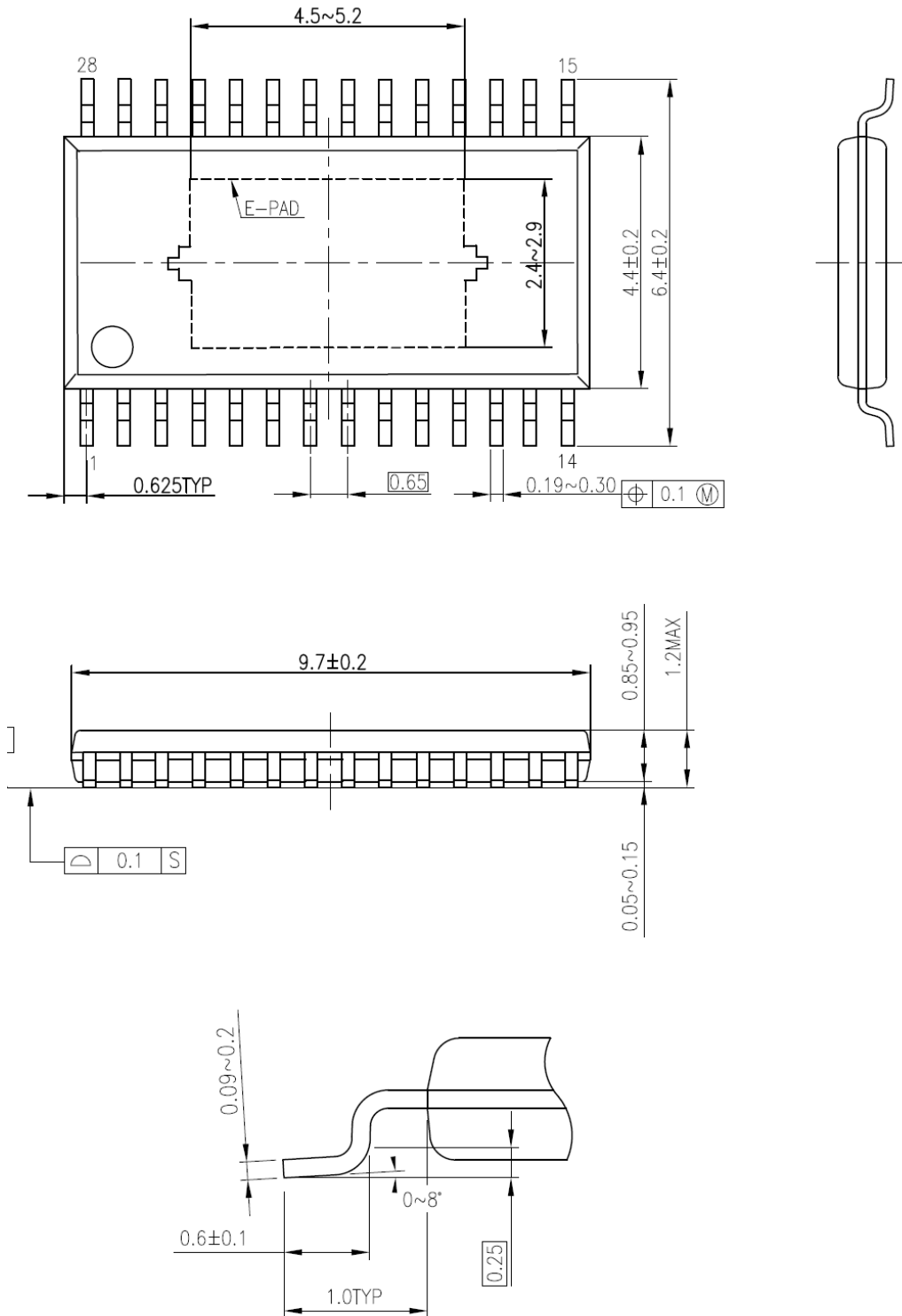

Figure22 Package Dimensions

Weight: 0.106 g (Typ.)

23. Notes on Contents

Block Diagrams

Some of the functional blocks, circuits, or constants in the block diagram may be omitted or simplified for explanatory purposes.

Timing Charts

Timing charts may be simplified for explanatory purposes.

Application Circuits

The application circuits shown in this document are provided for reference purposes only. Thorough evaluation is required, especially at the mass production design stage. Providing these application circuit examples does not grant a license for industrial property rights.

24. IC Usage Considerations

24.1. Notes on Handling of ICs

- (1) The absolute maximum ratings of a semiconductor device are a set of ratings that must not be exceeded, even for a moment. Do not exceed any of these ratings. Exceeding the rating(s) may cause the device breakdown, damage or deterioration, and may result injury by explosion or combustion.
- (2) Use an appropriate power supply fuse to ensure that a large current does not continuously flow in case of over current and/or IC failure. The IC will fully break down when used under conditions that exceed its absolute maximum ratings, when the wiring is routed improperly or when an abnormal pulse noise occurs from the wiring or load, causing a large current to continuously flow and the breakdown can lead smoke or ignition. To minimize the effects of the flow of a large current in case of breakdown, appropriate settings, such as fuse capacity, fusing time and insertion circuit location, are required.
- (3) If your design includes an inductive load such as a motor coil, incorporate a protection circuit into the design to prevent device malfunction or breakdown caused by the current resulting from the inrush current at power ON or the negative current resulting from the back electromotive force at power OFF. IC breakdown may cause injury, smoke or ignition. Use a stable power supply with ICs with built-in protection functions. If the power supply is unstable, the protection function may not operate, causing IC breakdown. IC breakdown may cause injury, smoke or ignition.
- (4) Do not insert devices in the wrong orientation or incorrectly. Make sure that the positive and negative terminals of power supplies are connected properly. Otherwise, the current or power consumption may exceed the absolute maximum rating, and exceeding the rating(s) may cause the device breakdown, damage or deterioration, and may result injury by explosion or combustion. In addition, do not use any device that is applied the current with inserting in the wrong orientation or incorrectly even just one time.
- (5) Carefully select external components (such as inputs and negative feedback capacitors) and load components (such as speakers), for example, power amp and regulator. If there is a large amount of leakage current such as from input or negative feedback condenser, the IC output DC voltage will increase. If this output voltage is connected to a speaker with low input withstand voltage, overcurrent or IC failure may cause smoke or ignition. (The overcurrent may cause smoke or ignition from the IC itself.) In particular, please pay attention when using a Bridge Tied Load (BTL) connection-type IC that inputs output DC voltage to a speaker directly.

24.2. Points to Remember on Handling of ICs

(1) Over current Protection Circuit

Over current protection circuits (referred to as current limiter circuits) do not necessarily protect ICs under all circumstances. If the Over current protection circuits operate against the over current, clear the over current status immediately.

Depending on the method of use and usage conditions, such as exceeding absolute maximum ratings can cause the over current protection circuit to not operate properly or IC breakdown before operation. In addition, depending on the method of use and usage conditions, if over current continues to flow for a long time after operation, the IC may generate heat resulting in breakdown.

(2) Thermal Shutdown Circuit

Thermal shutdown circuits do not necessarily protect ICs under all circumstances. If the thermal shutdown circuits operate against the over temperature, clear the heat generation status immediately. Depending on the method of use and usage conditions, such as exceeding absolute maximum ratings can cause the thermal shutdown circuit to not operate properly or IC breakdown before operation.

(3) Heat Radiation Design

In using an IC with large current flow such as power amp, regulator or driver, please design the device so that heat is appropriately radiated, not to exceed the specified junction temperature (T_j) at any time and condition. These ICs generate heat even during normal use. An inadequate IC heat radiation design can lead to decrease in IC life, deterioration of IC characteristics or IC breakdown. In addition, please design the device taking into consideration the effect of IC heat radiation with peripheral components.

(4) Back-EMF

When a motor reverses the rotation direction, stops or slows down abruptly, a current flow back to the motor's power supply due to the effect of back-EMF. If the current sink capability of the power supply is small, the device's motor power supply and output pins might be exposed to conditions beyond absolute maximum ratings. To avoid this problem, take the effect of back-EMF into consideration in system design.

RESTRICTIONS ON PRODUCT USE

- Toshiba Corporation and its subsidiaries and affiliates are collectively referred to as "TOSHIBA". Hardware, software and systems described in this document are collectively referred to as "Product".
- TOSHIBA reserves the right to make changes to the information in this document and related Product without notice.
- This document and any information herein may not be reproduced without prior written permission from TOSHIBA. Even with TOSHIBA's written permission, reproduction is permissible only if reproduction is without alteration/omission.
- Though TOSHIBA works continually to improve Product's quality and reliability, Product can malfunction or fail. Customers are responsible for complying with safety standards and for providing adequate designs and safeguards for their hardware, software and systems which minimize risk and avoid situations in which a malfunction or failure of Product could cause loss of human life, bodily injury or damage to property, including data loss or corruption. Before customers use the Product, create designs including the Product, or incorporate the Product into their own applications, customers must also refer to and comply with (a) the latest versions of all relevant TOSHIBA information, including without limitation, this document, the specifications, the data sheets and application notes for Product and the precautions and conditions set forth in the "TOSHIBA Semiconductor Reliability Handbook" and (b) the instructions for the application with which the Product will be used with or for. Customers are solely responsible for all aspects of their own product design or applications, including but not limited to (a) determining the appropriateness of the use of this Product in such design or applications; (b) evaluating and determining the applicability of any information contained in this document, or in charts, diagrams, programs, algorithms, sample application circuits, or any other referenced documents; and (c) validating all operating parameters for such designs and applications. **TOSHIBA ASSUMES NO LIABILITY FOR CUSTOMERS' PRODUCT DESIGN OR APPLICATIONS.**
- **PRODUCT IS NEITHER INTENDED NOR WARRANTED FOR USE IN EQUIPMENTS OR SYSTEMS THAT REQUIRE EXTRAORDINARILY HIGH LEVELS OF QUALITY AND/OR RELIABILITY, AND/OR A MALFUNCTION OR FAILURE OF WHICH MAY CAUSE LOSS OF HUMAN LIFE, BODILY INJURY, SERIOUS PROPERTY DAMAGE AND/OR SERIOUS PUBLIC IMPACT ("UNINTENDED USE").** Except for specific applications as expressly stated in this document, Unintended Use includes, without limitation, equipment used in nuclear facilities, equipment used in the aerospace industry, lifesaving and/or life supporting medical equipment, equipment used for automobiles, trains, ships and other transportation, traffic signaling equipment, equipment used to control combustions or explosions, safety devices, elevators and escalators, and devices related to power plant. **IF YOU USE PRODUCT FOR UNINTENDED USE, TOSHIBA ASSUMES NO LIABILITY FOR PRODUCT.** For details, please contact your TOSHIBA sales representative or contact us via our website.
- Do not disassemble, analyze, reverse-engineer, alter, modify, translate or copy Product, whether in whole or in part.
- Product shall not be used for or incorporated into any products or systems whose manufacture, use, or sale is prohibited under any applicable laws or regulations.
- The information contained herein is presented only as guidance for Product use. No responsibility is assumed by TOSHIBA for any infringement of patents or any other intellectual property rights of third parties that may result from the use of Product. No license to any intellectual property right is granted by this document, whether express or implied, by estoppel or otherwise.
- **ABSENT A WRITTEN SIGNED AGREEMENT, EXCEPT AS PROVIDED IN THE RELEVANT TERMS AND CONDITIONS OF SALE FOR PRODUCT, AND TO THE MAXIMUM EXTENT ALLOWABLE BY LAW, TOSHIBA (1) ASSUMES NO LIABILITY WHATSOEVER, INCLUDING WITHOUT LIMITATION, INDIRECT, CONSEQUENTIAL, SPECIAL, OR INCIDENTAL DAMAGES OR LOSS, INCLUDING WITHOUT LIMITATION, LOSS OF PROFITS, LOSS OF OPPORTUNITIES, BUSINESS INTERRUPTION AND LOSS OF DATA, AND (2) DISCLAIMS ANY AND ALL EXPRESS OR IMPLIED WARRANTIES AND CONDITIONS RELATED TO SALE, USE OF PRODUCT, OR INFORMATION, INCLUDING WARRANTIES OR CONDITIONS OF MERCHANTABILITY, FITNESS FOR A PARTICULAR PURPOSE, ACCURACY OF INFORMATION, OR NONINFRINGEMENT.**
- Do not use or otherwise make available Product or related software or technology for any military purposes, including without limitation, for the design, development, use, stockpiling or manufacturing of nuclear, chemical, or biological weapons or missile technology products (mass destruction weapons). Product and related software and technology may be controlled under the applicable export laws and regulations including, without limitation, the Japanese Foreign Exchange and Foreign Trade Law and the U.S. Export Administration Regulations. Export and re-export of Product or related software or technology are strictly prohibited except in compliance with all applicable export laws and regulations.
- Please contact your TOSHIBA sales representative for details as to environmental matters such as the RoHS compatibility of Product. Please use Product in compliance with all applicable laws and regulations that regulate the inclusion or use of controlled substances, including without limitation, the EU RoHS Directive. **TOSHIBA ASSUMES NO LIABILITY FOR DAMAGES OR LOSSES OCCURRING AS A RESULT OF NONCOMPLIANCE WITH APPLICABLE LAWS AND REGULATIONS.**