



# FAIRCHILD • TBA8105/TBA810AS/TBA810DS/TBA810DAS

**ELECTRICAL CHARACTERISTICS:** Refer to the test circuit:  $T_A = 25^\circ\text{C}$

CHARACTERISTICS	TEST CONDITIONS	MIN	TYP	MAX	UNITS
Quiescent Output Voltage (Pin 12)	$V_+ = 14.4\text{ V}$	6.4	7.2	8.0	V
Quiescent Drain Current (Pin 1)			12	20	mA
Bias Current (Pin 8)				0.4	$\mu\text{A}$
Power Output	THD = 10%, $R_L = 4.0\ \Omega$ , $f = 1.0\text{ kHz}$ $V_+ = 16\text{ V}$		7.0		W
	$V_+ = 14.4\text{ V}$		6.0		W
	$V_+ = 9.0\text{ V}$		2.5		W
	$V_+ = 6.0\text{ V}$		1.0		W
Input Sensitivity	$P_{OUT} = 6\text{ W}$ , $V_+ = 14.4\text{ V}$ , $R_L = 4.0\ \Omega$ , $f = 1.0\text{ kHz}$				
	$R_f = 56\ \Omega$		80		mV
	$R_f = 22\ \Omega$		35		mV
Input Resistance (Pin 8)			5.0		M $\Omega$
Frequency Response (-3.0 dB)	$V_+ = 14.4\text{ V}$ , $R_L = 4.0\ \Omega$ $C_3 = 820\ \text{pF}$		40 to 20,000		Hz
	$C_3 = 1500\ \text{pF}$		40 to 10,000		Hz
Total Harmonic Distortion	$P_{OUT} = 50\text{ mW}$ to 3 W, $V_+ = 14.4\text{ V}$ $R_L = 4.0\ \Omega$ , $f = 1.0\text{ kHz}$		0.3		%
Voltage Gain (Open Loop)	$V_+ = 14.4\text{ V}$ , $R_L = 4.0\ \Omega$ , $f = 1.0\text{ kHz}$		80		dB
Voltage Gain (Closed Loop)	$V_+ = 14.4\text{ V}$ , $R_L = 4.0\ \Omega$ , $f = 1.0\text{ kHz}$	34	37	40	dB
Input Noise Voltage	$V_+ = 14.4\text{ V}$ , $R_g = 0$ , $BW(-3.0\text{ dB}) = 20\text{ Hz}$ to 20,000 Hz		2.0		$\mu\text{V}$
Input Noise Current	$V_+ = 14.4\text{ V}$ , $BW(-3.0\text{ dB}) = 20\text{ Hz}$ to 20,000 Hz		0.1		nA
Efficiency	$P_{OUT} = 5\text{ W}$ , $V_+ = 14.4\text{ V}$ , $R_L = 4.0\ \Omega$ , $f = 1.0\text{ kHz}$		70		%
Supply Voltage Rejection	$V_+ = 14.4\text{ V}$ , $R_L = 4.0\ \Omega$ , $f_{\text{ripple}} = 100\text{ Hz}$		38		dB

**THERMAL DATA**

$\theta_{JC}$  Thermal Resistance Junction to Case (tab)  
 $\theta_{JA}$  Thermal Resistance Junction to Ambient

**TBA810S/DS**

12° C/W  
 70° C/W\*\*

**TBA810AS/DAS**

10° C/W  
 80° C/W

\*\* Obtained with tabs soldered to printed circuit with minimized copper area.

**TEST AND APPLICATION CIRCUIT**

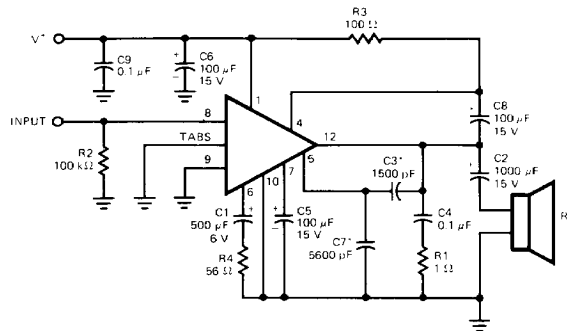

\*C3, C7 See Fig. 6

TYPICAL PERFORMANCE CURVES FOR TBA810S/TBA810AS/TBA810DS/TBA810DAS

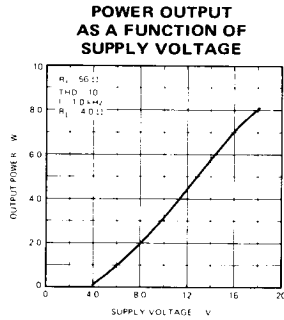

Fig. 1

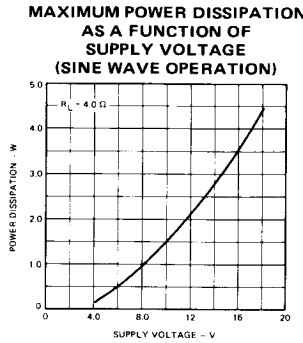

Fig. 2

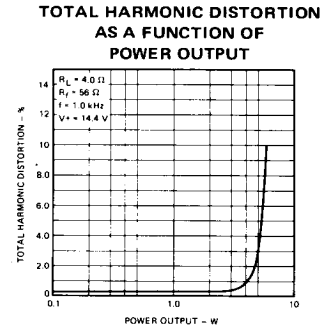

Fig. 3

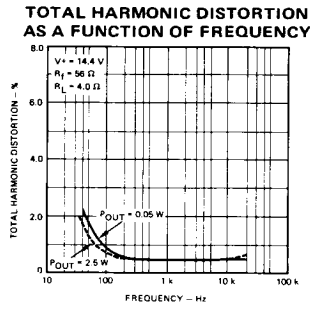

Fig. 4

TYPICAL RELATIVE VOLTAGE GAIN (CLOSED LOOP) AND TYPICAL INPUT VOLTAGE AS A FUNCTION OF FEEDBACK RESISTANCE ( $R_f$ )

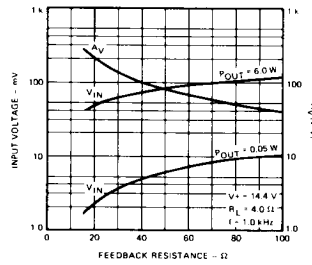

Fig. 5

TYPICAL VALUE OF  $C_3$  AS A FUNCTION OF  $R_f$  FOR VARIOUS VALUES OF BANDWIDTH

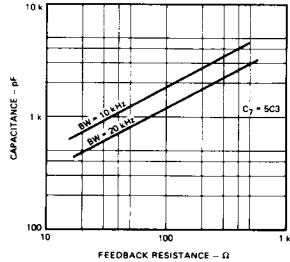

Fig. 6

TYPICAL POWER DISSIPATION AND EFFICIENCY AS A FUNCTION OF POWER OUTPUT

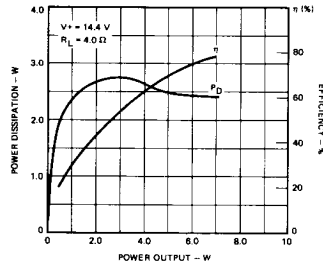

Fig. 7

TYPICAL PERFORMANCE CURVES FOR TBA810S/TBA810AS/TBA810DS/TBA810DAS (Cont'd)

TYPICAL QUIESCENT OUTPUT VOLTAGE (PIN 12) AS A FUNCTION OF SUPPLY VOLTAGE

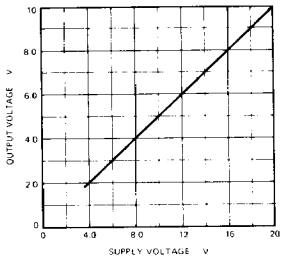

Fig. 8

TYPICAL QUIESCENT CURRENT AS A FUNCTION OF SUPPLY VOLTAGE

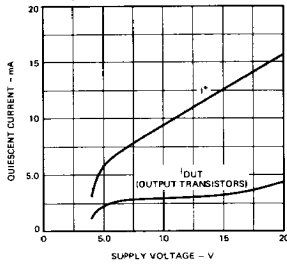

Fig. 9

TYPICAL SUPPLY VOLTAGE REJECTION AS A FUNCTION OF FEEDBACK RESISTANCE

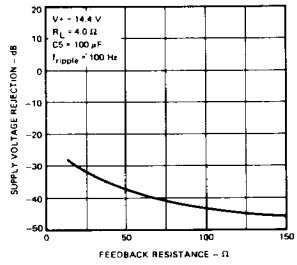

Fig. 10

TYPICAL CIRCUIT WITH LOAD CONNECTED TO THE SUPPLY VOLTAGE

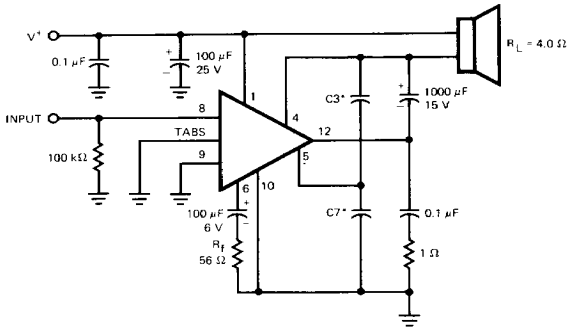

Fig. 11

\*C3, C7 see Fig. 6.

TYPICAL SUPPLY VOLTAGE REJECTION AS A FUNCTION OF R<sub>f</sub> (FIG. 11 CIRCUIT)

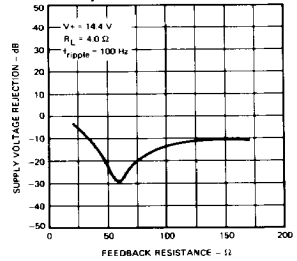

Fig. 12

MOUNTING INSTRUCTIONS

The thermal power dissipated in the circuit may be removed by connecting the tabs to an external heat sink (TBA810AS/TBA810DAS, Figure 13) or by soldering them to an area of copper on the printed circuit. (TBA810S/TBA810DS, Figure 14). During soldering, the tabs temperature must not exceed 230°C and the soldering time must not be longer than 12 seconds. Figures 15a and 15b show two ways that can be used for mounting the device.

MAXIMUM POWER DISSIPATION AS A FUNCTION OF AMBIENT TEMPERATURE (TBA810AS AND TBA810DAS)

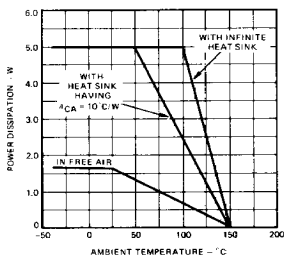

Fig. 13

MAXIMUM POWER DISSIPATION AND TOTAL THERMAL RESISTANCE  
AS A FUNCTION OF COPPER AREA OF PC BOARD  
(TBA810S AND TBA810DS)

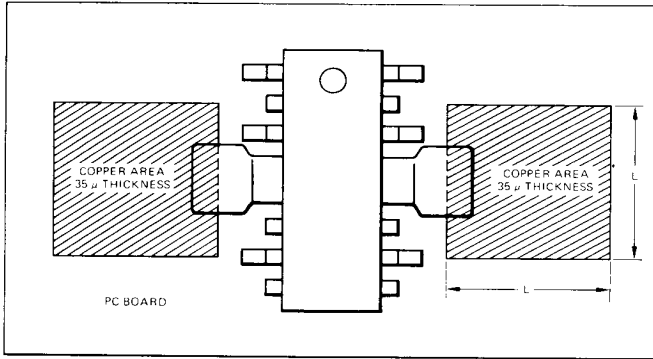

Fig. 14

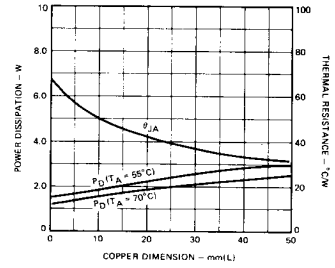

Figure 15a shows a method of mounting the TBA810S or TBA810DS that is satisfactory both from the point of view of heat dissipation and from mechanical considerations. For the TBA810AS and the TBA810DAS, the desired thermal resistance is obtained attaching the hardware shown in Figure 15b, to a bracket with proper dimensions. This bracket can also act as a support for the whole printed circuit board.

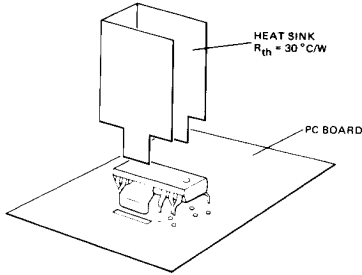

Fig. 15a

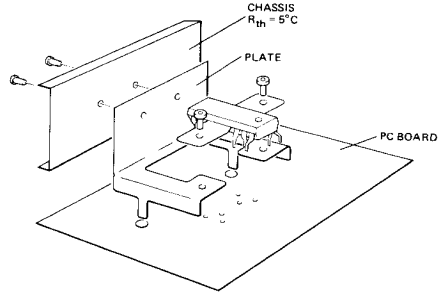

Fig. 15b

**THERMAL SHUTDOWN**

The on chip design of the thermal limiting circuit offers the following advantages:

1. An overload on the output (even if permanent) or an above-limit ambient temperature can be easily handled.
2. The heat sink can have a smaller factor of safety compared with that of a conventional circuit. In case of too high a junction temperature, power output, power dissipation and the supply current decrease (Figure 16) thus protecting the device.

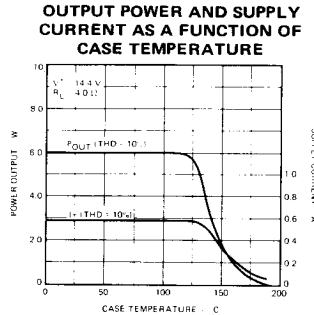

Fig. 16