

TFT LCD Specification

Model Name: TC015TREA1

Confirmed by	Checked by	Prepared by
Date	Date	Date

This technical specification is subjected to change without notice

Table of Contents

NO.	Item	Page
	Cover Sheet	1
	Table of Contents	2
	Record of Reversion	3
1	Features	4
2	General Specification	4
3	Input / Output Terminals	5
4	Absolute Maximum Ratings	6
5	Electrical Characteristics	7
6	Timing Chart	8
7	Optical Characteristics	10
8	Reliability	13
9	Handling Cautions	14
10	Mechanical Drawing	15
11	Packing Drawing	16

1. FEATURES

The 1.5"(3.86 cm) LCD module is the active matrix color TFT LCD module. LTPS (Low Temperature Poly Silicon) TFT technology is used and vertical and horizontal drivers are built on the panel. NTSC and PAL format are compatible. Horizontal scan can be from left to right or from right to left and Vertical scan can be from up to down or from down to up.

2. GENERAL SPECIFICATIONS

Item	Description	Unit
Display Size (Diagonal)	1.5 inch (3.86cm)	
Display Type	Transmissive	
Active Area (HxV)	31.15 X 22.80	mm
Number of Dots (HxV)	490 x 240=117,600	dot
Dot Pitch (HxV)	0.0635 X 0.095	mm
Color Arrangement	RGB Delta	
Color Numbers	Full Color	
Outline Dimension (HxVxT)	37.1 x 32.7 x 3.74	mm
Weight	10	g
Surface Treatment	Anti Reflection	

* Exclude FPC and protrusions.

3. INPUT/OUTPUT TERMINALS

3.1 TFT LCD Panel

Recommend Connector Type: HIROSE FH24S-0.5SH

Pin	Symbol	I/O	Description	Remark
1	NC	-	No connection (Leave this pin open)	
2	COM	I	Common voltage	
3	CKV1	I	Vertical clock 1	
4	CKV2	I	Vertical clock 2	
5	VVDD	I	Power supply for vertical driver	
6	STV	I	Vertical start signal	
7	XSTV	I	Inverted signal of STV	
8	CSV	I	Up / Down inverse control signal	Note 3-1
9	ENB	I	Enable signal	
10	XENB	I	Inverted signal of ENB	
11	PCD	I	Precharge data signal	
12	B	I	Video signal (B)	
13	R	I	Video signal (R)	
14	G	I	Video signal (G)	
15	VSS	I	VSS for vertical and horizontal driver	
16	XPCG	I	Inverted signal of PCG	
17	PCG	I	Precharge gate signal	
18	CSH	I	Right / Left inverse control signal	Note 3-2
19	XSTH	I	Inverted signal of STH	
20	STH	I	Horizontal start signal	
21	CKH2	I	Horizontal clock 2	
22	CKH1	I	Horizontal clock 1	
23	HVDD	I	Power supply for horizontal driver	
24	NC	-	No connection (Leave this pin open)	

Note 3-1: H: Normal scan,

L: Reverse scan

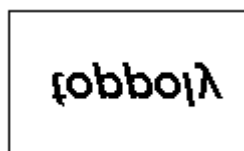

Note 3-2: H: Normal scan,

L: Reverse scan

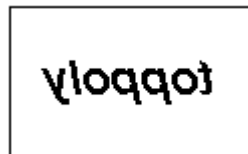

3.2 Light Source

Light Source Type: LED Backlight

Recommend Connector Type: JST-ZHR-2

Pin	Symbol	Description	Remark
1	V _F	LED Input Voltage	
2	V _{FS}	GND for LED Backlight	

4. ABSOLUTE MAXIMUM RATINGS

VSS=0V

Item	Symbol	MIN	MAX	Unit
Power Supply for Horizontal Driver	HVDD	-1.0	+14	V
Power Supply for Vertical Driver	VVDD	-1.0	+14	V
Common Electrode Voltage	VCOM	-1.0	+14	V
Horizontal Driver / Precharge Data Input Voltage	STH, XSTH, CKH1, CKH2, CSH, PCG, XPCG	-1.0	+14	V
Vertical Driver / Precharge Data Input Voltage	STV, XSTV, CKV1, CKV2, CSV, ENB, XENB	-1.0	+14	V
Video / Precharge Data Input Voltage	VG, VR, VB, VPCD	-1.0	+13	V
Back Light Forward Current	I _F	-	25	mA
Operating Temperature	Topr	-10	+60	°C
Storage Temperature	Tstg	-30	+80	°C

5. ELECTRICAL CHARACTERISTICS

5.1 Driving TFT LCD Panel

VSS=0V, Ta=25°C

Item	Symbol	MIN	TYP	MAX	Unit	Remark
Power Supply for Vertical Driver	VVDD	11.7	12	12.3	V	
Power Supply for Horizontal Driver	HVDD	11.7	12	12.3	V	
Horizontal Driver Input Voltage	Low	VHIL	-0.3	0.0	0.3	V
	High	VHIH	2.5	3.0	4.0	V
Vertical Driver Input Voltage	Low	VVIL	-0.3	0.0	0.3	V
	High	VVIH	2.5	3.0	4.0	V
CSH, CSV	Low	VSIL	-0.3	0.0	0.3	V
	High	VSIH	11.5	VDD	VDD	V
Video Signal Center Voltage	VVC	5.0	5.2	5.4	V	Note 5-1
Video Input Voltage Range	VG, VR, VB	VCC-3.5	--	VVC+3.5	V	
Common Electrode Voltage	VCOM	--	VVC-0.2	--	V	Note 5-2
Current of Vertical Driver	IVDD	--	0.66	--	mA	
Current of Horizontal Driver	IHDD	--	2.9	--	mA	
Panel Power Consumption	W _P	--	43	--	mW	

Note 5-1: Video signal and precharge data signal shall be input symmetrically around VVC.

Note 5-2: Set common electrode voltage to the optimum voltage.

(1) Driving TFT LCD Panel Block Diagram

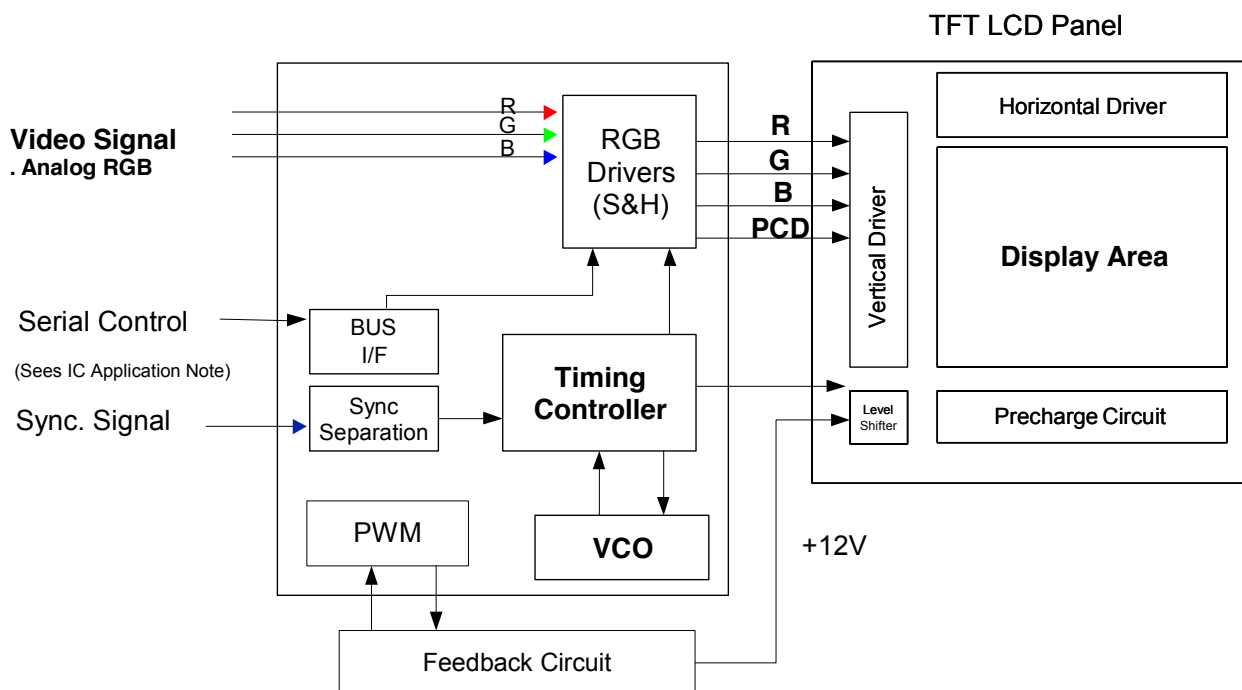

5.2 Driving Backlight

Ta=25°C

Item	Symbol	MIN	TYP	MAX	Unit	Remark
Forward Current	I _F	--	15	20	mA	Note 5-3
Forward Current Voltage	V _F	8.85	10.425	11.625	V	
Backlight Power Consumption	W _{BL}	--	156.375	--	mW	

Note 5-3: Backlight driving circuit is recommend as the fix current circuit.

6. TIMING CHART

6.1 Horizontal

	NTSC Cycle(fh)	PAL Cycle(fh)	1(fh)	2(fh)	3(fh)	4(fh)	5(fh)	6(fh)	7(fh)	8(fh)	9(fh)	10(fh)	11(fh)
Odd Line	622 (t=102.2ns)	636 (t=100.6ns)	82.5	12	6	69	9.5	25	19.5	31.5	76.5	50	32.5
Even Line	622 (t=102.2nS)	636 (t=100.6nS)	81	12	6	69	8	25	18	30	75	50	32.5

(1) Odd Line

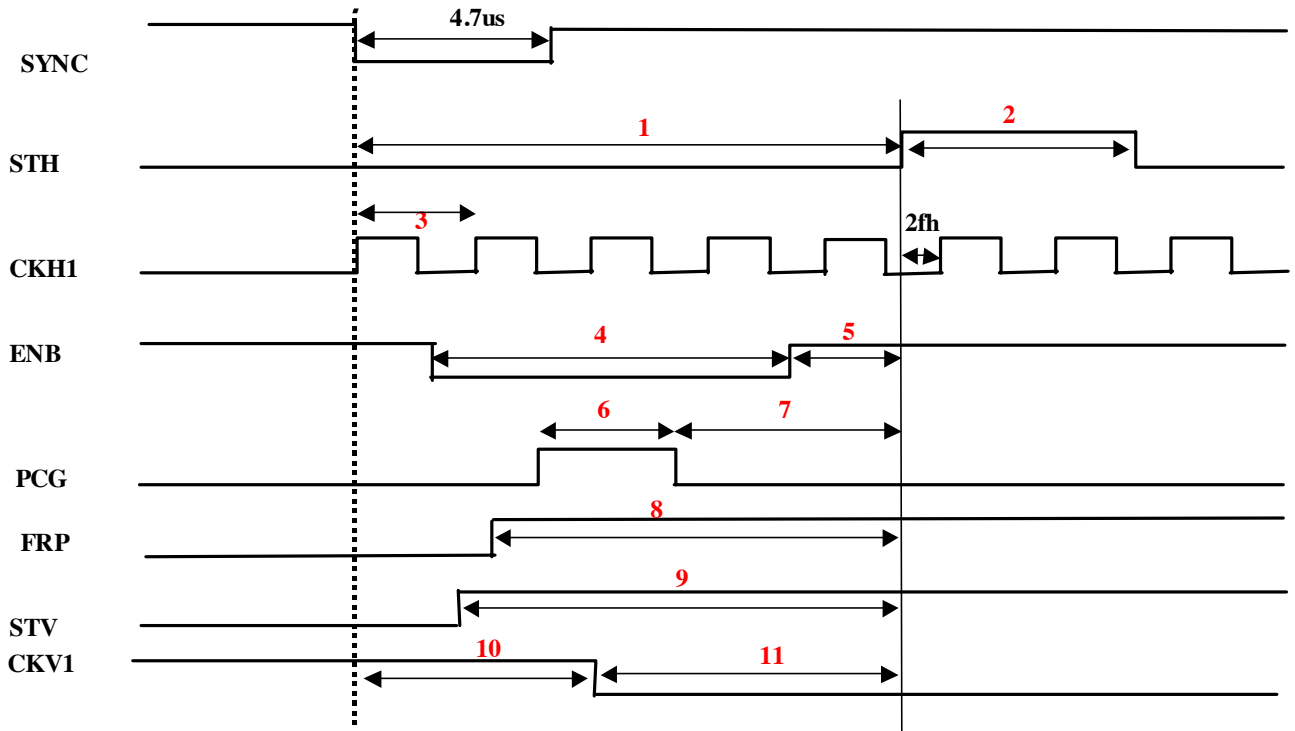

(2) Even Line

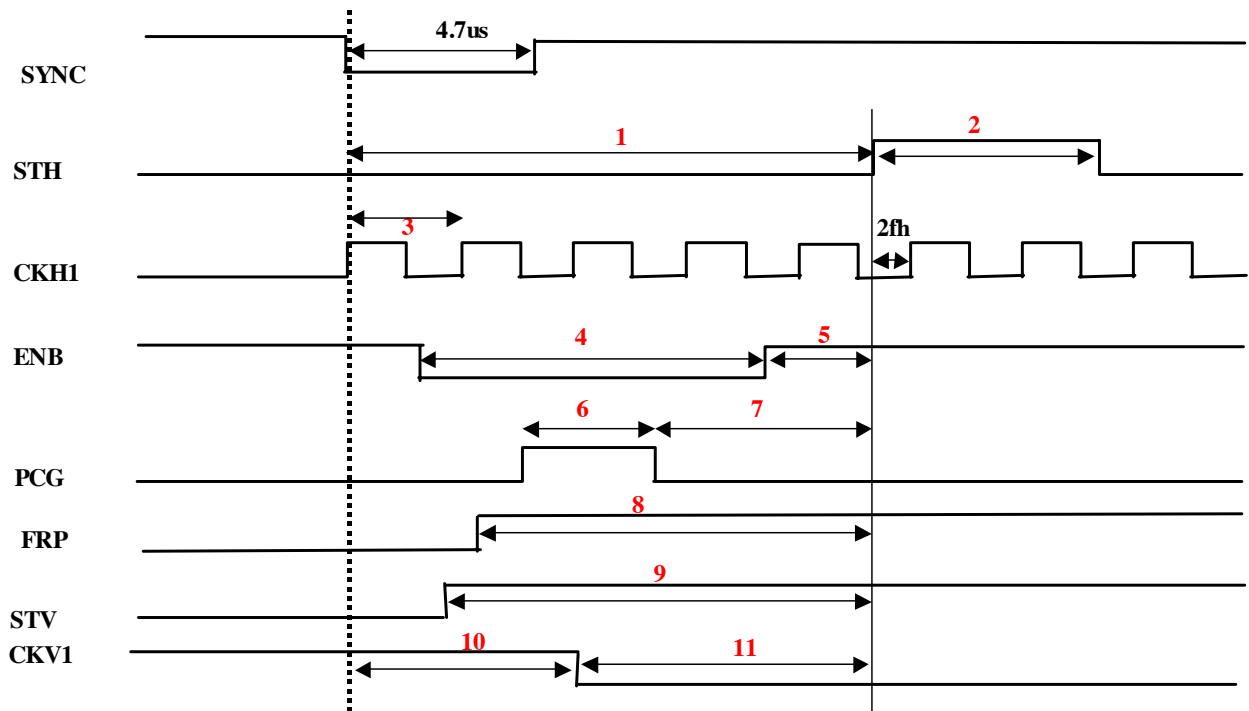

6.2 Vertical

(1) Display Area

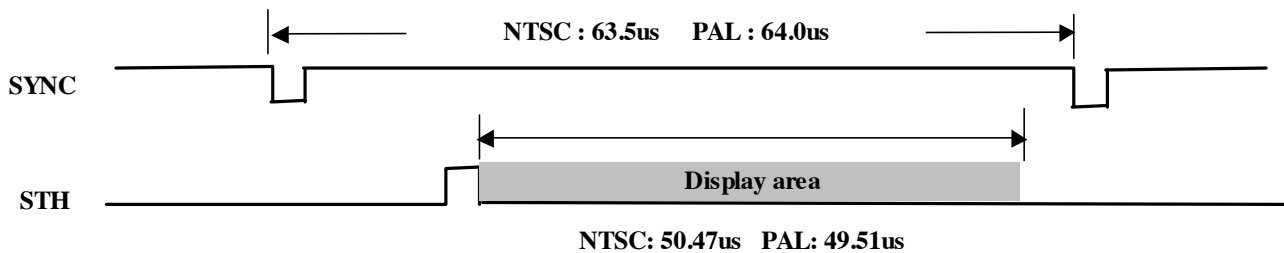

(2) Start Position

	Odd Field	Even Field
NTSC	16	15
PAL	23	22

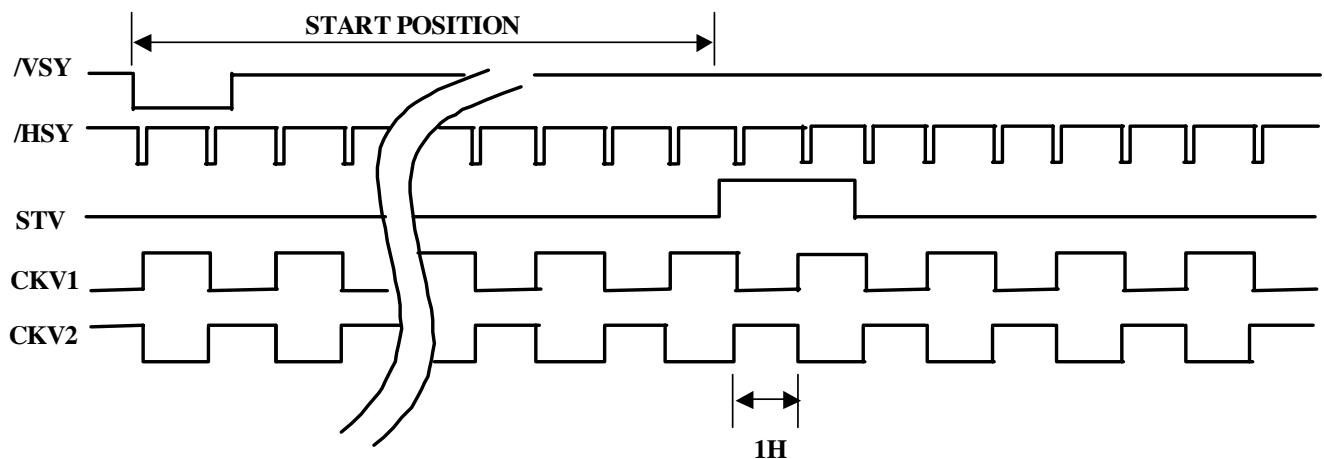

7. OPTICAL CHARACTERISTICS

7.1 Optical Specification

Ta=25°C

Item	Symbol	Condition	MIN	TYP	MAX	Unit	Remarks
Viewing Angles	Θ11	CR ≥ 10	35	40	--	Degree	Note 7-1
	Θ12		35	40	--		
	Θ21		15	20	--		
	Θ22		50	60	--		
Contrast Ratio	CR	Θ=0°	100	150	--		Note 7-2
Response Time	Rising	Tr	--	17	--	ms	Note 7-3
	Falling	Tf	--	30	--		
Luminance (I _F =15mA)	L		220	260	--	cd/m ²	Note 7-5
V-T Characteristics	V90	VT90	--	2.3	--	V	Note 7-4
	V10	VT10	--	1.4	--	V	
Chromaticity	White	x _w	--	0.295	0.325		Note 7-6
		y _w	--	0.310	0.360		

7.2 Basic Measure Condition

- (1) Driving voltage
 HVDD= 12.0V, VVDD=12.0V
 VVC=5.2V, VCOM = Optimum common electrode voltage
- (2) Ambient Temperature: Ta=25°C
- (3) Testing Point: Measure in the display center point and the test angle θ=0°
- (4) R, G, B signal input voltage VG, VR, VB
 VG, VR, VB=VVC ± VAC (VAC: Signal Amplitude)
- (5) LED Current: I_F=15mA.
- (6) Testing Facility: Topcon BM-5A
 Environmental illumination: ≤ 10 Lux

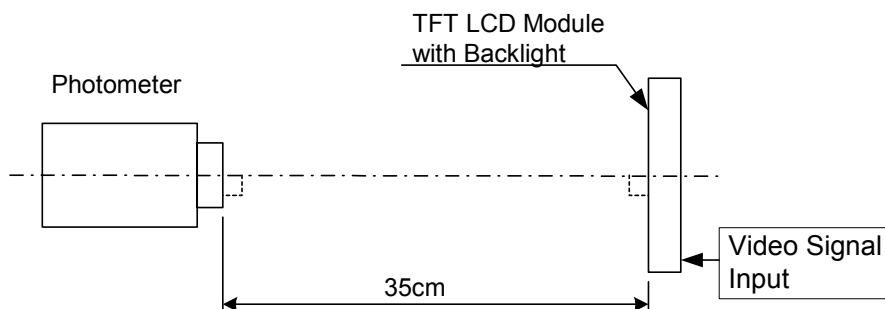

Note 7-1: Viewing angle diagrams:

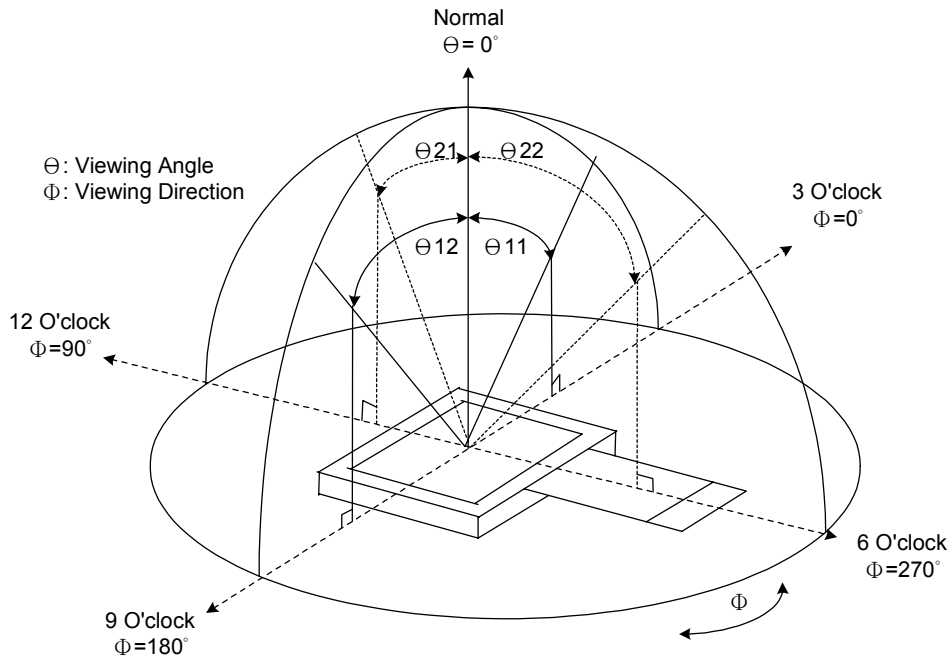

Note 7-2: Contrast Ratio:

Contrast ratio is measured in optimum common electrode voltage. The signal amplitude VAC of white image is 0.5V and black image is 3.5V.

$$CR = \frac{\text{Luminance with white image}}{\text{Luminance with black image}}$$

Note 7-3: Definition of response time:

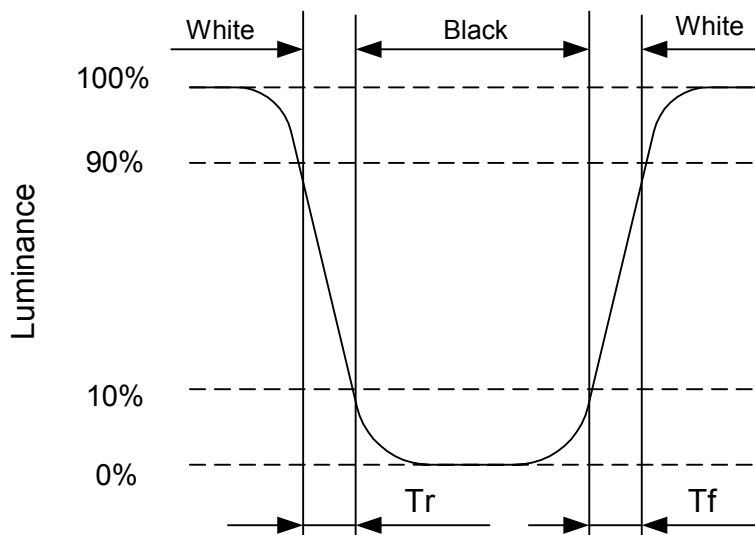

Note 7-4: V-T Characteristics:

Measure the relationship between video signal amplitude and transmittance. Define the voltage of 90% transmittance is V90 and the voltage of 10% transmittance is V10

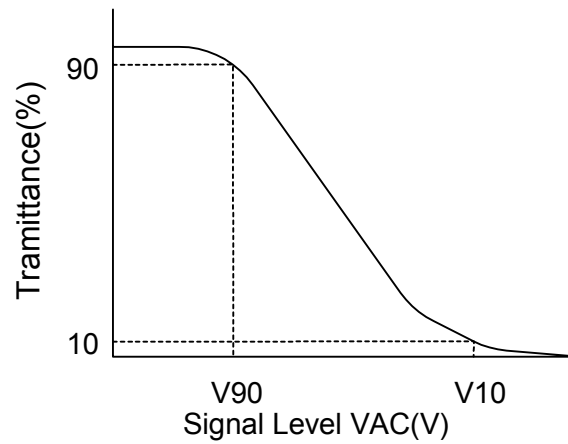

Note 7-5: Luminance:

Test Point: Display Center

Test Circuit: See Section 7.2(5) Testing fix current circuit

Note 7-6: Chromaticity: The same test condition as Note 7-5.

8. REILIABILITY

No	Test Item	Condition
1	High Temperature Operation	Ta=+60°C, 240hrs
2	High Temperature & High Humidity Operation	Ta=+40°C, 95% RH, 240hrs
3	Low Temperature Operation	Ta=-10°C, 240hrs
4	High Temperature Storage (non-operation)	Ta=+80°C, 240hrs
5	Low Temperature Storage (non-operation)	Ta=-30°C, 240hrs
6	Thermal Shock (non-operation)	-30°C ↔ 80°C, 50 cycles 30 min 30 min
7	Resistance to Static Electricity Discharge (non-operation)	C=200pF, R=0Ω; Discharge: ±150V 3 times / Terminal
8	Surface Discharge (non-operation)	C=150pF, R=330Ω; Discharge: Air: ±15kV; Contact: ±8kV 5 times / Point; 5 Points / Panel
9	Vibration (non-operation)	Frequency: 10~55Hz; Amplitude: 1.5mm Sweep Time: 11min Test Time: 2 hrs for each direction of X, Y, Z
10	Shock (non-operation)	Acceleration: 100G; Period: 6ms Directions: ±X, ±Y, ±Z; Cycles: Twice

Ta: Ambient Temperature

9. HANDLING CAUTIONS

9.1 ESD (Electrical Static Discharge) Strategy

ESD will cause serious damage of the panel, ESD strategy is very important in handling. Following items are the recommend ESD strategy

- (1) In handling LCD panel, please wear non-charged material gloves. And the conduction ring connect wrist to the earth and the conducting shoes to the earth is necessary.
- (2) The machine and working table for the panel should have ESD prohibition strategy.
- (3) In handling the panel, ionize flowing decrease the charge in the environment is necessary.
- (4) In the process of assembly the module, shield case should connect to the ground.

9.2 Environment

- (1) Working environment of the panel should in the clean room.
- (2) The front poliazzer is easy damaged, handle it carefully and do not scratch it by sharp material.
- (3) Panel has polarizer protective film in the surface please remove the protection film of polarizer slowly with ionized air to prevent the electrostatic discharge.

9.3 Others

- (1) Turn off the power supply before connecting and disconnecting signal input cable.
- (2) The connection area of FPC and panel is very weak, do not handle panel only by FPC or bend FPC.
- (3) Water drop on the surface or condensation as panel power on will corrode panel electrode.
- (4) As the packing bag open, watch out the environment of the panel storage. High temperature and high humidity environment is prohibited.
- (5) When the TFT LCD module is broken, please watch out whether liquid crystal leaks out or not. If your hand touches liquid crystal, wash your hand cleanly by water and soap as soon as possible.

11. Packing Drawing

