

INSTRUCTION MANUAL



TC041-L Precipitation Sensor **(Precipitation Occurrence & Rainfall Intensity)**

Sept 2008



*Copyright © 2008
Campbell Scientific (Canada) Corp.*

WARRANTY AND ASSISTANCE

This equipment is warranted by CAMPBELL SCIENTIFIC (CANADA) CORP. ("CSC") to be free from defects in materials and workmanship under normal use and service for **twelve (12) months** from date of shipment unless specified otherwise. ***** **Batteries are not warranted.** ***** CSC's obligation under this warranty is limited to repairing or replacing (at CSC's option) defective products. The customer shall assume all costs of removing, reinstalling, and shipping defective products to CSC. CSC will return such products by surface carrier prepaid. This warranty shall not apply to any CSC products which have been subjected to modification, misuse, neglect, accidents of nature, or shipping damage. This warranty is in lieu of all other warranties, expressed or implied, including warranties of merchantability or fitness for a particular purpose. CSC is not liable for special, indirect, incidental, or consequential damages.

Products may not be returned without prior authorization. To obtain a Return Merchandise Authorization (RMA), contact CAMPBELL SCIENTIFIC (CANADA) CORP., at (780) 454-2505. An RMA number will be issued in order to facilitate Repair Personnel in identifying an instrument upon arrival. Please write this number clearly on the outside of the shipping container. Include description of symptoms and all pertinent details.

CAMPBELL SCIENTIFIC (CANADA) CORP. does not accept collect calls.

Non-warranty products returned for repair should be accompanied by a purchase order to cover repair costs.



CAMPBELL SCIENTIFIC
C A N A D A C O R P .

11564 - 149 street - edmonton - alberta - T5M 1W7
tel 780.454.2505 fax 780.454.2655

www.campbellsci.ca

TABLE OF CONTENTS

1. Specifications:.....	2
2. Introduction:.....	2
3. Operation:	3
4. Mounting:.....	4
5. Wiring:	4
6. Program Examples:.....	5
6.1. Event Based Output Program Example	5
7. Maintenance:.....	7

Notes:

- Only open sensor housing in dry conditions, if ever necessary. Moisture contamination may damage internal electronics.
- Power supply installation should follow applicable National and Local electrical codes.

Warnings:

- Do not conduct power supply installation or wiring of power supply with the AC source turned on. Personal injury and equipment damage may occur.

1. Specifications:

Output: 4 – 20 mA constant current (requires the use of CURS100 current shunt to interface with Campbell Scientific datalogger)

Measurement Range (millimeters per minute):

4 – 8 mA: 0 – 0.01 mm/min
8 – 12 mA: 0.01 – 0.1 mm/min
12 – 16 mA: 0.1 – 1 mm/min
16 – 20 mA: 1 – 10 mm/min

The four output ranges represent four linear characteristic segments of rainfall intensity.

Active sensor surface: 25 cm²
Minimum particle size: 0.2 mm
Accuracy (Rainfall only) ± 10% for rainfall intensity

Operating Temperature: -30°C - 60°C

Power Supply:

Operating voltage: 24 V AC/DC ± 15%
Operating current: 90 mA (continuous)
Heating current: 1.0 A (maximum)

Weight: 0.4 Kg
Sensor dimensions: 135mm (length), 125mm (width), 38mm (depth)

Protection: IP 65 acc. To DIN 40050
EMV: EN 61000-6-2, EN 61000-6-3

2. Introduction:

The TC041-L is an effective precipitation occurrence sensor which also serves to measure instantaneous rainfall intensities (i.e. millimeters per minute – mm/min). The precipitation can be in the form of drizzle, rain, snow, or hail. The TC041-L does not differentiate between types of precipitation.

The sensor signal output is an intensity dependent milliampere (mA) value over the range of 4 to 20mA. The current output represents a rainfall intensity range of 0 to 10 mm/min. The use of a current shunt is required in order to interface the sensor with a Campbell Scientific datalogger (i.e. CURS100).

Outputs are divided into four linear characteristic segments. Each segment has a slope that is 10% of the magnitude of the next segment. Figure 1 is a graphical representation of the four rainfall intensity output segments.

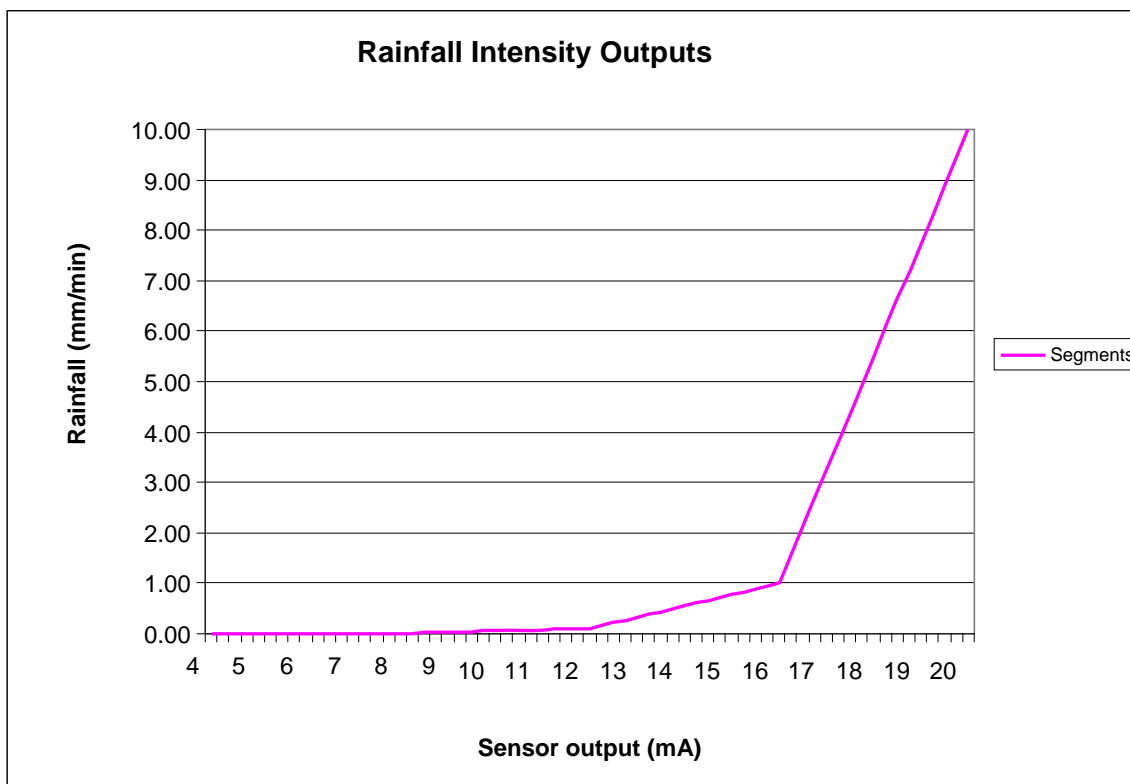

Figure 1 – Rainfall Intensity Outputs

3. Operation:

When the sensor is operational, light emitting diodes are used to create a light band across the sensor opening. As precipitation falls through the sensor opening a shadowing effect is seen in the light band, on the receiving side. The extent of shading and the duration of shading are used as factors to determine if a precipitation event is occurring, and are used to calculate intensity.

The light sent from the emitting diodes is pulse modulated so that ambient light cannot influence the measurement results.

In order to avoid icing and snow accumulation the sensor is equipped with a heating system. In freezing conditions the sensor housing will retain a temperature greater than 0°C by means of regulated heating.

4. Mounting:

The included mounting hardware is meant to attach the sensor to a mast or tower leg. The mounting hardware is to be used with a 34mm to 50mm (1 3/8 to 2 inch) outside diameter mast. When mounting the sensor be sure to avoid locations where rain shadowing will occur, or where the sensor will be subject to vibration or shock.

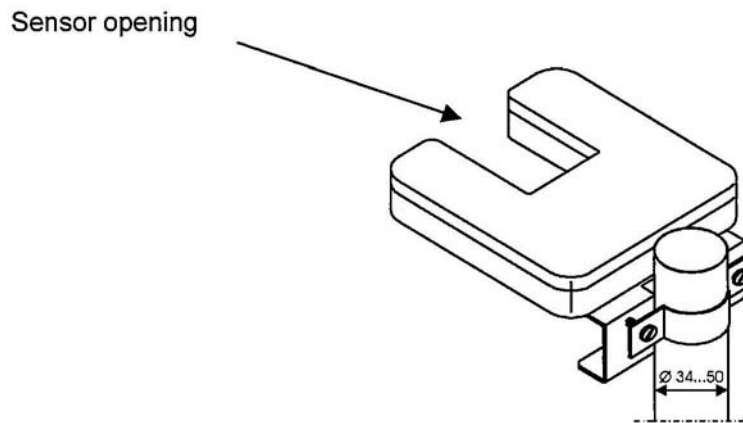

5. Wiring:

Two cables are connected to the base of the sensor to allow for the connection of both power and signal output. Be sure the main AC power source is disconnected and off while making the power and signal cable connections.

The FIN2PWR-L power cable will need to be connected to the C1966 AC transformer once the cable has been run into the appropriate location. The FIN2PWR-L cable will have crimp connectors attached to the end for ease of connection to the AC transformer. Table 1 provides a reference for the power supply wiring.

The FIN2COND-L signal output cable will need to be connected to a CURS100 current shunt, which in turn needs to be interfaced with the datalogger. First connect the FIN2COND-L to the CURS100 as listed in

Table 2. Once this is complete locate the CURS100 in the datalogger differential channel allocated to measure the sensor.

Wire Color	Function	Connection
Black (FIN2PWR-L)	Power Ground	L1 Terminal of AC Transformer (Crimp connector)
Red (FIN2PWR-L)	+24VAC Power	L2 Terminal of AC Transformer (Crimp connector)

Table 1 – Power Supply Wiring

Connections for CR800 series, CR1000, and CR3000 dataloggers

Wire Color	Function	Connection
White (FIN2COND-L)	Signal Output	CURS100 – H » Diff 1H
Black (FIN2COND-L)	Signal Reference	CURS100 – L » Diff 1L
Clear (FIN2COND-L)	Shield	Earth Ground

Table 2 – Differential Datalogger Connections

6. Program Examples:

This section provides a program example for the measurement of the TC041-L with a CR1000 datalogger. Precipitation occurrence and rainfall intensity are measured differentially with the use of the CURS100 current shunt module.

As the sensor outputs rainfall intensity in four linear characteristic segments, the program will need to account for this when calculating intensity. The datalogger program calculates a milliampere representation of the measured millivolt value in order to calculate rainfall for the specific characteristic segment.

6.1. Event Based Output Program Example

```
' CR1000 Series Datalogger
' Date: March 3rd, 2008
' Program Author: Campbell Scientific (Canada) Corp.
' Measure Thies Clima TC041-L Sensor on CR1000 with CURS100

' SENSOR AND PERIPHERAL WIRING:

' Thies Clima Precipitation Sensor Example
```

```

' 1H - CURS100* H - Current Signal
' 1L - CURS100* L - Current Ground
' AG - CURS100* G - Shield

' * NOTE: The CURS100 (100 Ohm current shunt) is a required component
of this wiring scheme.
'     The sensor outputs a 4-20mA signal that must be converted to a
voltage output
'     in order to be measured by the datalogger.

' DECLARE PUBLIC VARIABLES:

Public Rw
Public Rainfall_Rate
Public TmpRw
Public Prec_Occurance As String

' DECLARE UNITS

Units Rw = mA
Units Rainfall_Rate = mm/min
Units TmpRw = mA

' DATA TABLE DECLARATIONS

' One Minute Average of Raw Measurement
DataTable(Table1,true,1)
  TableHide
  DataInterval (0,1,Min,10)
  Average (1,Rw,FP2, 0)
EndTable

' Conditional One Minute Table of Rainfall Rate
' (will only occur if Precipitation Rate is greater than zero)
' *** Note: This output is valid for rainfall only. ***

DataTable (Rate_1min,Rainfall_Rate>0,-1)'Table size should be
customized for individual applications.
  DataInterval (0,1,Min,10)
  Sample (1,Rainfall_Rate,FP2)
  Sample (1,Prec_Occurance,String)
EndTable

' \\\\\\\\\\\\\\\\\\\\\\\\\\\\\\\\\\\\\\\\\ PROGRAM SECTION \\\\\\\\\\\\\\\\\\\\\\\\\\\\\\\\\\\\\\\\\

BeginProg
  Scan (5,Sec,0,0)

  ' Measure Precipitation (THIES CLIMA SENSOR)
  VoltDiff (Rw,1,mv5000,1,True ,0,_60Hz,0.01,0)

  ' Redirect Raw 1 Minute Precipitation Values in Order to Calculate
Rainfall Rate
  CallTable Table1
  If TimeIntoInterval (0,1,Min) Then GetRecord (TmpRw,Table1,1)

```



```

' \\\\\\\\\\\\\\\\\\\\\\\\\\\\\\\\\\\\\\\\\ Calculations \\\\\\\\\\\\\\\\\\\\\\\\\\\\\\\\\\\\\\\\\

' Determine Rate of Rainfall from the one minute average of the
raw
' Thies Clima sensor measurements.
' Use starting value of 4.4mA so that particles smaller than sensor
resolution (0.001 mm)
' are not counted as rainfall.

If TmpRw >= 4.4 AND TmpRw < 8 Then
  Rainfall_Rate = ((0.0025 * TmpRw) - 0.01) ' mm/min
ElseIf TmpRw >= 8 AND TmpRw < 12 Then
  Rainfall_Rate = ((0.0225 * TmpRw) - 0.17) ' mm/min
ElseIf TmpRw >= 12 AND TmpRw < 16 Then
  Rainfall_Rate = ((0.225 * TmpRw) - 2.6) ' mm/min
ElseIf TmpRw >= 16 AND TmpRw < 20 Then
  Rainfall_Rate = ((2.25 * TmpRw) - 35) ' mm/min
Else
  Rainfall_Rate = 0
EndIf

' Generate Precipitation Occurance Output based on Rainfall Rate.
If Rainfall_Rate >0 Then
  Prec_Occurance = "Yes"
Else
  Prec_Occurance = "No"
EndIf

' \\\\\\\\\\\\\\\\\\\\\\\\\\\\\\\\\\\\\\\\\ Output \\\\\\\\\\\\\\\\\\\\\\\\\\\\\\\\\\\\\\\\\

' Output Conditional 1-Minute Data if a Rainfall Event is occurring:
CallTable (Rate_1min)

NextScan
EndProg

```

7. Maintenance:

It is possible for a layer of dirt to form on the sensor and along the inside of the sensor opening. Typically this is washed off in a precipitation event. However, it is recommended to regularly check the sensor and clean the sensor opening and top with water and a non-abrasive cloth (unsoiled).