

Outline Dimension

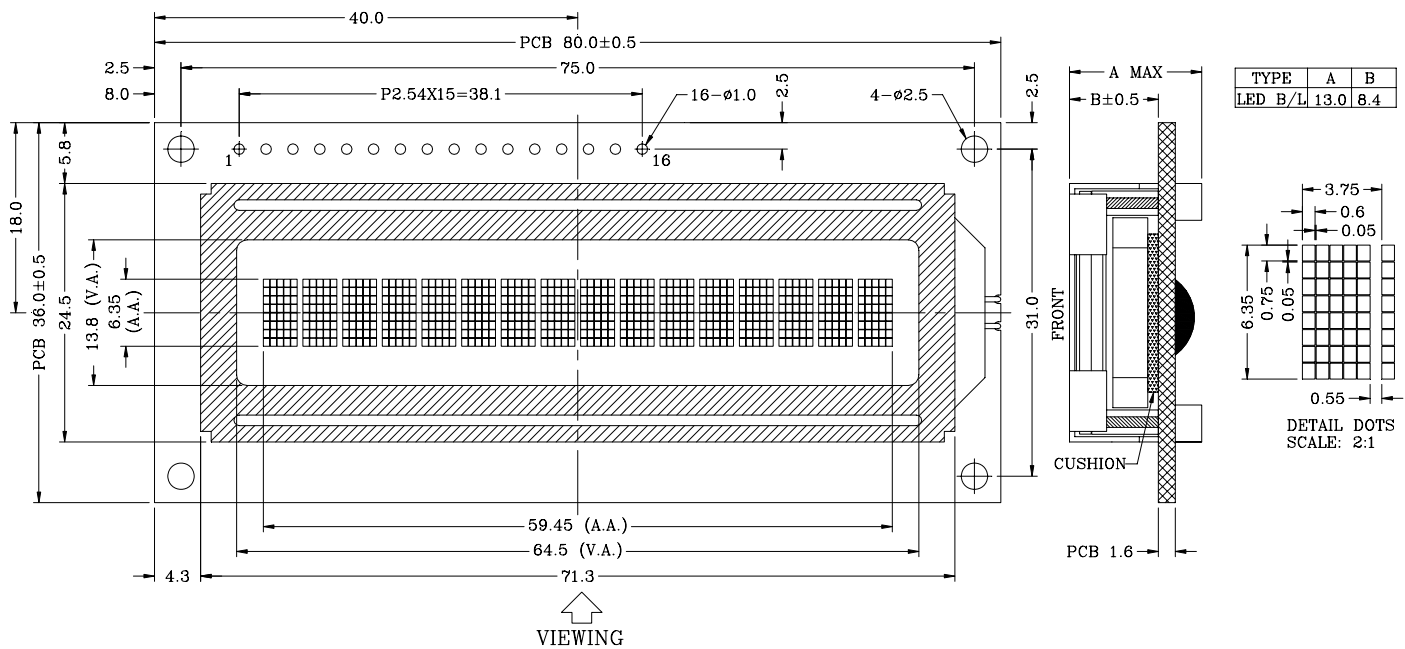

Feature :

- 16x1 Characters
- STN/TRANSMISSIVE/NEGATIVE/BLUE
- White/side-light (LED)
- Operating Temp.: -10°C ~ +60°C
- 1/16 duty cycle, 1/5 Bias
- Built-in Controller (SPLC780D1 or equivalent)
- Viewing angle: 6 o'clock

Absolute Maximum Rating :

Item	Symbol	Standard value			Unit
		M _{IN}	T _{YP}	M _{AX}	
Power supply for logic	V _{DD} -V _{SS}	-0.3	--	7.0	V
Input voltage	V _I	-0.3	--	V _{DD} +0.3	V

Adjusting Display Contrast :

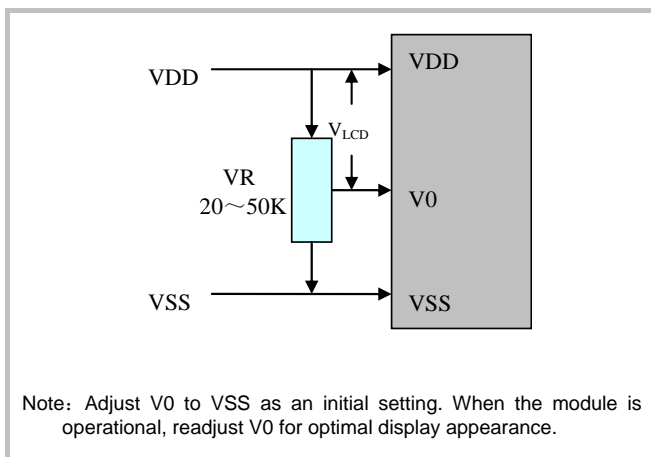

Electrical Characteristic :

Character Type

(V_{SS}=0V, T_a = 25°C)

Parameter	Symbol	Condition	M _{IN}	T _{YP}	M _{AX}	Unit
Supply voltage for logic	V _{DD}	--	4.8	5.0	5.2	V
Supply current for logic	I _{DD}	--	--	1	--	mA
Operating voltage for LCD	V _{LCD}	-10°C	--	--	--	V
		+25°C	--	5.0	--	V
		+60°C	--	--	--	V
Supply voltage for Backlight	V _{BL}	--	--	5.0	--	V
Supply current for Backlight	I _{BL}	--	--	15	--	mA

Interface Pin Connections :

Pin No.	Symbol	Level	Description
1	VSS	0V	Ground.
2	VDD	+5.0V	Supply voltage for logic operating.
3	V0	--	Adjusting voltage for LCD driving (variable).
4	RS	H/L	A signal for selecting registers: 1: Data Register (for read and write) 0: Instruction Register (for write), Busy flag-Address Counter (for read).
5	R/W	H/L	R/W = "H": Read mode. R/W = "L": Write mode.
6	E	H/L	An enable signal for writing or reading data.
7~14	DB0-DB7	H/L	8-bit bi-directional data bus.
15	LED+	+5.0V	Power supply for Backlight.
16	LED-	0V	The backlight ground.