



TC1601A

16CharsX1 Lines
1/16 Duty, 1/5Bias

External Dimension

<http://www.oppod.com>

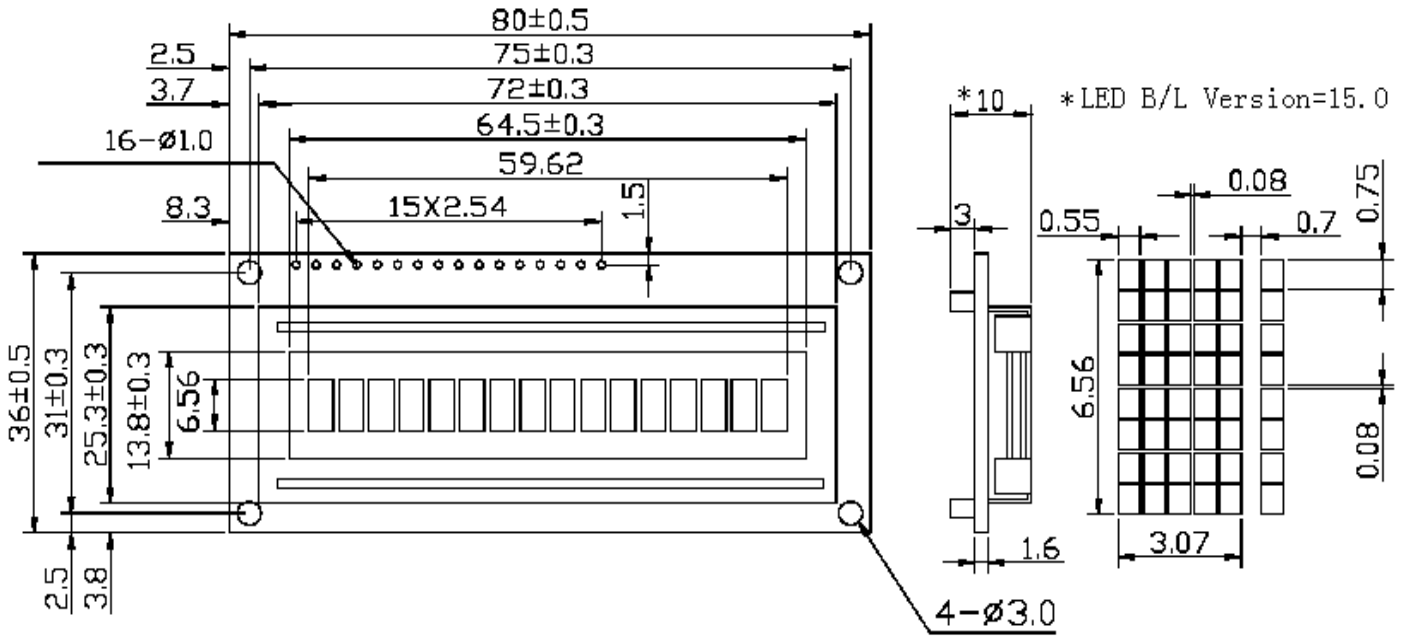

Mechanical Data

Item	Standard Value	Unit
Module size (W*H*T)	80.0*36.0*10.0/15.0	mm
View area (W*H)	64.5*13.8	mm
Active area (W*H)	59.62*6.56	mm
Dot size (W*H)	0.55*0.75	mm

Maximum Absolute Ratings

Item	Symbol	Value	Unit
Supply logic Volt.	$V_{DD} - V_{SS}$	-0.3 ~ +7.0	V
LCD driving Volt.	$V_{DD} - V_0$	-0.3 -13.0	V
Input Volt.	V_{in}	-0.3 ~ $V_{DD} + 0.3$	V
Operating temp.	T_{OPR}	-20 ~ +70	
Storage temp.	T_{STG}	-30 ~ +80	

Electrical Characteristics ($V_{DD} = 4.5V \sim 5.5V$)

Item	Symbol	Condition	Value	Unit
Supply logic Volt.	V_{DD}	---	5.0±0.5	V
Operating current	I_{DD}	$V_{DD}=5.0V$	0.5~2.0	mA
Input high volt.	V_{IH}	---	2.2~ V_{DD}	V
Input low volt.	V_{IL}	---	-0.3~0.6	V
Output high volt.	V_{oH}	$I_{oH}=-0.2mA$	2.4~ V_{DD}	V
Output low volt.	V_{oL}	$I_{oL}=1.2mA$	0~0.4	V
LCD driving volt.	V_{LCD}	$T_A=25$	4.5(Typ)	V

LED Backlight Characteristics ($T_A=25$)

Item	Symbol	Condition	Min	Typ	Max	Unit
Supply Volt.	V_f	---	---	4.1	---	V
Led Current	I_f	$T_A=25$	---	90	---	mA
Power Dissipation	P_d	---	---	380	---	mW

Interface Description

PIN	Symbol	Level	Description
1	V_{SS}	0V	Ground
2	V_{DD}	5.0V	Power supply for Logic
3	V_0	Variable	Driving voltage for LCD
4	RS	H/L	H:Data L:Instruction
5	RW	H/L	H:Read L:Write
6	E	H/L	Enable
7	DB0	H/L	In 8-bit mode, used as low order data bus. In 4-bit bus mode open these pins.
8	DB1	H/L	
9	DB2	H/L	
10	DB3	H/L	
11	DB4	H/L	In 8-bit mode, used as high data bus. In 4-bit mode, used as both high and low order. DB7 is used for Busy Flag .
12	DB5	H/L	
13	DB6	H/L	
14	DB7	H/L	
15	A	+5V	Anode of LED Backlight
16	K	0V	Cathode of LED Backlight

Block Diagram

