

# TC1602A

\* 16 Characters 2 line \* Controller LSI built-in \* +5V single power supply

## EXTERNAL DIMENSIONS AND DISPLAY PATTERN

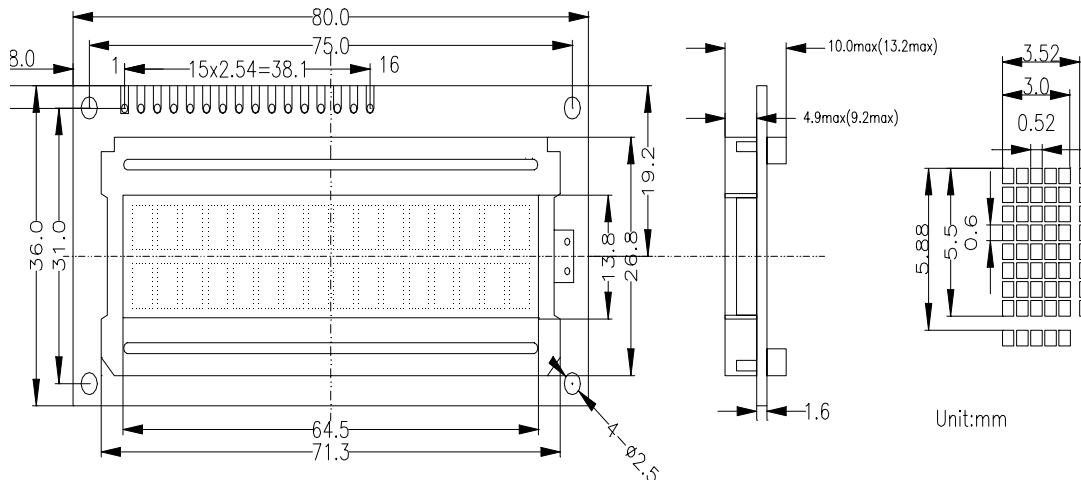

### MECHANICAL DATA(Nominal dimensions)

Module size ----- 80.0WX36.0HX10.0Dmm  
 Effective display area ----- 64.5WX13.8H mm  
 Charater size(5X8dots) ----- 3.0WX5.5H mm  
 Charater pitch ----- 3.52X5.88 mm  
 Dot size ----- 0.52WX0.60H mm  
 Weight ----- about 40 g

### ABSOLUTE MAXIMUM RATINGS min max.

Power supply for logic (Vdd - Vss) ---- 0 7.0V  
 Power supply for LCD drive(Vdd-Vo) - - 0 5.0V  
 Input voltage (Vi) ----- Vss Vdd V  
 Operating temperature (Ta) ----- 0 55c  
 Storage temperature (Tstg) ----- -20 60c

### ELECTRICAL CHARACTERISTICS

Ta = 25c, Vdd = 5.0 + 0.25V  
 Input 'high' voltage (Vih) ----- 3.5V min.  
 Input 'low' voltage (Vil) ----- 0.55V max.  
 Output 'high' voltage(Voh)(-Ioh=0.1mA) --- 3.75V min.  
 Output low' voltage(Vol)(Iol = 0.1mA) ---- 1.0V max.  
 Power supply current(Idd (Vdd=5.0 V) --- 2.0mAmax.  
 Drive method ----- 1/16 Duty, 1/5 Bias.

### PIN CONNECTION

Pin No.	symbol	Lever	Function
1	Vss	--	0V
2	Vdd	--	+5V
3	Vo	--	--
4	RS	H/L	L:Instruction code input H:Data input
5	R/W	H/L	H:Data read L : Data write
6	E	H,H-L	Enable singal
7	D0	H/L	Data bus line *
8	D1	H/L	
9	D2	H/L	
10	D3	H/L	
11	D4	H/L	
12	D5	H/L	
13	D6	H/L	
14	D7	H/L	
15	LED+	5V	Power supply for LED
16	LED-	0V	Power supply for LED

\* In case of 4 bits instruction, data is transferrred by twice using only 4 buses of D4 - D7 ,and D0 - D3 are not used , first operation is higher order 4 bits and second is lower 4 bits of 8 bits , but in case of 8 bits instruction , data is transferred by data by data bus of D0 - D7.

### BLOCK DIAGRAM

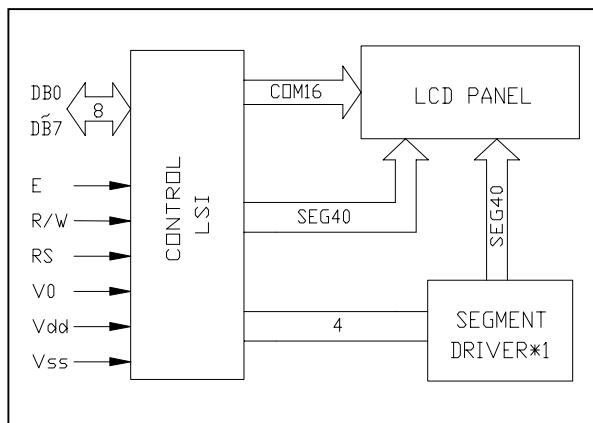

### POWER SUPPLY

