

## Plastic Packaged Low Noise PHEMT GaAs FETs

### FEATURES

- 1.5 dB Typical Noise Figure at 12 GHz
- High Associated Gain:  $G_a = 6.5$  dB Typical at 12 GHz
- 21.5 dBm Typical Power at 12 GHz
- 7.5 dB Typical Linear Power Gain at 12 GHz
- $L_g = 0.25 \mu\text{m}$ ,  $W_g = 300 \mu\text{m}$
- Tight  $V_p$  ranges control
- High RF input power handling capability
- 100 % DC Tested
- Low Cost Plastic SOT143 Package

### PHOTO ENLARGEMENT



### DESCRIPTION

The TC2211 is a high performance field effect transistor housed in a plastic package with TC1201 PHEMT Chip. Its low noise figure makes this device suitable for use in low noise amplifiers. All devices are 100 % DC tested to assure consistent quality.

### ELECTRICAL SPECIFICATIONS ( $T_A = 25^\circ\text{C}$ )

Symbol	CONDITIONS	MIN	TYP	MAX	UNIT
NF	Noise Figure at $V_{DS} = 4 \text{ V}$ , $I_{DS} = 25 \text{ mA}$ , $f = 12\text{GHz}$		1.5	2	dB
$G_a$	Associated Gain at $V_{DS} = 4 \text{ V}$ , $I_{DS} = 25 \text{ mA}$ , $f = 12\text{GHz}$	5.5	6.5		dB
$P_{1dB}$	Output Power at 1dB Gain Compression Point, $f = 12\text{GHz}$ $V_{DS} = 6 \text{ V}$ , $I_{DS} = 40 \text{ mA}$	20.5	21.5		dBm
$G_L$	Linear Power Gain, $f = 12\text{GHz}$ $V_{DS} = 6 \text{ V}$ , $I_{DS} = 40 \text{ mA}$	6.5	7.5		dB
$I_{DSS}$	Saturated Drain-Source Current at $V_{DS} = 2 \text{ V}$ , $V_{GS} = 0 \text{ V}$		90		mA
$g_m$	Transconductance at $V_{DS} = 2 \text{ V}$ , $V_{GS} = 0 \text{ V}$		100		mS
$V_p$	Pinch-off Voltage at $V_{DS} = 2 \text{ V}$ , $I_D = 0.6\text{mA}$		-1.0*		Volts
$BV_{DGO}$	Drain-Gate Breakdown Voltage at $I_{DGO} = 0.15\text{mA}$	9	12		Volts
$R_{th}$	Thermal Resistance		150		$^\circ\text{C/W}$

### ABSOLUTE MAXIMUM RATINGS ( $T_A = 25^\circ\text{C}$ )

Symbol	Parameter	Rating
$V_{DS}$	Drain-Source Voltage	7.0 V
$V_{GS}$	Gate-Source Voltage	-3.0 V
$I_{DS}$	Drain Current	$I_{DSS}$
$I_{GS}$	Gate Current	300 $\mu\text{A}$
$P_{in}$	RF Input Power, CW	21 dBm
$P_T$	Continuous Dissipation	400 mW
$T_{CH}$	Channel Temperature	175 $^\circ\text{C}$
$T_{STG}$	Storage Temperature	- 65 $^\circ\text{C}$ to +175 $^\circ\text{C}$

\* For the tight control of the pinch-off voltage range, we divide TC2211 into 3 model numbers to fit customer design requirement

(1) TC2211P0710 :  $V_p = -0.7\text{V}$  to  $-1.0\text{V}$

(2) TC2211P0811 :  $V_p = -0.8\text{V}$  to  $-1.1\text{V}$

(3) TC2211P0912 :  $V_p = -0.9\text{V}$  to  $-1.2\text{V}$

If required, customer can specify the requirement in purchasing document. For special  $V_p$  requirement, please contact factory for details.

**TYPICAL SCATTERING PARAMETERS (T<sub>A</sub>=25 °C)**

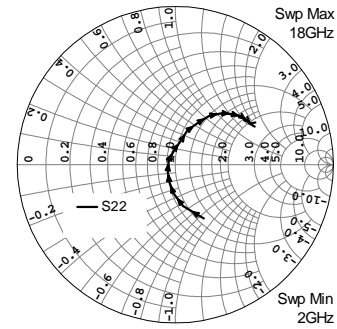
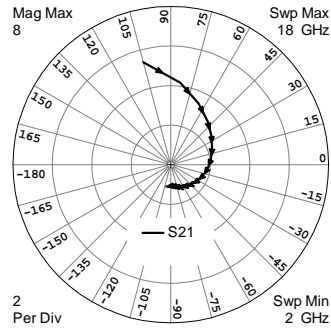
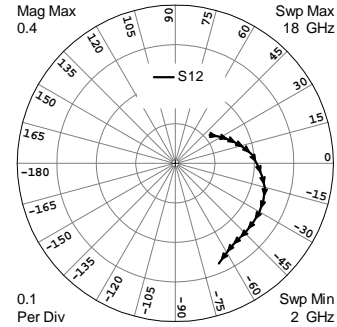
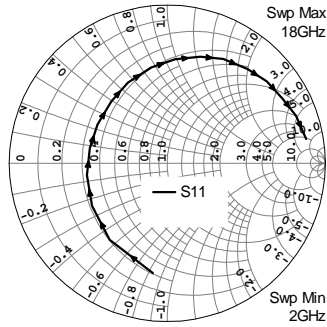
 V<sub>DS</sub> = 4 V, I<sub>DS</sub> = 25 mA

FREQUENCY (GHz)	S11		S21		S12		S22	
	MAG	ANG	MAG	ANG	MAG	ANG	MAG	ANG
2	0.6999	-97.55	5.3659	105.10	0.1127	39.71	0.3838	-62.15
3	0.6047	-127.04	4.1625	83.38	0.1340	29.75	0.2657	-79.50
4	0.5465	-150.57	3.3927	65.51	0.1502	23.32	0.1809	-93.67
5	0.5139	-171.52	2.8823	49.75	0.1655	17.33	0.1122	-110.30
6	0.4983	169.10	2.5261	35.13	0.1806	12.00	0.0610	-142.34
7	0.5047	150.95	2.2504	21.36	0.1952	6.37	0.0498	144.49
8	0.5278	132.16	2.0333	5.81	0.2094	-1.70	0.0917	95.82
9	0.5677	116.10	1.8558	-7.76	0.2228	-8.89	0.1539	76.92
10	0.6139	99.71	1.7107	-20.59	0.2353	-15.49	0.2262	70.78
11	0.6598	85.73	1.5598	-32.59	0.2422	-22.95	0.2942	62.32
12	0.7045	72.88	1.4317	-44.68	0.2461	-30.44	0.3747	55.37
13	0.7477	61.79	1.3153	-55.99	0.2473	-37.31	0.4407	47.71
14	0.7818	49.72	1.2204	-67.41	0.2490	-44.51	0.4846	41.21
15	0.8152	39.40	1.1386	-76.80	0.2493	-50.20	0.5174	36.25
16	0.8366	29.31	1.0922	-85.95	0.2537	-55.96	0.5359	31.19
17	0.8672	20.34	1.0896	-94.23	0.2626	-61.00	0.5428	28.40
18	0.8923	9.98	1.1270	-101.69	0.2760	-66.50	0.5334	29.19

**TYPICAL SCATTERING PARAMETERS (T<sub>A</sub>=25 °C)**

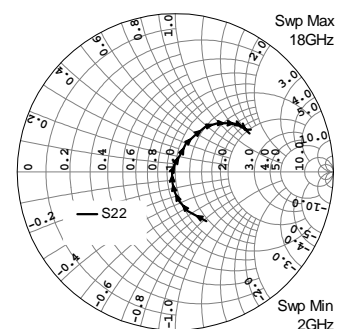
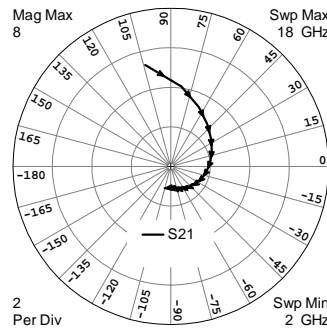
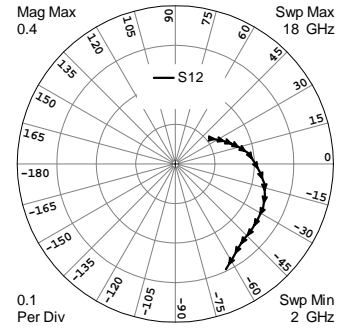
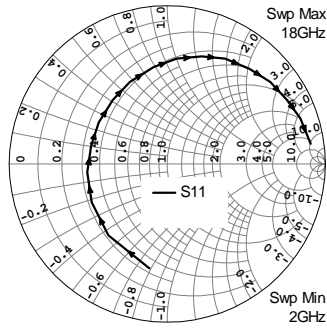
 V<sub>DS</sub> = 6 V, I<sub>DS</sub> = 40 mA

FREQUENCY (GHz)	S11		S21		S12		S22	
	MAG	ANG	MAG	ANG	MAG	ANG	MAG	ANG
2	0.6681	-99.70	5.2865	104.24	0.1064	37.18	0.3684	-57.65
3	0.5858	-129.55	4.0847	82.50	0.1263	28.85	0.2591	-72.46
4	0.5351	-153.10	3.3207	64.67	0.1422	23.08	0.1812	-83.40
5	0.5082	-173.98	2.8250	48.98	0.1567	18.11	0.1171	-93.75
6	0.4947	166.69	2.4709	34.40	0.1713	13.24	0.0609	-108.93
7	0.5062	148.64	2.2092	20.39	0.1869	8.46	0.0211	175.98
8	0.5316	130.28	2.0052	5.27	0.2008	0.85	0.0565	89.27
9	0.5694	114.69	1.8259	-8.54	0.2155	-5.75	0.1177	72.69
10	0.6175	98.32	1.6860	-21.35	0.2301	-12.29	0.1898	69.23
11	0.6674	84.96	1.5447	-33.79	0.2406	-19.60	0.2610	62.03
12	0.7144	72.20	1.4328	-45.93	0.2483	-26.65	0.3431	56.25
13	0.7593	61.19	1.3122	-57.56	0.2510	-33.66	0.4079	49.11
14	0.7959	49.10	1.2180	-69.19	0.2553	-41.18	0.4555	42.41
15	0.8324	38.47	1.1482	-79.01	0.2575	-47.12	0.4943	37.80
16	0.8584	28.11	1.0956	-88.46	0.2644	-52.66	0.5161	32.93
17	0.8894	18.77	1.0979	-97.09	0.2779	-58.43	0.5213	30.50
18	0.9160	8.01	1.1489	-105.25	0.2951	-64.37	0.5137	31.58

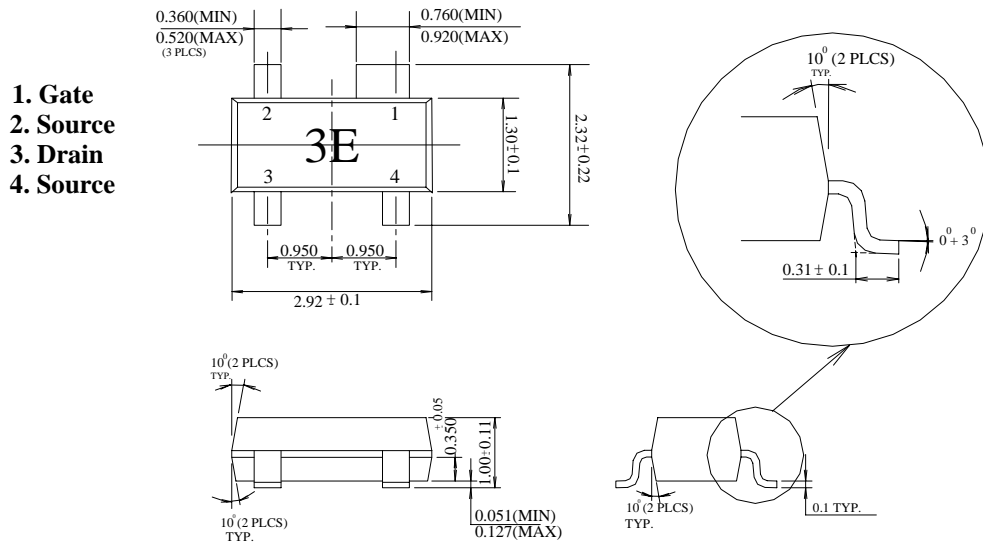
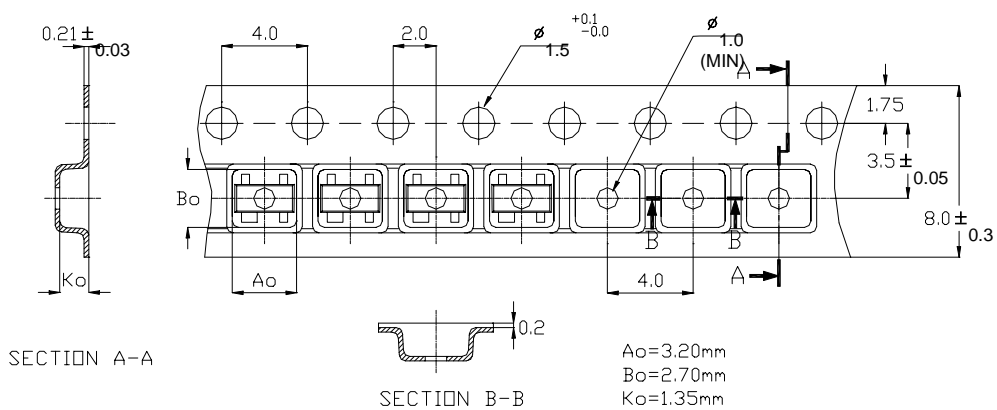
**OUTLINE DIMENSIONS (Unit : mm)**

**Tape & Reel Package Orientation (Unit:mm)**

Standard Reel Size	7"
Standard Reel Quantity	3000