

## TC35096P 8 BIT 4-CH SERIAL I/O ANALOG TO DIGITAL CONVERTER

### GENERAL DESCRIPTION

The TC35096P is a monolithic CMOS 8 bit successive approximation A/D converter with serial I/O and 4 channel multiplex inputs.

Conversion start when  $\overline{CS}$  is set low and start bit ("L" level) and channel select bit (two bits) are given to serial input DI.

In case that  $\overline{SE}$  is high, as soon as the conversion starts a start bit ("L" level) appears at serial output DO and 8 bit conversion data (MSB first) and a stop bit ("H" level) follow continuously.

In case that  $\overline{SE}$  is low, after the conversion is completed a start bit, 8 bit conversion data (LSB first) and a stop bit appear at DO.

The TC35096P has features of high speed, high accuracy and microprocessor compatible I/O which make the device well suited to a broad application field such as process and machine control and automotive equipment.

### FEATURES

- High accuracy .....  $\pm \frac{3}{4}$  LSB MAX
- High speed conversion ..... 32.5  $\mu$ s MAX @  $f_{CP}=400$  kHz
- Single power supply ..... 5V  $\pm$  10%
- Low power consumption ..... 5 mW MAX @  $T_a=25^\circ\text{C}$
- Serial I/O
- 4 channel analog multiplex input
- Easy interface to all microprocessors
- 3-state output
- Zero or full scale adjustment free

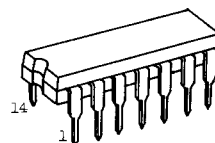

DIP 14(3Di4A-P)

### ABSOLUTE MAXIMUM RATINGS

PARAMETER	SYMBOL	VALUE	UNIT
Supply Voltage Range	VDD	VSS-0.5 ~ VSS+7	V
DC Input Voltage	VIN	VSS-0.5 ~ VDD+0.5	V
DC Output Voltage	VOUT	VSS-0.5 ~ VDD+0.5	V
Reference Voltage	VREF	VSS-0.5 ~ VDD+0.5	V
Analog Ground Voltage	AGND	VSS-0.5 ~ VDD+0.5	V
DC Input Current	IIN	$\pm 10$	V
Power Dissipation	PD	300	mA
Storage Temperature	T <sub>stg</sub>	-65 ~ 150	$^\circ\text{C}$
Lead Temperature 10 sec.	T <sub>L</sub>	300	$^\circ\text{C}$

### PIN ASSIGNMENT

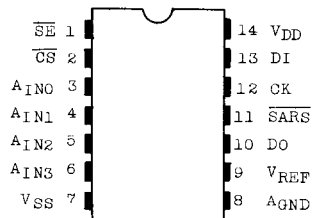

(TOP VIEW)

BLOCK DIAGRAM

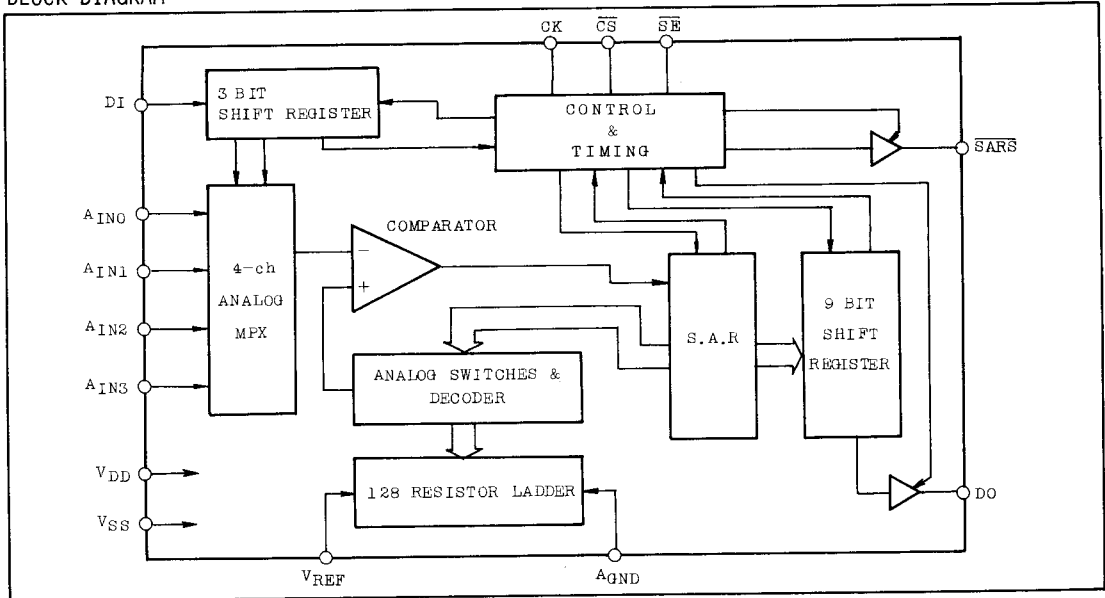

TIMING CHART

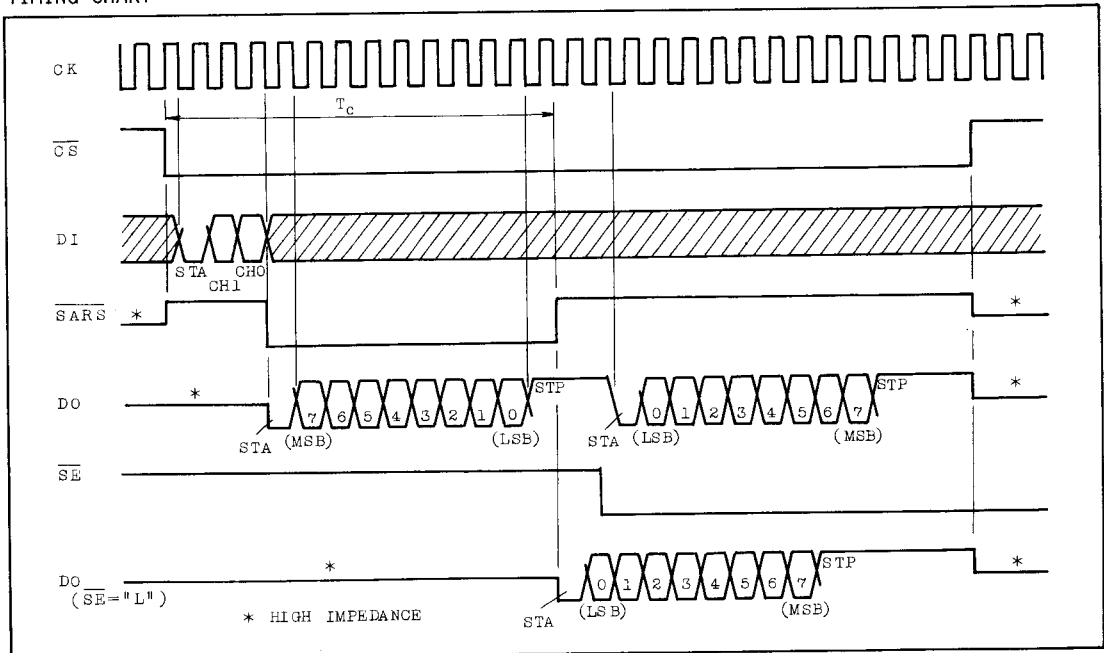

PIN & FUNCTION

PIN NO.	SYMBOL	PIN NAME & FUNCTION	PIN NO.	SYMBOL	PIN NAME & FUNCTION																	
1	$\overline{SE}$	[SELECT] $\overline{SE}$ determines the order of output data. $\overline{SE}$ = "L" .... LSB first $\overline{SE}$ = "H" .... MSB first	8	$A_{GND}$	[ANALOG GROUND] $A_{GND}$ defines the zero level of $A_{IN}$ .																	
2	$\overline{CS}$	[CHIP SELECT] At the falling edge of $\overline{CS}$ , the device is set stand-by for conversion. When $\overline{CS}$ is "H" the device is reset and all outputs become high impedance.	9	$V_{REF}$	[REFERENCE VOLTAGE] $V_{REF}$ defines the full scale of $A_{IN}$ .																	
			10	DO	[DATA OUTPUT] Output data is sent out in series.																	
3	$A_{IN0}$	[ANALOG INPUT] One of $A_{IN0} \sim A_{IN3}$ is selected according to the serial channel select bit applied on DI input. Full range of input signal is to be from $A_{GND}$ to $V_{REF}$ .	11	$\overline{SARS}$	[SAR STATUS] When a start bit ("L" level) is detected at DI input, $\overline{SARS}$ is set "L" level and conversion starts. When conversion is completed $\overline{SARS}$ returns to "H" level.																	
4	$A_{IN1}$																					
5	$A_{IN2}$																					
6	$A_{IN3}$																					
		<table border="1"> <thead> <tr> <th rowspan="2">ON Channel</th> <th colspan="2">DI Serial Data</th> </tr> <tr> <th>CH1</th> <th>CH0</th> </tr> </thead> <tbody> <tr> <td><math>A_{IN0}</math></td> <td>L</td> <td>L</td> </tr> <tr> <td><math>A_{IN1}</math></td> <td>L</td> <td>H</td> </tr> <tr> <td><math>A_{IN2}</math></td> <td>L</td> <td>L</td> </tr> <tr> <td><math>A_{IN3}</math></td> <td>H</td> <td>H</td> </tr> </tbody> </table>	ON Channel	DI Serial Data		CH1	CH0	$A_{IN0}$	L	L	$A_{IN1}$	L	H	$A_{IN2}$	L	L	$A_{IN3}$	H	H	12	CK	[CLOCK INPUT] Basic system clock. Duty cycle is to be 50%.
ON Channel	DI Serial Data																					
	CH1	CH0																				
$A_{IN0}$	L	L																				
$A_{IN1}$	L	H																				
$A_{IN2}$	L	L																				
$A_{IN3}$	H	H																				
			13	DI	[DATA INPUT] For starting conversion, a start bit ("L" level) and channel select bit (from CH1 to CH0 in order) are to be applied.																	
7	$V_{SS}$	[DIGITAL GROUND]	14	$V_{DD}$	[POWER SUPPLY] 5V ±10%																	

# TC35096P

## RECOMMENDED OPERATING CONDITIONS (V<sub>SS</sub>=0V)

PARAMETER	SYMBOL	CONDITION	MIN.	TYP.	MAX.	UNIT
Supply Voltage	V <sub>DD</sub>		4.5	5.0	5.5	V
Input Voltage	V <sub>IN</sub>		0	-	V <sub>DD</sub>	V
Reference Voltage	V <sub>REF</sub>	V <sub>DD</sub> =5V, AGND=0V	2.0	V <sub>DD</sub>	V <sub>DD</sub>	V
Analog Ground Voltage	AGND	V <sub>DD</sub> =5V, V <sub>REF</sub> =5V	0.0	0.0	3.0	V
Voltage Between V <sub>REF</sub> and AGND		V <sub>DD</sub> =5V ± 10%	2.0	V <sub>DD</sub>	V <sub>DD</sub>	V
Clock Frequency	f <sub>CP</sub>	V <sub>DD</sub> =5V ± 10%	-	-	400	kHz
Clock Pulse Width	t <sub>w(H)</sub> t <sub>w(L)</sub>	V <sub>DD</sub> =5V ± 10%	0.63	1.25	-	μs
Operating Temperature	t <sub>opr</sub>		-40	-	+85	°C

## DC ELECTRICAL CHARACTERISTICS (V<sub>DD</sub>=5V±10%, V<sub>SS</sub>=0V)

PARAMETER	SYMBOL	TEST CONDITION	25°C			-40 85°C		
High Level Output Voltage	V <sub>OH</sub>	I <sub>OUT</sub>   < 1μA V <sub>IN</sub> =V <sub>SS</sub> , V <sub>DD</sub>	V <sub>DD</sub> - 0.05	V <sub>DD</sub>	-	V <sub>DD</sub> - 0.05	-	V
Low Level Output Voltage	V <sub>OL</sub>	I <sub>OUT</sub>   < 1μA V <sub>IN</sub> =V <sub>SS</sub> , V <sub>DD</sub>	-	0.00	0.05	-	0.05	V
High Level Output Current	I <sub>OH</sub>	V <sub>OH</sub> =V <sub>DD</sub> -0.4V V <sub>IN</sub> =V <sub>SS</sub> , V <sub>DD</sub>	-0.44	-	-	-0.36	-	mA
Low Level Output Current	I <sub>OL</sub>	V <sub>OL</sub> =0.4V V <sub>IN</sub> =V <sub>SS</sub> , V <sub>DD</sub>	2.0	-	-	1.6	-	mA
High Level Input Voltage	V <sub>IH</sub>	I <sub>OUT</sub>   < 1μA V <sub>OUT</sub> =0.5V, V <sub>DD</sub> -0.5V	0.7 × V <sub>DD</sub>	-	-	0.7 × V <sub>DD</sub>	-	V
Low Level Input Voltage	V <sub>IL</sub>	I <sub>OUT</sub>   < 1μA V <sub>OUT</sub> =0.5V, V <sub>DD</sub> -0.5V		-	0.3 × V <sub>DD</sub>	-	0.3 × V <sub>DD</sub>	V
3-State Output Disable Current	I <sub>DH</sub> I <sub>DL</sub>	V <sub>OH</sub> =V <sub>DD</sub> or V <sub>OL</sub> =0.0V		-	±0.5	-	±1	μA
Digital Input Current	I <sub>IH</sub> I <sub>IL</sub>	V <sub>IH</sub> =V <sub>DD</sub> or V <sub>IL</sub> =0.0V		-	±0.3	-	±1	μA
ON Channel Input Current	I <sub>ON</sub>	V <sub>IH</sub> =V <sub>REF</sub> or V <sub>IL</sub> =0.0V f <sub>CP</sub> =400kHz	-	-	±2	-	±5	μA
OFF Channel Input Current	I <sub>OFF</sub>	V <sub>IH</sub> =V <sub>DD</sub> or V <sub>IL</sub> =0.0V	-	-	±0.2	-	±1	μA
Operating Current	I <sub>DD</sub>	f <sub>CP</sub> =400kHz	-	-	1.1		1.4	mA
Reference Resistance	R <sub>REF</sub>		1.4	2.6	3.8	1.2	4.2	kΩ

## SWITCHING CHARACTERISTICS (V<sub>DD</sub>=5V±10%, V<sub>SS</sub>=0V, Ta=25°C)

PARAMETER	SYMBOL	TEST CONDITION	MIN.	TYP.	MAX.	UNIT
Output Transition Time	t <sub>TLH</sub> t <sub>THL</sub>	C <sub>L</sub> =50pF	-		100	nS
Propagation Delay Time (CK-Data)	t <sub>pLH</sub> t <sub>pHL</sub>	C <sub>L</sub> =50pF	-		250	
Propagation Delay Time (CK- $\overline{\text{SARS}}$ )	t <sub>pLH</sub> t <sub>pHL</sub>	C <sub>L</sub> =50pF	-		250	
3-State Output Enable Time ( $\overline{\text{CS}}-\overline{\text{SARS}}$ , $\overline{\text{SARS}}$ -Data)	t <sub>pZH</sub> t <sub>pZL</sub>	C <sub>L</sub> =50pF R <sub>L</sub> =1kΩ	-		200	
3-State Output Disable Time ( $\overline{\text{CS}}-\overline{\text{SARS}}$ , Data)	t <sub>pHZ</sub> t <sub>pLZ</sub>		-		200	
Minimum Pulse Width ( $\overline{\text{CS}}$ )	t <sub>w(H)</sub>	C <sub>L</sub> =50pF	-		100	
Minimum Set-up Time ( $\overline{\text{CS}}$ , $\overline{\text{SE}}$ , DI)	t <sub>s</sub>	C <sub>L</sub> =50pF	-		150	
Minimum Hold Time (DI)	t <sub>h</sub>	C <sub>L</sub> =50pF	-		50	
Input Capacitance	C <sub>IN1</sub>	Digital Input	-	5	-	pF
Input Capacitance	C <sub>IN2</sub>	Analog In(ON)	-	5	-	
Input Capacitance	C <sub>IN3</sub>	Analog In(OFF)	-	5	-	
Output Capacitance	C <sub>OUT</sub>	3-State Out	-	10	-	

## SWITCHING CHARACTERISTICS TEST WAVEFORM

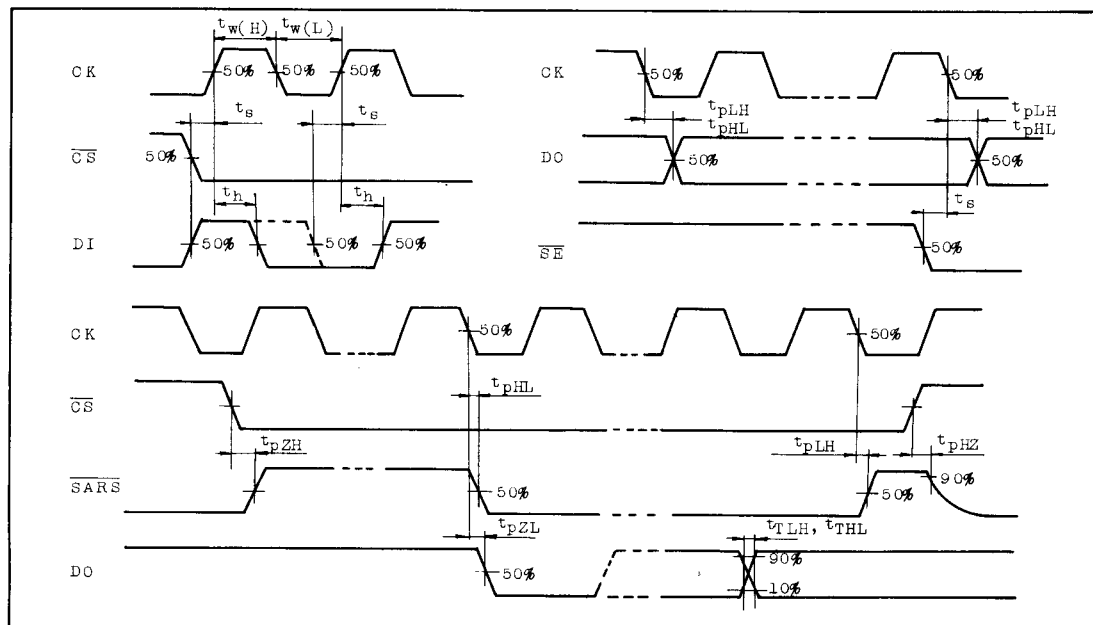

# TC35096P

## 3-STATE OUTPUT TEST CIRCUIT

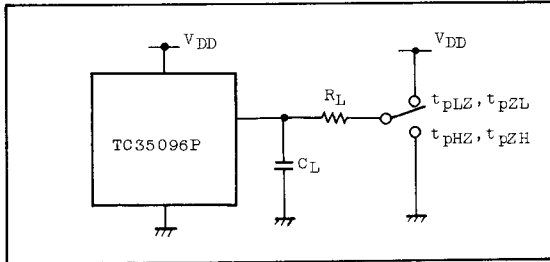

## SYSTEM CHARACTERISTICS ( $T_a = -40 \sim 85^\circ\text{C}$ )

PARAMETER	SYMBOL	TEST CONDITION	MIN.	TYP.	MAX.	UNIT
Zero Point Error	$E_{ZR}$	$V_{DD}=5.0\text{V}$ $V_{REF}=5.000\text{V}$ $f_{cp}=400\text{kHz}$ Duty=50%	-	$\pm 1/4$	$\pm 1/2$	LSB
Full Scale Error	$E_{FS}$		-	$\pm 1/4$	$\pm 1/2$	
Nonlinearity Error	$E_{LI}$		-	$\pm 1/4$	-	
Total Error	$E_T$		-	$\pm 1/4$	$\pm 3/4$	
Conversion Time	TC	$f_{cp}=400\text{kHz}$	-	32.5	34	$\mu\text{S}$

## APPLICATION CIRCUIT (EXAMPLE)

$$T_c = \frac{13}{f_{cp}} + \alpha \quad 0 < \alpha < \frac{1}{2f_{cp}}$$

