



Lithium-Ion Battery Charger

FEATURES

- Low Power Dissipation
- Shutdown Current: 1 μ A (Typical)
- Space-Saving 8-Pin MSOP Package
- No Inductor Required
- 1% Overall System Accuracy
- Charge Current Monitor Output
- Charge Status Indicator Output
- Foldback Current Limiting
- -20°C to +85°C Ambient Operating Temperature Range

TYPICAL APPLICATIONS

- PDAs
- Cradle Chargers
- Li-Ion Battery Chargers
- Desktop Computers
- Hand-Held Instruments
- Cellular Telephones
- Battery Operated Devices
- Self-Charging Battery Packs

PIN CONFIGURATION

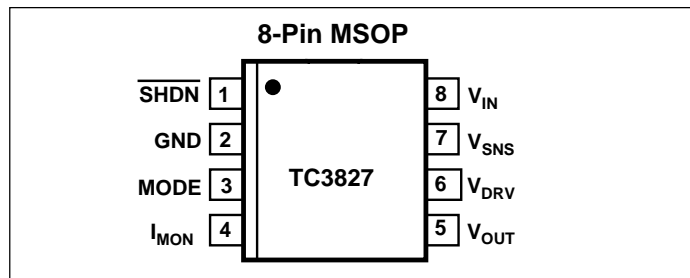

TYPICAL APPLICATION CIRCUIT

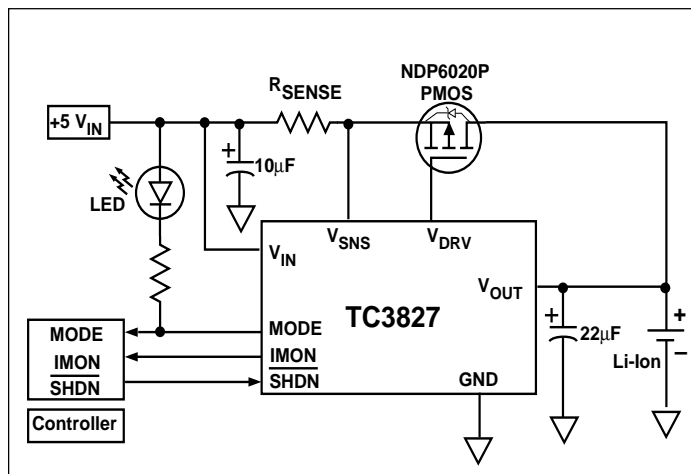

Figure 1. TC3827 Typical Application Circuit

GENERAL DESCRIPTION

The TC3827 is a battery charger controller for a single cell Li-Ion battery. Using an external PMOS transistor, safe and fast charging of a single Li-Ion cell is accomplished.

Features include over-current foldback, charge current monitor, and charge status LED indicator output. An overall system accuracy of 1% ensures that the cell capacity is fully utilized without cycle life degradation. An external resistor sets charge current.

The TC3827 operates with an input voltage range from 4.5V to 5.5V. It is specified over the ambient operating temperature range of -20°C to +85°C and is available in a space-saving 8-Pin MSOP.

ORDERING INFORMATION

Part No.	Package	Temperature Range
TC3827-4.1VUA	8-Pin MSOP	-20°C to +85°C
TC3827-4.2VUA	8-Pin MSOP	-20°C to +85°C

FUNCTIONAL BLOCK DIAGRAM

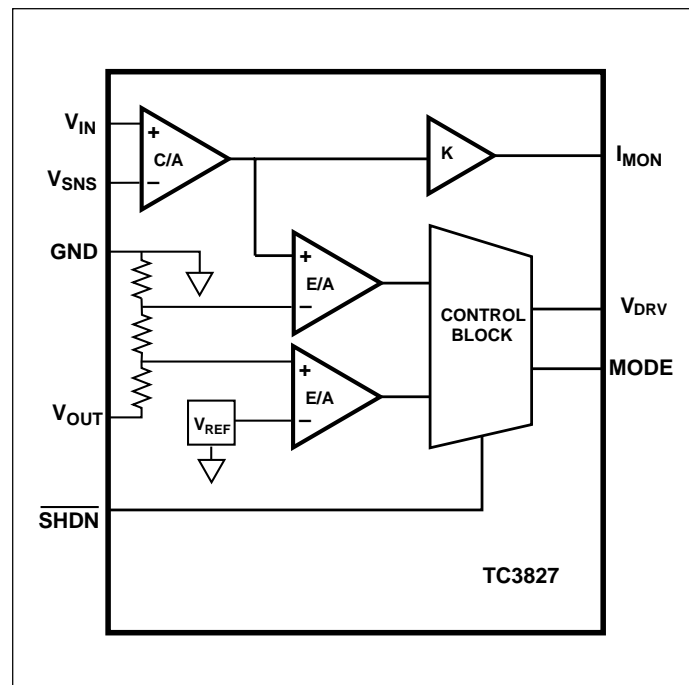

TC3827

ABSOLUTE MAXIMUM RATINGS*

Input Voltage (V_{IN}), V_{OUT} , V_{SNS} , MODE, and I_{MON}	-0.3V to 6.0V
\overline{SHDN}	-0.3V to ($V_{IN} + 0.3V$)
8-Pin MSOP (derate 4.1mW/°C above +70°C)	330mW
Operating Ambient Temperature Range ..	-20°C to +85°C
Storage Temperature Range	-65°C to +150°C
Lead Temperature (Soldering, 10 sec)	+300°C
Vapor Phase (60 sec)	+210°C
Infrared (15 sec)	+220°C
I_{MON} (source)	0.375mA

I_{MODE} (sink)	20mA
I_{DRV}	1mA
ESD Rating	2kV

*Static-sensitive device. Unused devices must be stored in conductive material. Protect devices from static discharge and static fields. Stresses above those listed under Absolute Maximum Ratings may cause permanent damage to the device. These are stress ratings only and functional operation of the device at these or any other conditions above those indicated in the operational sections of the specifications is not implied. Exposure to Absolute Maximum Rating Conditions for extended periods may affect device reliability.

ELECTRICAL CHARACTERISTICS: $V_{IN} = [V_{REG} + 1V]$, $T_A = -20^\circ\text{C}$ to $+85^\circ\text{C}$, unless otherwise noted. Typical values at $T_A = +25^\circ\text{C}$, $R_{SENSE} = 500\text{m}\Omega$, Test Circuit Figure 3.

Symbol	Parameter	Test Conditions	Min	Typ	Max	Units
I_{VIN}	Power Supply Current	Shutdown Mode, $V_{SHDN} = 0V$ Constant Voltage Mode	— —	1 350	15 560	μA
V_{IN}	Power Supply Voltage In		4.5	—	5.5	V
Voltage Regulation (Constant Voltage Mode)						
V_{REG}	Battery Regulation Volts	3827- 4.2VUA 3827- 4.1VUA	— —	4.2 4.1	— —	V
V_{OUT}	Output Voltage Accuracy	$V_{IN} = V_{REG} + 1V$ to 5.5V,	-1	—	+1	%
LI_{REG}	Line Regulation	$V_{IN} = 4.5V$ to 5.5V, $I_{OUT} = 75\text{mA}$	-10	—	+10	mV
LD_{REG}	Load Regulation	$I_{OUT} = 10\text{mA}$ to 75mA	-1	± 0.2	+1	mV
ID_{ISCH}	Output Reverse Leakage	$V_{IN} = \text{Floating}$, $V_{OUT} = V_{REG}$	—	1	5	μA
MOSFET Gate Drive						
I_{DRV}	Gate Drive Current	Sink, Constant Voltage Mode (Note 1) Source, Constant Voltage Mode (Note 1)	— 0.08	— —	1 —	mA
V_{DRV}	Gate Drive Min Voltage		—	1.0	—	V
Current Sense Amp						
V_{GAIN}	GAIN ($\Delta V_{GS}/\Delta V_{OUT}$)		—	100	—	dB
V_{CS}	Current Limit Threshold	$(V_{IN} - V_{SNS}) @ I_{MAX}$	40	53	75	mV
I_{SC}	Short Circuit Current		—	46	—	mA
K	KFactor		—	0.46	—	A/A
MODE						
V_{TH}	Mode Threshold		—	V_{REG}	—	V
V_{OL}	Mode Low Voltage	$I_{SINK} = 10\text{mA}$, $V_{OUT} = 3.5V$	—	—	400	mV
I_{LK}	Mode Leakage Current	$V_{MODE} = 5.5V$, $I_O = 0\text{mA}$, MODE = Constant Voltage	—	—	+1	μA
SHDN						
V_{IH}	\overline{SHDN} High Threshold		40	—	—	% V_{DD}
V_{IL}	\overline{SHDN} Low Threshold		—	—	25	% V_{DD}
I_{LK}	\overline{SHDN} Leakage Current	$V_{SHDN} = 0V$ to 5V	—	—	+1	μA
I_{MON}						
$\frac{\Delta V_{IMON}}{\Delta(V_{IN} - V_{SNS})}$	Current Sense Gain	$V_O = 0V$ to 3.5V, $R_L > 20\text{k}\Omega$	—	26	—	V/V

Notes: 1. Where $V_{OUT} = 1\%$ from Nominal, continuous current.

PIN DESCRIPTION

Pin No. 8-Pin MSOP	Symbol	Type	Description
1	$\overline{\text{SHDN}}$	Signal Input	Shutdown Input
2	GND	Power	System Ground
3	MODE	Signal Output	Charge Mode Indicator
4	I_{MON}	Voltage Output	Buffered Copy of Current Sense Resistor Drop
5	V_{OUT}	Voltage Input	Charger DC Output Voltage Sense
6	V_{DRV}	Signal Output	Gate Drive to External MOSFET
7	V_{SNS}	Signal Input	Current Sense Voltage Input
8	V_{IN}	Power	Charger DC Input Voltage

I/O DESCRIPTION

SHDN: When $\overline{\text{SHDN}}$ is low, V_{DRV} is pulled high to V_{IN} and the charge is interrupted.

GND: Connect to the battery's negative terminal. See Layout Guidelines for information on system grounding.

V_{OUT} : Battery positive terminal and charger regulated output voltage. This pin is connected to the external PMOS drain and directly to the load for optimal regulation. V_{OUT} pin draws typically $1\mu\text{A}$ from the battery when V_{IN} power is removed. Requires a Bypass capacitor.

MODE: Charge Status Indicator. Mode is an open-drain, N-channel MOSFET capable of sinking 20mA for an LED status indication of charger in current limited mode. LED is off in current-voltage mode.

V_{DRV} : Gate drive output for the external PMOS pass device.

I_{MON} : Battery Charge current profile. This output is an amplified copy of the voltage drop across the current sense resistor. It can be used as input to an A/D converter to provide the controller with information about the charge current profile.

V_{IN} : Charger power supply input (+6V absolute max.). Bypass to GND with a capacitor.

V_{SNS} : Battery charge current sense voltage feedback. This voltage is developed across a small value precision resistor that is in series with the battery.

FUNCTIONAL DESCRIPTION

The TC3827 controller only requires a P-channel power MOSFET and two small capacitors to perform as an inexpensive Li-Ion battery charger. The TC3827 controller drives an external PMOS to provide a regulated output current to charge the battery. Initially, current limited charging occurs until a pre-specified battery voltage is measured at the V_{OUT} pin. It then switches to constant-voltage mode. During constant-voltage mode the TC3827 works like a linear regulator, holding the output voltage within the specified accuracy. The charger output is sensed at the V_{OUT} pin. The charging current follows the foldback characteristic as shown in Figure 2. The sense resistor sets the maximum charging current, I_{MAX} . The voltage drop across the current sense resistor is sensed at the V_{SNS} input. An amplified copy of this sense voltage is provided as output on the current monitor pin (I_{MON}). When the battery is deeply discharged to a minimum voltage level, or if the battery is shorted, the current sense circuit folds back the charge current to limit the power dissipation of the PMOS. Both the V_{IN} and V_{OUT} pins

of the IC need a suitable bypass capacitor. The TC3827 also has a logic-level shutdown input, $\overline{\text{SHDN}}$, which may be connected to the input voltage to enable the IC. Pulling it "low" or to ground will disable the PMOS drive (V_{DRV} pulled up to V_{IN} voltage). Also, a charger mode pin (MODE) is provided to drive an optional LED for a visual indication of current limited mode operation. LED will be turned off in constant voltage mode operation.

TC3827

APPLICATIONS INFORMATION

A typical Li-Ion cell should be charged at a controlled current until it reaches 4.1V or 4.2V (depending on the type of cell), then charged at this voltage. The TC3827 is designed to offer the maximum integration and function with a small application circuit. The only necessary external components are a PMOS, two small capacitors, and an R_{SENSE} .

The charge current profile can be monitored using the voltage signal at I_{MON} . The use of an LED as a status indicator is optional. The application circuit is shown in Figure 1.

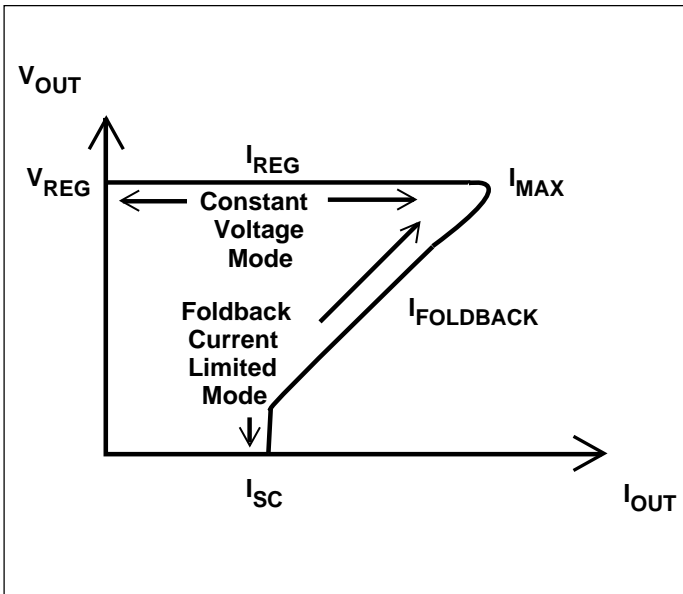

Figure 2. TC3827 Charging Characteristic

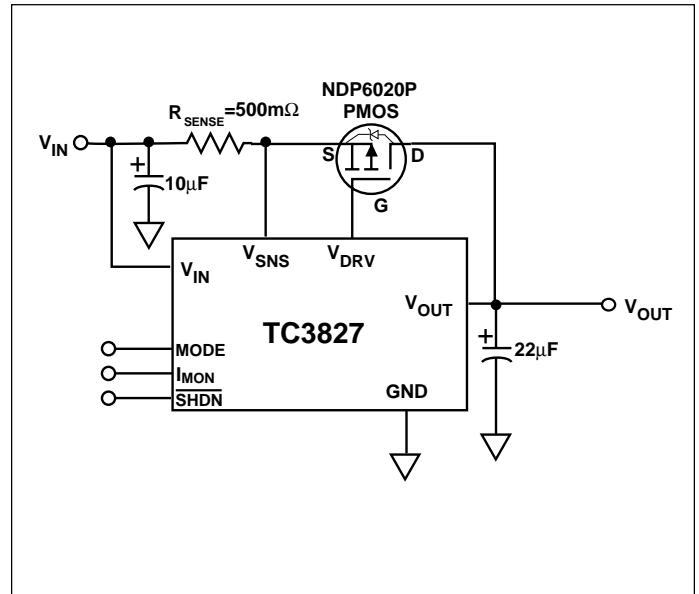

Figure 3. TC3827 Test Circuit

SELECTING EXTERNAL COMPONENTS

Power Supply Input

In most applications, this will be a small “wall cube” switching converter with an output voltage limit range of 5V to 6V.

P-Channel Pass Device

The PMOS is used to regulate current from the source into the Li-Ion cell. Specifications to consider when choosing an appropriate PMOS are the minimum drain-source breakdown voltage, the minimum turn-on threshold voltage (V_{GSTH}), drain current and power-dissipation capabilities.

Bypass Capacitors

Bypass V_{IN} with a capacitor value of at least $10\mu F$. Bypass V_{OUT} with a capacitor value of at least $1\mu F$.

CHARGER MODES DESCRIPTION

Initiating a Charge Cycle

The TC3827 initiates a charge upon toggling the shut-down pin high, insertion of the battery or application of an external power source. The TC3827 provides a foldback current limited charge where an external current sense resistor sets I_{MAX} . The voltage drop across the current sense resistor is applied to the $V_{IN}-V_{SNS}$ pins and presented to the current limited control-loop. The current loop will protect a deeply discharged (or shorted) battery by folding back the current limited charge, and reduces the power dissipation in PMOS.

Current Limited, Constant-voltage Charge Cycle

The TC3827 begins to charge the Li-Ion cell by turning on the external PMOS. The charge continues until the battery voltage rises to the lithium-ion cell voltage of 4.2V or 4.1V (depending on type of cell). As the battery voltage reaches the regulated output voltage, the internal feedback

control loop changes from current limiting to voltage regulation. If an external micro-controller determines battery conditions are unsafe for charge it can toggle the shutdown pin low and interrupt the charge cycle. Otherwise, once the pre-determined cell voltage is reached the TC3827 shifts into a constant-voltage mode (linear regulation) and a variable charge current is applied as required to maintain the battery cell voltage to within 1% accuracy of the cell voltage set-point.

I_{MON} – Charge Current Status

The I_{MON} pin provides an output voltage that is proportional to the battery charging current. It is an amplified version of the sense resistor voltage drop that the current loop uses to control the PMOS device. This voltage signal can be applied to the input of an A/D Converter and used by a controller to display information about the state of the battery or charge current profile.

MODE – Charge Mode Status LED

The MODE pin indicates the battery charging mode. An LED can be connected to the MODE for a visible indicator. Alternatively, a pull-up resistor (typically 100kΩ) from the interfacing logic supply to MODE provides a logic-level output. The MODE pin will toggle LOW and the LED will illuminate when the charger is in the current limited mode. The MODE pin toggles to a high impedance state and the LED will be off during constant-voltage mode charging or if the battery is not connected. The MODE pin toggles at a V_{OUT} of V_{REG}, typically.

APPLICATION CIRCUIT DESIGN

Due to the low efficiency of Linear Regulator Charging, the most important factors are thermal design and cost, which is a direct function of the input voltage, output current and thermal impedance between the PMOS and the ambient cooling air. The worst-case situation is when the battery is shorted since the PMOS has to dissipate the maximum power. A tradeoff must be made between the charge current, cost and thermal requirements of the charger. Higher current requires a larger PMOS with more effective heat dissipation leading to a more expensive design. Lowering the charge current reduces cost by lowering the size of the PMOS, possibly allowing a smaller package such as 6-Pin SOT. The following designs consider both options.

Higher Current Option

The current sense resistor for the circuit shown in Figure 1 is calculated by: $R_{SENSE} = V_{CS} / I_{MAX}$.

Where V_{CS} is the current limit threshold voltage of 40mV to 75mV, 50mV typical. If I_{MAX} = 1A is desired, R_{SENSE} = 50mΩ.

Pre-regulated Input Voltage (5V ± 0%)

For this application, the required θ_{JA} thermal impedance is calculated as follows:

if: the PMOS data sheet allows a max junction temperature of T_{JMAX} = 150°C,
then: at 50°C ambient with convection cooling, the maximum allowed junction temperature rise is:

$$T_{JMAX} - T_{AMAX} = 150^{\circ}\text{C} - 50^{\circ}\text{C} = 100^{\circ}\text{C}.$$

$$\theta_{JA} = \Delta T / (I_{O} \times k \times V_{IN}) = 100 / (1 \times 0.46 \times 5.5) = 39.5^{\circ}\text{C/W}$$

This k factor is: $k = I_{SC} / I_{MAX} \approx 0.46$.

This thermal impedance can be realized using the transistor shown in Figure 1 when routed to a heat sink. The θ_{SA} or thermal impedance of a suitable heatsink is calculated below:

$$\theta_{SA} \leq (\theta_{JA} - \theta_{JC} - \theta_{CS}) = 39.5 - 2.5 - 0.3 = 36.7^{\circ}\text{C/W}$$

Where the θ_{JC}, or junction-to-case thermal impedance is for the PMOS from the PMOS data sheet. A low cost heatsink is Thermalloy type PF430, with a θ_{SA} = +25.3°C/W.

TC3827

Lower Current Option

Preregulated Input Voltage (5V +/- 10%)

If lower charging current is allowed, the Θ_{JA} value can be increased, and the system cost decreased. This is accomplished by using a FDC638P PMOS, for example, in a 6-Pin SOT package mounted on a small 1in x 1in area of 2oz Cu on FR-4 board. This provides a convection cooled thermal impedance of $\Theta_{JA} = +78^{\circ}\text{C}/\text{W}$. Allowing a maximum FET junction temperature of $+150^{\circ}\text{C}$, at $+50^{\circ}\text{C}$ ambient, with convection cooling the maximum allowed heat rise is:

$$150^{\circ}\text{C} - 50^{\circ}\text{C} = 100^{\circ}\text{C}.$$

The maximum short circuit current, I_{SC} , is found as:

$$I_{SC} = \Delta T / (\Theta_{JA} \times V_{IN}) = 100 / (78 \times 5.5) = 0.23\text{A}$$

Thus the maximum charging current, I_{MAX} , is:

$$I_{MAX} = I_{SC} / k = 0.51\text{A}$$

The current sense resistor for this application is then:

$$R_{SENSE} = V_{CS} / I_{MAX} = 0.05 / 0.51 = 98\text{m}\Omega \approx 100\text{m}\Omega$$

FET Selection

The type and size of the pass transistor is determined by the threshold voltage, input-output voltage differential and load current. The selected PMOS must satisfy the physical and thermal design requirements. To ensure that the maximum V_{GS} provided by the controller will turn on the FET at worst case conditions, (i.e., temperature and manufacturing tolerances) the maximum available V_{GS} must be determined. Maximum V_{GS} is calculated as follows:

$$V_{GSMAX} = V_{IN} - (I_{MAX} \times R_{SENSE}) - V_{DRVMAX}$$

For example:

$$V_{IN} = 5\text{V}, \text{ and } I_{MAX} = 1\text{A},$$

$$V_{GSMAX} = 5\text{V} - (1\text{A} \times 50\text{m}\Omega) - 1\text{V} = 3.95\text{V}$$

The difference between V_{IN} and V_O (V_{DS}) must exceed the voltage drop due to the sense resistor plus the ON-resistance of the PMOS at the maximum charge current.

$$V_{DS} \leq V_{IN} - V_O - V_{CS} = 5\text{V} - 4.2\text{V} - 0.075\text{V} = 0.725\text{V}$$

The maximum $R_{DS(ON)}$ required at the available gate drive (V_{DR}) and Drain-to-Source voltage (V_{DS}) is:

$$R_{DS(ON)} = V_{DS} / I_{MAX} \leq 0.725\text{V} / 1\text{A} = 725\text{m}\Omega$$

The selected PMOS must satisfy these criteria.

External Capacitors

The TC3827 is stable with or without a battery load, and virtually any good quality output filter capacitors can be used, independent of the capacitor's minimum ESR (Effective Series Resistance) value. The actual value of the capacitor and its associated ESR depends on the g_m and capacitance of the external PMOS device. A $22\mu\text{F}$ tantalum or aluminum electrolytic capacitor at the output is sufficient to ensure stability for up to a 10A output current.

Shutdown Mode

Applying a logic high signal to the $\overline{\text{SHDN}}$ pin or tying it to the input pin will enable the output. Pulling this pin low or tying it to ground will disable the output. In shutdown mode, the controller's quiescent current is reduced to typically $1\mu\text{A}$.

Short Circuit Protection

The PMOS is protected during short circuit conditions with a foldback type of current limiting that reduces the power dissipation.

Current Sense Resistor

The current limit sense resistor, R_{SENSE} , is calculated previously. Proper de-rating is advised to select the power dissipation rating of the resistor. The simplest and cheapest sense resistor for high current applications, is a PCB trace. However, the temperature dependence of the copper trace and the thickness tolerances of the trace must be considered in the design.

Copper's Tempco, in conjunction with the proportional-to-absolute temperature ($\pm 0.3\%$) current limit voltage, can provide an accurate current limit. Alternately, an appropriate sense resistor, such as surface mount sense resistors, available from KRL, can be used.

PCB Layout Issues

For optimum voltage regulation, place the load as close as possible to the device's V_{OUT} and GND pins. It is recommended to use dedicated PCB traces to connect the PMOS drain to the positive terminal and V_{SS} to the negative terminal of the load to avoid voltage drops along the high current carrying PCB traces.

If the PCB layout is used as a heatsink, adding many vias around the power FET helps conduct more heat from the FET to the back-plane of the PCB, thus reducing the maximum FET junction temperature.

TYPICAL CURVES

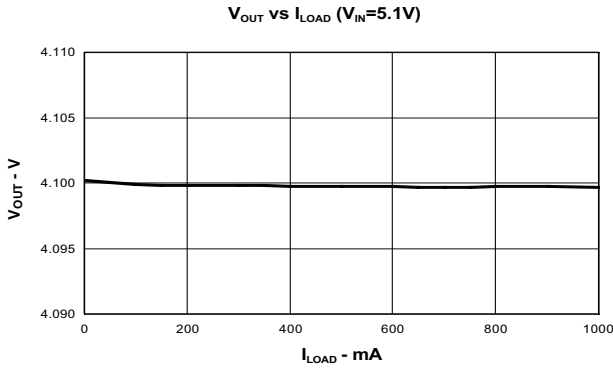

Figure. 4

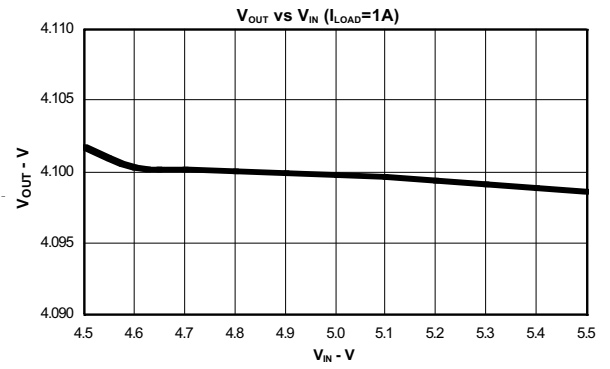

Figure. 5

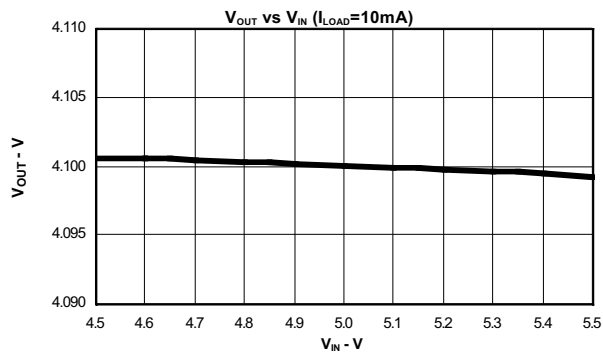

Figure. 6

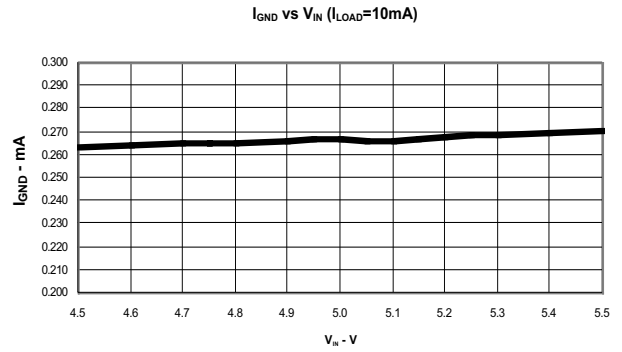

Figure. 7

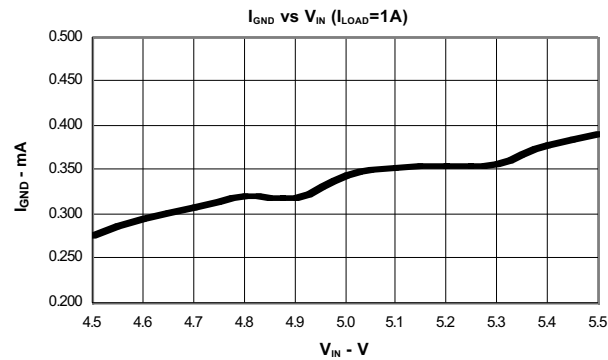

Figure. 8

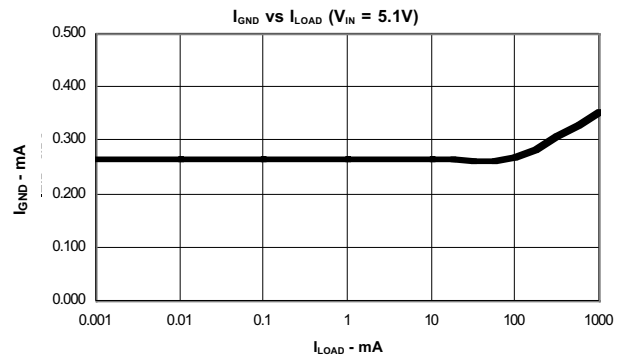

Figure. 9

TYPICAL CURVES (CONT.)

TC3827

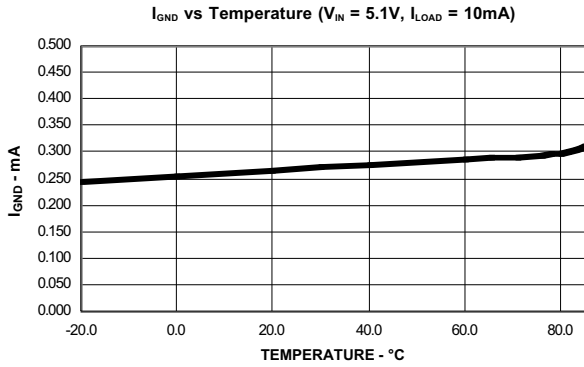

Figure. 10

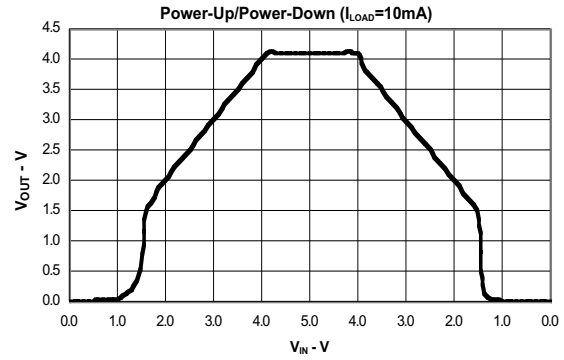

Figure. 11

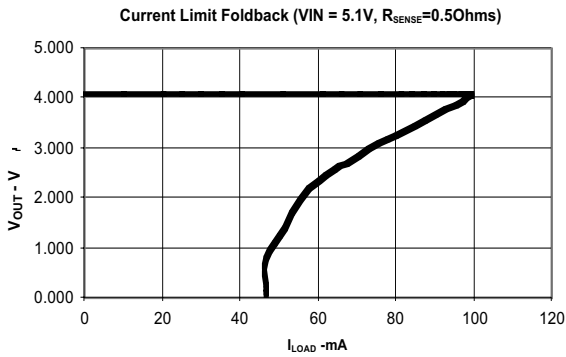

Figure. 12

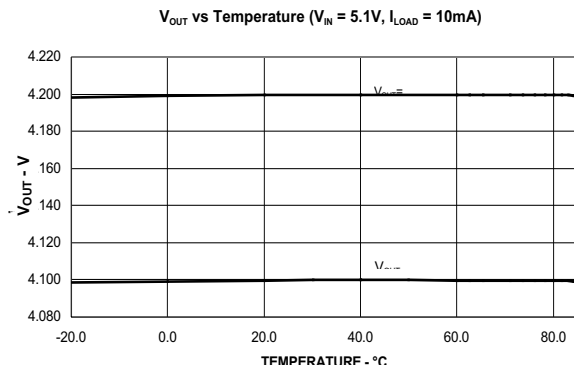

Figure. 13

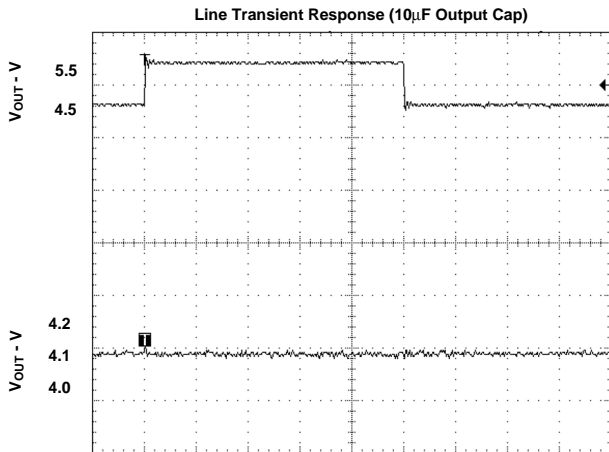
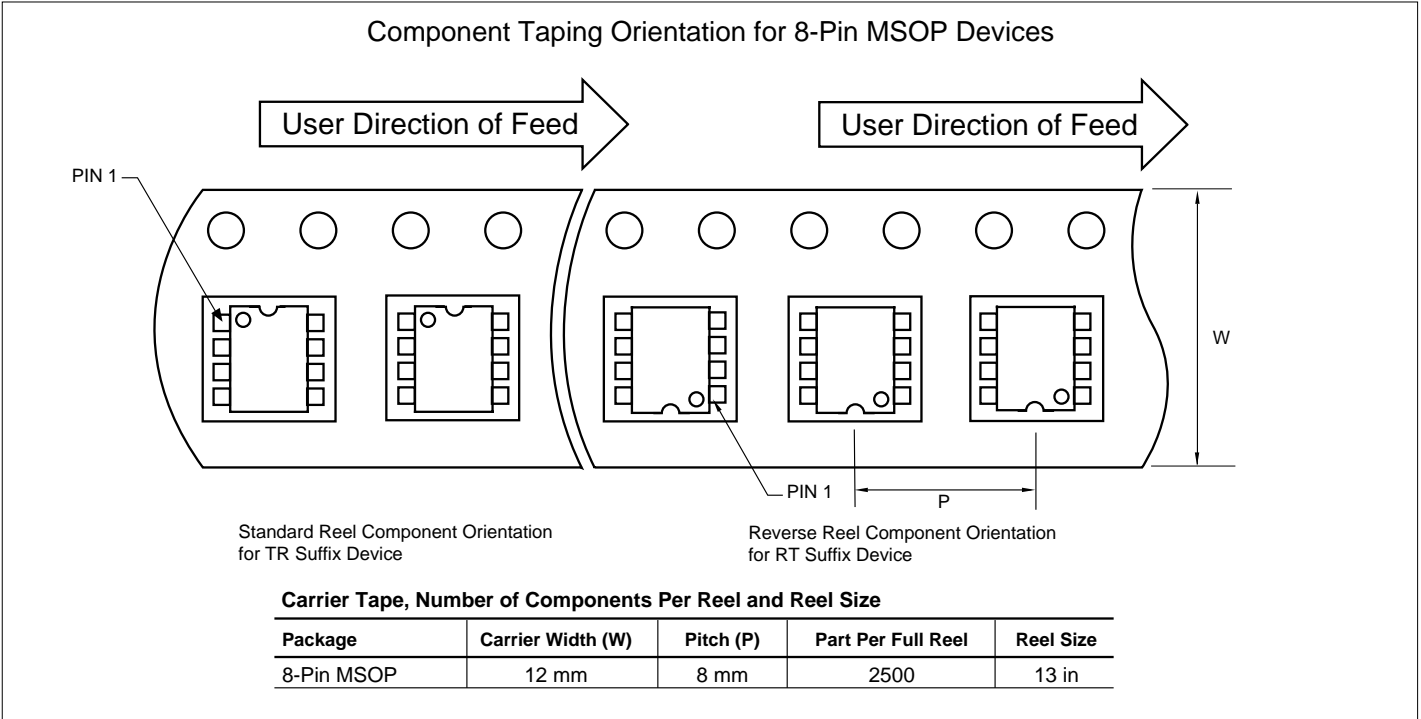
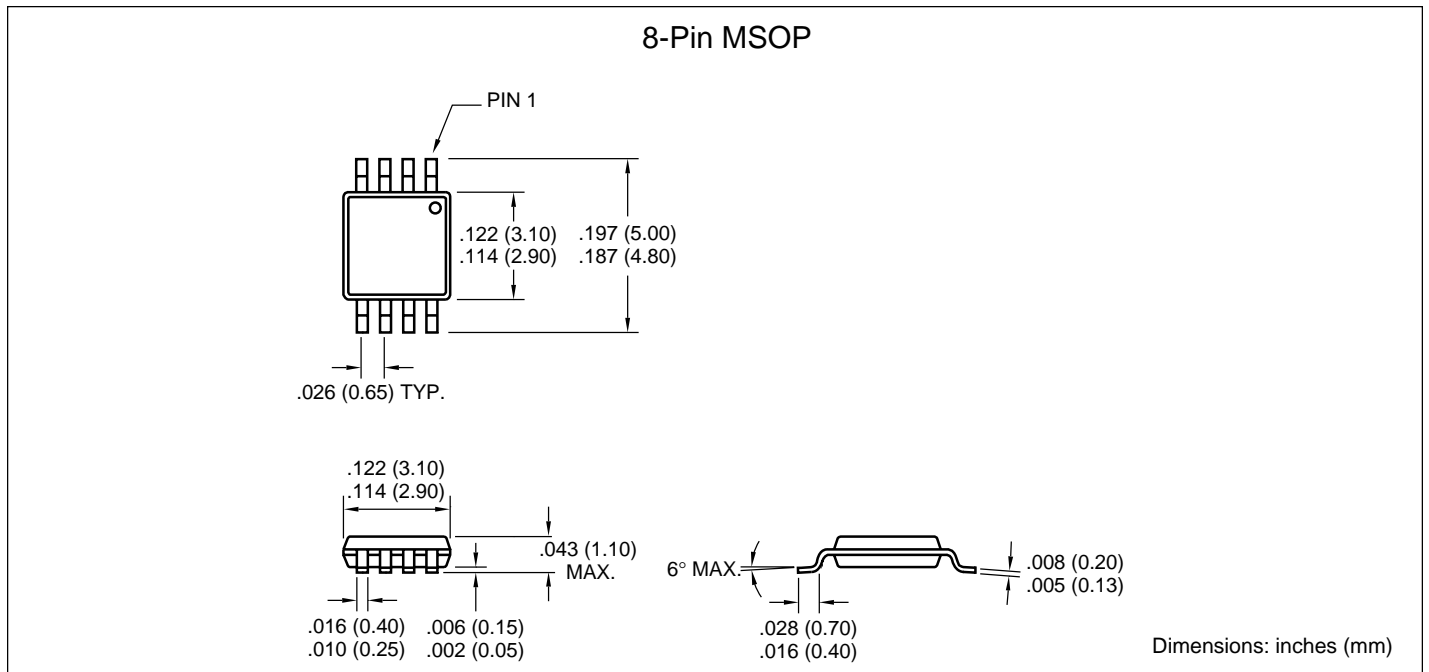

Figure. 14

TAPING FORM



PACKAGE DIMENSIONS





WORLDWIDE SALES AND SERVICE

AMERICAS

Corporate Office

2355 West Chandler Blvd.
Chandler, AZ 85224-6199
Tel: 480-792-7200 Fax: 480-792-7277
Technical Support: 480-792-7627
Web Address: <http://www.microchip.com>

Rocky Mountain

2355 West Chandler Blvd.
Chandler, AZ 85224-6199
Tel: 480-792-7966 Fax: 480-792-7456

Atlanta

500 Sugar Mill Road, Suite 200B
Atlanta, GA 30350
Tel: 770-640-0034 Fax: 770-640-0307

Austin

Analog Product Sales
8303 MoPac Expressway North
Suite A-201
Austin, TX 78759
Tel: 512-345-2030 Fax: 512-345-6085

Boston

2 Lan Drive, Suite 120
Westford, MA 01886
Tel: 978-692-3848 Fax: 978-692-3821

Boston

Analog Product Sales
Unit A-8-1 Millbrook Tarry Condominium
97 Lowell Road
Concord, MA 01742
Tel: 978-371-6400 Fax: 978-371-0050

Chicago

333 Pierce Road, Suite 180
Itasca, IL 60143
Tel: 630-285-0071 Fax: 630-285-0075

Dallas

4570 Westgrove Drive, Suite 160
Addison, TX 75001
Tel: 972-818-7423 Fax: 972-818-2924

Dayton

Two Prestige Place, Suite 130
Miamisburg, OH 45342
Tel: 937-291-1654 Fax: 937-291-9175

Detroit

Tri-Atria Office Building
32255 Northwestern Highway, Suite 190
Farmington Hills, MI 48334
Tel: 248-538-2250 Fax: 248-538-2260

Los Angeles

18201 Von Karman, Suite 1090
Irvine, CA 92612
Tel: 949-263-1888 Fax: 949-263-1338

Mountain View

Analog Product Sales
1300 Terra Bella Avenue
Mountain View, CA 94043-1836
Tel: 650-968-9241 Fax: 650-967-1590

New York

150 Motor Parkway, Suite 202
Hauppauge, NY 11788
Tel: 631-273-5305 Fax: 631-273-5335

San Jose

Microchip Technology Inc.
2107 North First Street, Suite 590
San Jose, CA 95131
Tel: 408-436-7950 Fax: 408-436-7955

Toronto

6285 Northam Drive, Suite 108
Mississauga, Ontario L4V 1X5, Canada
Tel: 905-673-0699 Fax: 905-673-6509

ASIA/PACIFIC

China - Beijing

Microchip Technology Beijing Office
Unit 915
New China Hong Kong Manhattan Bldg.
No. 6 Chaoyangmen Beidajie
Beijing, 100027, No. China
Tel: 86-10-85282100 Fax: 86-10-85282104

China - Shanghai

Microchip Technology Shanghai Office
Room 701, Bldg. B
Far East International Plaza
No. 317 Xian Xia Road
Shanghai, 200051
Tel: 86-21-6275-5700 Fax: 86-21-6275-5060

Hong Kong

Microchip Asia Pacific
RM 2101, Tower 2, Metroplaza
223 Hing Fong Road
Kwai Fong, N.T., Hong Kong
Tel: 852-2401-1200 Fax: 852-2401-3431

India

Microchip Technology Inc.
India Liaison Office
Divyasree Chambers
1 Floor, Wing A (A3/A4)
No. 11, OisShaughnessey Road
Bangalore, 560 025, India
Tel: 91-80-2290061 Fax: 91-80-2290062

Japan

Microchip Technology Intl. Inc.
Benex S-1 6F
3-18-20, Shinyokohama
Kohoku-Ku, Yokohama-shi
Kanagawa, 222-0033, Japan
Tel: 81-45-471- 6166 Fax: 81-45-471-6122

Korea

Microchip Technology Korea
168-1, Youngbo Bldg. 3 Floor
Samsung-Dong, Kangnam-Ku
Seoul, Korea
Tel: 82-2-554-7200 Fax: 82-2-558-5934

ASIA/PACIFIC (continued)

Singapore

Microchip Technology Singapore Pte Ltd.
200 Middle Road
#07-02 Prime Centre
Singapore, 188980
Tel: 65-334-8870 Fax: 65-334-8850

Taiwan

Microchip Technology Taiwan
11F-3, No. 207
Tung Hua North Road
Taipei, 105, Taiwan
Tel: 886-2-2717-7175 Fax: 886-2-2545-0139

EUROPE

Australia

Microchip Technology Australia Pty Ltd
Suite 22, 41 Rawson Street
Epping 2121, NSW
Australia
Tel: 61-2-9868-6733 Fax: 61-2-9868-6755

Denmark

Microchip Technology Denmark ApS
Regus Business Centre
Lautrup høj 1-3
Ballerup DK-2750 Denmark
Tel: 45 4420 9895 Fax: 45 4420 9910

France

Arizona Microchip Technology SARM
Parc d'Activite du Moulin de Massy
43 Rue du Saule Trapu
Batiment A - 1er Etage
91300 Massy, France
Tel: 33-1-69-53-63-20 Fax: 33-1-69-30-90-79

Germany

Arizona Microchip Technology GmbH
Gustav-Heinemann Ring 125
D-81739 Munich, Germany
Tel: 49-89-627-144 0 Fax: 49-89-627-144-44

Germany

Analog Product Sales
Lochhamer Strasse 13
D-82152 Martinsried, Germany
Tel: 49-89-895650-0 Fax: 49-89-895650-22

Italy

Arizona Microchip Technology SRL
Centro Direzionale Colleoni
Palazzo Taurus 1 V. Le Colleoni 1
20041 Agrate Brianza
Milan, Italy
Tel: 39-039-65791-1 Fax: 39-039-6899883

United Kingdom

Arizona Microchip Technology Ltd.
505 Eskdale Road
Winnersh Triangle
Wokingham
Berkshire, England RG41 5TU
Tel: 44 118 921 5869 Fax: 44-118 921-5820

All rights reserved. © 2001 Microchip Technology Incorporated. Printed in the USA. 1/01  Printed on recycled paper.

01/09/01

Information contained in this publication regarding device applications and the like is intended through suggestion only and may be superseded by updates. It is your responsibility to ensure that your application meets with your specifications. No representation or warranty is given and no liability is assumed by Microchip Technology Incorporated with respect to the accuracy or use of such information, or infringement of patents or other intellectual property rights arising from such use or otherwise. Use of Microchip's products as critical components in life support systems is not authorized except with express written approval by Microchip. No licenses are conveyed, implicitly or otherwise, except as maybe explicitly expressed herein, under any intellectual property rights. The Microchip logo and name are registered trademarks of Microchip Technology Inc. in the U.S.A. and other countries. All rights reserved. All other trademarks mentioned herein are the property of their respective companies.