

C²MOS DIGITAL INTEGRATED CIRCUIT
SILICON MONOLITHIC

TC40H375P/F

TC40H375 4-BIT BISTABLE LATCH

The TC40H375 is a 4-bit latch having ENABLE input terminal common in two circuits.

When ENABLE input is at "H" level, DATA input is transmitted to output as it is. If ENABLE input is transferred from "H" level to "L" level, latch holds input DATA immediately before falling. When ENABLE input is at "L" level, output does not change even if input DATA changes.

MAXIMUM RATINGS

CHARACTERISTIC	SYMBOL	RATING	UNIT
Supply Voltage	V _{DD}	V _{SS} -0.5 ~ V _{SS} +10	V
Input Voltage	V _{IN}	V _{SS} -0.5 ~ V _{DD} +0.5	V
Output Voltage	V _{OUT}	V _{SS} -0.5 ~ V _{DD} +0.5	V
Input Current	I _{IN}	±10	mA
Power Dissipation	P _D	300(DIP)/180(MFP)	mW
Storage Temperature	T _{stg}	-65 ~ 150	°C
Lead Temp./Time	T _{sol}	260°C • 10 sec	

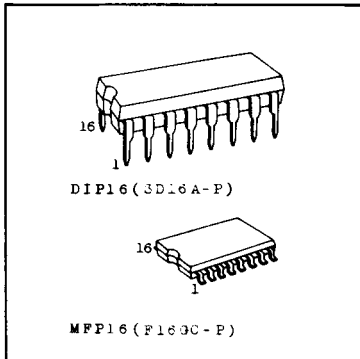

PIN CONNECTION

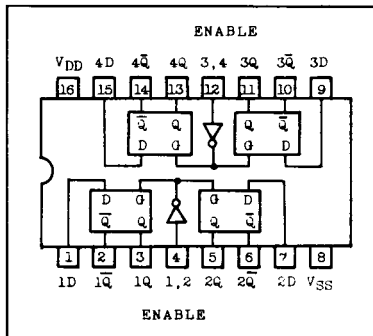

TRUTH TABLE

INPUT		OUTPUT	
DATA	ENABLE	Q	Q ⁻
L	H	L	H
H	H	H	L
X	L	No Change	

X = Don't Care

LOGIC DIAGRAM

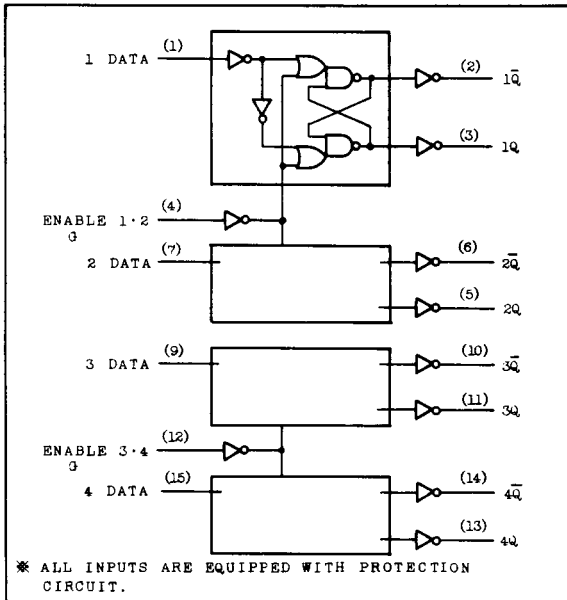

TC40H375P/F

RECOMMENDED OPERATING CONDITIONS ($V_{SS}=0.0V$)

CHARACTERISTIC	SYMBOL	TEST CONDITION	MIN.	TYP.	MAX.	UNIT
Supply Voltage	V_{DD}	-	2.0	-	8.0	V
Input Voltage	V_{IN}	-	0	-	V_{DD}	V
Operating Temperature	T_{opr}	-	-40	-	85	°C

ELECTRICAL CHARACTERISTICS ($V_{SS}=0.0V$)

CHARACTERISTIC	SYMBOL	TEST CONDITION	V_{DD} (V)	-40°C		25°C			85°C		UNIT
				MIN.	MAX.	MIN.	TYP.	MAX.	MIN.	MAX.	
High Level Output Voltage	V_{OH}	$ I_{OUT} < 1\mu A$ $V_{IN}=V_{SS}, V_{DD}$	5	4.95	-	4.95	5.0	-	4.95	-	V
Low Level Output Voltage	V_{OL}	$ I_{OUT} < 1\mu A$ $V_{IN}=V_{SS}, V_{DD}$	5	-	0.05	-	0.0	0.05	-	0.05	V
High Level Output Current	I_{OH}	$V_{OH}=4.6V$ $V_{IN}=V_{SS}, V_{DD}$	5	-0.52	-	-0.44	-	-	-0.36	-	mA
Low Level Output Current	I_{OL}	$V_{OL}=0.4V$ $V_{IN}=V_{SS}, V_{DD}$	5	1.4	-	1.1	-	-	0.8	-	mA
Input Voltage	High Level V_{IH}	$ I_{OUT} < 1\mu A$ $V_{OUT}=0.5V$	5	4.0	-	4.0	-	-	4.0	-	V
	Low Level V_{IL}		5	-	1.0	-	-	1.0	-	1.0	
Input Current "H" Level	I_{IH}	$V_{IH}=8.0V$	8	-	0.3	-	10^{-5}	0.3	-	1.0	μA
Input Current "L" Level	I_{IL}	$V_{IL}=0.0V$	8	-	-0.3	-	-10^{-5}	-0.3	-	-1.0	μA
Quiescent Supply Current	I_{DD}	$*V_{IN}=V_{SS}, V_{DD}$	5	-	12.5	-	10^{-3}	12.5	-	75	μA

* All valid input combinations.

SWITCHING CHARACTERISTICS ($T_a=25^\circ C$, $V_{DD}=5V$, $C_L=15pF$)

CHARACTERISTIC	SYMBOL	TEST CONDITION	MIN.	TYP.	MAX.	UNIT
Output Rise Time	t_{or}		-	18	35	ns
Output Fall Time	t_{of}		-	15	30	
Propagation Delay Time	Low-High Level t_{pLH}	DATA - Q, \bar{Q}	-	43	65	ns
	High-Low Level t_{pHL}		-	35	53	
Propagation Delay Time	Low-High Level t_{pLH}	ENABLE - Q, \bar{Q}	-	43	65	ns
	High-Low Level t_{pHL}		-	35	53	
Minimum Enable Pulse Width	t_w		-	40	60	ns
Minimum Hold Time	t_{hold}		-	-	6	ns
Minimum Set-up Time	t_{set-up}		-	25	44	ns
Input Capacitance	C_{IN}		-	5		pF

TC40H375P/F

SWITCHING TIME TEST CIRCUIT AND WAVEFORM

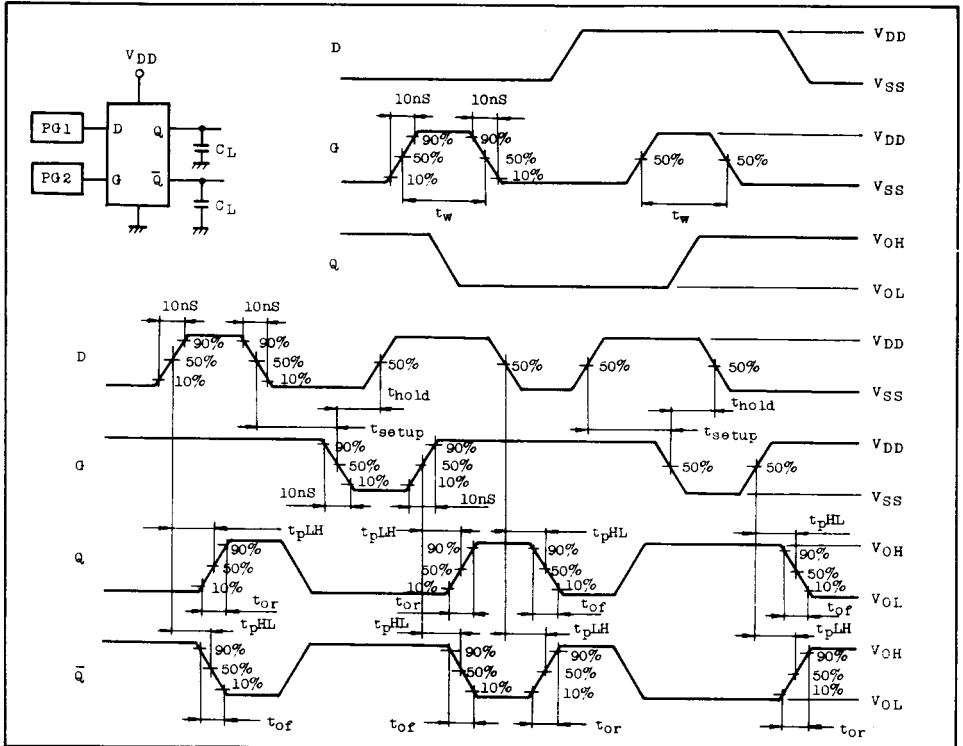

$t_{pd} - V_{DD}$

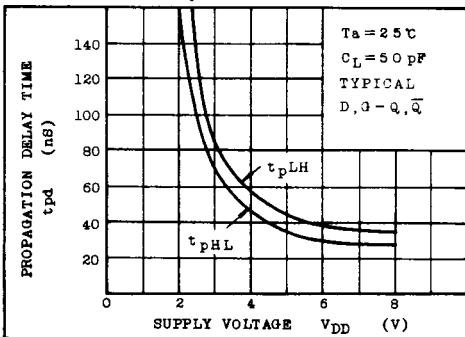

$t_{pd} - C_L$

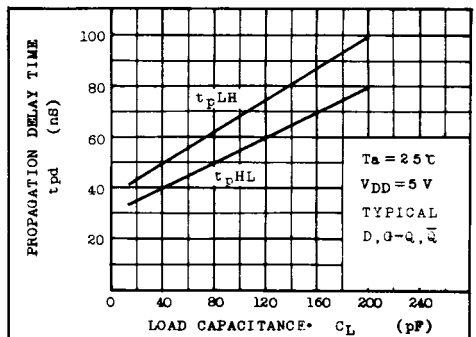

TC40H375P/F

