

TOSHIBA

TC55V1664BJ/BFT-10,-12,-15

TENTATIVE TOSHIBA MOS DIGITAL INTEGRATED CIRCUIT SILICON GATE CMOS

65,536-WORD BY 16-BIT CMOS STATIC RAM

DESCRIPTION

The TC55V1664BJ/BFT is a 1,048,576 bits high speed static random access memory organized as 65,536 words by 16 bits using CMOS technology, and operated from a single 3.3V supply. Toshiba's CMOS technology and advanced circuit form provide high speed feature.

The TC55V1664BJ/BFT has low power feature with device control using chip enable (\overline{CE}), and has output enable (\overline{OE}) for fast memory access. Also it allows lower and upper byte access by data byte control (\overline{LB} , \overline{UB}). The TC55V1664BJ/BFT is suitable for use in cache memory where high speed is required, and high speed strage. All inputs and outputs are directly LVTTTL compatible.

The TC55V1664BJ/BFT is packaged in 44-pin plastic SOJ and TSOP with 400 mil width for high density surface assembly.

FEATURES

- Fast access time :

TC55V1664BJ/BFT-10	10ns (MAX)
TC55V1664BJ/BFT-12	12ns (MAX)
TC55V1664BJ/BFT-15	15ns (MAX)
- Low power dissipation

Cycle Time	10	12	15	20	ns
Operation (MAX)	230	190	170	150	mA
Standby :	2mA (MAX)				
- 3.3V single power supply : $3.3V \pm 0.3V$
- Fully static operation
- All Inputs and Outputs : LVTTTL compatible
- Output buffer control : \overline{OE}
- Data byte control
 \overline{LB} (I/O1 to I/O8), \overline{UB} (I/O9 to I/O16)
- Package:
 SOJ44-P-400-1.27 (BJ) (Weight : 1.64gm Typ)
 TSOP II 44-P-400-0.80 (BFT) (Weight : 0.45gm Typ)

PIN CONNECTION

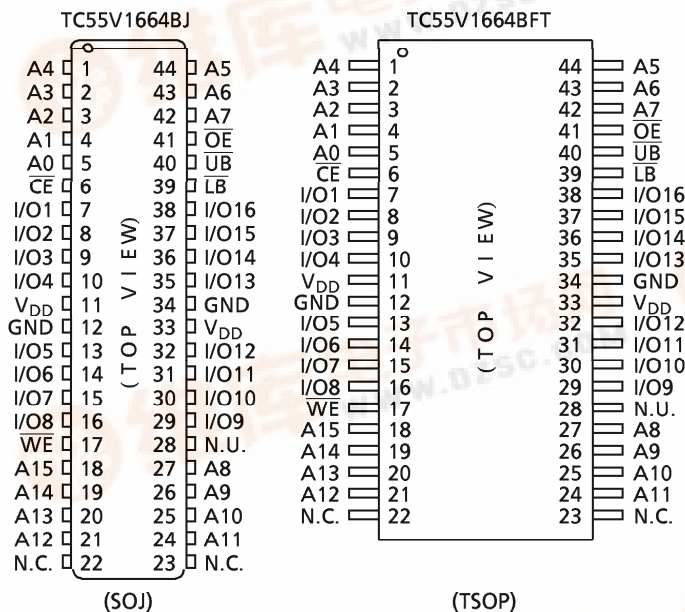

PIN NAMES

A0 to A15	Address Inputs
I/O1 to I/O16	Data Inputs/Outputs
\overline{CE}	Chip Enable Input
\overline{WE}	Write Enable Input
\overline{OE}	Output Enable Input
\overline{LB} , \overline{UB}	Data Byte Control Inputs
V_{DD}	Power (+ 3.3V)
GND	Ground
N.C.	No Connection
N.U.	Not Usable (Input)

961001EBA1

- TOSHIBA is continually working to improve the quality and the reliability of its products. Nevertheless, semiconductor devices in general can malfunction or fail due to their inherent electrical sensitivity and vulnerability to physical stress. It is the responsibility of the buyer, when utilizing TOSHIBA products, to observe standards of safety, and to avoid situations in which a malfunction or failure of a TOSHIBA product could cause loss of human life, bodily injury or damage to property. In developing your designs, please ensure that TOSHIBA products are used within specified operating ranges as set forth in the most recent products specifications. Also, please keep in mind the precautions and conditions set forth in the TOSHIBA Semiconductor Reliability Handbook.
- The products described in this document are subject to foreign exchange and foreign trade control laws.
- The information contained herein is presented only as a guide for the applications of our products. No responsibility is assumed by TOSHIBA CORPORATION for any infringements of intellectual property or other rights of the third parties which may result from its use. No license is granted by implication or otherwise under any intellectual property or other rights of TOSHIBA CORPORATION or others.
- The information contained herein is subject to change without notice.

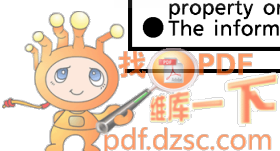

BLOCK DIAGRAM

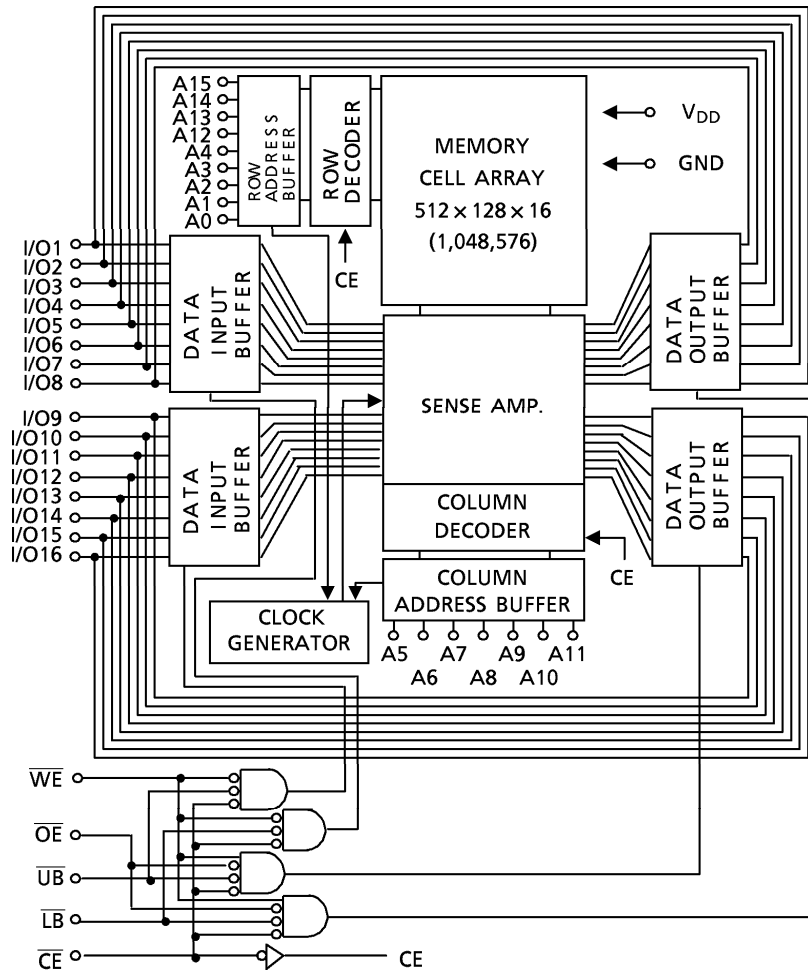

MAXIMUM RATINGS

SYMBOL	RATING	VALUE	UNIT
V _{DD}	Power Supply Voltage	-0.5 to 4.6	V
V _{IN}	Input Terminal Voltage	-0.5* to 4.6	V
V _{I/O}	Input/Output Terminal Voltage	-0.5* to V _{DD} + 0.5**	V
P _D	Power Dissipation	0.95	W
T _{solder}	Soldering Temperature (10s)	260	°C
T _{strg}	Storage Temperature	-65 to 150	°C
T _{opr}	Operating Temperature	-10 to 85	°C

* : -1.5V with a pulse width of 20% · t_{RC} min (4ns max)

** : V_{DD} + 1.5V with a pulse width of 20% · t_{RC} min (4ns max)

DC RECOMMENDED OPERATING CONDITIONS (Ta = 0° to 70°C)

SYMBOL	PARAMETER	MIN	TYP	MAX	UNIT
V _{DD}	Power Supply Voltage	3.0	3.3	3.6	V
V _{IH}	Input High Voltage	2.0	-	V _{DD} + 0.3**	V
V _{IL}	Input Low Voltage	-0.3*	-	0.8	V

* : -1.0V with a pulse width of 20% · t_{RC} min (4ns max)

** : V_{DD} + 1.0V with a pulse width of 20% · t_{RC} min (4ns max)

DC and OPERATING CHARACTERISTICS (Ta = 0° to 70°C, V_{DD} = 3.3V ± 0.3V)

SYMBOL	PARAMETER	TEST CONDITION	MIN	TYP	MAX	UNIT	
I _{IL}	Input Leakage Current (Except NU pin)	V _{IN} = 0 to V _{DD}	-1	-	1	μA	
I _{LO}	Output Leakage Current	$\overline{CE} = V_{IH}$ or $\overline{WE} = V_{IL}$ or $\overline{OE} = V_{IH}$ V _{OUT} = 0 to V _{DD}	-1	-	1	μA	
I _{I(NU)}	Input Current (NU pin)	V _{IN} = 0 to 0.8V	-1	-	20	μA	
		V _{IN} = 0 to 0.2V	-1	-	1		
V _{OH}	Output High Voltage	I _{OH} = -2mA	2.4	-	-	V	
		I _{OH} = -100μA	V _{DD} - 0.2	-	-		
V _{OL}	Output Low Voltage	I _{OL} = 2mA	-	-	0.4		
		I _{OL} = 100μA	-	-	0.2		
I _{DDO}	Operating Current	$\overline{CE} = V_{IL}$, I _{out} = 0mA Other Inputs = V _{IH} / V _{IL}	tcycle = 10ns	-	-	230	mA
			tcycle = 12ns	-	-	190	
			tcycle = 15ns	-	-	170	
			tcycle = 20ns	-	-	150	
I _{DDS1}	Standby Current	$\overline{CE} = V_{IH}$, Other Inputs = V _{IH} / V _{IL}	-	-	20	mA	
I _{DDS2}		$\overline{CE} = V_{DD} - 0.2V$ Other Inputs = V _{DD} - 0.2V or 0.2V	-	-	2		

CAPACITANCE (Ta = 25°C, f = 1.0MHz)

SYMBOL	PARAMETER	TEST CONDITION	MAX	UNIT
C _{IN}	Input Capacitance	V _{IN} = GND	6	pF
C _{I/O}	Input/Output Capacitance	V _{I/O} = GND	8	pF

NOTE : This parameter is periodically sampled and is not 100% tested.

OPERATING MODE

MODE	\overline{CE}	\overline{OE}	\overline{WE}	\overline{LB}	\overline{UB}	I/O1 to I/O8	I/O9 to I/O16	POWER
Read	L	L	H	L	L	Output	Output	I _{DDO}
				H	L	High Impedance	Output	I _{DDO}
				L	H	Output	High Impedance	I _{DDO}
Write	L	X	L	L	L	Input	Input	I _{DDO}
				H	L	High Impedance	Input	I _{DDO}
				L	H	Input	High Impedance	I _{DDO}
Outputs Disable	L	H	H	X	X	High Impedance	High Impedance	I _{DDO}
	L	X	X	H	H			
Standby	H	X	X	X	X	High Impedance	High Impedance	I _{DDs}

X : H or L

NOTE : N.U. pin must be kept open electrically or pulled down to GND level or less than 0.8V.
Applying a voltage more than 0.8V to N.U. pin is prohibited.

AC CHARACTERISTICS (Ta = 0° to 70°C⁽¹⁾, V_{DD} = 3.3V ± 0.3V)

READ CYCLE

SYMBOL	PARAMETER	TC55V1664BJ/BFT-10		TC55V1664BJ/BFT-12		TC55V1664BJ/BFT-15		UNIT
		MIN	MAX	MIN	MAX	MIN	MAX	
t _{RC}	Read Cycle Time	10	–	12	–	15	–	ns
t _{ACC}	Address Access Time	–	10	–	12	–	15	
t _{CO}	\overline{CE} Access Time	–	10	–	12	–	15	
t _{OE}	\overline{OE} Access Time	–	5	–	6	–	8	
t _{BA}	$\overline{UB}, \overline{LB}$ Access Time	–	5	–	6	–	8	
t _{OH}	Output Data Hold Time from Address Change	3	–	3	–	3	–	
t _{COE}	Output Enable Time from \overline{CE}	3	–	3	–	3	–	
t _{OEE}	Output Enable Time from \overline{OE}	1	–	1	–	1	–	
t _{BE}	Output Enable Time from $\overline{UB}, \overline{LB}$	1	–	1	–	1	–	
t _{COD}	Output Disable Time from \overline{CE}	–	6	–	7	–	8	
t _{ODO}	Output Disable Time from \overline{OE}	–	6	–	7	–	8	
t _{BD}	Output Disable Time from $\overline{UB}, \overline{LB}$	–	6	–	7	–	8	

WRITE CYCLE

SYMBOL	PARAMETER	TC55V1664BJ/BFT-10		TC55V1664BJ/BFT-12		TC55V1664BJ/BFT-15		UNIT
		MIN	MAX	MIN	MAX	MIN	MAX	
t _{WC}	Write Cycle Time	10	–	12	–	15	–	ns
t _{WP}	Write Pulse Width	7	–	8	–	9	–	
t _{CW}	Chip Enable to End of Write	8	–	8	–	12	–	
t _{BW}	$\overline{UB}, \overline{LB}$ Enable to End of Write	8	–	8	–	11	–	
t _{AW}	Address Valid to End of Write	8	–	8	–	11	–	
t _{AS}	Address Set Up Time	0	–	0	–	0	–	
t _{WR}	Write Recovery Time	0	–	0	–	0	–	
t _{DS}	Data Set Up Time	6	–	7	–	8	–	
t _{DH}	Data Hold Time	0	–	0	–	0	–	
t _{OEW}	Output Enable Time from \overline{WE}	1	–	1	–	1	–	
t _{ODW}	Output Disable Time from \overline{WE}	–	6	–	7	–	8	

AC TEST CONDITIONS

Input Pulse Level	3.0V/0.0V
Input Pulse Rise and Fall Time	2ns
Input Timing Measurement Reference Level	1.5V
Output Timing Measurement Reference Level	1.5V
Output Load	Fig. 1

Fig. 1

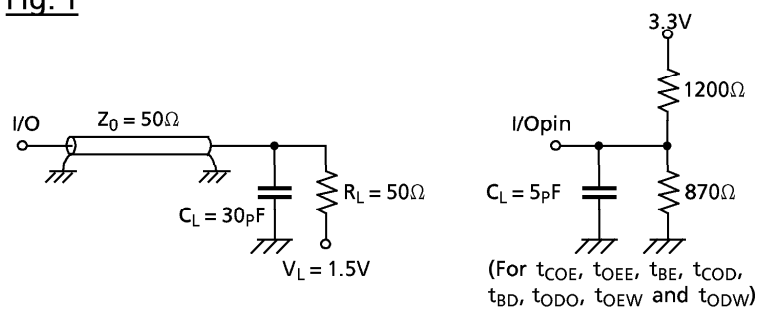

TIMING WAVEFORMS
READ CYCLE (2)

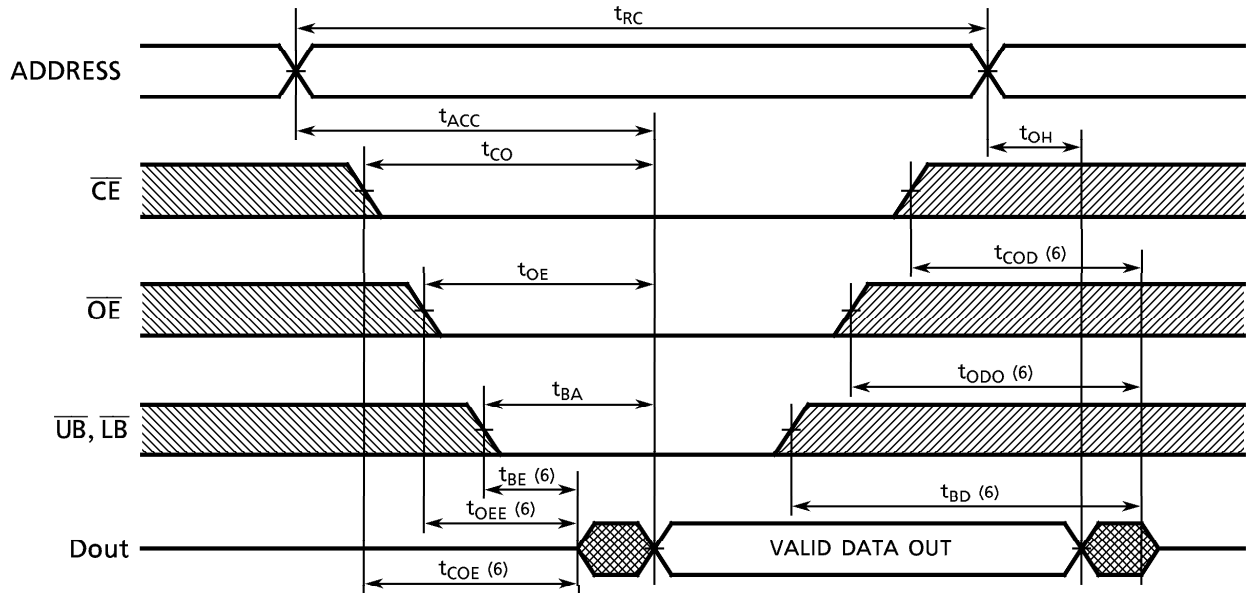

WRITE CYCLE 1 (5) (\overline{WE} Controlled)

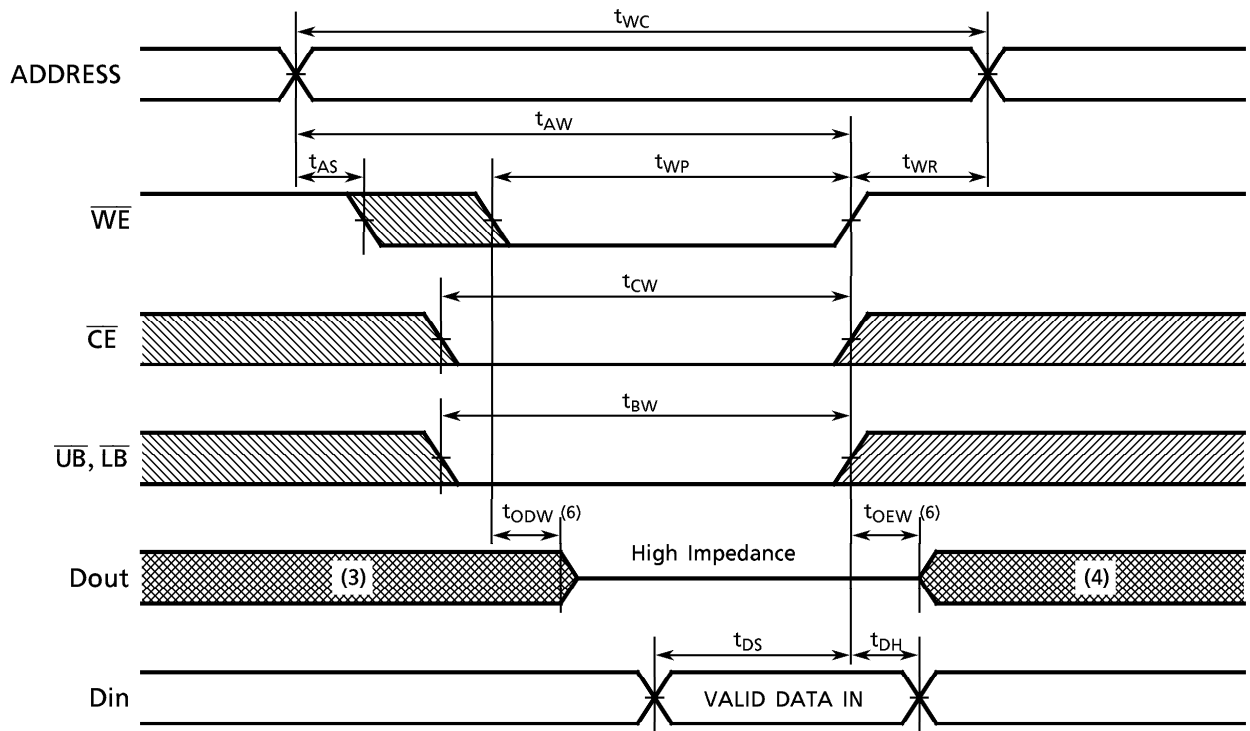

WRITE CYCLE 2 (5) (\overline{CE} Controlled)

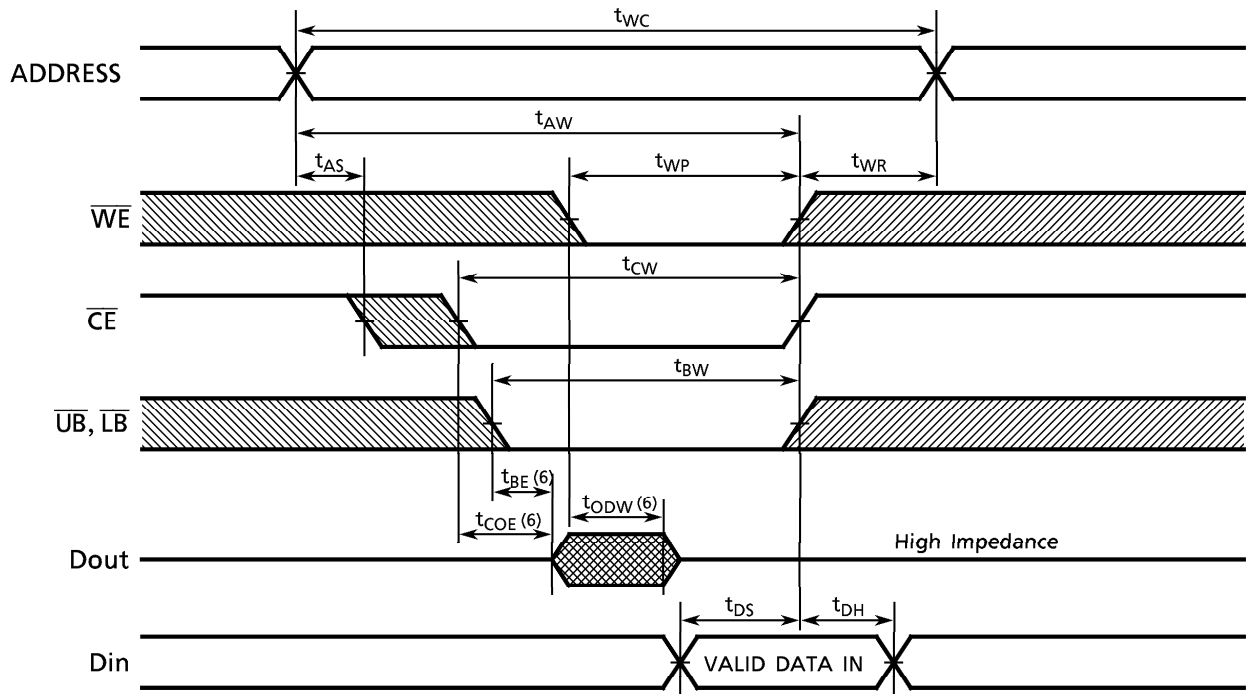

WRITE CYCLE 3 (5) ($\overline{UB}, \overline{LB}$ Controlled)

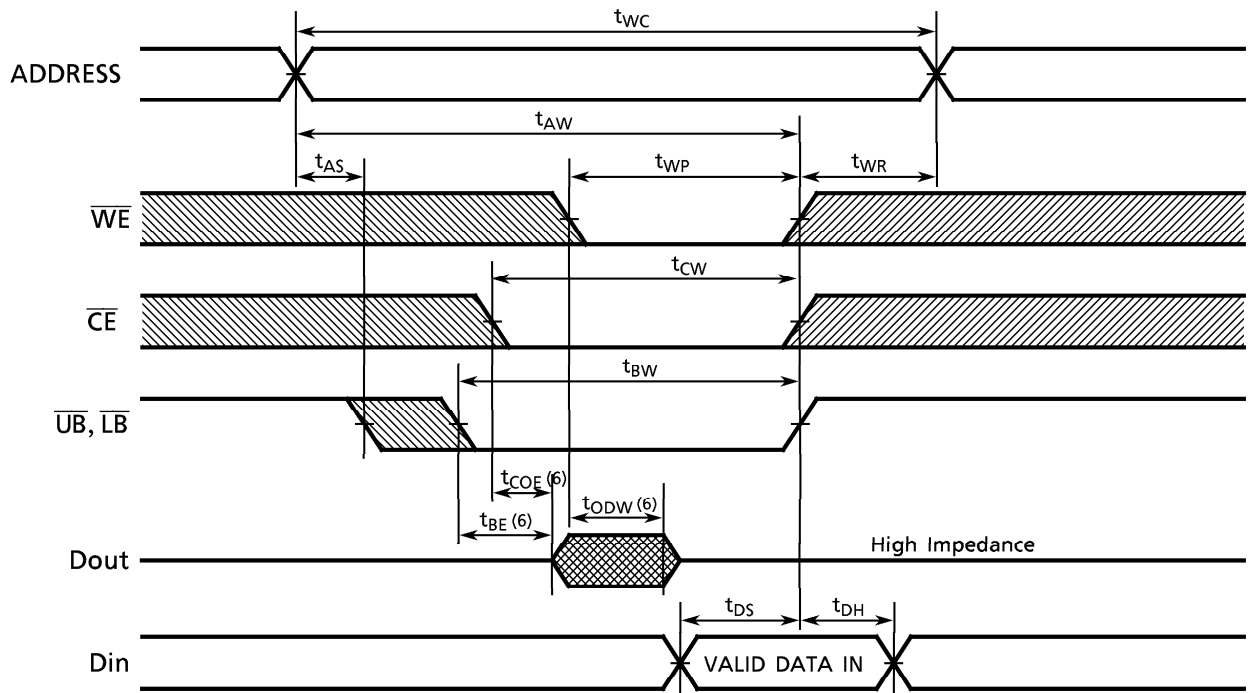

NOTE :

1. The operating temperature (Ta) is guaranteed with transverse air flow exceeding 400 linear feet per minute.
2. \overline{WE} is High for Read Cycle.
3. Assuming that \overline{CE} Low transition occurs coincident with or after \overline{WE} Low transition, Outputs remain in a high impedance state.
4. Assuming that \overline{CE} High transition occurs coincident with or prior \overline{WE} High transition, Outputs remain in a high impedance state.
5. Assuming that \overline{OE} is High for Write Cycle, Outputs are in a high impedance state during this period.
6. These parameters are specified as follows and measured by using the load shown in Fig. 1.

(A) $t_{COE}, t_{OEE}, t_{BE}, t_{OEW}$ ····· Output Enable Time

(B) $t_{COD}, t_{ODO}, t_{BD}, t_{ODW}$ ····· Output Disable Time

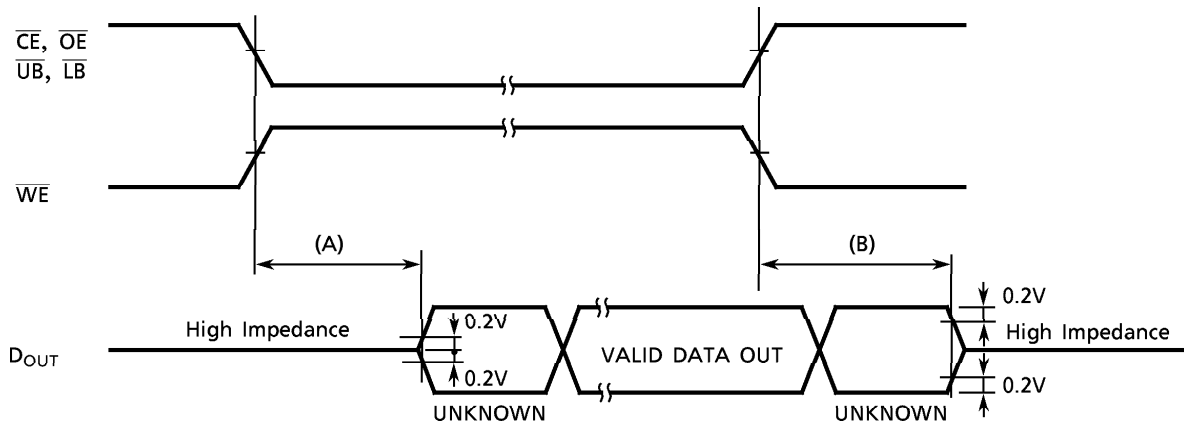

PACKAGE DIMENSIONS

Plastic SOJ (SOJ44-P-400-1.27)

Unit in mm

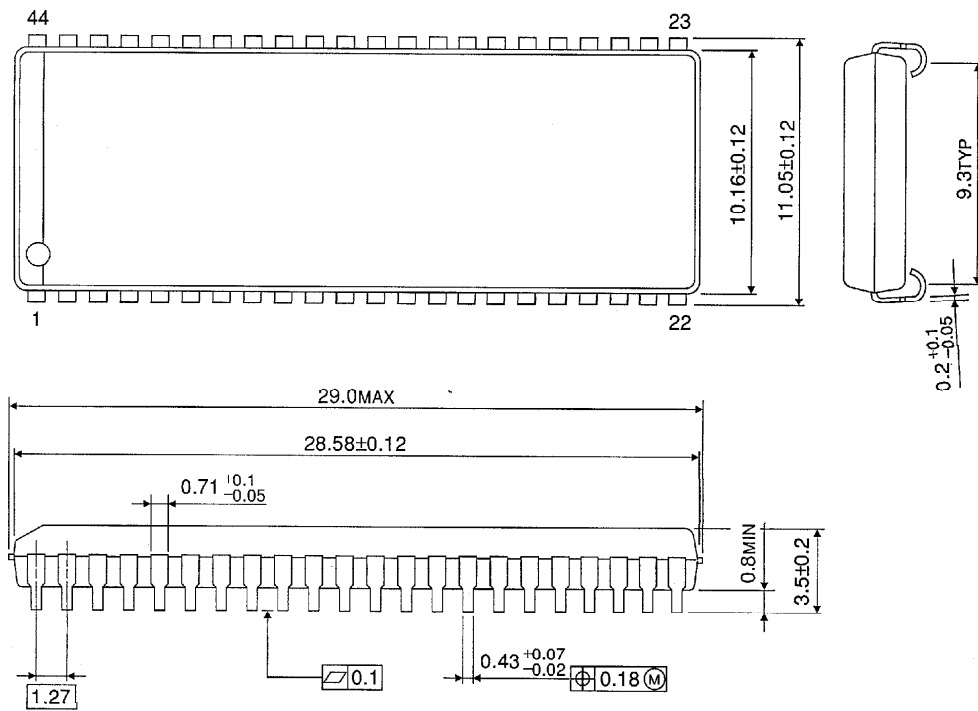

Weight : 1.64g (Typ)

PACKAGE DIMENSIONS

Plastic TSOP (TSOPII 44-P-400-0.80)

Unit in mm

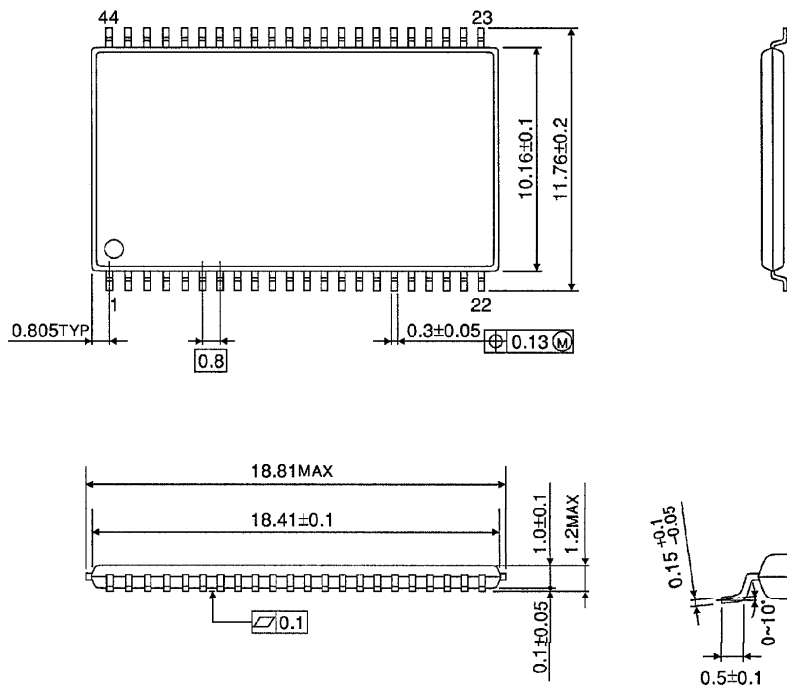

Weight : 0.45g (Typ)