

32,768-WORD BY 8-BIT CMOS STATIC RAM

DESCRIPTION

The TC55V328BJ/BFT is a 262,144-bit high-speed static random access memory (SRAM) organized as 32,768 words by 8 bits. Fabricated using CMOS technology and advanced circuit techniques to provide high speed and low-voltage operation, it operates from a single 3.3 V power supply. There are two control inputs. Chip enable (CE) can be used to place the device in a low-power mode, and output enable (OE) provides fast memory access. This device is well suited to cache memory applications where high-speed access and high-speed storage are required. All inputs and outputs are directly LVTTL compatible. The TC55V328BJ/BFT is available in plastic 28-pin SOJ (300 mil width) and TSOP packages for high density surface assembly.

FEATURES

- Fast access time (the following are maximum values)
 - TC55V328BJ/BFT-12: 12 ns
 - TC55V328BJ/BFT-15: 15 ns
- Low-power dissipation (the following are maximum values)
 - Operating: 120 mA (12 ns type)
 - Operating: 100 mA (15 ns type)
 - Standby : 300 μ A (all devices)
- Single power supply voltage:
 - TC55V328BJ/BFT-12 : 3.3V +0.3V or -0.2V
 - TC55V328BJ/BFT-15 : 3.3V \pm 0.3V
- Fully static operation
- All inputs and outputs are LVTTL compatible
- Output buffer control using OE
- Packages:
 - SOJ28-P-300-1.27A (BJ) (Weight: 0.83 g typ)
 - TSOP I 28-P-0.55 (BFT) (Weight: 0.22 g typ)

PIN ASSIGNMENT

A0 to A14	Address Inputs
I/O1 to I/O8	Data Inputs / Outputs
\overline{CE}	Chip Enable Input
\overline{WE}	Write Enable Input
\overline{OE}	Output Enable Input
V _{DD}	Power (+ 3.3V)
GND	Ground

PIN CONNECTION

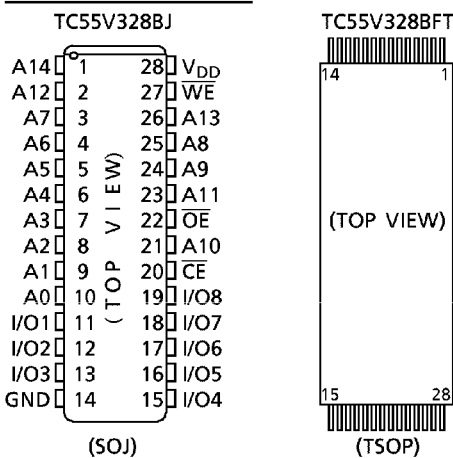

BLOCK DIAGRAM

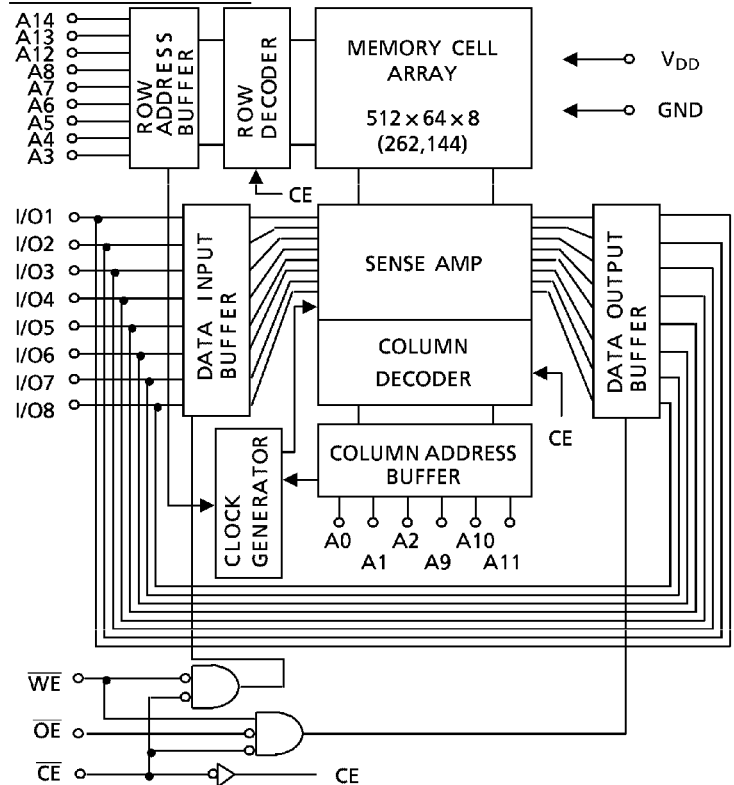

Pin No.	1	2	3	4	5	6	7	8	9	10	11	12	13	14
Pin Name	OE	A ₁₁	A ₉	A ₈	A ₁₃	WE	V _{DD}	A ₁₄	A ₁₂	A ₇	A ₆	A ₅	A ₄	A ₃
Pin No.	15	16	17	18	19	20	21	22	23	24	25	26	27	28
Pin Name	A ₂	A ₁	A ₀	I/O1	I/O2	I/O3	GND	I/O4	I/O5	I/O6	I/O7	I/O8	\overline{CE}	A ₁₀

961001EBA1

● TOSHIBA is continually working to improve the quality and the reliability of its products. Nevertheless, semiconductor devices in general can malfunction or fail due to their inherent electrical sensitivity and vulnerability to physical stress. It is the responsibility of the buyer, when utilizing TOSHIBA products, to observe standards of safety, and to avoid situations in which a malfunction or failure of a TOSHIBA product could cause loss of human life, bodily injury or damage to property. In developing your designs, please ensure that TOSHIBA products are used within specified operating ranges as set forth in the most recent products specifications. Also, please keep in mind the precautions and conditions set forth in the TOSHIBA Semiconductor Reliability Handbook.

● The products described in this document are subject to foreign exchange and foreign trade control laws.

● The information contained herein is presented only as a guide for the applications of our products. No responsibility is assumed by TOSHIBA CORPORATION for any infringements of intellectual property or other rights of the third parties which may result from its use. No license is granted by implication or otherwise under any intellectual property or other rights of TOSHIBA CORPORATION or others.

● The information contained herein is subject to change without notice.

MAXIMUM RATINGS

SYMBOL	RATING	VALUE	UNIT
V _{DD}	Power Supply Voltage	- 0.5 to 4.6	V
V _{IN}	Input Voltage	- 0.5* to 4.6	V
V _{I/O}	Input/Output Voltage	- 0.5* to V _{DD} + 0.5**	V
P _D	Power Dissipation	0.5	W
T _{solder}	Soldering Temperature (10 s)	260	°C
T _{strg}	Storage Temperature	- 65 to 150	°C
T _{opr}	Operating Temperature	- 10 to 85	°C

*: - 1.5V with a pulse width of 20% of t_{RC} (4ns max.)

**: V_{DD} + 1.5V with a pulse width of 20% of t_{RC} (4ns max.)

DC RECOMMENDED OPERATING CONDITIONS (Ta = 0° to 70°C)

SYMBOL	PARAMETER	MIN	TYP	MAX	UNIT
V _{DD}	Power Supply Voltage	-12	3.1	3.3	V
		-15	3.0	3.3	
V _{IH}	Input High Voltage	2.0	-	V _{DD} + 0.3**	V
V _{IL}	Input Low Voltage	-0.3*	-	0.8	V

* : - 1.0V with a pulse width of 20% of t_{RC} (4ns max.)

** : V_{DD} + 1.0V with a pulse width of 20% of t_{RC} (4ns max.)

DC CHARACTERISTICS (Ta = 0° to 70°C, -12:V_{DD} = 3.3V + 0.3V or -0.2V, -15:V_{DD} = 3.3V ± 0.3V)

SYMBOL	PARAMETER	TEST CONDITION	MIN	TYP	MAX	UNIT	
I _{IL}	Input Leakage Current	V _{IN} = 0 V to V _{DD}	-	-	± 1	μA	
I _{LO}	Output Leakage Current	$\overline{CE} = V_{IH}$ or $\overline{OE} = V_{IH}$ or $\overline{WE} = V_{IL}$ V _{OUT} = 0 V to V _{DD}	-	-	± 1	μA	
V _{OH}	Output High Voltage	I _{OH} = - 2 mA	2.4	-	-	V	
		I _{OH} = - 100 μA	V _{DD} - 0.2	-	-		
V _{OL}	Output Low Voltage	I _{OL} = 2 mA	-	-	0.4	V	
		I _{OL} = 100 μA	-	-	0.2		
I _{DDO}	Operating Current	t _{cycle} = Minimum Cycle, $\overline{CE} = V_{IL}$ Other Inputs = V _{IH} or V _{IL} , I _{out} = 0 mA	- 12	-	-	120	mA
			- 15	-	-	100	
I _{DDS1}	Standby Current	$\overline{CE} = V_{IH}$ Other Inputs = V _{IH} or V _{IL} , t _{cycle} = Minimum Cycle	-	-	20	mA	
I _{DDS2}		$\overline{CE} = V_{DD} - 0.2 V$ Other Inputs = V _{DD} - 0.2 V or 0.2 V	-	-	300	μA	

CAPACITANCE (Ta = 25°C, f = 1.0 MHz)

SYMBOL	PARAMETER	TEST CONDITION	MAX	UNIT
C _{IN}	Input Capacitance	V _{IN} = GND	6	pF
C _{I/O}	Input/Output Capacitance	V _{I/O} = GND	10	pF

Note: This parameter is periodically sampled and is not 100% tested.

OPERATING MODE

MODE	\overline{CE}	\overline{OE}	\overline{WE}	I/O1 to I/O8	POWER
Read	L	L	H	Output	I _{DDO}
Write	L	x	L	Input	I _{DDO}
Outputs Disable	L	H	H	High Impedance	I _{DDO}
Standby	H	x	x	High Impedance	I _{DDS}

x: Don't care

AC CHARACTERISTICS (Ta = 0° to 70°C, -12: V_{DD} = 3.3V + 0.3V or -0.2V, -15: V_{DD} = 3.3V ± 0.3V)

READ CYCLE

SYMBOL	PARAMETER	TC55 V328BJ/BFT-12		TC55 V328BJ/BFT-15		UNIT
		MIN	MAX	MIN	MAX	
t _{RC}	Read Cycle Time	12	-	15	-	ns
t _{ACC}	Address Access Time	-	12	-	15	
t _{CO}	Chip Enable Access Time	-	12	-	15	
t _{OE}	Output Enable Access Time	-	6	-	7	
t _{OH}	Output Data Hold Time from Address Change	3	-	3	-	
t _{COE}	Output Enable Time from Chip Enable	3	-	3	-	
t _{COD}	Output Disable Time from Chip Enable	-	7	-	8	
t _{OEE}	Output Enable Time from Output Enable	1	-	1	-	
t _{ODO}	Output Disable Time from Output Enable	-	7	-	8	

WRITE CYCLE

SYMBOL	PARAMETER	TC55 V328BJ/BFT-12		TC55 V328BJ/BFT-15		UNIT
		MIN	MAX	MIN	MAX	
t _{WC}	Write Cycle Time	12	-	15	-	ns
t _{WP}	Write Pulse Width	8	-	10	-	
t _{AW}	Address Valid to End of Write	10	-	10	-	
t _{CW}	Chip Enable to End of Write	10	-	11	-	
t _{AS}	Address Setup Time	0	-	0	-	
t _{WR}	Write Recovery Time	0	-	0	-	
t _{DS}	Data Setup Time	7	-	8	-	
t _{DH}	Data Hold Time	0	-	0	-	
t _{OEW}	Output Enable Time from \overline{WE}	1	-	1	-	
t _{ODW}	Output Disable Time from \overline{WE}	-	7	-	8	

AC TEST CONDITIONS

Input Pulse Levels	3.0 V, 0.0 V
Input Pulse Rise and Fall Time	3 ns
Input Timing Measurement Reference Levels	1.5 V
Output Timing Measurement Reference Levels	1.5 V
Output Load	Fig. 1

FIG. 1

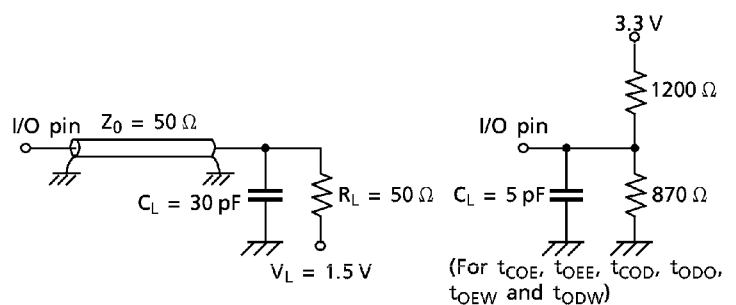

TIMING DIAGRAMS

READ CYCLE (See Note 1)

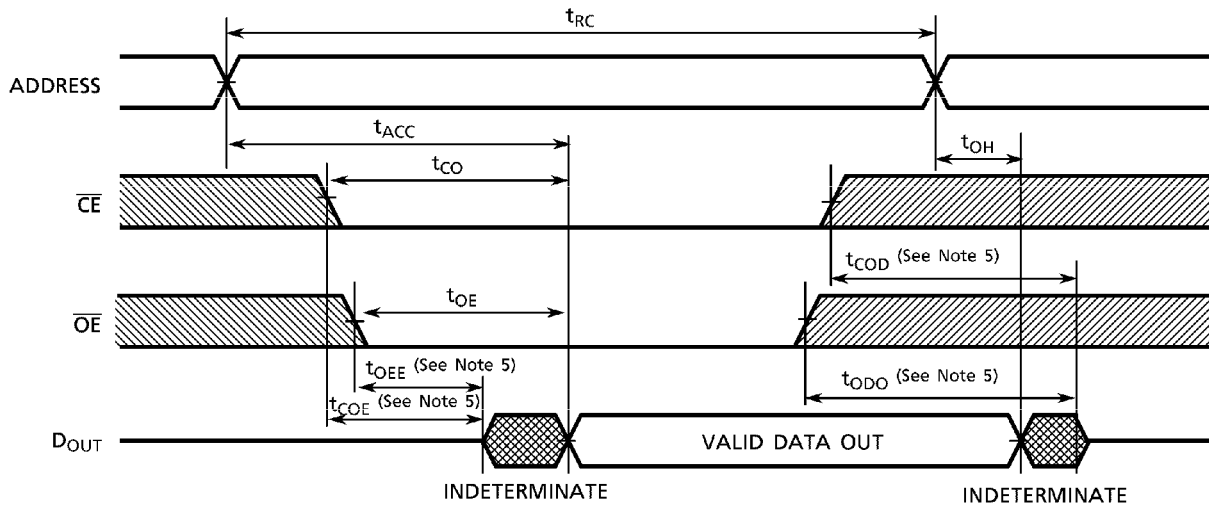

WRITE CYCLE (\overline{WE} CONTROLLED 1) (See Note 4)

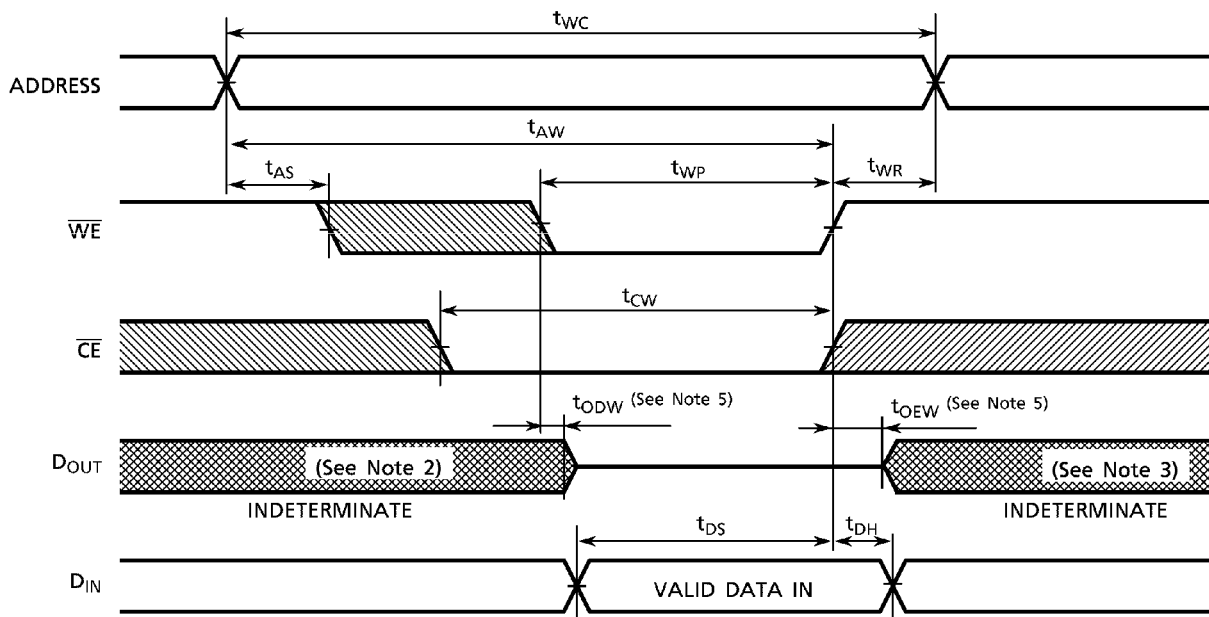

WRITE CYCLE 2 (CE CONTROLLED) (See Note 4)

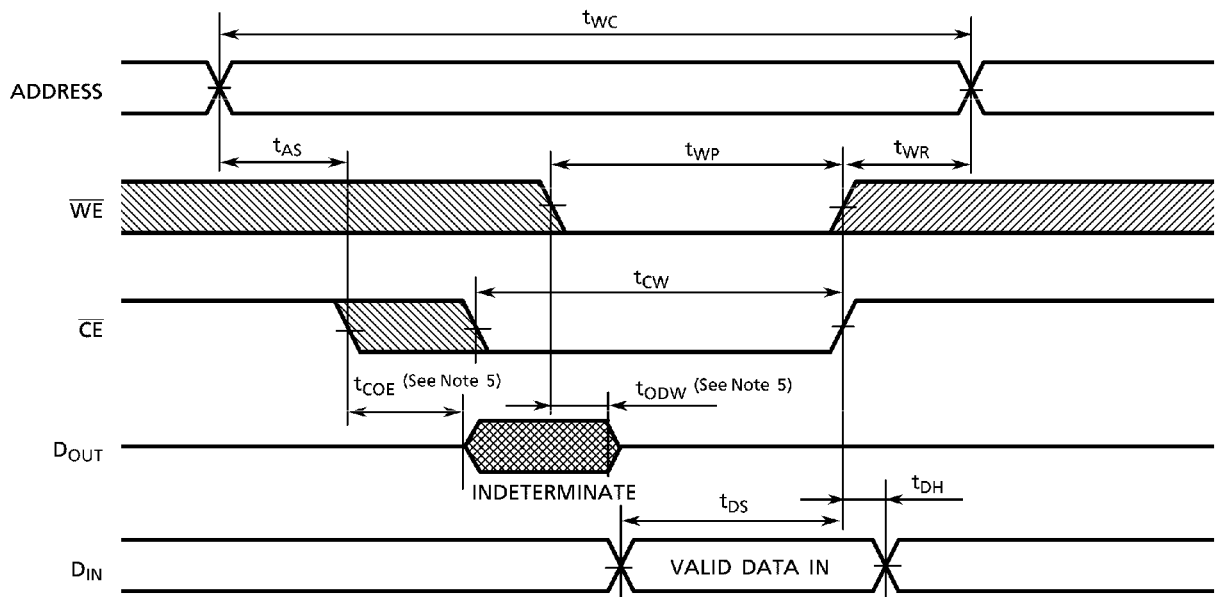

Note: (1) \overline{WE} remains HIGH for the read cycle.

(2) If \overline{CE} goes LOW coincident with or after \overline{WE} goes LOW, the outputs will remain at high impedance.

(3) If \overline{CE} goes HIGH coincident with or before \overline{WE} goes HIGH, the outputs will remain at high impedance.

(4) If \overline{OE} is HIGH during the write cycle, the outputs will remain at high impedance.

(5) The parameters are specified below measured using the load shown in Fig. 1.

(A) t_{COE} , t_{OEE} , t_{OEW} ····· Output Enable Time

(B) t_{COD} , t_{ODO} , t_{ODW} ····· Output Disable Time

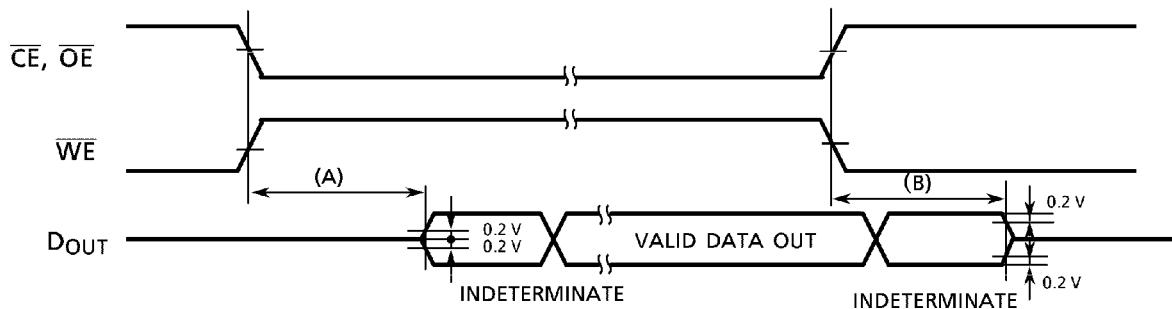

OUTLINE DRAWINGS

Plastic SOJ (SOJ28-P-300-1.27A)

Unit in mm

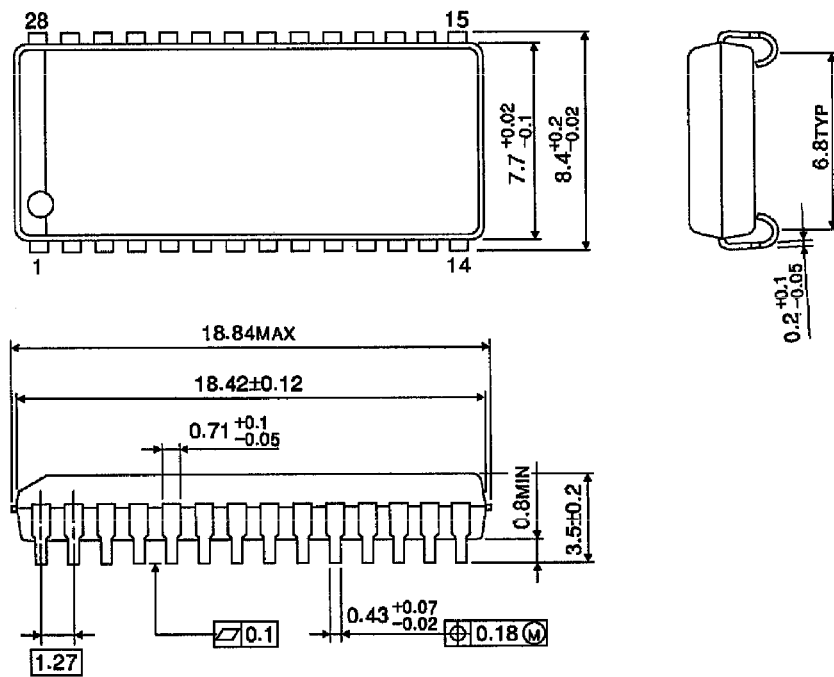

Weight : 0.83g (Typ.)

OUTLINE DRAWINGS

Plastic TSOP (TSOP I 28-P-0.55)

Unit in mm

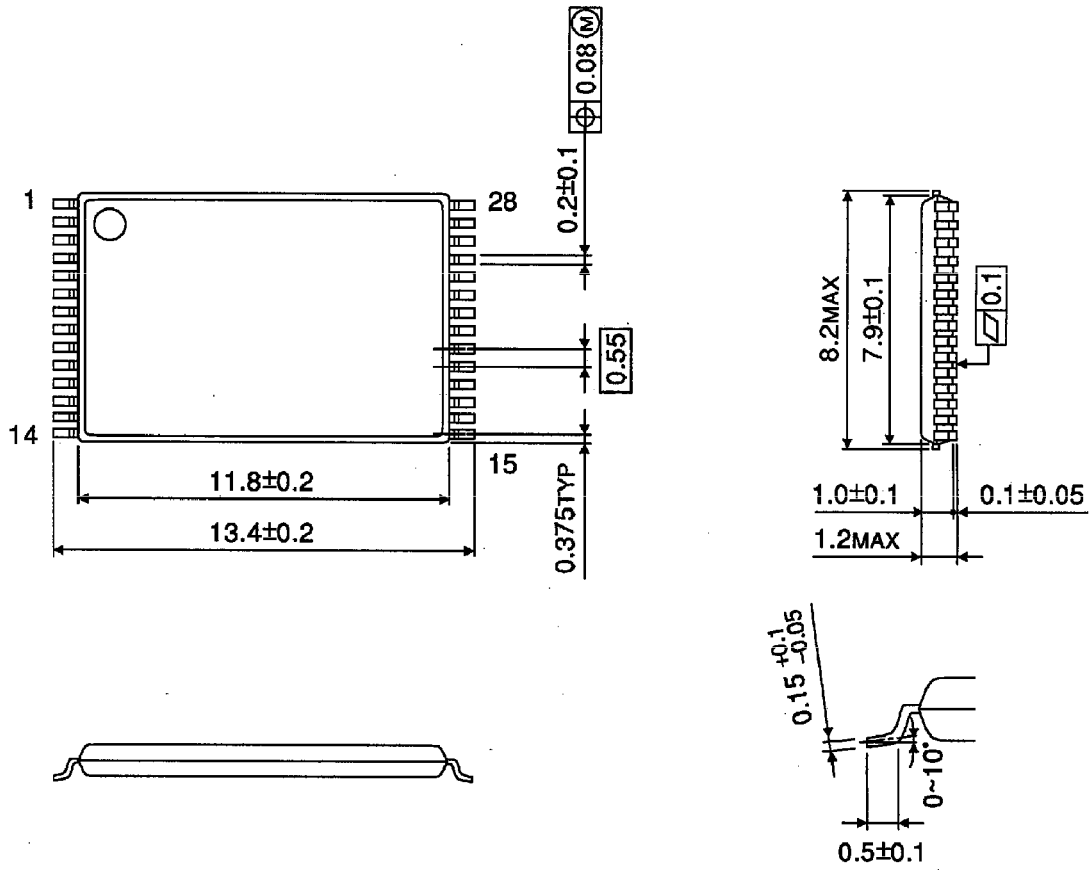

Weight : 0.22g (Typ.)