

131,072 WORD × 8 BIT CMOS UV ERASABLE AND ELECTRICALLY PROGRAMMABLE READ ONLY MEMORY

DESCRIPTION

The TC57H1000AD/TC57H1001AD is a 131,072 word × 8 bit CMOS ultraviolet light erasable and electrically programmable read only memory.

The TC57H1000AD is JEDEC standard pin configuration and the TC57H1001AD is compatible with 28 pin 1M bit Mask ROM. Both products are packed in 32 pin standard cerdip package.

The TC57H1000AD/TC57H1001AD is fabricated with the CMOS technology. Advanced circuit techniques provide both high speed and low power features with a maximum operating current of 40mA/11.8MHz and access time of 85ns/100ns.

The programming times of the TC57H1000AD / TC57H1001AD except overhead times of EPROM programmer is only 14 seconds by using the high speed programming algorithm.

FEATURES

- Peripheral circuit : CMOS
- Memory cell : N-MOS
- Access time

	- 85	- 100
t _{ACC}	85ns	100ns
V _{CC}	5V ± 10%	
- Low power dissipation
 - Active : 40mA/11.8MHz
 - Standby: 100µA (T_a = 70°C)
- Wide operating temperature range : 0~70°C
- Single 5V power supply
- Full static operation
- High speed programming operation : t_{pw} 0.1ms
- Input and output TTL compatible
- JEDEC standard 32 pin : TC57H1000AD
- 1M MROM compatible : TC57H1001AD
- Standard 32 pin DIP cerdip package

PIN CONNECTION (TOP VIEW)

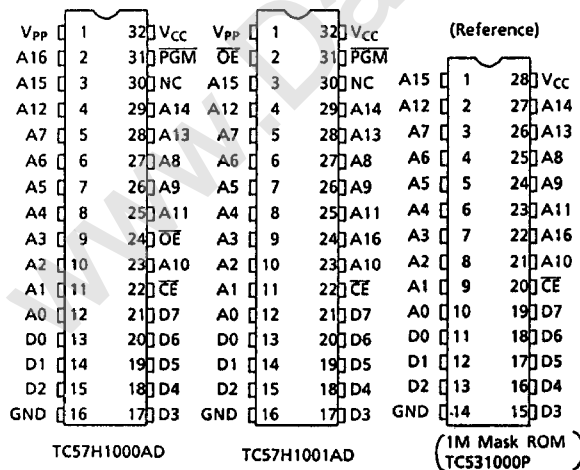

PIN NAMES

A0~A16	Address Inputs
D0~D7	Outputs (Inputs)
CE	Chip Enable Input
OE	Output Enable Input
PGM	Program Control Input
V _{CC}	V _{CC} Supply Voltage
V _{PP}	Program Supply Voltage
GND	Ground
NC	No Connection

TC57H1000AD-85, TC57H1000AD-100 TC57H1001AD-85, TC57H1001AD-100

BLOCK DIAGRAM

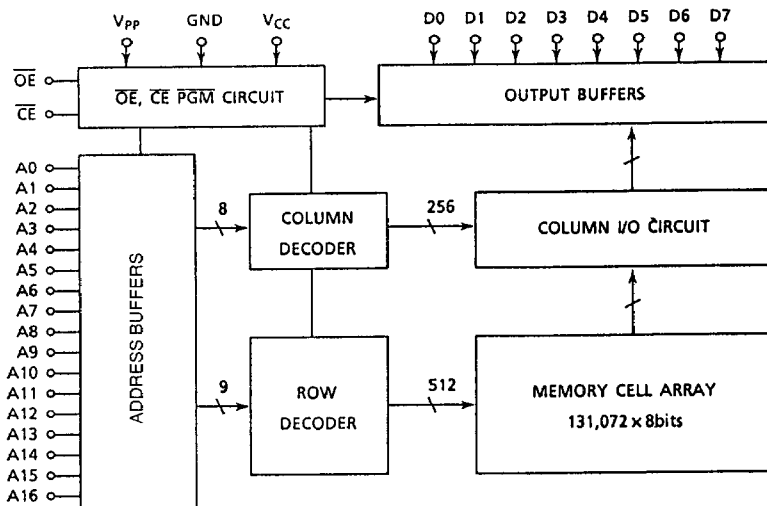

MODE SELECTION

MODE \ PIN	PGM	\overline{CE}	\overline{OE}	V_{PP}	V_{CC}	D0~D7	Power
Read	H	L	L	5V	5V	Data Out	Active
Output Deselect	*	*	H			High Impedance	
Standby	*	H	*			High Impedance	Standby
Program	L	L	H	12.75V	6.25V	Data In	Active
Program Inhibit	*	H	*			High Impedance	
	H	L	H			High Impedance	
Program Verify	H	L	L			Data Out	

* : H or L

MAXIMUM RATINGS

SYMBOL	ITEM	RATING	UNIT
V_{CC}	V_{CC} Power Supply Voltage	-0.6~7.0	V
V_{PP}	Program Supply Voltage	-0.6~14.0	V
V_{IN}	Input Voltage	-0.6~7.0	V
$V_{I/O}$	Input/Output Voltage	-0.6~ $V_{CC} + 0.5$	V
P_D	Power Dissipation	1.5	W
T_{SOLDER}	Soldering Temperature Time	260·10	°C·sec
T_{STRG}	Storage Temperature	-65~125	°C
T_{OPR}	Operating Temperature	0~70	°C

TC57H1000AD-85, TC57H1000AD-100 TC57H1001AD-85, TC57H1001AD-100

READ OPERATION

DC RECOMMENDED OPERATING CONDITIONS

SYMBOL	PARAMETER	TC57H1000AD / 1001AD - 85 / - 100		UNIT
		MIN.	MAX.	
V_{IH}	Input High Voltage	2.2	$V_{CC} + 0.3$	V
V_{IL}	Input Low Voltage	-0.3	0.8	V
V_{CC}	V_{CC} Power Supply Voltage	4.50	5.50	V
V_{PP}	V_{PP} Power Supply Voltage	$V_{CC} - 0.6$	$V_{CC} + 0.6$	V

DC AND OPERATING CHARACTERISTICS ($T_a = 0 \sim 70^\circ\text{C}$)

SYMBOL	PARAMETER	TEST CONDITION	MIN.	TYP.	MAX.	UNIT
I_{LI}	Input Current	$V_{IN} = 0 \sim V_{CC}$	-	-	± 10	μA
I_{CCO1}	Operating Current	$\overline{CE} = 0\text{V}$ $I_{OUT} = 0\text{mA}$	-	-	40	mA
I_{CCO2}						
I_{CCS1}	Standby Current	$\overline{CE} = V_{IH}$	-	-	1	mA
I_{CCS2}		$\overline{CE} = V_{CC} - 0.2\text{V}$	-	-	100	μA
V_{OH}	Output High Voltage	$I_{OH} = -400\mu\text{A}$	2.4	-	-	V
V_{OL}	Output Low Voltage	$I_{OL} = 2.1\text{mA}$	-	-	0.4	V
I_{PP1}	V_{PP} Current	$V_{PP} = V_{CC} \pm 0.6\text{V}$	-	-	± 10	μA
I_{LO}	Output Leakage Current	$V_{OUT} = 0.4\text{V} \sim V_{CC}$	-	-	10	μA

AC CHARACTERISTICS ($T_a = 0 \sim 70^\circ\text{C}$, $V_{PP} = V_{CC} \pm 0.6\text{V}$)

SYMBOL	PARAMETER	TC57H1000AD / 1001AD - 85		TC57H1000AD / 1001AD - 100		UNIT
		MIN.	MAX.	MIN.	MAX.	
t_{ACC}	Address Access Time	-	85	-	100	ns
t_{CE}	\overline{CE} to Output Valid	-	85	-	100	ns
t_{OE}	\overline{OE} to Output Valid	-	45	-	50	ns
t_{PGM}	\overline{PGM} to Output Valid	-	45	-	50	ns
t_{DF1}	\overline{CE} to Output in High-Z	0	30	0	40	ns
t_{DF2}	\overline{OE} to Output in High-Z	0	30	0	40	ns
t_{DF3}	\overline{PGM} to Output in High-Z	0	30	0	40	ns
t_{OH}	Output Data Hold Time	0	-	0	-	ns

AC TEST CONDITIONS

- Output Load : 1 TTL Gate and $C_L = 100\text{pF}$
- Input Pulse Rise and Fall Times : 10ns Max.
- Input Pulse Levels : 0.45V~2.4V
- Timing Measurement Reference Level : Inputs 0.8V and 2.2V, Outputs 0.8V and 2.0V

TC57H1000AD-85, TC57H1000AD-100 TC57H1001AD-85, TC57H1001AD-100

CAPACITANCE* ($T_a = 25^\circ\text{C}$, $f = 1\text{MHz}$)

SYMBOL	PARAMETER	TEST CONDITION	MIN.	TYP.	MAX.	UNIT
C_{IN}	Input Capacitance	$V_{IN} = 0V$	-	4	9	P_F
C_{OUT}	Output Capacitance	$V_{OUT} = 0V$	-	10	12	

*This parameter is periodically sampled and is not 100% tested.

TIMING WAVEFORMS (READ)

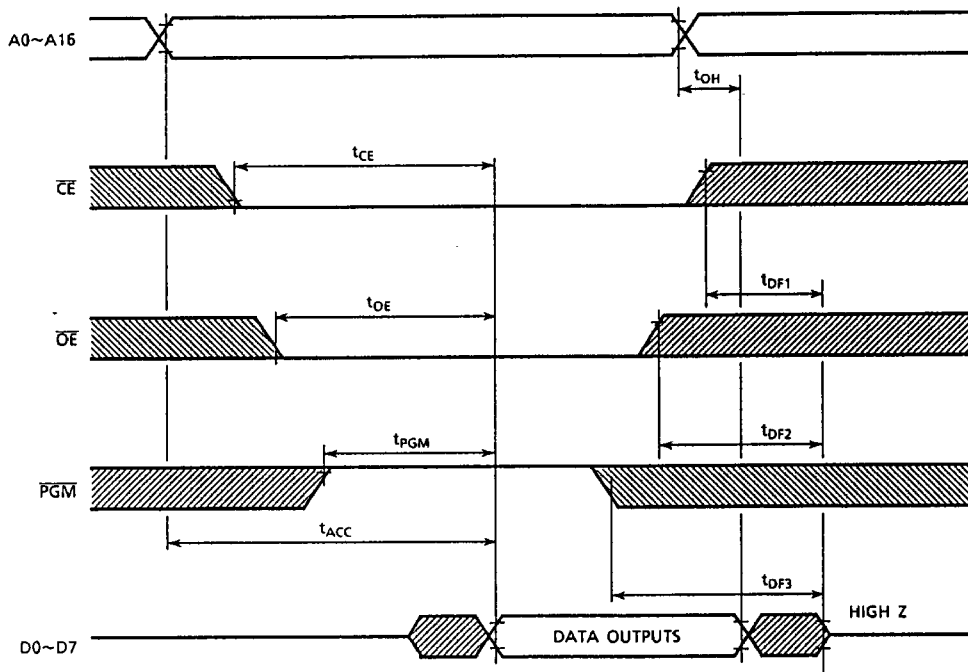

TC57H1000AD-85, TC57H1000AD-100 TC57H1001AD-85, TC57H1001AD-100

HIGH SPEED PROGRAM OPERATION

DC RECOMMENDED OPERATING CONDITIONS

SYMBOL	PARAMETER	MIN.	TYP.	MAX.	UNIT
V_{IH}	Input High Voltage	2.2	-	$V_{CC} + 1.0$	V
V_{IL}	Input Low Voltage	-0.3	-	0.8	V
V_{CC}	V_{CC} Power Supply Voltage	6.00	6.25	6.50	V
V_{PP}	V_{PP} Power Supply Voltage	12.50	12.75	13.00	V

DC AND OPERATING CHARACTERISTICS ($T_a = 25 \pm 5^\circ\text{C}$, $V_{CC} = 6.25\text{V} \pm 0.25\text{V}$, $V_{PP} = 12.75\text{V} \pm 0.25\text{V}$)

SYMBOL	PARAMETER	TEST CONDITION	MIN.	TYP.	MAX.	UNIT
I_{LI}	Input Current	$V_{IN} = 0 \sim V_{CC}$	-	-	± 10	μA
V_{OH}	Output High Voltage	$I_{OH} = -400\mu\text{A}$	2.4	-	-	V
V_{OL}	Output Low Voltage	$I_{OL} = 2.1\text{mA}$	-	-	0.4	V
I_{CC}	V_{CC} Supply Current	-	-	-	30	mA
I_{PP2}	V_{PP} Supply Current	$V_{PP} = 13.0\text{V}$	-	-	50	mA

AC PROGRAMMING CHARACTERISTICS ($T_a = 25 \pm 5^\circ\text{C}$, $V_{CC} = 6.25\text{V} \pm 0.25\text{V}$, $V_{PP} = 12.75\text{V} \pm 0.25\text{V}$)

SYMBOL	PARAMETER	TEST CONDITION	MIN.	TYP.	MAX.	UNIT
t_{AS}	Address Setup Time	-	2	-	-	μs
t_{AH}	Address Hold Time	-	2	-	-	μs
t_{CES}	$\overline{\text{CE}}$ Setup Time	-	2	-	-	μs
t_{CEH}	$\overline{\text{CE}}$ Hold Time	-	2	-	-	μs
t_{DS}	Data Set up Time	-	2	-	-	μs
t_{DH}	Data Hold Time	-	2	-	-	μs
t_{VS}	V_{PP} Set up Time	-	2	-	-	μs
t_{PW}	Program Pulse Width	-	0.095	0.1	0.105	ms
t_{OE}	$\overline{\text{OE}}$ to Output Valid	-	-	-	100	ns
t_{DF2}	$\overline{\text{OE}}$ to Output in High-Z	$\overline{\text{CE}} = V_{IL}$	-	-	90	ns

AC TEST CONDITIONS

- Output Load : 1 TTL Gate and C_L (100pF)
- Input Pulse Rise and Fall Time : 10ns Max.
- Input Pulse Levels : 0.45V~2.4V
- Timing Measurement Reference Level : Input 0.8V and 2.2V, Output 0.8V and 2.0V

TC57H1000AD-85, TC57H1000AD-100 TC57H1001AD-85, TC57H1001AD-100

TIMING WAVEFORMS (PROGRAM)

HIGH SPEED PROGRAM OPERATION

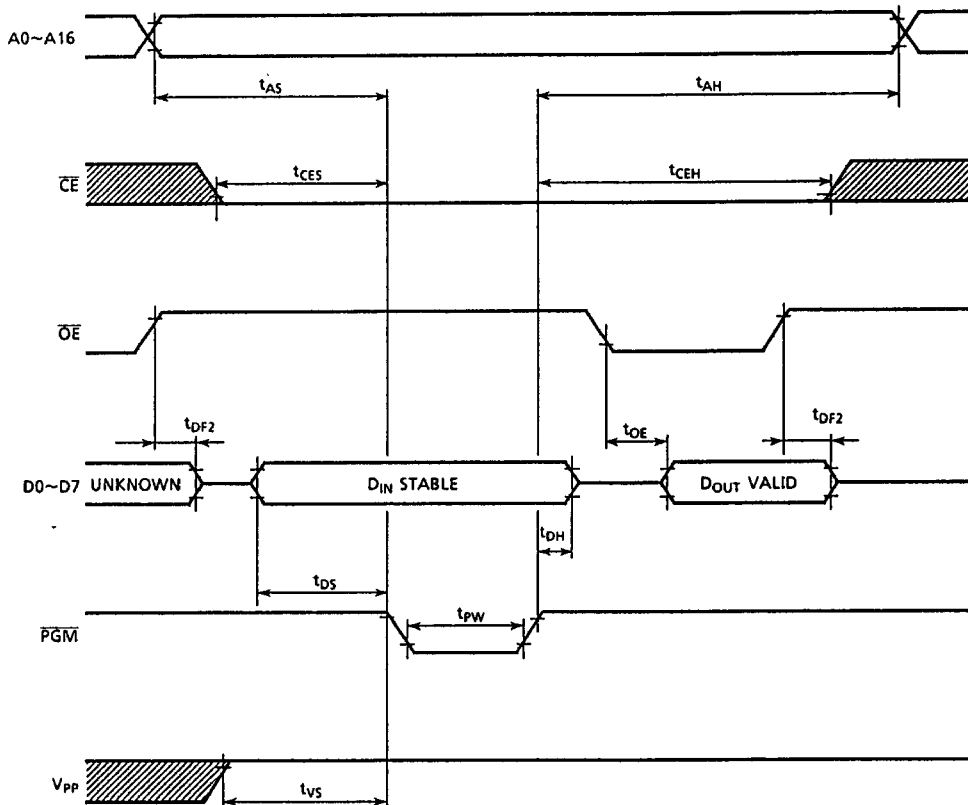

- Note 1. V_{CC} must be applied simultaneously or before V_{PP} and cut off simultaneously or after V_{PP} .
2. Removing the device from socket and setting the device in socket with $V_{PP}=12.75V$ may cause permanent damage to the device.
3. The V_{PP} supply voltage is permitted up to 14V for program operation. So the voltage over 14V should not be applied to the V_{PP} terminal. When the switching pulse voltage is applied to the V_{PP} terminal, the overshoot voltage of its pulse should not be exceeded 14V.

TC57H1000AD-85, TC57H1000AD-100 TC57H1001AD-85, TC57H1001AD-100

ERASURE CHARACTERISTICS

The TC57H1000AD / TC57H1001AD's erasure is achieved by applying shortwave ultraviolet light which has a wavelength of 2537Å (Angstroms) to the chip through the transparent window.

The integrated dose (ultraviolet light intensity [w/cm²] × exposure time [sec.]) for erasure should be a minimum of 15 [w · sec/cm²].

When the Toshiba sterilizing lamp GL-15 is used and the device is exposed at a distance of 1cm from the lamp surface, the erasure will be achieved within 60 minutes.

And using commercial lamps whose ultraviolet light intensity is a 12000 [μw/cm²] will reduce the exposure time to about 20 minutes. (In this case, the integrated dose is 12000[μw/cm²] × (20 × 60) [sec.] ≈ 15 [w · sec/cm²].)

The TC57H1000AD / TC57H1001AD's erasure begins to occur when exposed to light with wavelength shorter than 4000Å. The sunlight and the fluorescent lamps will include 3000~4000Å wavelength components. Therefore when used under such lighting for extended periods of time, the opaque seals-Toshiba EPROM Protect Seal AC901-are available.

OPERATION INFORMATION

The TC57H1000AD / TC57H1001AD's six operation modes are listed in the following table.

Mode selection can be achieved by applying TTL level signal to all inputs.

PIN		PGM	CE	OE	V _{PP}	V _{CC}	D0~D7	POWER
Read Operation (T _a = 0~70°C)	Read	H	L	L	5V	5V	Data Out	Active
	Output Deselet	*	*	H			High Impedance	
	Standby	*	H	*			High Impedance	
Program Operation (T _a = 25 ± 5°C)	Program	L	L	H	12.75V	6.25V	Data In	Active
	Program Inhibit	*	H	*			High Impedance	
		H	L	H			High Impedance	
	Program Verify	H	L	L			Data Out	

Note : H ; V_{IH}, L : V_{IL}, * : V_{IH} or V_{IL}

TC57H1000AD—85, TC57H1000AD—100 TC57H1001AD—85, TC57H1001AD—100

READ MODE

The TC57H1000AD/TC57H1001AD has three control functions. The chip enable (\overline{CE}) controls the operation power and should be used for device selection. The output enable (\overline{OE}) and the program control (\overline{PGM}) control the output buffers independent of device selection.

Assuming in that $\overline{CE} = \overline{OE} = V_{IL}$ and $\overline{PGM} = V_{IH}$, the output data is valid at the output after address access time from stabilizing of all addresses. The CE to output valid (t_{CE}) is equal to the address access time (t_{ACC}).

Assuming that $\overline{CE} = V_{IL}$, $\overline{PGM} = V_{IH}$ and all addresses are valid, the output data is valid at the outputs after t_{OE} from the falling edge of \overline{OE} . And assuming that $\overline{CE} = \overline{OE} = V_{IL}$ and all addresses are valid, the output data is valid at the outputs after t_{PGM} from the rising edge of \overline{PGM} .

OUTPUT DESELECT MODE

Assuming that $\overline{CE} = V_{IH}$ or $\overline{OE} = V_{IH}$, the outputs will be in a high impedance state. So two or more ROMs can be connected together on a common bus line. When \overline{CE} is decoded for device selection, all deselected devices are in low power standby mode.

STANDBY MODE

The TC57H1000AD/TC57H1001AD has a low power standby mode controlled by the \overline{CE} signal. By applying a high level to the \overline{CE} input, the TC57H1000AD/TC57H1001AD is placed in the standby mode which reduce the operating current to 100 μ A by applying MOS-high level (V_{CC}) and then the outputs are in a high impedance state, independent of the \overline{OE} inputs.

PROGRAM MODE

Initially, when received by customers, all bits of the TC57H1000AD/TC57H1001AD is in the "1" state which is erased state. Therefore the program operation is to introduce "0's" data into the desired bit locations by electrically programming. The levels required for all inputs are TTL.

The TC57H1000AD/TC57H1001AD can be programmed any location at anytime either individually, sequentially, or at random.

PROGRAM VERIFY MODE

The verify mode is to check that desired data is correctly programmed on the programmed bits. The verify is accomplished with \overline{OE} and \overline{CE} at V_{IL} and \overline{PGM} at V_{IH} .

PROGRAM INHIBIT MODE

Under the condition that the program voltage (+12.75V) is applied to V_{PP} terminal, a high level \overline{CE} or \overline{PGM} input inhibits the TC57H1000AD/TC57H1001AD from being programmed.

Programming of two or more EPROM's in inputs except for \overline{CE} or \overline{PGM} may be commonly connected, and a TTL low level program pulse is applied to the \overline{CE} and \overline{PGM} of the desired device only and TTL high level signal is applied to the other devices.

HIGH SPEED PROGRAM MODE

The device is set up in the high speed programming mode when the programming voltage (+12.75V) is applied to the V_{PP} terminal with $V_{CC}=6.25V$ and $\overline{PGM}=V_{IH}$.

The programming is achieved by applying a single TTL low level 0.1ms pulse the \overline{PGM} input after addresses and data are stable. Then the programmed data is verified by using Program Verify Mode. If the programmed data is not correct, another program pulse of 0.1ms is applied and then programmed data is verified. This should be repeated until the program operates correctly (max. 25 times).

When programming has been completed, the data in all addresses should be verified with $V_{CC}=V_{PP}=5V$.

TC57H1000AD-85, TC57H1000AD-100
TC57H1001AD-85, TC57H1001AD-100

HIGH SPEED PROGRAM MODE

FLOW CHART

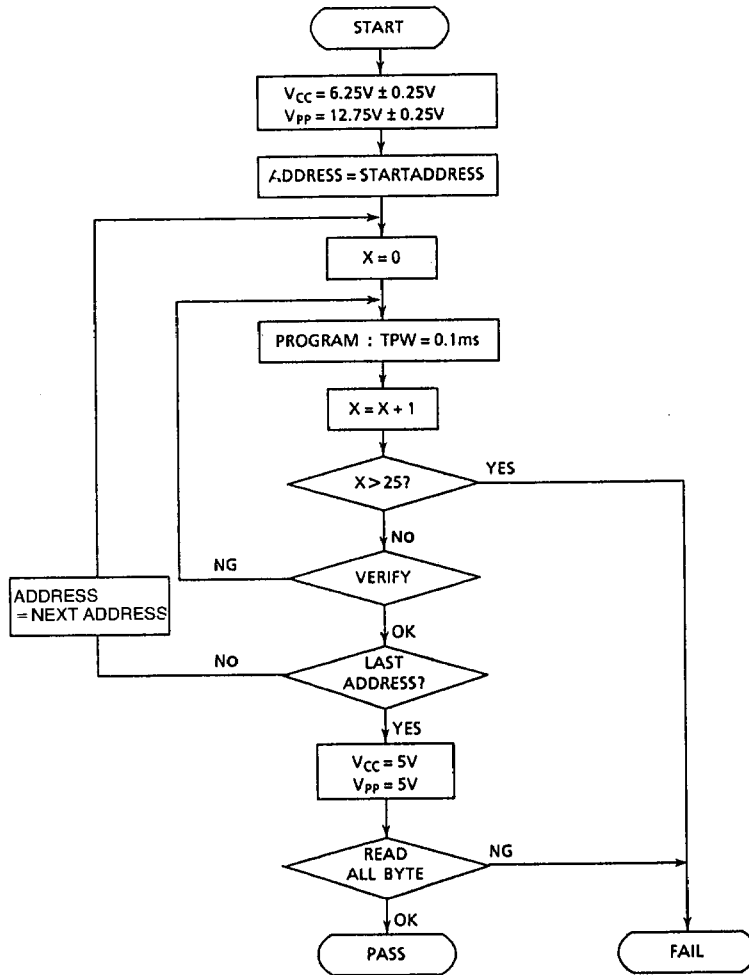

ELECTRIC SIGNATURE MODE

Electric signature mode allows to read out a code from TC57H1000AD/TC57H1001AD which identifies its manufacturer and device type.

The programming equipment may reads out manufacturer code and device code from TC57H1000AD/TC57H1001AD by using this mode before program operation and automatically set program voltage (V_{PP}) and algorithm.

Electric Signature mode is set up when 12V is applied to address line A9 and the rest of address lines is set to V_{IL} in read operation. Data output in this conditions is manufacturer code. Device code is identified when address A0 is set to V_{IH} .

These two codes possess an odd parity with the parity bit of MSB (D7).

The following table shows electric signature of TC57H1000AD/TC57H1001AD.

SIGNATURE		PINS									HEX Data
		A0	D7	D6	D5	D4	D3	D2	D1	D0	
Manufacture Code		V_{IL}	1	0	0	1	1	0	0	0	98
Device Code	TC57H1000AD	V_{IH}	1	0	0	0	0	1	1	0	86
	TC57H1001AD		0	0	0	0	0	1	1	1	07

Notes: A9 = 12V ± 0.5V

A1~A8, A0~A16, CE, OE = V_{IL}

PGM = V_{IH}

TC57H1000AD-85, TC57H1000AD-100
TC57H1001AD-85, TC57H1001AD-100

OUTLINE DRAWINGS

- Cerdip DIP

WDIP32-G-600

Unit : mm

